

Original Research Article

Performance evaluation of Inverted umbrella type rainwater harvesting system at Raichur campus

Abstract

The Inverted Umbrella-Type Rainwater Harvesting System is an innovative approach to collecting and storing rainwater efficiently. It is designed in the shape of an inverted umbrella, with a lightweight and durable frame that can be installed on rooftops, open fields, and urban landscapes. This unique design was used with a aim to maximizes rainwater collection efficiency, even during light showers, while occupying minimal space. The system's adaptability to various geographic and climatic conditions makes it a versatile solution for addressing water scarcity. It has potential applications in residential, commercial, and industrial settings, contributing to more responsible water resource management. Rainfall data was collected from meteorological station at Raichur and potential for rainwater harvesting was calculated. Developed rainwater harvesting system was made out of Mild Steel material and transparent white polyethylene sheet was used as cladding material.. The Inverted Umbrella-Type Rainwater Harvesting System represents a promising step toward more responsible water resource management. The Inverted Umbrella-Type Rainwater Harvesting System of size 3m*3m was selected in the study to analyze rain water harvesting efficiency with components like canopy, central conveying pipe, storage tank, filtration mechanism etc. Once the rain falls over the canopy it was diverted to a central connecting pipe and then stored in a storage tank. A coefficient of performance for *kharif* season during the year 2022 was developed to estimate the efficiency of the system. Annually 5700 litres of water can be harvested from a single unit of inverted umbrella type rainwater harvesting system. Anticipated and actual water yield during *kharif* season was found as 4627.56 and 4480.5 L respectively with overall efficiency as 97%. Key features of this system include high collection efficiency, a small footprint, environmental sustainability, ease of maintenance, and water quality assurance. It reduces reliance on traditional water sources, helping conserve water and mitigate environmental impacts

Keywords: Rainwater harvesting, Inverted Umbrella, Rainwater collection, Water scarcity, Efficient design

Introduction

The resource water is essential to human survival. It makes up roughly two-thirds of the earth's surface, but only 2.5 percent of it can be used by living things. Surface, ground, and atmospheric water can all be classified as types of water; atmospheric water includes moisture found in clouds which precipitates as snow and rain ^[1]. Rainfall is a type of precipitation where

liquid water descends to the earth's surface ^[2]. Snowmelt and rainwater are commonly recognized as the planet's main sources of drinking water. Due to the high rate of enteric and water-borne disease transmission, inadequate and unsafe water supplies, as well as poor sanitation and hygiene practices, are linked to increased morbidity and mortality ^[3]. Millions of people worldwide lack access to clean drinking water for home use, and in many developing nations, conventional piped water is nonexistent, unstable, or prohibitively expensive.

In 2004, the World Health Organization (WHO) ^[4] and the United Nations International Children Education Fund (UNICEF) ^[5] estimated that 80% of all illness in developing countries was linked to water and sanitation ^[6]. It was recently estimated that about 1.1 billion people globally did not have access to improved water supply sources whereas 2.4 billion people did not have access to any type of improved sanitation facility ^[7].

Only 2.5 percent of the world is covered in freshwater, despite the fact that nearly 70 percent of it is. The remainder is marine and saltwater based. Even so, only 1% of our fresh water is readily available, with the majority of it being frozen in snowfields and glaciers. Earth's freshwater reserves remain unchanged, but due to population growth, the world's water supplies are facing an urgent crisis ^[8]. Our lives now revolve around the reality of a water scarcity in both urban and rural areas. Even though the design of rain has changed due to environmental changes, sporadic rain does produce enough water for human use. However, the great majority of it is being wasted because there are no water storage facilities ^[9].

The relationship between water scarcity and population is complex and interdependent. A growing population increases the demand for clean water, which can lead to competition for limited resources, over-extraction, pollution, and ecosystem disruptions. Addressing these challenges involves sustainable water management, conservation, efficient use, infrastructure development. Also, uncertainty in market for agricultural produce is demanding an Integrated Farming Systems (IFS) (integration of agriculture and allied business like aquaculture, dairy, poultry *etc.*) which assures additional income to the farmers. The hydraulic and hydrologic design of inverted umbrella rainwater harvesting (RWH) systems is crucial for their effectiveness and sustainability. Inverted umbrella RWH systems are designed to capture and store rainwater underground, typically beneath impermeable surfaces such as roads and parking lots.

Therefore the study was taken up as a step to conserve this precious natural resource called water.

MATERIALS AND METHODS

Inverted Umbrella Rain water Harvesting System:

The Inverted Umbrella Rainwater Harvesting System is a unique method for managing urban water resources. It uses a subterranean structure that resembles an umbrella to collect rainwater effectively beneath impermeable surfaces. A storage chamber, overflow and drainage mechanisms, a collection and conveyance system, inlets for water entry, filtration and treatment for water quality, and optional features like pumps and monitoring systems are among the essential parts. By collecting, holding, and encouraging the wise use of rainfall in cities, this creative system tackles three issues: sustainability, stormwater management, and water scarcity.

The major components of inverted umbrella rainwater harvesting (RWH) system typically include:

1. **Umbrella Structure:** This is the most distinctive feature of the system. It is usually a curved or dome-shaped structure made of concrete or other suitable materials. The umbrella is installed beneath an impermeable surface such as a road, parking lot, or plaza.
2. **Inlets:** These are openings or collection points strategically placed on the umbrella surface to allow rainwater to flow into the system. Inlets can be designed to capture rainwater efficiently and distribute it to the storage area.
3. **Collection and Conveyance System:** This component consists of pipes, gutters, and other conveyance mechanisms that connect the inlets to the storage area. It ensures that rainwater is transported from the collection points to the storage chamber.
4. **Filtration and Treatment:** To improve water quality, many RWH systems include filtration and treatment components. These may include screens, sedimentation chambers, and water treatment systems to remove debris and contaminants from the harvested rainwater.

5. Storage Chamber: Rainwater is stored underground in a storage chamber, typically constructed of concrete, plastic, or other durable materials. The size of the chamber is determined by the required storage capacity and intended usage of the harvested water.

These components work together to capture, store, and manage rainwater efficiently while ensuring water quality and system functionality in inverted umbrella rainwater harvesting systems. The specific design and components may vary depending on the system's size, purpose, and local conditions.

Annual rainwater harvesting potential

The estimation of annual rainwater harvesting potential involves factors such as the catchment area, catchment efficiency, and the local climate, specifically the annual or monthly rainfall patterns. It provides valuable information for planning and designing rainwater harvesting systems, determining the capacity of storage tanks, and assessing the potential benefits of using harvested rainwater for various purposes, such as irrigation, non-potable water supply, or groundwater recharge.

Annual rainwater harvesting potential is calculated using the equation ^[10]

$$V=K \times I_a \times A \quad \dots (1)$$

Where,

V=Volume of water that can be harvested annually (m³).

K = Runoff coefficient

I_a = Avg. annual rainfall (m)

A = Catchment area (m²)

Water storage tank size calculations for inverted umbrella

Based on the annual rainwater harvesting potential obtained from the above calculations capacity of storage tank is decided. After deciding the storage capacity, number of fillings needed to fulfill the storage capacity is decided .

$$\text{Actual storage capacity of tank needed} = \frac{X}{Y} \quad \dots (2)$$

Where,

X= Storage capacity of tank (m³)

Y = Number of fillings required

Based on the capacity of storage tank, depth of the tank is assumed and on that depth of the tank; area of storage tank is calculated. After calculating area of storage tank, taking length as 2 times of (B), L=2B width and length of tank is calculated (Harshitha *et al.*, 2020).

Determination of co-efficient of performance

A co-efficient of error was developed using rainfall and volume of rainwater collected which even suggest the efficiency of the developed structure. Co-efficient of error is calculated using the following equation^[11]

$$C_e = \frac{v_a}{v_T} \dots\dots(3)$$

Where,

C_e = Co-efficient of error

v_a = Volume of water actually collected in the storage tank

v_T = Volume of water to be collected is predicted theoretically (Rainfall × Area of the structure)

The efficiency is mainly depends on to the run-off coefficient and first flush wastage^[12] Each rainfall event occurred during the study period was recorded and amount of rainwater collected after each event was also recorded and tabulated.

Results and discussion:

Inverted umbrella of 3m×3m was designed and developed with an aim of harvesting high quality rainwater to be used for various purposes like irrigation, domestic, industrial etc.

Historical rainfall data was collected from meteorological station at Raichur and rainfall analysis was carried out prior to designing an Inverted Umbrella Rainwater Harvesting System (Table 1). The overall efficiency of the system in water collection was found as 97% (Table 2).

1. Annual rainwater harvesting potential

$$V=K \times I \times A$$

Where,

V=Volume of water that can be harvested annually (m^3)

K = Runoff coefficient or harvesting efficiency (Assuming it as 100 %)

I_a = Avg. Annual rainfall (m) from Table 1

A = Catchment area (m^2)

$$V=K \times I_a \times A = 1 \times 0.636 \times 9 = 5.73 \text{ m}^3$$

2. Water storage tank size calculations for inverted umbrella

Since average rainwater harvesting potential of the study area is found as 5.73 m^3 which is around 6 m^3 for safety purpose the storage tank is designed for 8 m^3 . Number of fillings taken is 4 and volume of storage tank obtained was 2 m^3

Dimensional details of developed inverted umbrella system is given in Fig 1:

Recent decade rainfall data was collected and analyzed. Average annual rainfall of recent decade (2012-2021) was obtained as 636.53 mm.

Annual Water Harvesting Potential of the study area was obtained as 5.73 m^3 which suggests that annually by using the harvesting umbrella one can harvest upto 5730 Litres of water from a single unit.

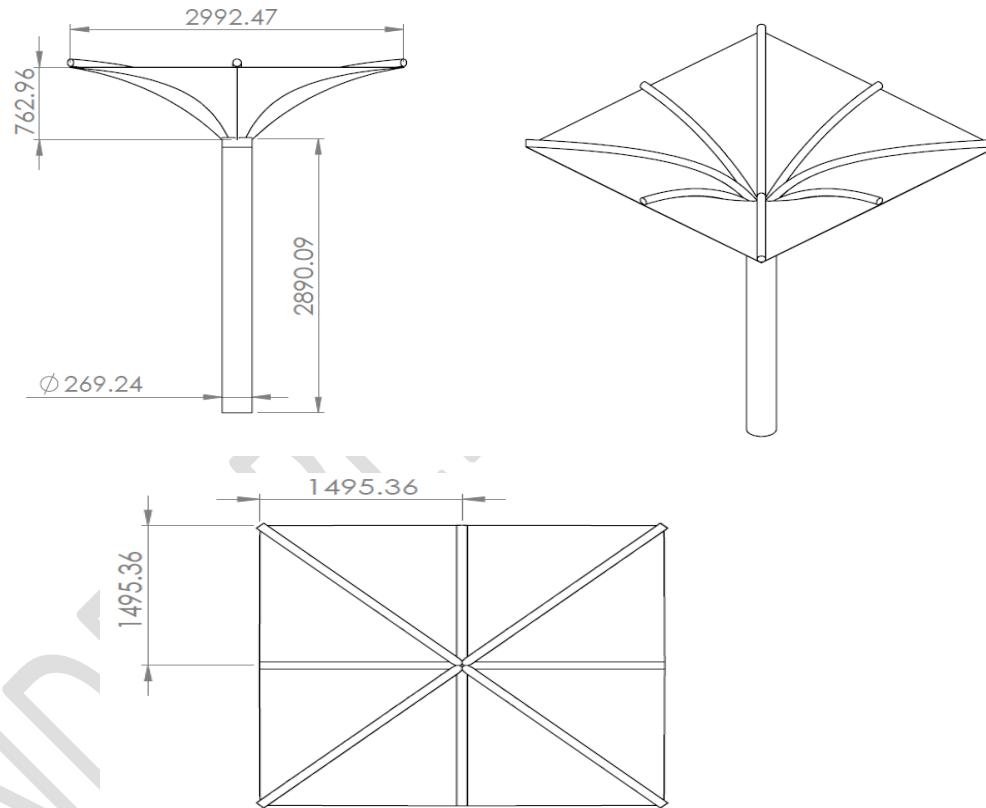

Fig. 1: Dimensional details of Inverted Umbrella Type Rainwater Harvesting System.

Table 1. Month and year wise variation of umbrella rainwater harvesting system

Months	2012	2013	2014	2015	2016	2017	2018	2019	2020	2021	Mean
January	0	0	0	0	2.5	0	0	9.2	0	1.4	3.8
February	0	12.5	0	0	0	0	0	0	0	0.2	1.06
March	0	0	59.0	0	0	0	0	0	0.2	0	5.18
April	39.0	42.5	32.0	38.5	0	10.4	0	28.2	30.8	13.0	22.83
May	1.0	66.5	71.0	51.0	22.0	14.0	0	7.8	126.2	82.2	48.02
June	32.0	81.5	43.5	47.0	178.5	199.0	13.8	61.4	128.4	125.6	94.14
July	133.0	114.5	84.5	28.0	124.0	0	38.8	66.0	248.2	128.0	101.58
August	37.0	50.0	303.0	71.0	82.5	207.8	68.6	82.2	170.8	73.2	113.47
September	42.0	219.0	98.0	109.5	182.5	388.0	126.2	210.8	298.0	130.0	161.63
October	0	55.5	60.0	58.5	25.0	136.6	24.6	131.4	105.6	99.0	65.48
November	0	1	16.0	26.0	0	0	0	0.4	14.4	5.0	8.23
December	0	0	4.0	2.0	12.0	0.2	0	1	0	0.2	1.62
Total	284.0	643.0	771.0	431.5	629.0	956.0	272.0	598.4	1122.6	657.8	636.53

Table 2. Co-efficient of performance for *khariif* season during the year 2022.

Sl. No.	Month	Total rainfall (mm)	Anticipated rainwater yield (litres)	Water Actually collected (litres)	Co-efficient of Performance
1	June	16.00	144.00	137.00	0.95
2	July	104.00	936.00	916.00	0.98
3	August	262.40	2361.60	2304.50	0.97
4	September	131.84	1186.56	1123.00	0.95
Total		514.24	4627.56	4480.5	0.97

Conclusion

The hydraulic and hydrologic design of inverted umbrella rainwater harvesting (RWH) systems plays a pivotal role in their effectiveness and sustainability. It optimizes water collection efficiency by considering factors like the size and slope of the umbrella and the positioning of inlets to channel rainwater effectively into storage. Additionally, it addresses water quality concerns through filtration and treatment processes, making the harvested water suitable for various uses. The design determines the storage capacity based on local climate and intended use, ensuring the system can capture and store sufficient water. **Annually 5700 litres of water can be harvested from a single unit of inverted umbrella type rainwater harvesting system. Average anticipated water yield for a rainfall of 514.24 mm during *Kharif* season of the year 2022 was obtained as 4627.56L with actual water collection of 4480.50 L. The overall efficiency of entire system was obtained as 97%.**

Compliance with local regulations is essential, and data collection mechanisms may be included for monitoring and making necessary adjustments. In summary, hydraulic and hydrologic design is vital to the success of inverted umbrella RWH systems, ensuring their efficiency, durability, and compliance with regulatory standards.

The Inverted Umbrella Rainwater Harvesting System offers an innovative solution to address urban water scarcity and stormwater management. It efficiently captures and stores

rainwater, contributing to water conservation, flood prevention, and sustainable water resource management in urban areas.

References

- [1] Shittu, O.I., Okareh, O.T. and Coker, A. O. 2012, Design and construction of rainwater harvesting system for domestic water supply in Ibadan, Nigeria. *Journal of Research in Environmental Science and Toxicology*, 4 (6): 153-160.
- [2] White, K.H., Soward, L.R. and Shankle, G. 2007. Harvesting, Storing, and Treating Rainwater for Domestic Indoor Use, Texas Commission on Environmental Quality, Austin, Tex, USA.
- [3] Chabalala, P. and Mamo, H. 2001. Prevalence of water-borne diseases within the health Facilities in Nakuru district, Kenya. Kenya: University of Nairobi.
- [4] WHO. 2004. The sanitation challenge: turning commitment into reality. World Health Organization, Geneva, Switzerland. Available at: https://www.researchgate.net/publication/253651498_The_Sanitation_Challenge. Accessed on 20/07/2017.
- [5] WHO and UNICEF. 2010. Global Water Supply and Sanitation Assessment 2010 Report, WHO, Geneva. From http://who.int/water_sanitation_health/monitoring
- [6] Cudjoe, F. and Okonski, K. 2006. The Reality of Water Provision in Urban Africa. *The Water Revolution*: 176 – 200.
- [7] Hamed, T. B., Sridhar, M. C. and Fawole, O. B., 2017, A low cost ‘umbrella rainwater harvester’ for open air markets in Nigeria: Design, fabrication, yield and quality assessment. *Int. J. Scientific Engg. Res.* 8(7):1451-1458.
- [8] Keskar, A., Taji, S., Ambhore, R., Potdar, S., Ikhar, P. and Regulwar, D. G., 2016, Rain water harvesting—a campus study. Paper presented In: *3rd National Conference on Sustainable Water Resources Development and Management (SWARDAM–2016)*, Aurangabad, p.133.
- [9] Harshitha, G., Gagana, G. M., Shivaraj, K. R. and Yathish, G. R., 2020, Umbrella design for rain water harvesting and harnessing solar energy at cit college campus gubbi. *Int. Res. J. Modernization in Engg Tech. Sci.* 2(6): 743-749.
- [10] Villar-Navascués, R., Pérez-Morales, A. and Gil-Guirado, S., 2020, Assessment of rainwater harvesting potential from roof catchments through clustering analysis. *Water*, 12(9):2623-2628.

- [11] Pooja, N.V., Nagarajappa, D.P., Pruthviraj, S.R. and Shivakeshavakumar, P., 2022, Water conservation strategy and its enhancement technique in recharging rain water along with its utilization for University BDT College of Engineering, Davanagere. *Int. J. of Advances in Engg and Manag.*4(10): 759-765.
- [12] Al Mamun, M. A., 2020, Study on rainwater harvesting and determination of its quality for drinking purpose. *Bachelors Thesis*, World University of Bangladesh.

UNDER PEER REVIEW