

# Thermal study of the utilization of rice husks using the forced convection method as energy for a rotating cylinder dryer

## ABSTRACT

Small farmers in rural areas use the sun as their main energy source to dry post-harvest products. Due to limited knowledge and technology, farmers depend on the sun through direct drying. Direct use of the sun for the drying process has disadvantages in uncertain weather such as cloudy or rainy. This results in the drying process not being optimal or even stopping. This research aims to use rice husks as energy to replace direct sun drying to produce optimal temperatures so that drying time is shorter and the quality of the dried food is hygienic. Rice husk as an energy source is applied through a rotating cylinder dryer. This dryer is tailored to farmers' needs, namely easy to operate at an affordable price. This energy can be utilized sustainably because it is abundant through a forced convection system and energy conversion using a heat exchanger. The design of the compact rotary dryer includes an integrated drying chamber in one unit with the combustion furnace and a heat exchanger. The drying chamber includes a rotating cylinder and a fixed cylinder. The test results show that hot air from burning rice husks flows through the heat exchange pipes by conduction from the furnace to the walls of the drying chamber and by forced convection through an exhaust fan installed in the drying chamber. The average environmental temperature of 29.55-29.69°C has increased when using one exhaust fan to 64.46°C and two exhaust fans to 60.11°C. This drying temperature can produce shorter drying times, so it can be applied to post-harvest product drying, which is energy-efficient and sustainable for small farmers. Based on research results, rotating cylinder dryers powered by rice husks are very suitable for small farmers to replace direct sun drying.

*Keywords: Rotating cylinders; forced convection; heat exchangers; rice husks; small farmers*

## 1. INTRODUCTION

Rice husks as waste from agriculture have quite good potential to be used as a substitute for solar and fossil energy. Utilizing rice husks as an energy source can save post-harvest costs, especially in the drying process. The drying process involves energy conversion using a heat exchanger. Especially for drying grain, it is more effective to use a rotating cylinder dryer known as the rotary type.

Rotary dryers are in the form of drums that rotate and obtain heat from an energy source in the form of electricity, sun, or biomass. In this case, the energy source used is rice husk biomass. Utilization of rice husk biomass in rotary dryers because this waste is easy to obtain and cheap. Energy needs through the use of biomass can reduce the use of firewood and improve the economic status of rural communities in developing countries [1, 2]. Rice husks, as a by-product of rice production, have the potential to be used as an energy source and are available in abundant quantities. Specifically in Lombok and West Nusa Tenggara, based on 2020 data, the amount of rice husks was 269,420.20 tons and 533,150.80 tons respectively [3]. Apart from that, the calorific value of rice husks is equivalent to half the calorific value of coal, namely 11-15.3 MJ/kg; suitable for heat energy use because it contains silica, lignin, and cellulose and has a maximum temperature of 560°C and 556.5°C respectively through tests carried out on direct combustion and using a stove [4, 5, 6, 7]. Using rice husks as an energy source for drying through an energy conversion process with

a heat exchanger can produce a shorter drying time than sun drying [8]. Small farmers who carry out the process of drying grains such as corn, coffee, and grain also need a tool so that when working, they are not exposed to sunlight and do not require a product-turning process. This can be achieved by using a drying device that can rotate, namely a rotary dryer.

The application of rotary dryers for grain foods provides uniform drying results, affordable costs, and easy operation. Maintenance of rotary dryers requires low prices, and the specific energy consumed is less, namely 15 to 30% [9]. Rotary dryers in the form of cylinders or drums that rotate continuously with energy from biomass are very suitable for use by small farmers. Mixing, cooling, heating, and drying processes for granular materials widely use rotary drums [10, 11, 12]. Rotary dryers with rice husk energy sources are carried out using the energy conversion method using a heat exchanger. The application of a heat exchanger for the heat transfer process is due to temperature differences from burning rice husks to the environmental air flowing in the heat exchanger pipes. The temperature difference between two fluids separated by a wall produces a heat transfer process using a heat exchanger [13]. A heat exchanger from a parallel tube arrangement can optimize heat transfer from burning rice husks to the environmental air used for the drying process [14, 15]. Utilization of a heat exchanger to optimize heat transfer to the drying chamber so that the drying temperature is maximized. The research was carried out with a forced convection system using an exhaust fan to determine the temperature conditions that the rotary dryer can produce. In addition, rotary dryers that suit needs and are designed based on worker participation as users to replace direct sun drying can lighten the physical burden when working. A participatory approach is the most effective way to build manual tasks and lighten the physical workload [16, 17].

## 2. MATERIAL AND METHODS

The research was carried out by testing the results of a rotary dryer design with a forced convection system using two variations of exhaust fans placed in the drying room. The rotary dryer in this study was designed to be compact, namely, the drying chamber is in one unit with the combustion furnace. The combustion furnace is equipped with air circulation holes in the walls, ash reservoir, and heat exchanger pipes. The drying chamber consists of two cylinders, including the outer part, which is a fixed cylinder in the form of a noncircular cylinder that is attached to the combustion furnace and connected to heat exchange pipes. Meanwhile, the rotary cylinder is located inside the fixed cylinder as a place to dry food ingredients. The drying process takes place by following the rotation of the cylinder to produce a product with a more even temperature. This cylinder can rotate and is driven by a motor with a gear transmission. The dryer design is tailored to the needs of small farmers. The materials and tools used include rice husks, iron plates, iron boxes, stainless steel plates, stainless steel pipes, iron shafts, 1 HP dynamos, gearboxes, insulating rubber, trolley wheels, transmission systems, drying cylinders, exhaust fans, type K thermocouples, rotary cylinder, and data logger. The rotary cylinder has dimensions, namely an inner diameter of 400 mm and a length of 800 mm. Furnace with a rice husk capacity of 18 kg with dimensions of 800 mm x 400 mm x 500 mm. The size and diameter of the heat exchanger pipes are 450 mm and 1 inch. The test uses a dryer design, as in Figure 1, with the test method shown in Figure 2.

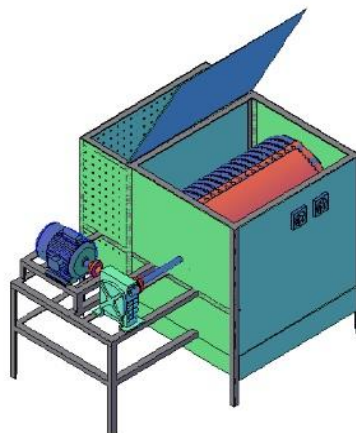

**Fig. 1. Compact rotating cylinder dryer design with rice husk energy**

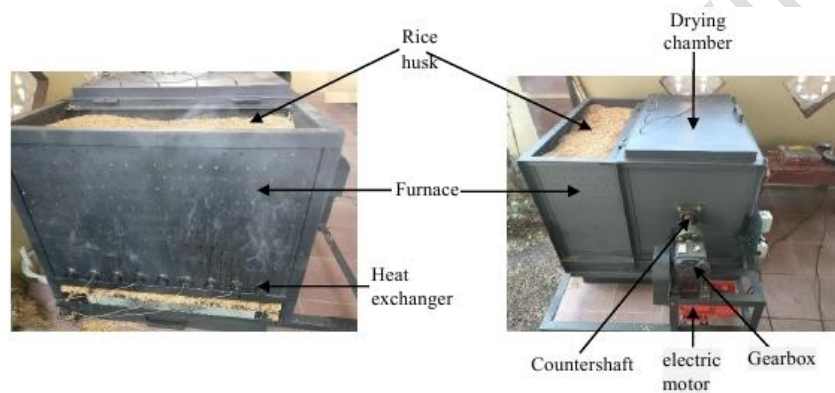
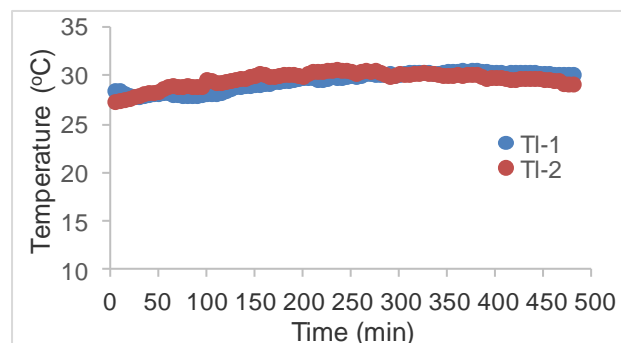

**Fig. 2. Testing of a compact rotating cylinder-type dryer using rice husk energy**

The research was conducted to evaluate the performance of a rotary dryer powered by rice husk using a forced convection system by comparing the use of one and two exhaust fans. The rotary dryer test was carried out to treat a constant amount of rice husk, namely 18 kg, and there was no addition of rice husk mass during the trial. Evaluation based on environmental temperature, heat exchanger pipe temperature, drying room temperature, and drying time.

### 3. RESULTS AND DISCUSSION

Forced convection system rotary dryers are measured based on tests carried out on the utilization of one and two exhaust fans. Measurements are based on drying room conditions without load and include environmental temperature, heat exchanger pipe, drying room, and drying room exit temperature. In testing, it was found that the drying time for the rice husk mass was constant, namely 480 minutes. Tests were carried out on one and two exhaust fans, respectively. For one and two exhaust fans, the environmental temperature does not affect the thermal test of the rotary dryer. Thermal conditions were measured when the rice husk ignition time had been running for 5 minutes. Comparison of environmental temperatures between one and two exhaust fans for a test time of 480 minutes, as shown in Figure 3.



**Fig. 3. Comparison of environmental temperatures of one exhaust fan (TI-1) and two exhaust fans (TI-2) for 480 minutes**

The environmental temperature during the 480-minute test time for the use of one and two exhaust fans each had an average of 29.55°C with a range of 27.88-30.59°C and 29.69°C with a range of 27.37-30.69°C. This environmental temperature is less than optimal if used directly in a food drying process. Based on tests on rotary dryers using rice husk as an energy source, it was found that the environmental temperature (TI) had increased and could be seen in the exit temperature of the heat exchanger pipes, as shown in Figure 4.

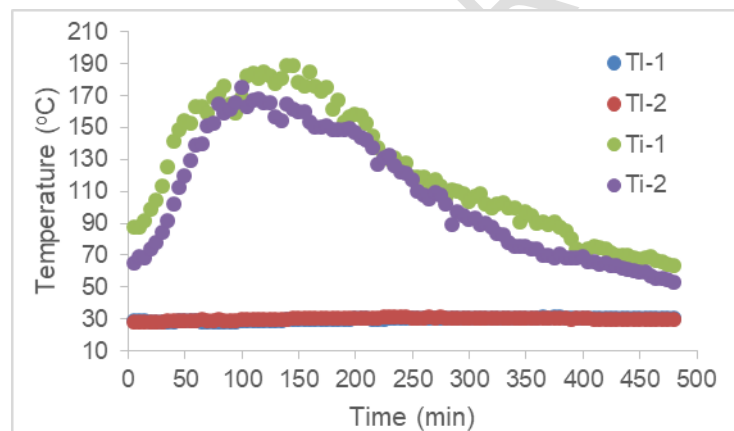

**Fig. 4. Comparison of the exit temperature of the heat exchanger pipes of one exhaust fan (Ti-1) and two exhaust fans (Ti-2) for 480 minutes**

The increase in environmental temperature (TI) measured at the exit temperature of the heat exchanger pipes when using one and two exhaust fans is 312.63% - 262.83%, respectively. The average exit temperature of the heat exchanger pipes when using one exhaust fan (Ti-1) is 122.24°C with a range of 63.28-125.22°C. Meanwhile, for two exhaust fans (Ti-2), it is 107.48°C with a range of 52.61-122°C. This exit temperature is the temperature entering the rotary drying chamber. From the measurement results, it was found that the average temperature in the rotary drying chamber was 64.46°C and 60.11°C when using one and two exhaust fans, respectively. This is shown in Figure 5.

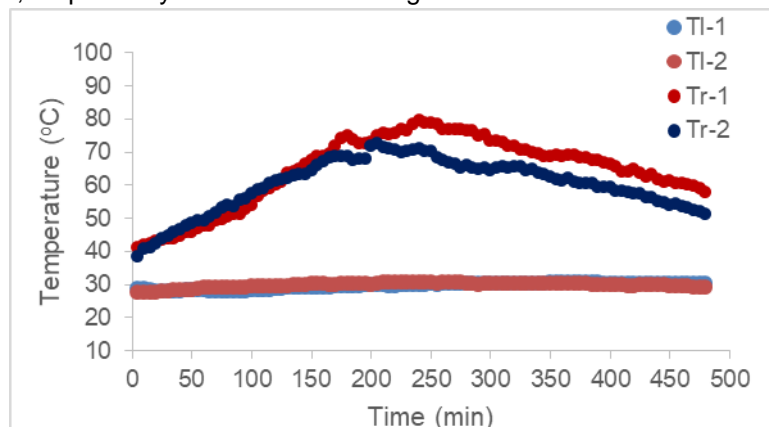

**Fig. 5. Comparison of drying chamber temperatures for one exhaust fan (Tr-1) and two exhaust fans (Tr-2) for 480 minutes**

The temperature of the drying chamber follows the temperature pattern at the exit of the heat exchanger pipes. This temperature pattern follows the process of burning rice husks in a furnace due to the absence of an additional mass of rice husks. At the beginning of the rice husk burning process, there is a temperature pattern that has not yet increased. This is because the rice husks undergo a process of evaporation of water content at the beginning of the combustion process. Rice husks have a water content of 6-10% [18, 19]. In general, biomass, before undergoing further heating, begins with a process of evaporation of water content, which is called the drying zone [20]. This can be seen from the burning smoke, which is still high. The temperature has a pattern; namely, at the start of combustion, it rises until it reaches the maximum temperature, then decreases as the mass of rice husks in the furnace decreases.

The application of a rotary dryer with rice husks as an energy source in a combustion furnace with heat exchange pipes for the energy conversion process is capable of producing a fairly high increase in environmental temperature. Rice husks are suitable for heat energy use because they mostly contain cellulose, lignin, and silica [21]. Lignin presents a greater combustion enthalpy, which facilitates its application in combustion processes [22]. Likewise, the choice of heat exchanger with fixed tubes is to facilitate wider utilization and traditionally minimize total annual costs [23]. Based on the temperature characteristics, the results of this research can be continued for testing on food ingredients that comply with the permitted temperature standards. Apart from that, the dryer model is suitable for small farmers in rural areas with an affordable price and is easy to operate. The use of rice husks has an impact on the process of maintaining a sustainable environment starting from a small area. This is related to how to process energy waste and reduce forest logging.

#### **4. CONCLUSION**

Furnaces are used for direct combustion of rice husks, heat exchange pipes for indirect methods, and exhaust fans for forced convection systems. The results show that the thermal conditions of the rotary dryer based on the temperature of the drying room using ambient air can be improved optimally. The heat from the rice husks is transferred to the ambient air flowing in the heat exchanger pipes. The hot air is channeled into a non-circular fixed cylinder and used to heat the rotating cylindrical drying chamber. Heat transfer by conduction through the furnace walls and drying chamber. The heat produced is capable of producing a constant high temperature. For an environmental air temperature with an average of 29.55-29.69°C, it can have an average drying room temperature for one and two

exhaust fans of 64.46°C and 60.11°C, respectively. Results like this can be used as an alternative for developing post-harvest dryers for small farmers that are energy efficient and sustainable.

## REFERENCES

1. UI Haq MA, Nawaz MA, Akram F, Natarajan VK. Theoretical implications of renewable energy using improved cooking stoves for rural households. *International Journal of Energy Economics and Policy*. 2020; 10(5): 546-554.
2. Ahiduzzaman M, Sadrul Islam AKM. Assessment of rice husk briquette fuel use as an alternative source of woodfuel. *International Journal of Renewable Energy Research*. 2016; 6(4): 1601-1611.
3. RUED Provinsi Nusa Tenggara Barat. Potensi Limbah Perkebunan untuk Biomassa. Peraturan Daerah Provinsi Nusa Tenggara Barat. 2019; 3.
4. Yan S, Yin D, He F, Cai J, Schliermann T, Behrendt F. Characteristics of smoldering on moist rice husk for silica production. *Sustainability*. 2022; 14(1): 317.
5. Awulu JO, Omale PA, Ameh JA. Comparative analysis of calorific values of selected agricultural wastes. *Nigerian Journal of Technology (NIJOTECH)*. 2018; 37(4): 1141-1146.
6. Thiedeitz M, Schmidt W, Härder M, Kränkel T. Performance of rice husk as has supplementary cementitious material after production in the field and in the lab. *Materials*. 2020; 13(19): 1-17.
7. Tangka JK, Ngah JK, Tidze VC, Sako ET. A rice husk fired biomass stove for cooking, water and space heating. *International Journal of Trend in Research and Development*. 2018; 5(6): 83-89.
8. Alit IB, Bawa Susana IG, Mara IM. Thermal characteristics of the dryer with rice husk double furnace-heat exchanger for smallholder scale drying. *Case Studies in Thermal Engineering*. 2021; 28: 101565.
9. Giudice AD, Acampora A, Santangelo E, Pari L, Bergonzoli S, Guerriero E, Petracchini F, Torre M, Paolini V, Gallucci F. Wood chip drying through the using of a mobile rotary dryer. *Energies*. 2019; 12(9): 1590.
10. Ettahi K, Chaanaoui M, Sébastien V, Abderafi S, Bounahmidi T. Modeling and design of a solar rotary dryer bench test for phosphate sludge. *Hindawi Modelling and Simulation in Engineering*. 2022; 5574242.
11. Xie Q, Chen Z, Mao Y, Chen G, Shen W. Case studies of heat conduction in rotary drums with L-shaped lifters via DEM. *Case Studies in Thermal Engineering*. 2018; 11: 145-152.
12. Trojosky M. Rotary drums for efficient drying and cooling. *Drying Technology*. 2019; 37(5): 632-651.
13. Bergman TL, Lavine AS, Incropera FP, Dewitt DP. *Fundamentals of Heat and Mass Transfer*. 7<sup>th</sup>. 2011. John Wiley & Sons.
14. Bawa Susana IG, Alit IB, Mara IM. Optimization of Corn Drying with Rice Husk Biomass Energy Conversion Through Heat Exchange Drying Devices. *International Journal of Mechanical and Production Engineering Research and Development (IJMPERD)*. 2019; 9(5): 1023-1032.
15. Alit IB, Bawa Susana IG. Drying performance of jackfruit dodol using rice husk energy on household in Lombok, Indonesia. *Frontiers in Heat and Mass Transfer*. 2021; 17: 15.
16. Burgess-Limerick R. Participatory ergonomics: Evidence and implementation lessons. *Applied Ergonomics*. 2018; 68: 289-293.
17. Sormunen E, Mäenpää- Moilanen E, Ylisassi H, Turunen J, Remes J, Karppinen J, Martimo KP. Participatory ergonomics intervention to prevent work disability among

workers with low back pain: a randomized clinical trial in workplace setting. *Journal of Occupational Rehabilitation*. (2022).

18. Kamari S, Ghorbani F. Extraction of highly pure silica from rice husk as an agricultural by-product and its application in the production of magnetic mesoporous silica MCM-41. *Biomass Conversion and Biorefinery*. 2020; 1-9.
19. Herodian S. Peluang dan tantangan industri berbasis hasil samping pengolahan padi. *Jurnal Pangan*. 2007; 16(1): 38-49.
20. Mufid F, Anis S. Pengaruh jenis dan ukuran biomassa terhadap proses gasifikasi menggunakan downdraft gasifier. *Rekayasa Mesin*. 2019; 10(3): 217-226.
21. Thiedeitz M, Schmidt W, Härder M, Kränkel T. Performance of rice husk as has supplementary cementitious material after production in the field and in the lab. *Materials*. 2020; 13(19): 1-17.
22. Grotto CGL, Colares CJG, Lima DR, Pereira DH, Do Vale AT. Energy potential of biomass from two types of genetically improved rice husks in Brazil: A theoretical-experimental study. *Biomass and Bioenergy*. 2020; 142: 105816.
23. Chen LY, Adi VSK, Laxmidewi R. Shell and tube heat exchanger flexible design strategy for process operability. *Case Studies in Thermal Engineering*. 2022; 37: 102163.

UNDER PEER REVIEW