

## Dissecting the genetic relationship between Root morphological traits with grain yield of **Introgression lines** (ILs) derived from wild rice (*Oryza rufipogon* Griff) under low soil phosphorous condition

**Abstract:** Soil phosphorous (P) deficiency is one of the limiting factors in rice production in both upland and rainfed lowland ecosystems. Since P is diffusion limited in depleted root zones, understanding the link between root morphological traits and yields is crucial for improving rice productivity. To understand this link, phenotypic screening experiment was conducted for the 38 ILs ( $BC_1F_6$ ) derived from the wild rice (*Oryza rufipogon* Griff) along with the six checks in specialized low P plots and normal soil P (RDF) plot at ICAR-IIRR, Hyderabad during rice growing season *Kharif-2020* by adapting augmented block design. The genotypes were screened for grain yield along with root traits such as tiller number per plant (TN), shoot length (SL), root length (RL), root volume (RV), shoot fresh weight (SFW), shoot dry weight (SDW), root fresh weight (RFW), root dry weight (RDW), root to shoot ration on wet weight basis (RSRWW), root to shoot on dry weight basis (RSRDW), SPAD chlorophyll meter reading (SCMR). The results from ANOVA revealed that, MSS due to genotypes, (checks + genotypes) were significant (( $p < 0.01$  and  $p < 0.05$ )) for most of the root architectural traits and for two different regime of P under investigation. Wide range of genetic variation was recorded for the traits such as RL, RV, SFW, SDW, RFW, RDW, RSRWW, RSRDW and GYP with high GCV and PCV and high  $h^2$  coupled with high GAM under both P gradient conditions. Strong inter-correlation among the component traits was observed for the root traits such as RV (0.43\*\* : 0.50\*\*), SFW(0.81\*\* : 0.60\*\*), SDW (0.65\*\* : 0.81\*\*), RFW (0.87\*\* : 0.64\*\*), RDW (0.83\*\* : 0.87\*\*) and RL (0.36\*\* : 0.43\*\*) along with GYP (0.52\*\*) under low soil P and normal soil P. Principal component analysis with first four PCs revealed existence of 69.40 and 70.30% of total variance and clustering analysis identified the promising genotypes as IL-9-10, IL-11-2, IL-21-8, IL-19-3, IL-22-1, IL-23-2, IL-23-7, IL-31-3, IL-42-3, IL-67-2, IL-69-1, IL-75-2, Swarna and Rasi with root traits RV, RDW, RFW, RL, and GYP are effective traits for rice cultivation.

**Keywords:** *Oryza rufipogon* Griff, Root architecture, Low soil phosphorous, Principal component analysis, Correlation matrix

**Introduction:**

“Rice (*Oryza sativa* L.), the staple food plant with the highest demand worldwide, provides daily sustenance to more than half of the global population. The Asian wild rice, *Oryza rufipogon* Griff (2n=24, AA) commonly known as red rice or brown rice, is a wild ancestor for cultivated rice which is used as a valuable germplasm resource in introgression and transferring of novel traits into the commercial bred elite cultivated rice lines due to its richness in genetic diversity” Londo et al., 2006 [21]. “Phosphorus (P) is an essential element for normal cell growth and cell division in all organisms. P is essential to plants and their roots acquire P from the rhizosphere solution as phosphate (Pi), primarily in the form of H<sub>2</sub>PO<sub>4</sub>. Phosphorus deficiency is a common mineral nutritional issue in calcareous and acidic soils, drought-prone areas, high pH soils, due to the formation of poorly soluble P complexes with calcium in alkaline soils and Al and Fe in acidic soils” Tiessen, 2008 [37]. Long back ago Batjes, 1997 [3], estimated that “P availability to plant roots is limited in nearly 67% of the cultivated soils, causing an important constraint to crop production”. “Most of the P applied to soils to meet P demand of plants is converted into unavailable forms of P that cannot be easily used and taken up by plant roots. Development of plant genotypes (e.g., ‘P-efficient’ genotypes) with greater ability to grow and yield under P-deficient soil conditions is, therefore, an important goal in plant breeding” Hash et al., 2002 [16]; Wissuwa et al., 2002 [44]; Yan et al., 2004 [47], Manoj et al., 2023 [27]. “Development of P-efficient genotypes in both high- and low-input production systems would reduce the production costs associated with P fertilizer applications, minimize environmental pollution and contribute to maintenance of world P resources globally” Vance et al., 2003 [38]. Plant species and genotypes develop diverse adaptive responses under P deficiency stress, to overcome the stress conditions by developing two major mechanisms: (i) P acquisition (root morphology, root exudation and P uptake mechanisms) and (ii) P utilization (internal mechanisms associated with better use of absorbed P at cellular level).

“The root system is described as the “hidden half”, because it performs a pivotal function in overall crop development as well as in advancement. The root systems have long been considered to be a vital part of plants, as they supply nutrition. Root characteristics influence the development and improvement of shoot parts via the reformed root-to-shoot distribution of nutrient elements which subsequently regulates shoot development and seed yield. The development and advancement of above ground plant parts are closely related to root morphology and root traits and represents a potential source of genetic variation to improve P

acquisition for breeding such crops” Lynch, 2007 [24], Powlson et al., 2011 [30]; De Smet et al., 2012 [8]; Lynch and Brown, 2012 [22]. “Assessment of root traits in crop breeding material can be slow and expensive, involving a combination of field, glasshouse- and laboratory-based screens” Clark et al., 2011 [6]. “The latter of these is amenable to high-throughput screens to identify germplasm with altered root growth and morphology. Genetic loci associated with these traits have the potential for use in breeding new crop varieties with improved root phenotypes. Increases in the number and length of lateral roots are observed under low Pi availability, density and length of root hairs increased when plants are grown on a low Pi supply, thus increasing the capacity for Pi acquisition. Biochemical adaptations, including the release of organic anions to release Pi bound to clay particles” Brown et al., 2012 [4].

“Currently, P deficiency occurs to about 50% of the agricultural soils in many Asian, African and South America countries” Lynch, 2011 [23]. “Therefore, the balanced and sustainable use of P fertilizer is of paramount importance” Vinod and Heuer 2012 [41], Basavaraj et al., 2021 [2]. P-deficient tolerance, or P-efficient uptake, in rice is a useful trait to improve. Rice usually develops morphological, physiological, biochemical, and molecular adaptations to overcome P deficiency Raghothama and Karthikeyan, 2005 [32], Koyama et al, 1973 [20] reported “the first genotypic difference for P-deficient tolerance in rice. Since then, the development of cultivars with improved P uptake is considered more effective than relying only on strategic fertilizer application. So far, rice breeders have concentrated their efforts on screening the existing cultivars and lines under P-deficient conditions and evaluating the variable traits related to the tolerance. Information on the inheritance of P-deficient tolerance and P-efficient uptake traits is valuable in initiating an effective breeding program in rice”. Chaubey et al.1994 [5] ; Majumder et al.1989 [26] found that “P-deficient tolerance is a quantitatively inherited trait with a mostly additive gene action”. Since the reports of Wissuwa et al. in 1998 [45], ‘Kasalath’ (*O. sativa*)—a **upland** landrace of rice from Karimganj, Assam, India—has been used as a donor parent in consecutive studies on P uptake. “Detection of the phosphorus uptake 1 (*Pup1*) quantitative trait loci (QTL) was discovered to relate to high P-uptake, an increase in tillering ability, and an improvement in root growth under P-deficient upland conditions”, Wissuwa and Ae 2001 [42] and Wissuwa et al., 2002 [44], Shimizu et al., 2004 [34] ; Shimizu et al., 2008 [33]. There are data available on root characteristics and yield in general, but less information on the interaction between root traits and yield under low soil P conditions, such insights are crucial for

determining the root attributes that will facilitate the selection and breeding of high-yielding rice lines. Therefore, this study aimed to screen the introgression lines (ILs) of *Oryza rufipogon* and Samba mahsuri for root morphological characteristics with grain yield under gradient soil P conditions, to assess the extent of genetic variability in P efficiency, to explore the comprehensive links between root and yield attributes through multivariate analysis.

## **Material and methods:**

### **Plant Material:**

In the present study thirty eight BC<sub>1</sub>F<sub>6</sub> introgression lines (ILs) derived from the cross between Samba Mahsuri, a low soil P (P<sub>0</sub>) sensitive cultivar used as recipient parent and *O. rufipogon* used as donor parent, along with low soil P sensitive checks BPT- 5204, Ratnachudi, ISM, Tanu and low P tolerant checks such as Swarna and Rasi and they were evaluated for root traits under both normal soil P and low soil P conditions during *Kharif*-2020. The experiment was carried out at ICAR-IIRR, Hyderabad, India, which is located at an altitude of 542.3 m above mean sea level, 17°19' North and 78°23' East, and positioned in the southern zone of Telangana state, India. The low P plot at ICAR-IIRR was developed by not applying P for a quite long time (>20 years). At present, the available P (that is, Olsen P) in this plot is estimated to be <2 kg/ha. The seeds were sown in a nursery bed and 21-day old seedlings were transplanted to the main field, which is maintained by regular supply of bore well irrigation. The seeds were planted following a spacing of 20 cm × 10 cm in augmented block design, no P fertilizer was applied to the low soil P plot. However, the recommended dose of P fertilizer was applied to a normal soil P plot (P: 60 kg/ha). Other essential nutrients like nitrogen (100 kg/ha) and potash (40 kg/ha) were applied as per recommended agronomic practices to raise a good crop.

### **Determination of root morphological Traits by destructive method:**

At maximum tillering stage three competitive plants were selected and uprooted from the field by destructive method without causing much damage to the roots system, roots were washed with running water to remove soil debris and excess water that remained on the surface of the roots was removed by blotting with absorbent paper. The root attributing traits along with yield such as tiller number per plant (TN), shoot length (SL), root length (RL), root volume (RV), shoot fresh weight (SFW), shoot dry weight (SDW), root fresh weight (RFW), root dry

weight (RDW), root to shoot ration on wet weight basis (RSRWW), root to shoot on dry weight basis (RSRDW) were recorded. In the main field, SPAD chlorophyll meter reading (SCMR) and grain yield per plant (GYP) were recorded.

Root volume was measured by using measuring cylinder as a water displacement method containing known initial volume of water with rise in the final volume and it is expressed in 'mL'. The root and shoot length were measured in 'cm' by using meter scale reading and root and shoot fresh weight along with their dry weight were measured in 'g' by using electronic balance meter. The root and shoot ratio on both wet and dry weight basis were calculated from following formulae.

$$\text{Root to shoot ratio (wet weight basis)} = \frac{\text{Fresh root weight (g)}}{\text{Fresh shoot weight (g)}}$$

$$\text{Root to shoot ratio (dry weight basis)} = \frac{\text{Dry root weight (g)}}{\text{Dry shoot weight (g)}}$$

### **Statistical analysis:**

The mean data for each character was subjected to statistical analysis. The estimates of genotypic and phenotypic coefficient of variation and ANOVA, correlation, principle component analysis (PCA) was carried out by using standard protocol package called (*ggplot*, *agricolae*, *corrplot*,) R software (*version 4.3.2*) R Core Team 2020 [31], cluster analysis were done by UPGMA method using Paleontological Statistics Software (PAST) *version 4.03* Hammer *et al.*, 2001 [15] package for education and data analysis.

### **Results and discussion**

## **ANOVA:** A source of variation

The results of ANOVA from mean sum of squares (MSS) for root architectural traits in 38 ILs along with the checks were given in Table 1. The results revealed that MSS due to entries (ILs + checks) were highly significant ( $p < 0.01$  and  $p < 0.05$ ) for the traits under study, viz., SL (81.28\*\* : 62.18\*\*), RV (3.78\* : 5.68\*\*), SFW (23.6\*\* : 15.50\*\*), RFW (4.82\*\* : 5.24\*), RDW (0.04\* : 0.08\*\*), RSRWW (0.06\* : 0.04\*\*), RSRDW (0.02\*\* : 0.04\*) and GYP (1.76\*\* : 3.18\*) under both low soil P and normal soil P respectively. The size of the observed significant differences suggested that the genotypes under investigation exhibit a greater amount of genetic diversity. The coefficient of variation (CV %) was substantial heterogeneity for root related traits, for instance, the CV were reasonably higher for RSRDW (28.26) under normal soil P and RDW (26.48) under low soil P with the least CV obtained for SL (2.42 : 3.28) under both normal soil P and low soil P respectively. The overall result of ANOVA revealed that, MSS due to genotypes, checks and entries (checks + genotypes) were significant for most of the root architectural traits and for two different regime of P under investigations, as a whole, root length, root volume, shoot dry weight and root dry weight plant had larger significant difference or effect than other traits studied and variability among the genotypes were significant for root architectural traits, especially under low P, so these findings confirm the presence of significant differences for root attributing traits in the experimental material and offers scope for further investigations to the variability studies. Similar finding were reported by da-Silva et al. 2016 [7] and observed existence significant difference among 42 wheat cultivars for root traits such as root dry matter, root length, root volume and diameter, root density and root to shoot ratio under low and high P levels. Fageria and Knupp, 2013 [10] reported significance difference ( $P < 0.01$ ) among the genotypes for plant height, root length shoot dry weight and root dry weight. Deng *et al.* 2018 [9] reported significant difference in the cultivar for above ground plant dry weight and grain yield with different levels of P; Ahadiyat *et al.*, 2014 [1]; Swamy et al., 2019 [36], reported significant difference among the test genotypes for shoot biomass and grain yield under different level of P (0, 0.20, 0.40 and 0.55 kg P<sub>2</sub>O<sub>5</sub>).

## Evaluation for the average performance for grain yield and genetic plasticity for root traits:

Selection criteria for breeder preference depends on the extent of variation in studied traits, so the recorded data for root architectural traits of ILs under low soil P and control soil P conditions were examined for the mean value ( $\Sigma x$ ), range, genetic variance components such as genotypic and phenotypic coefficient of variation (GCV and PCV) ( $\sigma^2g$  and  $\sigma^2p$ ), broad sense heritability ( $h^2$ ) and genetic advance percent mean (GAM) as shown in Table 2 along with box plot showing graphical representation of frequency distribution for each traits under both P regimes. The box indicating the existence of the 50% of our data within the box, the lower end of the box is 1<sup>st</sup> quartile ( $Q_1$ ), the upper end of the box is 3<sup>rd</sup> quartile ( $Q_3$ ) which shows the existence of the 25% of our data above the  $Q_3$  and below the  $Q_1$  we find remaining 25% of the data distribution, the range between  $Q_1$  and  $Q_3$  are called inter-quartile range with solid line indicating the median value of the data distribution, the points above the outlier are the maximum value for the traits as shown in Figure 1. Genetic variability revealed existence of wide spectrum of variability in the mean performance among the 38 ILs for all the root traits indicating the presence of sufficient genetic variability, RL was varied from 11.30 to 24.80 cm with  $\bar{X}$ =17.50 cm under  $P_0$  and 13.92 to 25.92 cm with  $\bar{X}$ =20.96 cm under normal soil P, GCV and PCV for the traits was 19.18 and 20.29 with  $h^2$  of 89.33 and GAM of 37.39 under  $P_0$ , 10.57 and 12.77 with  $h^2$  of 68.52 and GAM of 18.05 under normal soil P. RV was varied from 2.00 to 9.00 ml with  $\bar{X}$ =4.69 ml under  $P_0$  and 4.50 to 13.00 ml with  $\bar{X}$ =7.86 ml under normal soil P, GCV and PCV for the traits was 33.44 and 38.54 with  $h^2$  of 75.27 and GAM of 59.84 under  $P_0$ , 25.79 and 27.88 with  $h^2$  of 85.57 and GAM of 49.21 under normal soil P. SDW was varied from 0.34 to 0.91 g with  $\bar{X}$ =0.63 g under  $P_0$  and 0.53 to 1.30 g with  $\bar{X}$ =0.92 g under normal soil P, GCV and PCV for the traits was 40.89 and 44.05 with  $h^2$  of 86.15 and GAM of 78.29 under  $P_0$ , 28.01 and 31.72 with  $h^2$  of 77.98 and GAM of 51.02 under normal soil P. RDW was varied from 0.13 to 0.81 g with  $\bar{X}$ =0.32 g under  $P_0$  and 0.20 to 0.98 g with  $\bar{X}$ =0.52 g under normal soil P, GCV and PCV for the traits was 59.95 and 60.57 with  $h^2$  of 97.95 and GAM of 82.40 under  $P_0$ , 47.25 and 50.45 with  $h^2$  of 87.71 and GAM of 91.30 under normal soil P. GYP was varied from 3.86 to 14.70 g with

$\bar{X}$ =8.13 g under P<sub>0</sub> and 10.91 to 23.15 g with  $\bar{X}$ =16.41 g under normal soil P, GCV and PCV for the traits was 22.65 and 22.59 with  $h^2$  of 66.14 and GAM of 23.90 under P<sub>0</sub>, 20.42 and 22.66 with  $h^2$  of 84.66 and GAM of 37.82 under normal soil P respectively. The maximum range of variability reported in the current study's was reported by SL, RL, RV, SFW, RFW, SCMR and GYP while the minimum range of variability was found in the TN, SDW, RDW, RSRWW and RSRDW (Table 2), most of the root traits exhibit a wide range of variance, which provides room for enhancement of desirable types.

In the present study SL, RV, SFW, SDW, RFW, RDW, RSRWW, RSRDW and GYP were demonstrated to have high heritability in a broad sense (>60%) paired with high GAM (>20%). While, SCMR and PL revealed high heritability with moderate to high GAM, TN shows low heritability with low GAM. Since heritability value alone does not have much significance because it does not take into account the magnitude of absolute variability, the genetic progress is still a more meaningful assessment. In order to determine the projected genetic gain through selection, it is consequently required to use heritability in conjunction with selection differential or genetic advance and the expected genetic advance in *per-cent* mean were shown in Table 2. In the current study, the gain ranged from 10.59 P<sub>0</sub>: 11.19 normal soil P (TN) to 99.09 under P<sub>0</sub> (RFW) 91.30 under normal soil P (RDW) and could be reached by choosing the genotypes that make up the top 5% of all genotypes. Since high heritability estimates for quantitative traits have been found to be helpful for selection based on phenotypic performance, the present study's  $h^2$  estimates were high for most of the studied traits and ranged from 21.90% under P<sub>0</sub> : 29.77% under normal soil P (TN) to 97.95 %, under P<sub>0</sub> (RDW) to 96.17% under normal soil P (SL) indicating that a greater proportion of phenotypic variance was attributed to the genotypic variance and was less influenced by environmental effects, (Table 2) and this variation indicated the possibility of obtaining very high selection response with respect to these traits. From the literature similar kind work on root related traits and their genetic variation were reported by Fegeria, et al., 1988a [12]; and Chaubey et al., 1994 [5], Fageria et al., 2013 [11]; Zai- Hua et al., 2006 [48]; Wissuwa et al., 2002 [44]; Vejchasarn et al., 2016 [39]; Wissuwa et al., 1998 [45]; and Deng et al., 2018 [9]. Increased root length is associated with longer and more branched roots per unit of root dry matter Hill et al., 2006 [17]. Matsuo et al. 2009 [28] reported that morphological characters such as shoot weight tends to vary among different nutrient conditions.

Similarly Ozturk et al. 2005 [29] and Gunes et al. 2006 [14]; Madhusudan et al., 2022 [25] selected P efficient genotypes based on ratio of biomass weight between deficient to sufficient conditions.

### **Phenotypic correlation matrix:**

Phenotypic correlation *ie.*, the nature of mutual association of root related traits along with yield under low soil P and normal soil P for the 44 genotypes including checks were presented in Figure 2. In the present study, correlation coefficients ranged from -0.63 (SFW *vs.* RSRWW) under normal soil P to 0.87 (RFW *vs.* RDW) under P0 and (RDW *vs.* RSRDW) under normal soil P, for all root traits examined. Under normal soil P, RFW (0.64\*\*) showed highest positive significant association with grain yield per plant followed by SDW (0.59\*\*), GYP under P0 (0.52\*\*), RDW (0.42\*\*) under normal soil P, RSRWW under P0 (0.40\*\*), TN under normal soil P (0.36\*) and RV under normal soil P (0.29\*). Similarly under low soil P RSRWW (0.46\*\*) reported highest positive significant association followed by RV under normal (0.36\*), SDW under P0 and SDW under normal (0.30\*) finally with RL under P0 (0.28\*).

On the other hand the overall inter correlation among the important root attributing traits contributed to grain yield per plant through the influence of following independent traits as follows. RDW under normal soil P (0.31\*\*), RSRWW under normal soil P (0.28\*) while, under normal soil P RL revealed positive significant association with RDW with P0 (0.46\*\*), followed by RSRDW under P0 (0.42\*\*), RFW under P0 (0.40\*\*) and finally with RSRWW under P0 (0.35\*\*) *vice versa* is true. Root volume under P0 revealed positive significant association with RFW under P0 (0.43\*\*) followed by RSRWW under P0 (0.42\*\*) and SDW under P0 (0.32\*\*), while under normal soil P RV revealed positive significant association with RFW under normal soil P (0.50\*\*), followed by GYP under P0 (0.36\*\*), RSRWW under normal soil P (0.34\*\*) and finally with the GYP under normal soil P (0.29\*) and *vice versa* is true. Root dry weight under P0 showed positive significant association with RSRDW (0.83\*\*), RSRWW (0.58\*\*) under P0 and RSRDW (0.48\*\*), RDW (0.41\*\*) under normal soil P, while, under normal soil P root dry weight revealed positive significant association with RSRDW (0.87\*\*), GYP (0.42\*\*) under normal soil P and RSRDW (0.36\*\*) under P0 and *vice versa* is true. From the correlation analysis the present study revealed that highest positive association were observed for the traits

such as RDW vs. RSRDW under normal soil P, SDW vs. RDW under normal soil P, RFW vs. RDW under P0, RDW vs. SDW under P0 and SFW vs. RFW under P0 (Fig. 2). In literature similar results were reported from Gunes et al. 2006 [14] who studied correlation for root traits and revealed that selection of genotypes under low P availability in soils could use dry weight of shoot and root as indicators. Wissuwa et al. 2015 [43] studied and reported correlation for total weight, leaf weight, stem weight, root weight, dry leaf number, dry leaf weight and plant height under low P (800 µg P) and high P (1550 µg P). Georg et al. 2001 [13] revealed negative correlation of root/shoot ratio ( $r = -0.32$ ,  $p = 0.004$ ) with yield. Wissuwa, 2005 [46] correlations between P uptake under P deficiency and relative root growth were higher ( $r = 0.48$ ) than between P uptake under P deficiency and non-stress root growth potential ( $r = 0.27$ ), concluded that P deficiency reduced root growth by 41% in the most tolerant genotype, but that reduction increased to 88% in intolerant genotypes. Wissuwa et al. 1998 [45], correlation co-efficient for root traits related to P deficiency tolerance were reported in BILs of japonica and indica.

### **Clustering and Principal Components Analysis:**

For selecting the desired plant types, estimation of existing diversity among the genotypes through genetic diversity analysis plays crucial role. The compiled information on the kind and extent of genetic variability is important for selecting the best breeding lines. Analysis was carried out for root attributing traits in order to describe and to gain the better understand the source of genetic variation among the studied genotypes. The scree plot of the PCA under low soil P and normal soil P showed in Fig. 3A and 3B explained both *per cent* explained variation associated with each principle component obtained by drawing a graph. The first four component *viz.*, PC<sub>1</sub>, PC<sub>2</sub>, PC<sub>3</sub> and PC<sub>4</sub> revealed 36.40%, 12.40%, 11.50% and 9.10% of variations among the studied parameters respectively (Table 3; Fig.3A) under low soil P. The first four main PCAs are extracted from the complicated twelve PCA components, the total cumulative variance of these first four principal components (PC<sub>1</sub>, PC<sub>2</sub>, PC<sub>3</sub> and PC<sub>4</sub>) account for 69.40% of the total variation. Similarly under normal soil P, the first four component *viz.*, PC<sub>1</sub>, PC<sub>2</sub>, PC<sub>3</sub> and PC<sub>4</sub> revealed 31.90%, 16.20%, 12.40% and 9.70% of variations among the studied root parameters respectively (Table 3; Fig.3B). The first four main PCAs are extracted from the complicated twelve PCA components, the total cumulative variance of these first four principal components (PC<sub>1</sub>, PC<sub>2</sub>, PC<sub>3</sub> and PC<sub>4</sub>) account for 70.30% of the total variation.

The eigenvectors decreased significantly from PC<sub>1</sub> (4.373: 3.824) to PC<sub>5</sub> (1.038:0.980) under low soil P and normal soil P respectively, it indicates that decrease in the eigenvalues after PC<sub>5</sub>, the remaining principal components did not described much variation, thus only the first four PCs were considered which explaining much of the variation for the studied population. Elbow type with semi curve line is obtained after PC<sub>5</sub> tended to straight with minute difference observed in each PC and from the graph, it is clear that maximum variation was observed in PC<sub>1</sub> in comparison to the other four PCs, therefore the selection of lines for characters under PC<sub>1</sub> may be desirable, further principal components having more than one eigenvalue that showed more variation which act as key factor for selection of diverse breeding lines. The principle component with <1 Eigenvalue should be eliminated due to their minimum contribution towards variability. In literature similar results obtained from the Verma et al., 2019 [40], revealed PCA analysis with maximum diversity in a population of 114 rice germplasm was governed by fresh shoot weight, root volume, dry shoot weight, fresh root weight, they confirmed that the sufficient diversity and genotypes identified to be superior for one or more traits from different clusters might be useful in the hybridization programme to identify desirable segregants for the traits under study.

Results from rotated component matrix showed that the PC<sub>1</sub> and PC<sub>2</sub> which accounts for the maximum variability of 36.44%: 12.36% under P<sub>0</sub> with cumulative proportion of 36.44%: 48.80%. PC<sub>1</sub> is highly loaded with characters such as RFW (0.458), RDW (0.449), RSRDW (0.381), SFW (0.374), RSRWW (0.300), SDW (0.240), TN (0.235), RV (0.212), RL (0.185) and GYP (0.125) while, PC<sub>2</sub> is loaded with characters such as GYP (0.489), SDW (0.429), SCMR (0.420), SL (0.358), RL (0.271) and SFW (0.128) contributed in positive direction as shown in Table 3 and Fig. 6A & B in variable PCA plot explaining most contribution of each traits towards both dimensions of PCs. Further PC<sub>1</sub> and PC<sub>2</sub> confirmed the maximum variability in association with the following 14 genotypes in the positive direction (IL-11-2, IL-43-3, IL-11-4, IL-1-6, IL-42-3, IL-4-9, Rasi, IL-43-7, IL-11-4, IL-49-5, IL-21-8, IL-22-1, IL-28-1 and IL-83-6) with high degree of variability to the root traits as shown in Fig.4A with PCA biplot and Fig. 8A explaining individual genotypes contribution in the both dimensions. It clearly indicated that under low soil P genotypes belongs to the PC<sub>1</sub> and PC<sub>2</sub> with positive association related to the major traits like SL, GYP, SDW, RL SFW, TN, RDW, RSRWW, RSRDW and RFW as explained in PCA variable plot in Fig. 4B. Similarly under normal soil P results from rotated

component matrix showed that the PC<sub>1</sub> and PC<sub>2</sub> which accounts for the maximum variability 36.86%: 16.16% with cumulative proportion of 31.86%: 48.02%. PC<sub>1</sub> is highly loaded with characters such as RFW (-0.442), SDW (-0.440), RDW (-0.438), GYP (-0.361), RSRDW (-0.312), while, PC<sub>2</sub> is loaded with characters such as RSRWW (0.632), SFW (-0.541), RSRDW (-0.300), RL (0.173), RV (0.215), all the loaded characters in PC<sub>1</sub> contributed in negative direction and in PC<sub>2</sub> RSRWW, RL and RV are contributed in the positive direction while, SFW, RSRDW contributed in the negative direction as shown in Table 3 and Fig. 7A & B in variable PCA plot explaining most contribution of each traits towards both dimensions of PCs. Further PC<sub>1</sub> and PC<sub>2</sub> confirmed the maximum variability in association with the following 13 genotypes in the negative direction (IL-23-3, IL-19-6, IL-69-1, IL-43-3, IL-23-2, IL-43-1, IL-1-6, IL-42-3, IL-11-4, IL-82-1, IL-42-2 and IL-43-7) with high degree of variability to the root traits as shown in Fig.5A with PCA biplot and Fig. 8B explaining individual genotypes contribution in the both dimensions. It clearly indicated that under normal soil P genotypes belongs to the PC<sub>1</sub> and PC<sub>2</sub> with negative association related to the major traits like RSRWW, RV, GYP, SDW, RFW, RL, TN, RDW and SFW as explained in PCA variable plot in Fig. 5B. Kaysar et al., 2022 [19], with the help of PCA biplot revealed that root attributes such as RDW, RV, RFW, and RN, as well as yield-related traits including TDM, SY and GY made significant contributions to both PCs. Thus, these attributes could effectively be used as selection criteria for the genetic improvement of rice cultivars.

Cluster analysis was carried out for IL under both low soil P and normal soil P by using UPGMA hierarchical algorithm based on K means clustering, by using software Pasta 4.0 version and it is classified 44 ILs into five hierarchy (level) in P<sub>0</sub> and six clusters in normal soil P (Fig. 9A & B; Table 4), based on the degree of similarity further the members in one group are more homogeneous than members outside the group genotypes in the same group have narrow genetic diversity, the pattern of clustering confirmed the existence of a significant amount of diversity as shown in the Fig. 9A & B. Under P<sub>0</sub> the genotypes in cluster I consisted of eight ILs (ISM, IL-9-10, IL-28-3, IL-9-21, IL-23-2, IL-42-5, IL-49-5, IL-67-3), genotypes in cluster II consisted of six genotypes namely Rasi, IL-23-7, IL-21-8, IL-22-1, IL-31-3, IL-42-3. Similarly the genotypes in cluster III is grouped into 16 genotypes based on the homogeneity such as IL-1-6, IL-9-1, IL-22-6, IL-20-1, IL-28-1, IL-67-1, IL-69-2, IL-19-6, IL-82-1, IL-42-2, IL-19-3, IL-43-1, IL-83-6, IL-43-7, Swarna, IL-62-2. The genotypes in cluster IV is grouped into 9 ILs based on the

homogeneity such as IL-69-1, IL-75-2, IL-86-4, IL-4-7, IL-86-1, IL-4-5, IL-11-4, IL-11-2, IL-43-3. Genotypes with least grouping were observed in cluster V with only 4 genotypes grouped namely, Tanu, Samba Mahsuri, Ratnachudi, IL-23-3. The genotypes belongs to the cluster II and III are consisting of promising genotypes under low soil P tolerance with the traits such as GYP, SDW, RV, RL and RDW. In literature Verma et al., 2019 [40], studied 114 Noth East Indian rice genotypes for root traits and revealed that the clustering pattern obtained is determined by mainly fresh shoot weight, root volume, dry shoot weight, fresh root weight, further they grouped as Cluster I genotype was characterized by the highest root volume, fresh root weight and dry root weight. Cluster II genotype is characterized by the highest fresh shoot weight. Under normal soil P the genotypes in cluster I consisted of eight ILs and one check genotype (IL-9-10, IL-19-3, IL-23-2, IL-75-2, IL-42-3, IL-11-2, IL-67-2, IL-69-1, Swarna,), in cluster II consisted of four genotypes namely Ratnachudi, IL-43-7, IL-82-1, IL-86-1. Similarly the genotypes in cluster III is grouped into eleven genotypes based on the homogeneity such as Tanu, IL-9-1, IL-23-7, IL-42-5, IL-9-21, IL-22-6, IL-49-5, IL-67-1, ISM, IL-31-3, IL-42-2. The genotypes in cluster IV is grouped into ten ILs based on the homogeneity such as IL-4-7, IL-22-1, IL-28-1, IL-28-2, IL-11-4, IL-21-8, IL-43-1, IL-20-1, IL-28-3, IL-43-3. Genotypes in cluster V with six genotypes grouped namely, Samba Mahsuri, IL-4-5, IL-67-3, IL-69-2, IL-83-6, IL-86-4, in cluster VI with six genotypes grouped Rasi, IL-1-6, IL-23-3, IL-19-6. The genotypes belong to the cluster I and V are consisting of promising genotypes under normal soil P with higher grain yield and root traits.

### **Conclusions:**

Our results demonstrated a significant variation in root morphological traits among ILs of *O. rufipogon*, as well as a substantial and positive association between root traits such as RV, RL, SDW, RDW and grain yield.. The association studies of grain yield with root related traits reveals that, inter-correlation among the component traits such as root length, shoot length, root volume, shoot fresh and dry weight, root fresh and dry weight and root to shoot ratio on wet and dry weight basis exhibited strong association between them, even considering under stress ( $P_0$ ) and control conditions. These results showed that boosting rice yields requires improved root properties. PCA indicated that the root volume, root biomass, and grain yield are important and effective traits for rice breeding. Hierarchical clustering based on the measured traits grouped the genotypes into five and six clusters considering both  $P_0$  and normal soil P regimes respectively,

further identified the promising genotypes as IL-9-10, IL-11-2, IL-21-8, IL-19-3, IL-22-1, IL-23-2, IL-23-7, IL-31-3, IL-42-3, IL-67-2, IL-69-1, IL-75-2, Swarna and Rasi with root traits such as RV, RDW, RFW, RL, and GYP, indicating some useful synergies for selecting for high yields plus root traits in rice genotypes for low P tolerance.

### References:

1. Ahadiyat YR, Hidayat P, Susanto U. Drought tolerance, phosphorus efficiency and yield characters of upland rice lines. *Emirates Journal of Food and Agriculture*. 2014:25-34.
2. Basavaraj PS, Gireesh C, Bharamappanavara M, Manoj CA, VG IL, Ajitha V, Senguttuvel P, Sundaram RM, Anantha MS. Stress tolerance indices for the identification of low phosphorus tolerant introgression lines derived from *Oryza rufipogon* Griff. *Plant Genetic Resources*. 2021 Aug;19(4):328-38.
3. Batjes N H., A world data set of derived soil properties by FAO/UNESCO soil unit for global modelling. *Soil Use Manag*. 1997;13, 9–16.
4. Brown LK, George TS, Thompson JA, Wright G, Lyon J, Dupuy L, Hubbard SF, White PJ. What are the implications of variation in root hair length on tolerance to phosphorus deficiency in combination with water stress in barley (*Hordeum vulgare*)?. *Annals of Botany*. 2012 Jul 1;110(2):319-328.
5. Chaubey CN, Senadhira D, Gregorio GB. Genetic analysis of tolerance for phosphorous deficiency in rice (*Oryza sativa* L.). *Theoretical and Applied Genetics*. 1994 Oct;89:313-317.
6. Clark RT, MacCurdy RB, Jung JK, Shaff JE, McCouch SR, Aneshansley DJ, Kochian LV. Three-dimensional root phenotyping with a novel imaging and software platform. *Plant physiology*. 2011 Jun 1;156(2):455-465.
7. da Silva A, Bruno IP, Franzini VI, Marcante NC, Benitez L, Muraoka T. Phosphorus uptake efficiency, root morphology and architecture in Brazilian wheat cultivars. *Journal of Radioanalytical and Nuclear Chemistry*. 2016 Feb;307:1055-1063.
8. De Smet I, White PJ, Bengough AG, Dupuy L, Parizot B, Casimiro I, Heidstra R, Laskowski M, Lepetit M, Hochholdinger F, Draye X. Analyzing lateral root development: how to move forward. *The Plant Cell*. 2012 Jan 1;24(1):15-20.

9. Deng Y, Teng W, Tong YP, Chen XP, Zou CQ. Phosphorus efficiency mechanisms of two wheat cultivars as affected by a range of phosphorus levels in the field. *Frontiers in Plant Science*. 2018 Nov 6;9:1614.
10. Fageria NK, and Knupp AM. Upland rice phenology and nutrient uptake in tropical climate. *Journal of plant nutrition*. 2013 Jan 1;36(1):1-4.
11. Fageria NK, Moraes OP, Vasconcelos MJ. Upland rice genotypes evaluation for phosphorus use efficiency. *Journal of Plant Nutrition*. 2013 Oct 15;36(12):1868-1880.
12. Fageria NK, Morais OP, Baligar VC, Wright RJ. Response of rice cultivars to phosphorus supply on an oxisol. *Fertilizer research*. 1988a Jul;16:195-206.
13. George T, Magbanua R, Roder W, Van Keer K, Trébuil G, Reoma V. Upland rice response to phosphorus fertilization in Asia. *Agronomy Journal*. 2001 Nov;93(6):1362-70.
14. Gunes A, Inal A, Alpaslan M, Cakmak I. Genotypic variation in phosphorus efficiency between wheat cultivars grown under greenhouse and field conditions. *Soil Science and Plant Nutrition*. 2006 Aug 1;52(4):470-478.
15. Hammer Q, Harper DA. Past: paleontological statistics software package for education and data analysis. *Palaeontologia electronica*. 2001;4(1):1-9.
16. Hash CT, Schaffert RE, Peacock JM. Prospects for using conventional techniques and molecular biological tools to enhance performance of 'orphan' crop plants on soils low in available phosphorus. *food security in nutrient-stressed environments: Exploiting plants' genetic capabilities*. 2002:25-36.
17. Hill JO, Simpson RJ, Moore AD, Chapman DF. Morphology and response of roots of pasture species to phosphorus and nitrogen nutrition. *Plant and Soil*. 2006 Aug;286:7-19.
18. Johnson HW, Robinson HF, Comstock RE. Estimates of genetic and environmental variability in soybeans 1. *Agronomy journal*. 1955 Jul;47(7):314-318.
19. Kaysar MS, Sarker UK, Monira S, Hossain MA, Haque MS, Somaddar U, Saha G, Chaki AK, Uddin MR. Dissecting the relationship between root morphological traits and yield attributes in diverse rice cultivars under subtropical condition. *Life*. 2022 Sep 29;12(10):1519.
20. Koyama T, Chammeck C, Snitwongse P. Varietal difference of Thai rice in the resistance to phosphorus deficiency. *Tech. bull. Trop. Agric. Res. Cent*. 1973, 4, 32.

21. Londo JP, Chiang YC, Hung KH, Chiang TY, Schaal BA. Phylogeography of Asian wild rice, *Oryza rufipogon*, reveals multiple independent domestications of cultivated rice, *Oryza sativa*. *Proceedings of the National Academy of Sciences*. 2006 Jun 20;103(25):9578-983.
22. Lynch JP, and Brown KM. New roots for agriculture: exploiting the root phenome. *Philosophical Transactions of the Royal Society B: Biological Sciences*. 2012 Jun 5;367(1595):1598-1604.
23. Lynch JP. Root phenes for enhanced soil exploration and phosphorus acquisition: tools for future crops. *Plant physiology*. 2011 Jul 1;156(3):1041-1049.
24. Lynch JP. Roots of the second green revolution. *Australian Journal of Botany*. 2007 Aug 17;55(5):493-512.
25. Madhusudan N, Beulah P, Jaldhani VE, Nagaraju P, Manasa Y, Sundaram RM, Laha GS, Anantha MS, Barbadikar KM, Gireesh C, HariPrasad AS. Stacking of Pup1 QTL for low soil phosphorus tolerance and bacterial blight resistance genes in the background of APMS6B, the maintainer line of rice hybrid DRRH-3. *Euphytica*. 2022 Apr;218(4):37.
26. Majumder ND, Borthakur DN, Rakshit SC. Heterosis in rice under phosphorus stress. *Indian Journal of Genetics and Plant Breeding*. 1989 May 25;49(02):231-235.
27. Manoj CA, Muralidhara B, Basavaraj PS, Gireesh C, Sundaram RM, Senguttuvel P, Suneetha K, Rao LS, Kemparaju KB, Brajendra P, Kumar RM. Evaluation of rice genotypes for low phosphorus stress and identification of tolerant genotypes using stress tolerance indices. *INDIAN JOURNAL OF GENETICS AND PLANT BREEDING*. 2023 Apr 10;83(01):24-31.
28. Matsuo N, Ozawa K, Mochizuki T. Genotypic differences in root hydraulic conductance of rice (*Oryza sativa* L.) in response to water regimes. *Plant and Soil*. 2009 Mar;316:25-34.
29. Ozturk L, Eker S, Torun B, Cakmak I. Variation in phosphorus efficiency among 73 bread and durum wheat genotypes grown in a phosphorus-deficient calcareous soil. *Plant and soil*. 2005 Feb;269:69-80.
30. Powlson DS, Gregory PJ, Whalley WR, Quinton JN, Hopkins DW, Whitmore AP, Hirsch PR, Goulding KW. Soil management in relation to sustainable agriculture and ecosystem services. *Food policy*. 2011 Jan 1;36:S72-87.

31. R Core Team R: A language and environment for statistical computing. R Foundation for Statistical Computing, 2020, Vienna, Austria. URL <https://www.R-project.org/>.
32. Raghothama, KG. and Karthikeyan, AS. Phosphate acquisition. *Plant Soil* 2005, 274, 37–49.
33. Shimizu A, Kato K, Komatsu A, Motomura K, Ikehashi H. Genetic analysis of root elongation induced by phosphorus deficiency in rice (*Oryza sativa* L.): fine QTL mapping and multivariate analysis of related traits. *Theoretical and Applied Genetics*. 2008 Oct;117:987-96.
34. Shimizu A, Yanagihara S, Kawasaki S, Ikehashi H. Phosphorus deficiency-induced root elongation and its QTL in rice (*Oryza sativa* L.). *Theoretical and Applied Genetics*. 2004 Nov;109:1361-1368.
35. Sivasubramanian J and Madhavamenon P. Genotypic and phenotypic variability in rice., *Madras Agric. J.*1973, 12: 15-16.
36. Swamy HM, Anila M, Kale RR, Bhadana VP, Anantha MS, Brajendra P, Hajira SK, Balachiranjeevi CH, Prasanna BL, Pranathi K, Dilip T. Phenotypic and molecular characterization of rice germplasm lines and identification of novel source for low soil phosphorus tolerance in rice. *Euphytica*. 2019 Jul;215:1-5.
37. Tiessen H. Phosphorus in the global environment. In the ecophysiology of plant-phosphorus interactions 2008 Jun 3 (pp. 1-7). Dordrecht: Springer Netherlands.
38. Vance CP, Uhde- Stone C, Allan DL. Phosphorus acquisition and use: critical adaptations by plants for securing a nonrenewable resource. *New phytologist*. 2003 Mar;157(3):423-447.
39. Vejchasarn P, Lynch JP, Brown KM. Genetic variability in phosphorus responses of rice root phenotypes. *Rice*. 2016 Dec;9(1):1-6.
40. Verma H, Borah JL, Sarma RN. Variability assessment for root and drought tolerance traits and genetic diversity analysis of rice germplasm using SSR markers. *Scientific reports*. 2019 Nov 11;9(1):16513.
41. Vinod KK, and Heuer S. Approaches towards nitrogen-and phosphorus-efficient rice. *AoB Plants*. 2012 Jan 1;2012:pls028.

42. Wissuwa M, and Ae N. Genotypic variation for tolerance to phosphorus deficiency in rice and the potential for its exploitation in rice improvement. *Plant breeding*. 2001 Feb;120(1):43-48.
43. Wissuwa M, Kondo K, Fukuda T, Mori A, Rose MT, Pariasca-Tanaka J, Kretzschmar T, Haefele SM, Rose TJ. Unmasking novel loci for internal phosphorus utilization efficiency in rice germplasm through genome-wide association analysis. *PLoS One*. 2015 Apr 29;10(4):e0124215.
44. Wissuwa M, Wegner J, Ae N, Yano M. Substitution mapping of Pup1: a major QTL increasing phosphorus uptake of rice from a phosphorus-deficient soil. *Theoretical and Applied Genetics*. 2002 Nov;105:890-897.
45. Wissuwa M, Yano M, Ae N. Mapping of QTLs for phosphorus-deficiency tolerance in rice (*Oryza sativa* L.). *Theoretical and Applied Genetics*. 1998 Oct;97:777-783.
46. Wissuwa M. Combining a modelling with a genetic approach in establishing associations between genetic and physiological effects in relation to phosphorus uptake. *Plant and Soil*. 2005 Feb;269:57-68.
47. Yan X, Liao H, Beebe SE, Blair MW, Lynch JP. QTL mapping of root hair and acid exudation traits and their relationship to phosphorus uptake in common bean. *Plant and soil*. 2004 Aug;265:17-29.
48. Zai-Hua GU, Ping DI, Li-Yuan HE, Cai-Guo XU. Genetic analysis of agricultural traits in rice related to phosphorus efficiency. *Acta Genetica Sinica*. 2006 Jul 1;33(7):634-441.

**Table 1. Analysis of variance for root architecture trait of introgression lines under low soil P and normal soil P conditions during Kharif-2020**

Traits	Environment /conditions	Mean sum of squares						
		Blocks	Entries	Checks	Genotypes	Genotypes vs. Checks	Residuals	CV (%)
<i>Degrees of freedom</i>		1	43	5	37	1	5	
TN	Low soil P	0.02*	0.40 *	0.12	0.38 *	0.46	0.07	10.43
	Normal soil P	0.05	0.39	0.31	0.30*	0.01	0.21	15.29
SL	Low soil P	454.57 **	81.28 **	122.01 **	87.81 **	88.85 **	3.24	3.28
	Normal soil P	73.84 **	62.18 **	46.08 **	49.12 **	7.19	1.88	2.42
RL	Low soil P	27.75 **	18.69 **	15.77 **	18.97 **	50.64 **	1.30	5.37
	Normal soil P	2.31*	5.64	5.73	5.83*	0.03	1.83	7.17
RV	Low soil P	1.09	3.78 *	3.34 *	3.56 *	15.29 **	0.60	16.25
	Normal soil P	1.77*	5.68 **	4.67 *	3.69 *	42.22 **	0.53	10.26
SFW	Low soil P	22.51 *	23.6 **	9.29	25.06 **	62.74 **	2.15	17.61
	Normal soil P	5.41	15.50 **	13.16 *	13.48 *	6.59	1.66	11.66
SDW	Low soil P	0.001	0.47 **	0.23 **	0.49 **	1.28 **	0.01	4.95
	Normal soil P	0.64 *	0.33	0.32	0.34 *	0.14	0.08	14.78
RFW	Low soil P	5.21 **	4.82 **	2.80	4.91 **	16.77 **	0.26	14.76
	Normal soil P	1.83	5.24 *	4.98	3.44	63.69 **	0.96	16.90
RDW	Low soil P	0.09 *	0.04 *	0.01	0.02 *	0.06 *	0.01	26.48
	Normal soil P	0.12 **	0.08 **	0.06 **	0.05 *	0.38 **	0.01	16.89
RSRWW	Low soil P	0.03	0.06 *	0.02	0.06 *	0.03	0.01	22.19
	Normal soil P	0.05 **	0.04 **	0.06 **	0.03 **	0.41 **	0.00	7.88
RSRDW	Low soil P	0.06 **	0.02 **	0.01 **	0.02 **	0.18 **	0.00	7.38
	Normal soil P	0.17 **	0.04 *	0.02 *	0.09 *	0.05 *	0.01	28.26
SCMR	Low soil P	4.24	14.98 *	20.15 *	13.38	40.84 *	3.16	4.58
	Normal soil P	3.84	16.93	56.37 **	8.70 *	127.69 **	1.62	3.91
GYP	Low soil P	0.58**	1.76 **	3.19 *	1.29 **	11.85 **	0.63	15.47
	Normal soil P	0.57*	3.18 *	2.93 *	3.24 *	1.21	0.50	8.44

**Note1:** TN: Tiller numbers/plant; SL: Shoot length (cm); RL: Root length (cm); RV: Root volume (cm); SFW: Shoot fresh weight (g); SDW: Shoot dry weight (g); RFW: Root fresh weight (g); RDW: Root dry weight (g); RSRWW: Root to shoot ratio on wet weight basis; RSRDW: Root to shoot ratio on dry weight basis; SCMR: SPAD Chlorophyll Meter Reading; GYP: Grain yield per plant (g)

**Note 2:** \* Indicate significance @ 5% level; \*\* Indicate significance @ 1% level; Entries (checks + Genotypes), CD<sub>(0.05)</sub> D: Test treatment and control treatment, CV (%): Coefficient of variation; Low soil P (P<sub>0</sub>): P level:3-5ppm; Normal soil P: RDF for rice

UNDER PEER REVIEW

**Table 2. Genetic plasticity and mean performance for root architectural traits of ILs under low soil P and normal soil P conditions during Kharif-2020**

Sl. No.	Traits	Environment /conditions	Phenotypic variability			Coefficient of variation (%)		h <sup>2</sup> (bs)	GAM (5%)
			Min	Max	Mean	GCV	PCV		
1	TN	Low soil P	1.50	3.29	2.47	10.97	23.44	21.90	10.59
		Normal soil P	1.69	4.00	3.13	9.94	18.23	29.77	11.19
2	SL	Low soil P	28.89	60.07	37.45	15.75	16.97	86.11	30.15
		Normal soil P	39.25	69.50	57.59	12.15	12.39	96.17	24.57
3	RL	Low soil P	11.30	24.80	17.50	19.18	20.29	89.33	37.39
		Normal soil P	13.92	25.92	20.96	10.57	12.77	68.52	18.05
4	RV	Low soil P	2.00	9.00	4.69	33.44	38.54	75.27	59.84
		Normal soil P	4.50	13.00	7.86	25.79	27.88	85.57	49.21
5	SFW	Low soil P	3.71	20.19	9.17	52.23	55.02	90.10	58.28
		Normal soil P	4.10	22.36	11.98	31.42	33.54	87.72	60.70
6	SDW	Low soil P	0.34	0.91	0.63	40.89	44.05	86.15	78.29
		Normal soil P	0.53	1.30	0.92	28.01	31.72	77.98	51.02
7	RFW	Low soil P	1.14	11.83	3.89	52.25	56.84	84.51	99.09
		Normal soil P	3.06	13.24	7.50	28.39	33.48	71.93	49.67
8	RDW	Low soil P	0.13	0.81	0.32	59.95	60.57	97.95	82.40
		Normal soil P	0.20	0.98	0.52	47.25	50.45	87.71	91.30
9	RSRWW	Low soil P	0.11	0.70	0.41	29.36	30.49	92.75	58.33
		Normal soil P	0.32	0.96	0.66	25.16	26.21	90.18	47.24
10	RSRDW	Low soil P	0.20	0.89	0.50	28.97	33.41	75.16	51.81
		Normal soil P	0.32	0.90	0.55	71.06	76.78	85.66	35.68
11	SCMR	Low soil P	31.60	44.80	39.05	8.28	9.47	76.36	14.92
		Normal soil P	25.30	40.12	32.51	8.56	9.18	81.39	15.41
112	GYP	Low soil P	3.86	14.70	8.13	22.65	25.59	66.14	23.90
		Normal soil P	10.91	23.15	16.41	20.42	22.66	84.66	37.82

**Note1:** PCV and GCV: Phenotypic and genotypic coefficient of variation h<sup>2</sup>(bs): Heritability (broad sense), GA: Genetic advance, GAM: Genetic advance as per cent of mean

**Note2:** TN: Tiller numbers/plant; SL: Shoot length (cm); RL: Root length (cm); RV: Root volume (cm); SFW: Shoot fresh weight (g); SDW: Shoot dry weight (g); RFW: Root fresh weight (g); RDW: Root dry weight (g); RSRWW: Root to shoot ratio on wet weight basis; RSRDW: Root to shoot ratio on dry weight basis; SCMR: SPAD Chlorophyll Meter Reading; GYP: Grain yield per plant (g); Low soil P (P<sub>0</sub>): P level:3-5ppm; Normal soil P: RDF for rice

**Note 3:** GCV, PCV and GAM was classified as High (> 20%); Moderate (10-20%); Low (<10%) as proposed by Sivasubramanian and Madhavamenon (1973) [35]; (h<sup>2</sup>) estimates were categorized as: High (> 60%); Moderate (30-60%); Low (0-30%); GAM estimates were categorized as: High (> 20%); Moderate (10-20%); Low (<10%) suggested by Johnson et al. 1955 [18].

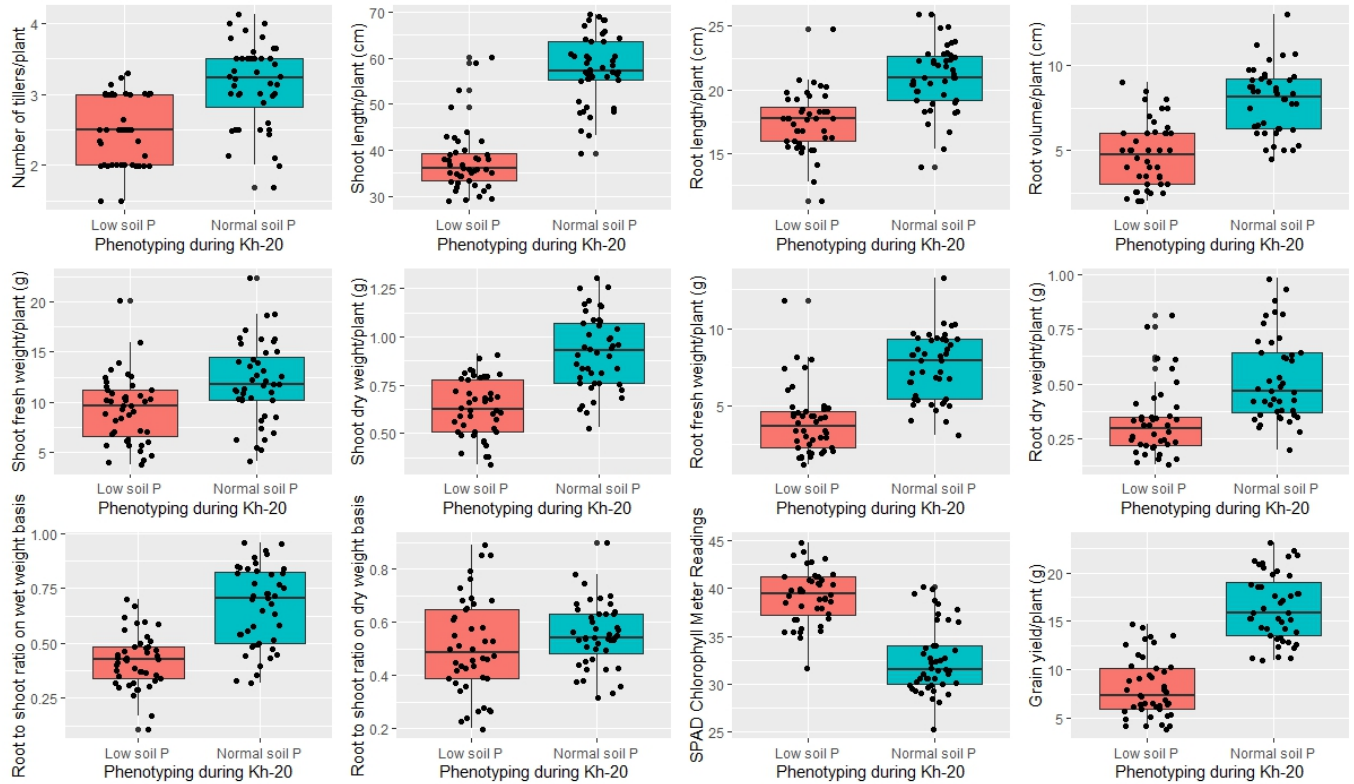

**Figure 1: Box plots showing frequency distribution for root architectural traits of introgression lines under under low soil P and normal soil P conditions during Kharif-2020**

**Note:** Red colour box showing the frequency distribution of rice population's low soil P

Blue colour box showing the frequency distribution of rice population's normal soil P

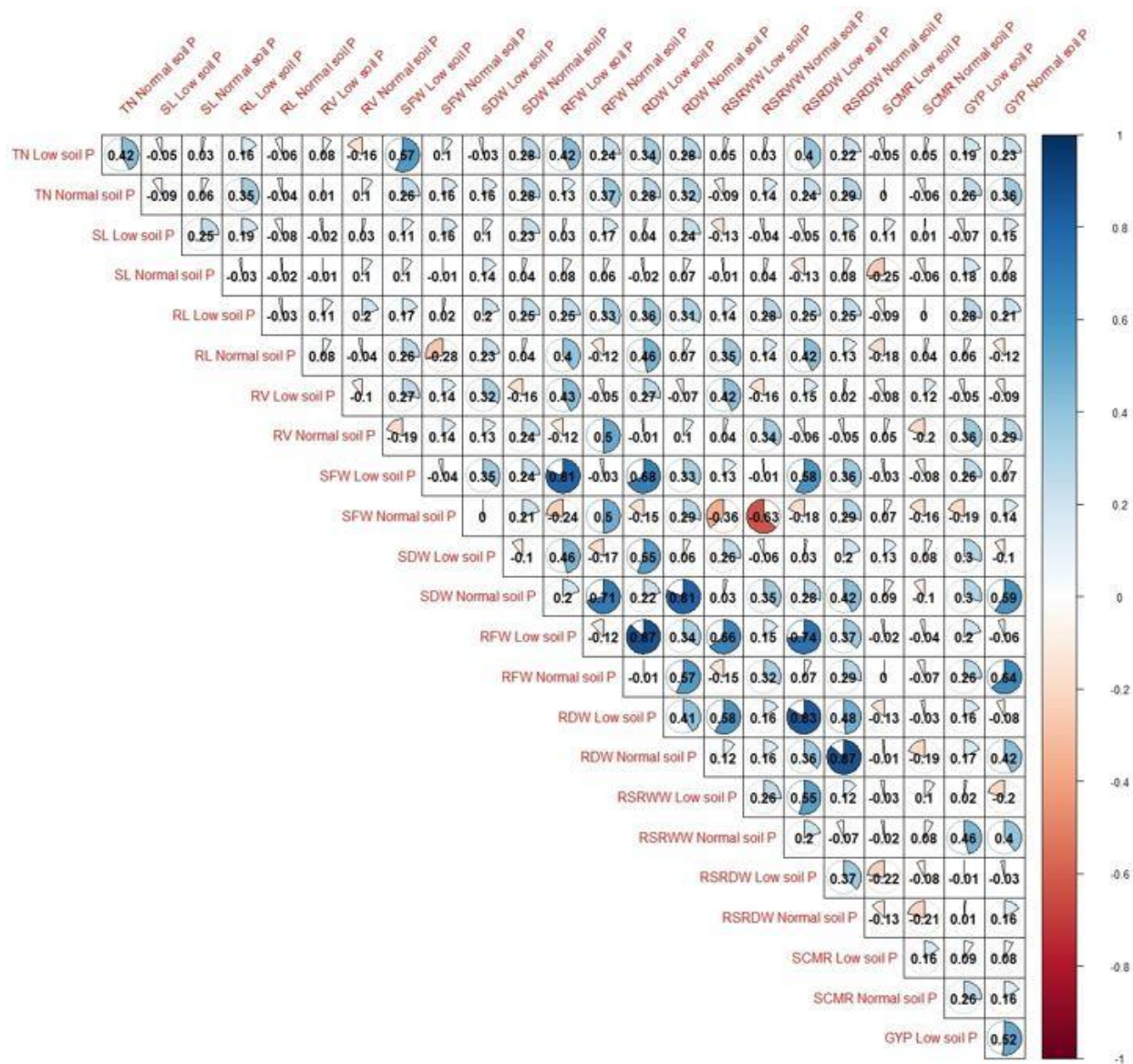

Figure 2: Phenotypic correlation coefficient matrix for root architectural traits of ILs under **under low soil P and normal soil P conditions** during *Kharif-2020*

**Note1: Traits details:** TN: Tiller numbers/plant; SL: Shoot length (cm); RL: Root length (cm); RV: Root volume (cm); SFW: Shoot fresh weight (g); SDW: Shoot dry weight (g); RFW: Root fresh weight (g); RDW: Root dry weight (g); RSRWW: Root to shoot ratio on wet weight basis; RSRDW: Root to shoot ratio on dry weight basis; SCMR: SPAD Chlorophyll Meter Reading; GYP: Grain yield per plant (g); Low soil P (P<sub>0</sub>): P level:3-5ppm; Normal soil P: RDF for rice

**Note2:** Positive and negative correlations are indicated by blue and red ellipses. A greater coefficient is reflected by a color of higher intensity; Significance level: 0.05 (\*) = 0.287; 0.01 (\*\*\*) = 0.372

**Table 3: Eigen values, Per cent variance, cumulative proportion and component loading for root architectural traits of ILs under **under low soil P and normal soil P conditions** during *Kharif-2020***

Traits	Environment /conditions	PC1	PC2	PC3	PC4	PC5	PC6	PC7
TN	Low soil P	0.235	-0.020	0.548	0.153	-0.196	0.214	-0.360
	Normal soil P	-0.260	-0.005	0.006	0.133	-0.257	-0.744	0.496
SL	Low soil P	0.012	0.358	0.016	-0.770	-0.232	0.010	0.032
	Normal soil P	-0.062	0.026	0.017	-0.369	-0.881	0.268	-0.006
RL	Low soil P	0.185	0.271	0.094	-0.331	0.585	-0.128	-0.461
	Normal soil P	0.023	0.173	-0.539	-0.124	0.157	0.324	0.671
RV	Low soil P	0.212	-0.087	-0.438	0.000	-0.066	0.620	-0.460
	Normal soil P	-0.210	0.215	0.383	-0.469	0.216	0.157	0.267
SFW	Low soil P	0.379	0.128	0.283	0.020	-0.285	0.242	0.169
	Normal soil P	-0.200	-0.541	0.336	0.075	0.061	0.212	0.243
SDW	Low soil P	0.240	0.429	-0.395	0.097	0.038	0.169	0.397
	Normal soil P	-0.440	0.079	-0.102	0.071	0.109	0.155	-0.213
RFW	Low soil P	0.458	-0.019	-0.049	0.036	-0.147	-0.038	0.033
	Normal soil P	-0.442	0.046	0.268	0.017	0.096	0.136	0.109
RDW	Low soil P	0.449	-0.024	-0.033	-0.076	0.042	-0.167	0.249
	Normal soil P	-0.438	-0.145	-0.336	0.028	0.021	0.072	-0.209
RSRWW	Low soil P	0.300	-0.257	-0.417	0.078	0.084	-0.342	-0.205
	Normal soil P	-0.165	0.632	-0.086	-0.105	0.046	-0.147	-0.185
RSRDW	Low soil P	0.381	-0.327	0.174	-0.120	0.001	-0.309	0.052
	Normal soil P	-0.312	-0.300	-0.453	-0.009	-0.059	-0.022	-0.076
SCMR	Low soil P	-0.052	0.420	-0.152	0.214	-0.551	-0.473	-0.389
	Normal soil P	0.087	0.236	0.051	0.714	-0.210	0.360	0.181
GYP	Low soil P	0.125	0.489	0.178	0.438	0.381	-0.019	0.018
	Normal soil P	-0.361	0.235	0.197	0.279	-0.110	0.030	-0.029
Eigen value	Low soil P	<b>4.373</b>	<b>1.483</b>	<b>1.386</b>	<b>1.090</b>	<b>1.038</b>	<b>0.860</b>	<b>0.722</b>
	Normal soil P	<b>3.824</b>	<b>1.930</b>	<b>1.480</b>	<b>1.150</b>	<b>0.980</b>	<b>0.820</b>	<b>0.760</b>
Proportion of variance	Low soil P	<b>36.44</b>	<b>12.36</b>	<b>11.54</b>	<b>9.08</b>	<b>8.64</b>	<b>7.16</b>	<b>6.01</b>
	Normal soil P	<b>31.86</b>	<b>16.16</b>	<b>12.35</b>	<b>9.65</b>	<b>8.18</b>	<b>6.84</b>	<b>6.37</b>
Cumulative proportion	Low soil P	<b>36.44</b>	<b>48.80</b>	<b>60.34</b>	<b>69.43</b>	<b>78.08</b>	<b>85.24</b>	<b>91.26</b>
	Normal soil P	<b>31.86</b>	<b>48.02</b>	<b>60.38</b>	<b>70.03</b>	<b>78.22</b>	<b>85.07</b>	<b>91.45</b>

**Note1:** TN: Tiller numbers/plant; SL: Shoot length (cm); RL: Root length (cm); RV: Root volume (cm); SFW: Shoot fresh weight (g); SDW: Shoot dry weight (g); RFW: Root fresh weight (g); RDW: Root dry weight (g); RSRWW: Root to shoot ratio on wet weight basis; RSRDW: Root to shoot ratio on dry weight basis; SCMR: SPAD Chlorophyll Meter Reading; GYP: Grain yield per plant (g); Low soil P ( $P_0$ ): P level:3-5ppm; Normal soil P: RDF for rice; PC1 to PC7: Principal components

Scree plot

Fig. 3A

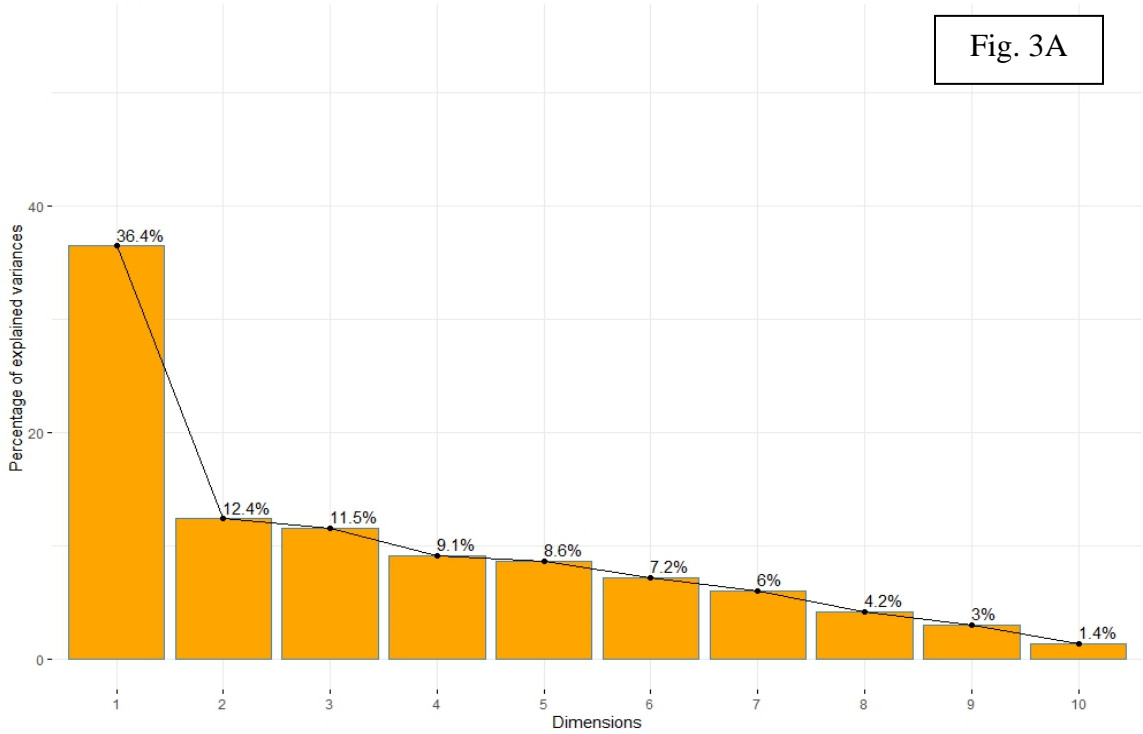

Scree plot

Fig. 3B

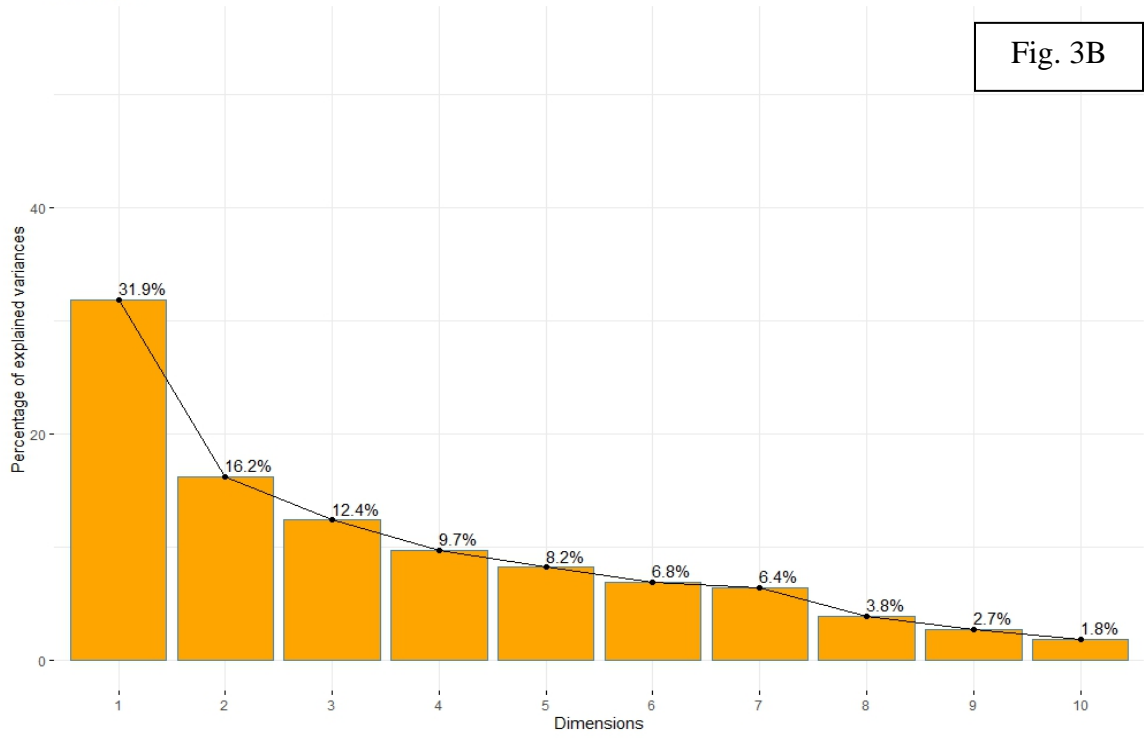

Fig. 3 (A&B): Scree plot showing percentage of explained variance for root architectural traits of introgression lines **under low soil P and normal soil P conditions** during Kharif-2020; Fig.3A: percentage of explained variance under low soil P; Fig.3B: percentage of explained variance under normal soil P; Note: 1 to 10 number = component numbers

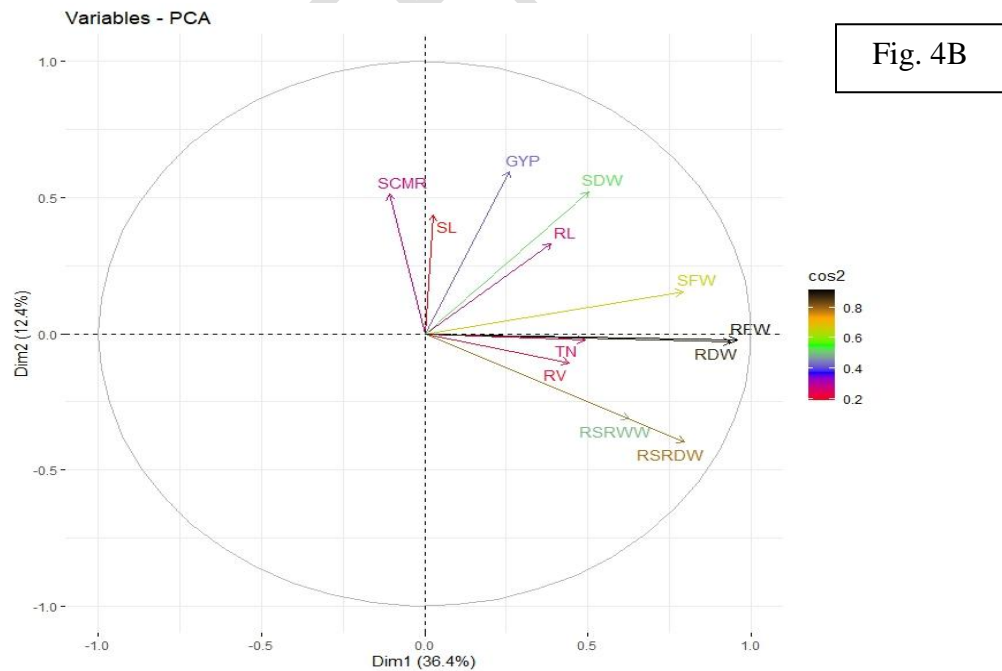
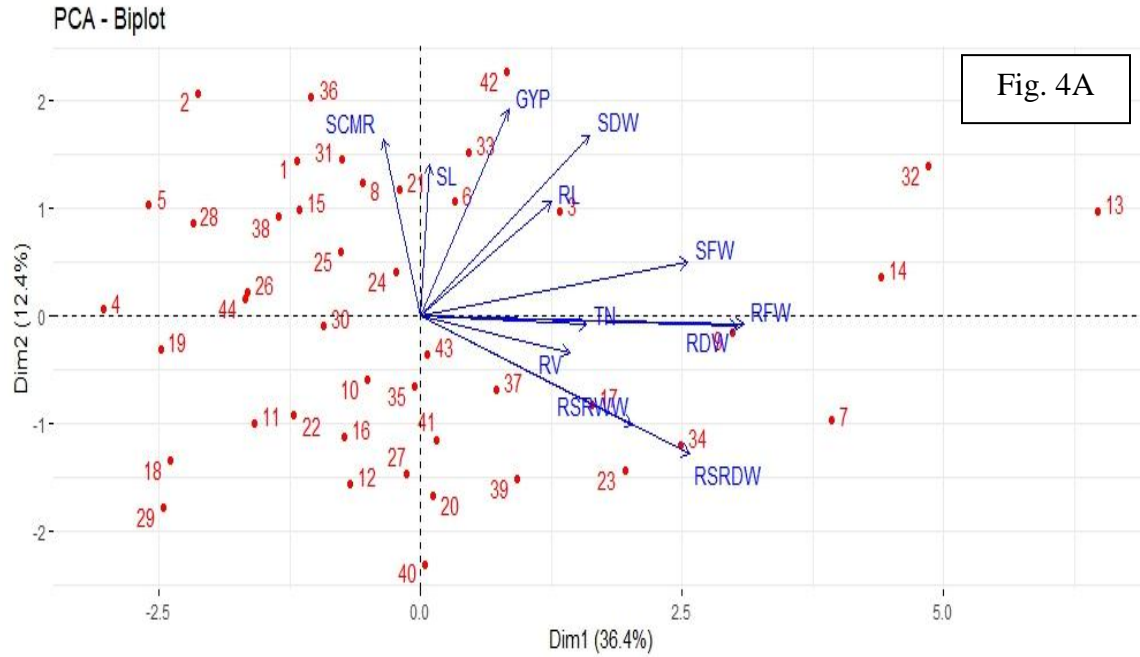
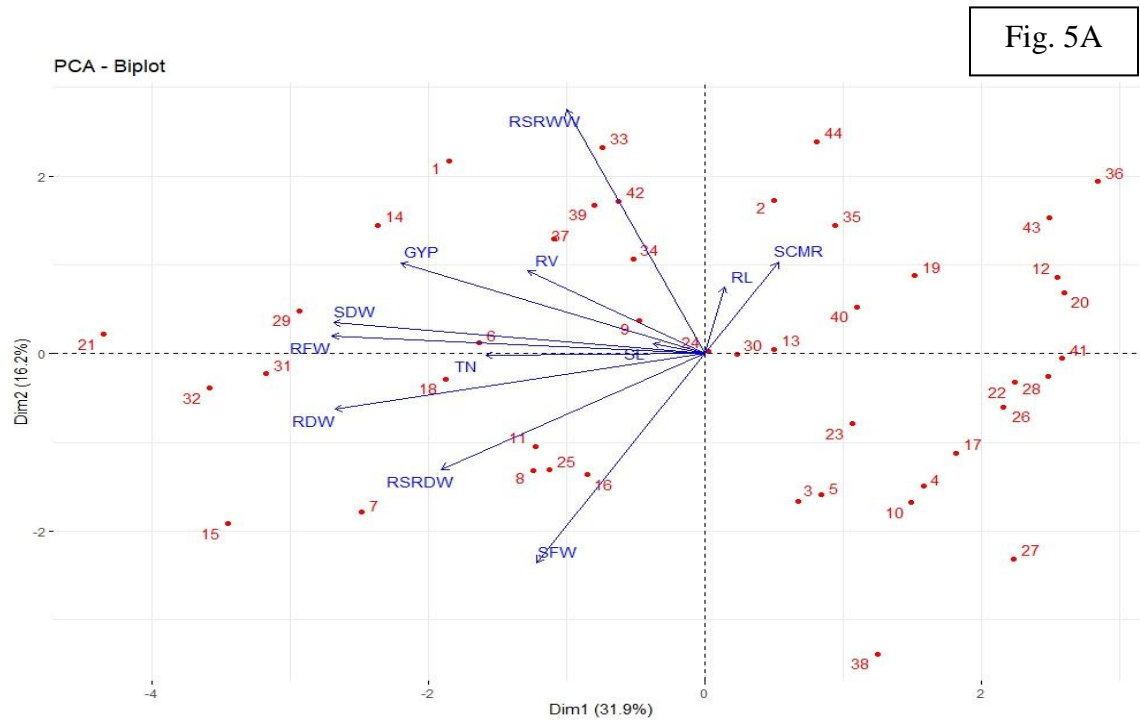
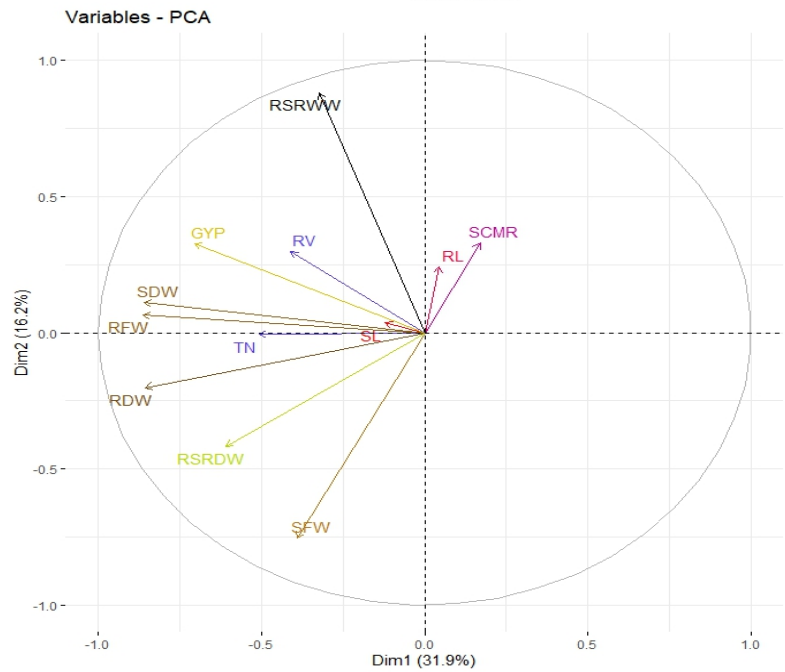

Figure 4: A and B showing the PCA Biplot for genotype clustering and PCA variable showing the contribution of the root traits in PC1 and PC2 on the axes for introgression lines **under low soil P and normal soil P conditions** during Kharif-2020

**Note:** 1: Swarna, 2: Ratnachudi, 3: Tanu, 4: ISM, 5: Rasi, 6: Samba mahsuri, 7: IL1-6, 8: IL4-5, 9: IL4-7, 10: IL9-1, 11: IL9-10, 12: IL9-21, 13: IL11-2, 14: IL11-4, 15: IL19-6, 16: IL20-1, 17: IL19-3, 18: IL21-8, 19: IL22-1, 20: IL22-6, 21: IL23-3, 22: IL23-7, 23: IL28-1, 24: IL28-2, 25: IL28-3, 26: IL31-3, 27: IL23-2, 28: IL42-2, 29: IL42-3, 30: IL42-5, 31: IL43-1, 32: IL43-3, 33: IL43-7, 34: IL49-5, 35: IL67-1, 36: IL67-2, 37: IL67-3, 38: IL69-1, 39: IL69-2, 40: IL75-2, 41: IL82-1, 42: IL83-6, 43: IL86-1, 44: IL86-4



**Fig. 5A**



**Fig. 5B**

**Figure 5: A and B showing the PCA Biplot for genotype clustering and PCA variable showing the contribution of the root traits in PC1 and PC2 on the axes under normal soil P during Kharif-2020**

**Note:** 1: Swarna, 2: Ratnachudi, 3: Tanu, 4: ISM, 5: Rasi, 6: Samba mahsuri, 7: IL1-6, 8: IL4-5, 9: IL4-7, 10: IL9-1, 11: IL9-10, 12: IL9-21, 13: IL11-2, 14: IL11-4, 15: IL19-6, 16: IL20-1, 17: IL19-3, 18: IL21-8, 19: IL22-1, 20: IL22-6, 21: IL23-3, 22: IL23-7, 23: IL28-1, 24: IL28-2, 25: IL28-3, 26: IL31-3, 27: IL23-2, 28: IL42-2, 29: IL42-3, 30: IL42-5, 31: IL43-1, 32: IL43-3, 33: IL43-7, 34: IL49-5, 35: IL67-1, 36: IL67-2, 37: IL67-3, 38: IL69-1, 39: IL69-2, 40: IL75-2, 41: IL82-1, 42: IL83-6, 43: IL86-1, 44: IL86-4

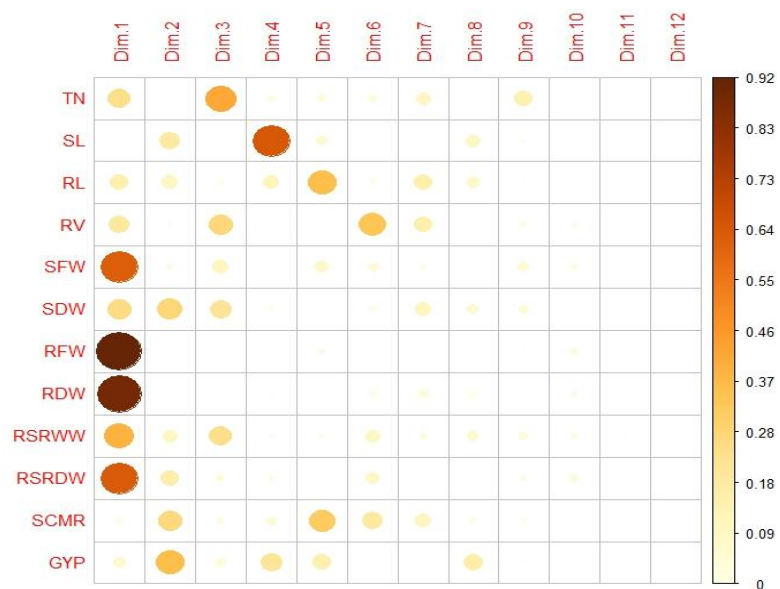

Fig. 6A

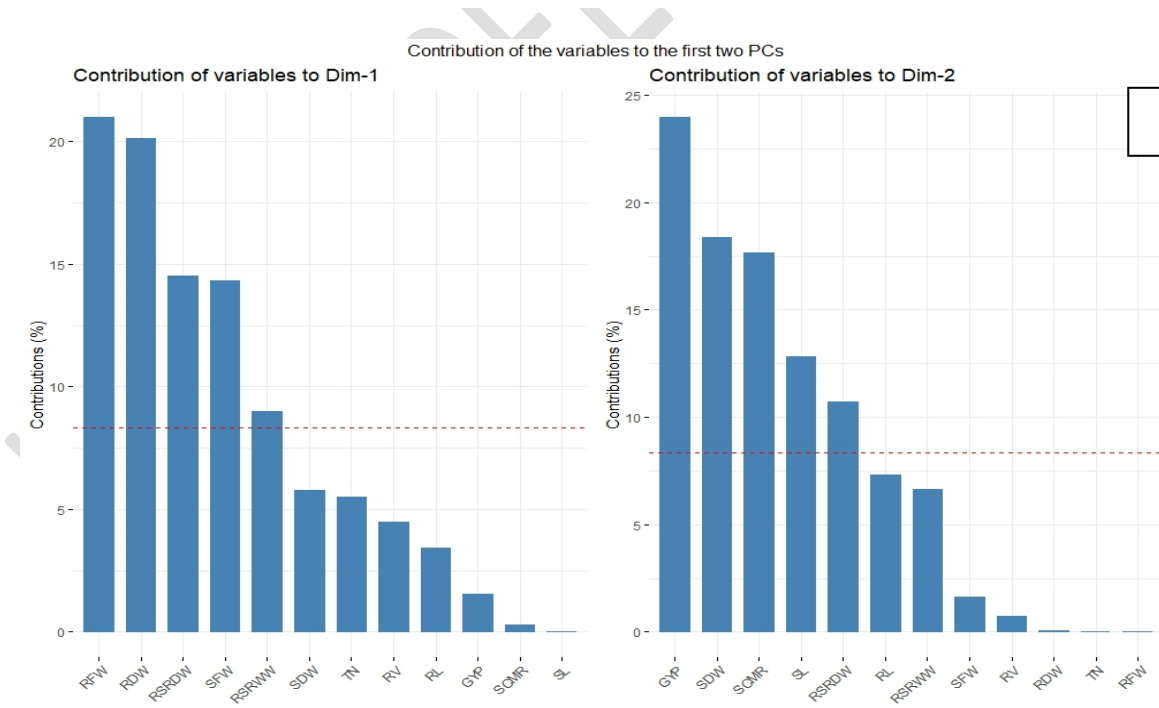
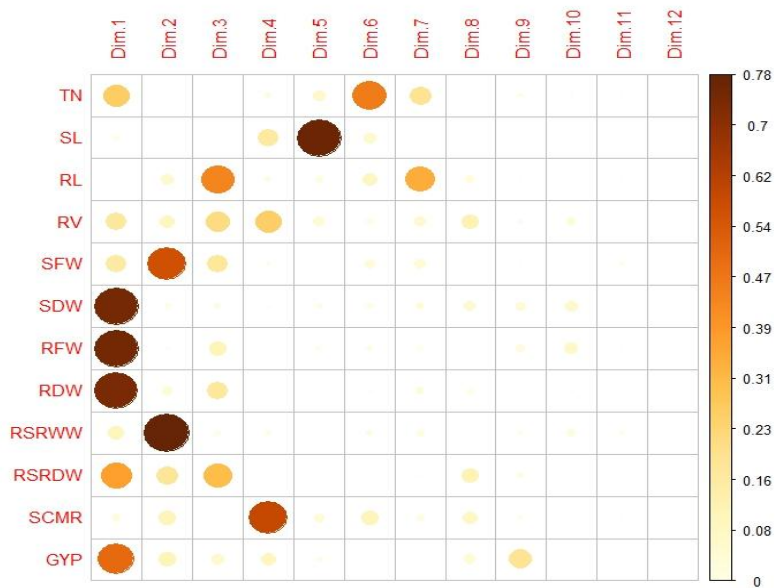

Fig. 6B

**Figure 6: A and B showing the PCA showing most contributing variables for each dimensions and contributions of the variables for 1<sup>st</sup> two PCs under low soil P during Kharif-2020**

Fig. 7A



Contribution of the variables to the first two PCs

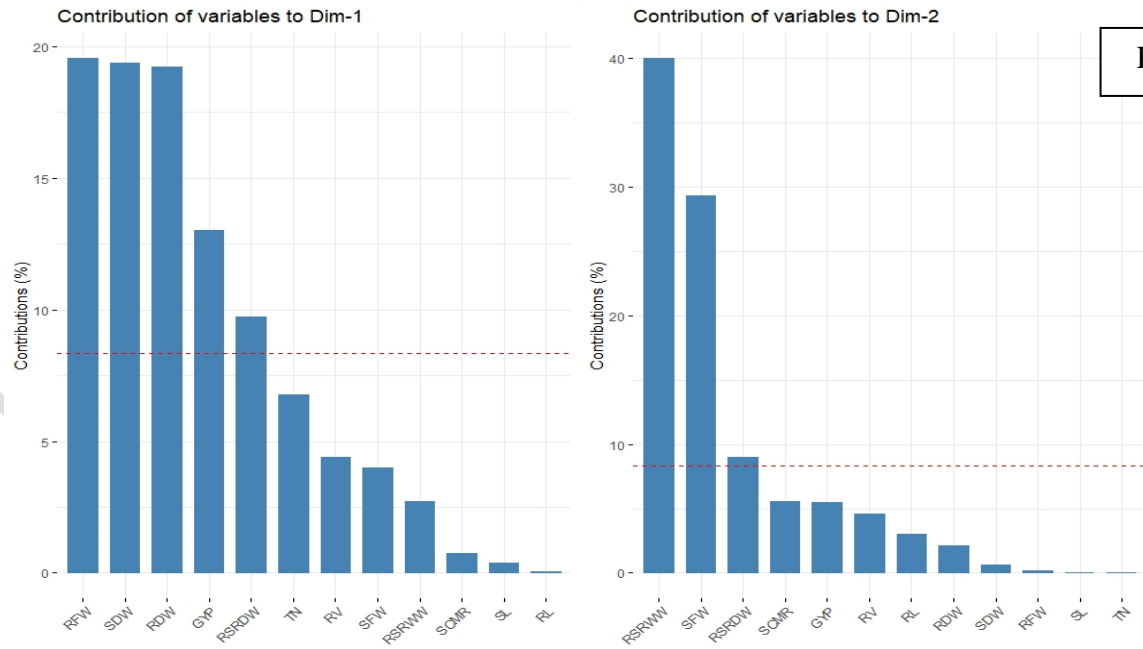

Fig. 7B

Figure 7: A and B showing the PCA showing most contributing variables for each dimensions and contributions of the variables for 1<sup>st</sup> two PCs under normal soil P during *Kharif-2020*

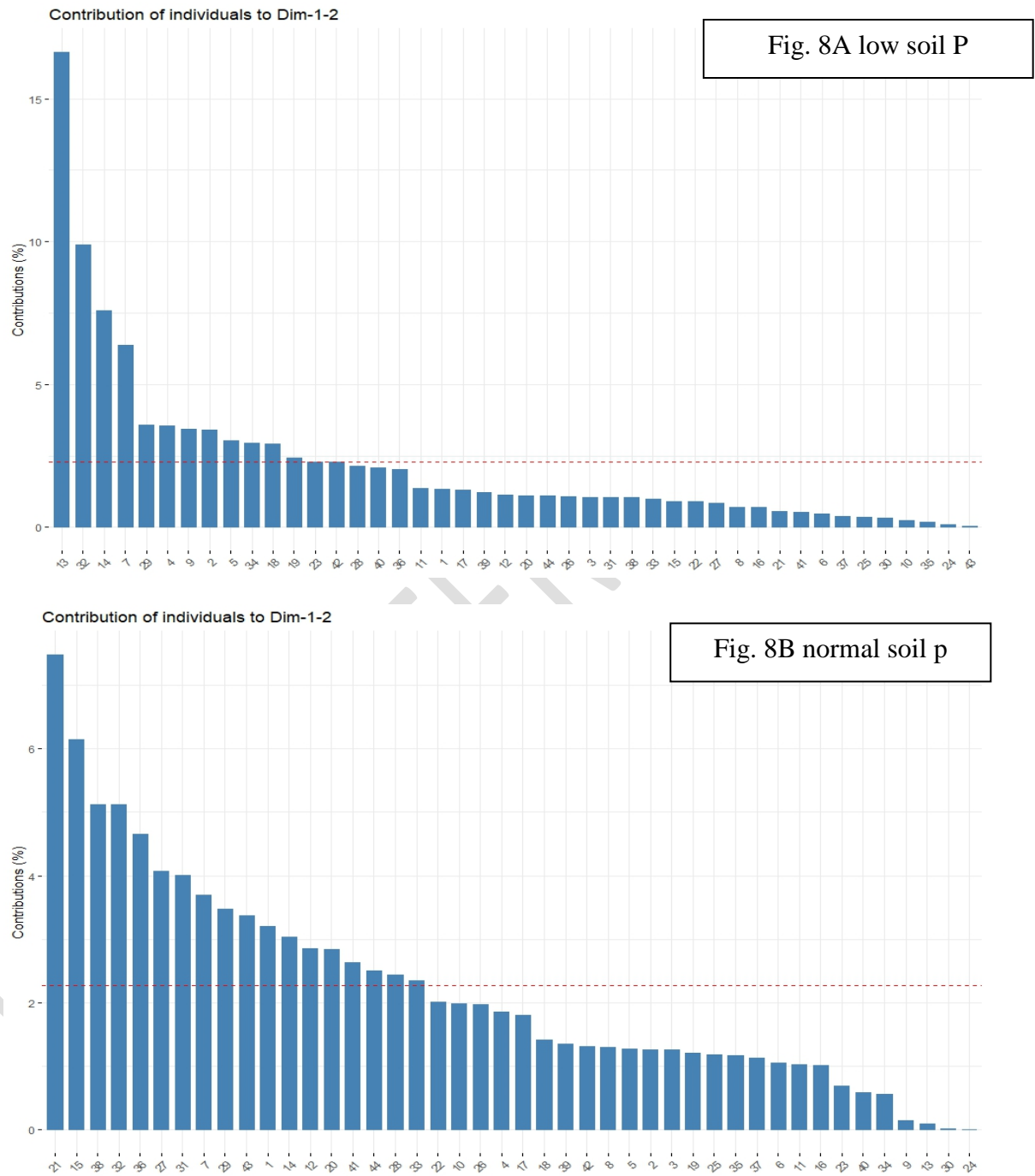

Figure 8: A and B showing the PCA graphs for individual genotype contributing to the variability through first two PCs for root architectural traits of introgression lines under **under low soil P and normal soil P conditions** during *Kharif-2020*

**Note:** 1: Swarna, 2: Ratnachudi, 3: Tanu, 4: ISM, 5: Rasi, 6: Samba mahsuri, 7: IL1-6, 8: IL4-5, 9: IL4-7, 10: IL9-1, 11: IL9-10, 12: IL9-21, 13: IL11-2, 14: IL11-4, 15: IL19-6, 16: IL20-1, 17: IL19-3, 18: IL21-8, 19: IL22-1, 20: IL22-6, 21: IL23-3, 22: IL23-7, 23: IL28-1, 24: IL28-2, 25: IL28-3, 26: IL31-3, 27: IL23-2, 28: IL42-2, 29: IL42-3, 30: IL42-5, 31: IL43-1, 32: IL43-3, 33: IL43-7, 34: IL49-5, 35: IL67-1, 36: IL67-2, 37: IL67-3, 38: IL69-1, 39: IL69-2, 40: IL75-2, 41: IL82-1, 42: IL83-6, 43: IL86-1, 44: IL86-4

UNDER PEER REVIEW

Fig. 9A

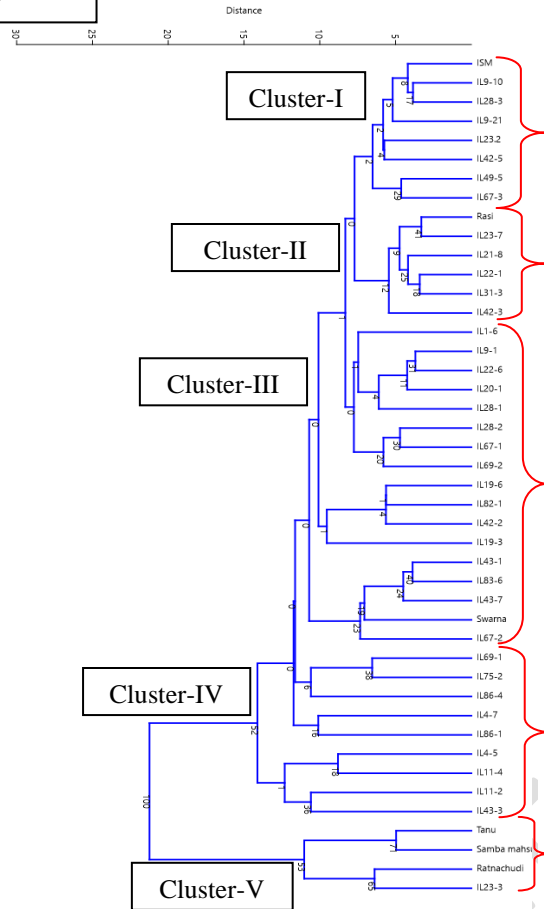
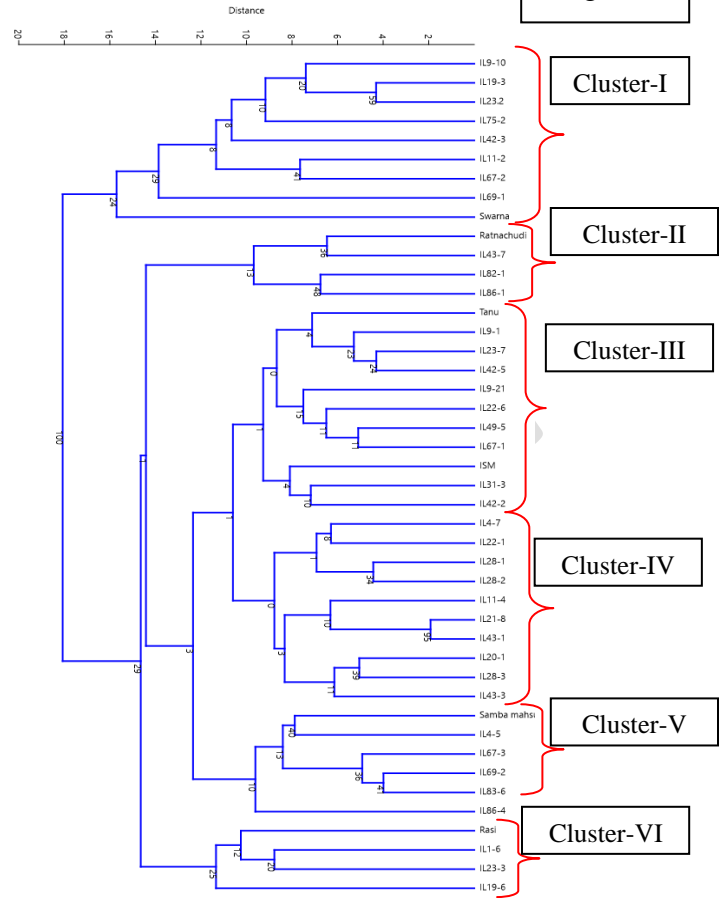

Fig. 9B



**Figure 9: (A&B): Relationship among root architectural traits of introgression lines under low soil P and normal soil P conditions during Kharif-2020 using K means clustering on UPGMA method.**

**Note:1:** Fig.9A: clustering of root traits under low soil P; Fig.9B: clustering of root traits under normal soil P

**Table 4. Grouping of introgression lines based on root traits by using K means clustering on UPGMA method**

	Low soil P		Normal soil P
Clusters	Genotypes	Clusters	Genotypes
I	ISM, IL-9-10, IL-28-3, IL-9-21, IL-23-2, IL-42-5, IL-49-5, IL-67-3	I	IL-9-10, IL-19-3, IL-23-2, IL-75-2, IL-42-3, IL-11-2, IL-67-2, IL-69-1, Swarna,
II	Rasi, IL-23-7, IL-21-8, IL-22-1, IL-31-3, IL-42-3	II	Ratnachudi, IL-43-7, IL-82-1, IL-86-1
III	IL-1-6, IL-9-1, IL-22-6, IL-20-1, IL-28-1, IL-67-1, IL-69-2, IL-19-6, IL-82-1, IL-42-2, IL-19-3, IL-43-1, IL-83-6, IL-43-7, Swarna, IL-62-2	III	Tanu, IL-9-1, IL-23-7, IL-42-5, IL-9-21, IL-22-6, IL-49-5, IL-67-1, ISM, IL-31-3, IL-42-2
IV	IL-69-1, IL-75-2, IL-86-4, IL-4-7, IL-86-1, IL-4-5, IL-11-4, IL-11-2, IL-43-3	IV	IL-4-7, IL-22-1, IL-28-1, IL-28-2, IL-11-4, IL-21-8, IL-43-1, IL-20-1, IL-28-3, IL-43-3
V	Tanu, Samba Mahsuri, Ratnachudi, IL-23-3	V	Samba Mahsuri, IL-4-5, IL-67-3, IL-69-2, IL-83-6, IL-86-4
		VI	Rasi, IL-1-6, IL-23-3, IL-19-6