

Experimental Investigation of Electric Arc Welding Variables on the Corrosion Behaviour of Steel Welds in Acidic Medium

Abstract

This work investigated the effects of power input and welding speed on the corrosion rate of low carbon steel welds in one molar tetraoxosulphate (VI) acid (H_2SO_4) solution. Locally available low carbon steel rod ($\text{Ø}12\text{mm}$) used for this study was cut into twenty four samples $\text{Ø}12\text{mm} \times 50\text{mm}$ with the aid of hacksaw for both plane face and double V shape. The samples were further processed through machining to get twelve samples for plane face and double-V edge shape respectively. Electric arc welding was used for welding the samples to produce six welded joints for each of plane face and double V shape at different power input and welding speed. Weight loss method was employed to evaluate the corrosion rate of the welded joints in the tested medium. It was discovered from the study that welding speed and power input have significant roles to play in either lowering or increasing the corrosion rate of the low carbon steel welded joints in one molar tetraoxosulphate (VI) acid solution. The plane face and double-V edge low carbon steel welded joints corrodes less at power input and welding speed of 16.5kW and 12cm/min respectively. Their corrosion rate is more aggressive at higher power input and welding speed.

Keywords: Corrosion rate, Low carbon steel, Power input, Tetraoxosulphate (IV) acid, Welding speed.

1. Introduction

Steels are mainly joined by welding process and mostly by arc welding due to its ease to operate and availability. Welding is a most widely used permanent joining process in

pipelines, nuclear power plants, boilers, aircrafts, and rail road equipment construction. A quality weld joint is that which has the properties nearly equivalent to the base metal [1-2]. Welding involves a wide range of scientific variables such as time, temperature, electrode, power input and welding speed.

Many researchers have proved that improper techniques employed in welding may lead to serious consequences of the structures. Asibeluo et. al. [3] studied the effect of current and temperature on mechanical properties of steel welds using shielded metal arc welding process. Investigation was done on a varying range of current. Increase in current resulted to increase in temperature input which affect the microstructure and mechanical properties of the steel weldments [4].

Omiogbemi [5] investigated the effect gas metal arc welding parameters on the mechanical and corrosion behavior of austenitic stainless steel in some environments using design expert software. Gharibshahiyani et. al. [6] investigated that with the increase in voltage, the grain size number decreased in case of low carbon welded steel using inert gas welding.

Afolabi [7] investigated the effects of electric arc welding parameters such as power input, welding speed, weld geometry and post weld heat treatment on the corrosion behavior of austenitic stainless steel in chloride medium. Electrode potential measurement coupled with zinc rod reference electrode was used by him to evaluate the corrosion behavior of his samples. It was found from his work that 3.6kW power input produces the highest resistance weld corrosion while chamfered face edge preparation is the best corrosion resistant sample in the chloride medium.

Olabisi and Akeju [8] investigated the effects of electric arc welding parameters such as welding current and electrode specifications on microstructure and tensile properties of mild steel welded joints. It was discovered from their study that welding at higher current with electrode gauge 12 should be used when ultimate tensile stress is desired in plane face and V-

edge welded joints while that of chamfered face should be done at lower current whenever higher ultimate tensile stress of the welded joints is required.

Salim et. al. [9] studied the effect of welding electrode, welding current and corrosion media on corrosion behavior of three kinds stainless steel (AISI 304, AISI 316 and AISI 410). Their study revealed that increment in heat input by increasing welding current caused reduction in corrosion resistance by facilitating carbon diffusion and formation of chromium carbides in the weld area.

It is therefore of great importance to study the effects of power input and welding speed on the corrosion behavior of steel welds in one molar tetraoxosulphate (VI) acid solution. The results obtained from this investigation are expected to provide more knowledge on the influence of welding variables on the corrosion behavior of steel welded structures during and after fabrication.

2. Materials and Methods

2.1 Materials and Equipment

The materials used for this study include mild steel rod Ø12mm, emery cloth, electrode gauge 12 and one molar tetraoxosulphate (VI) acid solution (H₂SO₄). The equipment used includes electric arc welding machine, measuring cylinders, beakers, vice, hacksaw, digital weighing machine and blower. The chemical analysis of the steel rod was carried out to show its composition and the result is presented in Table 1. The table shows that the rod contains 0.1821% carbon and 98.1339% iron.

Table 1: Chemical Composition of the Low Carbon Steel Steel Used

Elements	Composition (%)	Element	Composition (%)
C	0.1821	As	0.0044
Si	0.2412	W	0.0032
Mn	0.7210	Pb	0.0017

P	0.0341	Sn	0.0428
S	0.0398	Co	0.0095
Cr	0.1082	Al	0.0092
Ni	0.1120	Ca	0.0001
Mo	0.0140	Zn	0.0064
Cu	0.3412	Fe	98.1339
V	0.00165		

2.2 Sample Preparation

Locally available low carbon steel rod ($\text{Ø}12\text{mm}$) used for this study was cut into twenty four samples $\text{Ø}12\text{mm} \times 50\text{mm}$ with the aid of hacksaw for both plane face and double V shape. The samples were further processed through machining to get twelve samples for plane face and double-V edge shape respectively. The samples were cleaned from dirt using emery cloth. Edge preparations were carried out in order to have samples such as double V edge and plane face as shown in Fig. 1 [7]

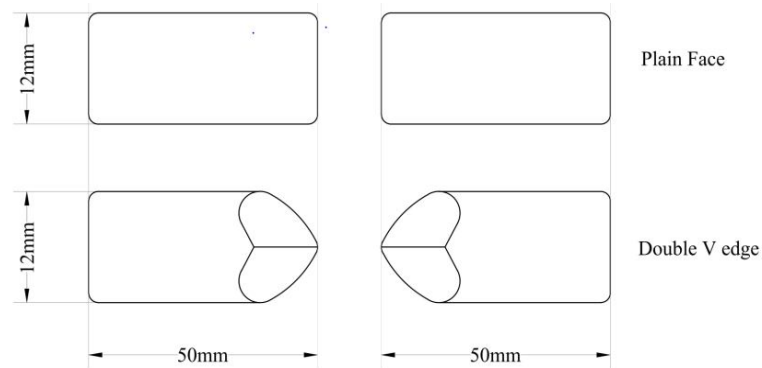

Fig. 1: Shapes of the Low Carbon Steel Welding Samples

2.3 Welding Technique

The welding technique employed in this work is electric arc welding. Electrode gauge 12 was used as welding electrode while the welding current were varied with the voltage fixed at 220V to obtain welding at different power input and welding speed.

2.4 Corrosion Test

The method of corrosion test employed is laboratory test which involves full immersion of the samples and coupons weight loss determination. Weight loss method was used to evaluate the corrosion rate. Weight loss is the measure of difference between the original mass of the sample before immersion (m_1) and the mass of the same sample after immersion and cleaning (m_2). The corrosion rate is calculated in mils per year using the formula given by

$$\text{Corrosion Rate} = \frac{KW}{DAT} \text{ mpy [10]}$$

Where K = 534 (corrosion rate constant), W = weight loss in gram, D = 7.86g/cm³ for mild steel (density of the material), A = total area of exposure = 4cm², T = exposure time in hours, mpy = mils per year (corrosion rate unit)

3. Results and Discussion

The chemical analysis of the steel rod was carried out to show its composition and the result is shown in Table 1. The table shows that the rod is low carbon steel that contains 0.182% carbon and 98.1339% iron.

Tables 2 and 3 show the corrosion rate of the various welded joints obtained by weight loss method at an interval of 120 hours (5 days) and for a period of 840 hours (35 days) of full immersion of each welded joint in tetraoxosulphate (VI) acid solution.

Table 2: Corrosion Rate of Plain Face Welded Samples at Different Power Input and Welding Speed in tetraoxosulphate (VI) acid solution

POWER INPUT/ WELDING SPEED	CORROSION RATE (mpy)						
	120hrs	240hrs	360hrs	480hrs	600hrs	720hrs	840hrs

16.5kW 15cm/min	0.1597	0.1598	0.1598	0.1598	0.1598	0.1598	0.1599
16.5kW 12cm/min	0.1413	0.1415	0.1415	0.1415	0.1415	0.1415	0.1415
16.5kW 10cm/min	0.149	0.149	0.149	0.149	0.1605	0.149	0.149
19.8kW 15cm/min	0.3002	0.3003	0.3004	0.3007	0.3003	0.3005	0.3004
19.8kW 12cm/min	0.1731	0.1731	0.1744	0.1745	0.1747	0.1747	0.1745
19.8kW 10cm/min	0.1995	0.1995	0.1995	0.1995	0.1995	0.1995	0.1997

Table 3: Corrosion Rate of Double-V Edge Welded Samples at Different Power Input and Welding Speed in tetraoxosulphate (VI) acid solution

POWER INPUT/ WELDING SPEED	CORROSION RATE (mpy)						
	120hrs	240hrs	360hrs	480hrs	600hrs	720hrs	840hrs
16.5kW 15cm/min	0.1119	0.1125	0.1127	0.1128	0.1128	0.1128	0.1129
16.5kW 12cm/min	0.0644	0.0644	0.0644	0.0645	0.0645	0.0645	0.0645
16.5kW 10cm/min	0.1245	0.1182	0.1161	0.1151	0.1145	0.1141	0.1138
19.8kW 15cm/min	0.1376	0.1377	0.138	0.1381	0.1381	0.1381	0.1382
19.8kW 12cm/min	0.0914	0.1079	0.1134	0.1162	0.1179	0.119	0.1198
19.8kW 10cm/min	0.1327	0.1328	0.1329	0.1328	0.1328	0.1328	0.1328

Table 4 shows the average corrosion rates of both plane face and double V edge welded joints at different power input and welding speed in tetraoxosulphate (VI) acid solution.

Table 4: Average Corrosion Rates of both Plain Face and Double-V Edge Shape Welded Samples at Different Power Inputs and Welding Speeds in tetraoxosulphate (VI) acid solution

POWER INPUT/ WELDING SPEED	AVERAGE CORROSION RATE (mpy)	
	PLAIN FACE	DOUBLE V EDGE

16.5kW 15cm/min	0.1598	0.1126
16.5kW 12cm/min	0.1415	0.0645
16.5kW 10cm/min	0.1506	0.1166
19.8kW 15cm/min	0.3004	0.138
19.8kW 12cm/min	0.1741	0.1122
19.8kW 10cm/min	0.1995	0.1328

Figures 2 and 3 present further result processing of the corrosion rates of the two considered welding geometries in tetraoxosulphate (VI) acid solution at the various power input and welding speed. Figure 4 gives the average corrosion rates of both welding geometries.

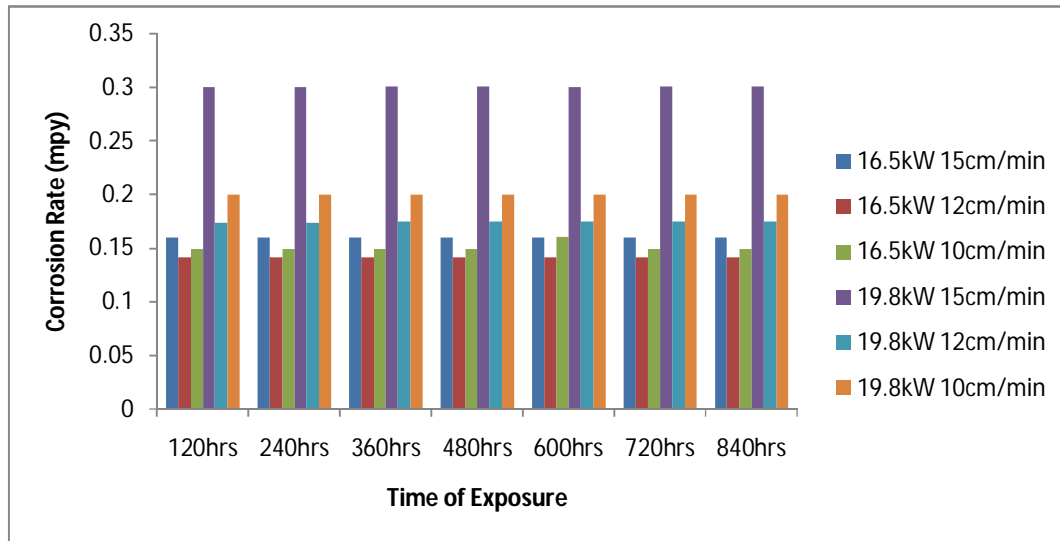

Fig. 2: Corrosion Rate of Plain Face Welded Samples at Different Power Input and Welding Speed in tetraoxosulphate (VI) acid solution

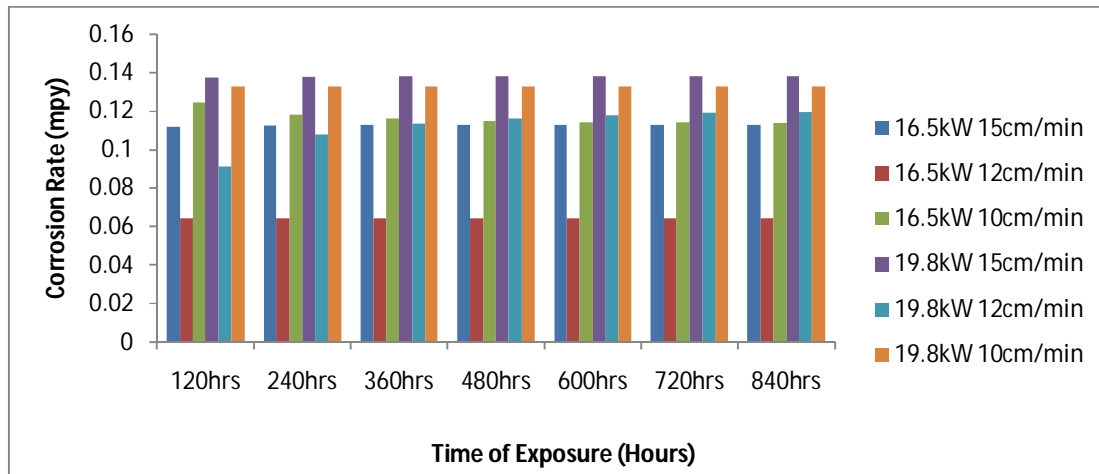

Fig. 3: Corrosion Rate of Double-V Edge Welded Samples at Different Power Input and Welding Speed in tetraoxosulphate (VI) acid solution

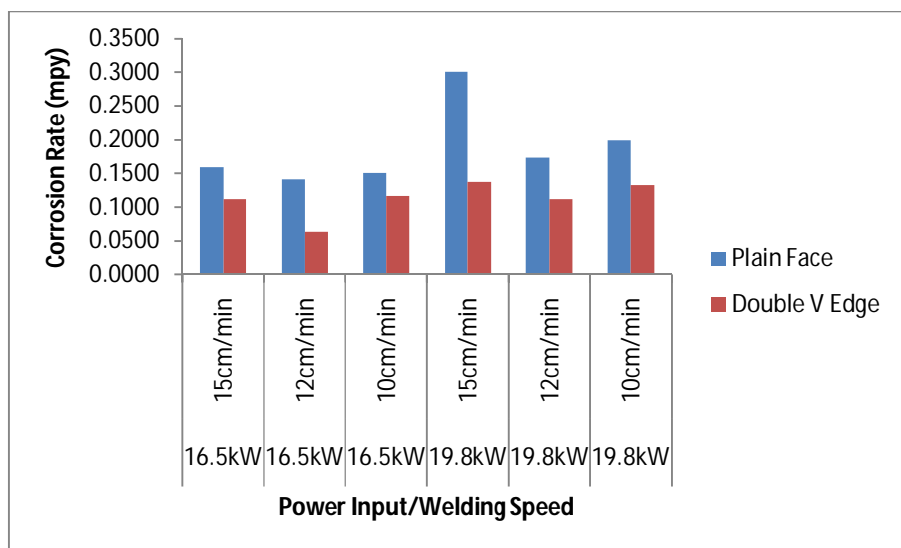

Fig. 4: Average Corrosion Rates of both Plain Face and Double-V Edge Shape Welded Samples at Different Power Inputs and Welding Speeds in H₂SO₄ solution.

It can be deduced from Tables 2 and 4, Figures 2 and 4 that the corrosion rate of the plane face welded joints at 16.5KW power input in conc. H₂SO₄ increases in the order of the welding speed 12cm/min (0.1415mpy) < 10cm/min (0.1506mpy) < 15cm/min (0.1598mpy). This implies that welding the plane face welded joint at medium power input and welding speed of 16.5KW and 12cm/min respectively lowers the corrosion rate of the welded joints.

In addition, tables 3 and 4, figures 3 and 4 also reveal the corrosion rate of double V shape welded joints in conc. H_2SO_4 . The corrosion rate of double V edge welded joint at 16.5KW power input has the least value of 0.0645mpy at the welding speed of 12cm/min. The corrosion rate of the double V welded joint increases in the order of the welding speed 12cm/min (0.0645mpy) < 15cm/min (0.1126mpy) < 10cm/min (0.1166mpy). Welding double V edge joints at medium power input 16.5KW and welding speed 12cm/min lowers the corrosion rate of double V joint than any other welding speed at the same power input.

Welding at higher power input of 19.8KW at all the selected welding speed gives higher corrosion rates than welding at lower power input 16.5KW for both plane face double V welded joints in conc. H_2SO_4 as shown in Tables 2, 3 and 4 and Figures 2, 3 and 4.

Welding current which is a derivative of power input has great influence on corrosion rate. Higher corrosion rate recorded for both plain face and double-V shape welded joints at higher power input 19.8KW shows that corrosion rate increases with increasing welding current [9]. This is also in line with the discussion of Afolabi [7] who discovered that the corrosion rate increases with increase in power inputs while studying the effect of various power inputs on the corrosion behaviour of austenitic stainless steel in sodium chloride.

Table 4 and figure 4 show the effect of the selected welding speed 10cm/min, 12cm/min and 15cm/min on the corrosion rate of both plane face and double-V edge welded joints in the acidic medium. It can be seen that the low and medium speed welded samples displayed the lowest corrosion rate while the high speed welded samples show the highest corrosion rate throughout the exposure period. The speed the electrode travels along the joint has a direct influence on bead shape, depth of fusion, cosmetic appearance and heat input into the base metal [7, 11]

4. Acknowledgments

The authors are greatly indebted to the staff of Welding and Fabrication Unit of the Department of Mechanical Engineering, The Federal Polytechnic, Ado-Ekiti for their technical assistance in the execution of this research work.

5. Conclusion

It can be concluded from the study that:

- Welding variables such as power input, welding speed and welding geometry have a vital role to play in either lowering or increasing the corrosion rate of low carbon steel welded joints in a corrosion medium.
- Plane face and double V edge low carbon steel welded joints corrode less when produced at moderate medium power input and welding speed.
- Plane face and double V edge low carbon steel welded joints corrodes more when formed at higher power input and welding speed.

6. References

- [1] Unnikrishnan, R., Idury KSN, Ismail T.P., Bhadauria A and Shekhawat S.K. Effect of heat input on the microstructure, residual stresses and corrosion resistance of 304L austenitic stainless steel weldments. *Materials characterization* 93, 10 – 23, 2014
- [2] Ogbunnaoffor , C.K., Odo J.U. and Nnuka E.E. The effect of welding current and electrode types on tensile properties of mild steel. *International Journal of scientific & engineering research*, volume 7, issue 5, 2016.
- [3] Asibeluo, I.S. and Emifoniye, E. Effect of arc welding current on the mechanical properties of A 36 carbon steel weld joints. *SSRG International Journal of mechanical engineering*, Volume 2, Issue 9, 2015.

- [4] Widodo E., Iswanto I., Nugraha M. A. and Karyanik K. Electric current effect on mechanical properties of SMAW - 3G on the stainless steel AISI 304. MATEC Web of Conferences 197, 12003, 2018.
- [5] Omiogbemi, M.B. effects of gas metal arc welding parameters on the mechanical and corrosion behavior of austenitic stainless steel in some environments. M.Sc. Thesis, Mechanical Engineering, Ahmadu Bello University, Zaria. May 2015
- [6] Gharibshahiyan E., Honarbakhsh A.R., Parvin N. and Rehimian M. The effect of microstructure on hardness and toughness of low carbon welded steel using inert gas welding. Journal of Material and Design, 2042-48, 2011
- [7] Afolabi, A.S. Effect of electric arc welding parameters on corrosion behavior of austenitic stainless steel in chloride medium. AU J.T. 11(3): 171-180, 2008
- [8] Olabisi, O.I. and Akeju, E.A. The effect of welding current and electrode specifications on microstructure and tensile properties of mild steel welded joints. Global Scientific Journal, 6(9): 878-588, 2018.
- [9] Salim, J.A., Waseem, S.A. and Muhaed, A. Effect of manual arc welding parameters on corrosion behavior of stainless steel. International Journal of Mechanical Engineering and Technology, 10(1): 43-51, 2019
- [10] Ajayi, I.S., Fatona, S.A. and Ojaomo, K.E. Corrosion inhibition of mild steel in hydrogen chloride (HCl) solution using moringa leaf extract. Global Scientific Journal, 8(4): 1216-1229, 2020.
- [11] Lothongkum, G., Viyanit, E., and Bhandhubanyong, P. Study on the effects of pilsed TIG welding parameters on delta-ferrite content, shape factor and bead quality in orbital welding of AISI 316L stainless steel plate. J. Mater. Proc. Technol. 110:233-38, 2001