

AN AUTOMATIC TRAFFIC VIOLATION TICKETING SYSTEM USING RADIO FREQUENCY IDENTIFICATION (RFID) TECHNOLOGY

ABSTRACT

Travel convenience is impacted by a number of factors, including the condition of the road, traffic, length of trip, accidents, speed, etc. The daily increase in accident rates poses the biggest concern. These events not only result in fatalities but also increase the nation's financial losses. Traffic congestion is brought on by road users' lack of discipline and sentiments, which may result in traffic offenses. The goals of this research are to curb any traffic infractions as well as reduce corruption and nepotism on the road. This system was developed using an Atmega328 microcontroller, which instructs the system to identify any driver who violates a traffic light and send an SMS message to the violator and the road management of the violation and the location where it was done. This identification is done with the help of a radio frequency identification (RFID) reader, which gets the unique ID of the vehicle and sends back the information to the microcontroller, which now instructs the GSM module to send the SMS message.

KEYWORDS

Traffic violation, Radio Frequency Identification (RFID) tag, Radio Frequency Identification (RFID) Module, Radio Frequency Identification (RFID) reader, Traffic Signal, GSM Module, Power Supply.

1. INTRODUCTION

Travel is an important part of today's fast-paced life, as everyone has to move around for their day-to-day work. Road transport is the most commonly used mode of travel due to its ease, low cost, and availability to the

common man ^[10]. Worldwide, road traffic injuries claim more than 1.2 million lives each year and are among the leading causes of death among young people. It is estimated that road traffic injuries cost governments approximately 3% of their GDP and up to

5% in low- and middle-income countries. Without action, annual road traffic deaths are predicted to increase to around 1.9 million by 2030 and become the seventh leading cause of death ^[5].

The ease of travel is affected by such factors as the quality of the road, congestion, longer duration, accidents, speed, etc. The major threat is the increasing number of accidents on a daily basis. These accidents not only claim the lives of people but also add to the economic loss of the country. Lack of discipline and emotions among road users cause traffic congestion, which might lead to traffic violations ^[10]. The main types of traffic violations are moving violations and non-moving violations. Driving offenses involving fatalities include dangerous driving and careless or inconsiderate driving. A person drives dangerously when the way they drive falls far below the minimum acceptable standard expected of a competent and careful driver; and it would be obvious to a competent and careful driver that driving in that way would be dangerous ^[9].

2. RELATED WORKS

Radio Frequency Identification (RFID) is an identification technology that utilizes radio waves as a transmission medium, consisting of Radio Frequency Identification

(RFID)tags and Radio Frequency Identification (RFID) readers ^[1]. Each Radio Frequency Identification (RFID) tag has a unique code as an identity that can be read by a Radio Frequency Identification (RFID) reader by sending a request. Radio Frequency Identification (RFID) works at various wavelengths with an area of up to 30 m ^[3]. It can be classified into three categories: passive, active, and semi-passive, with different working frequencies ^[7]. Radio Frequency Identification (RFID) technology has emerged from obscurity and found widespread use in applications that hasten the movement of materials and manufactured items. In contrast to older bar-code technology, Radio Frequency Identification (RFID) permits identification from a distance and does so without having a line of sight. This automated system of Radio Frequency Identification (RFID) will be implemented at each traffic light pole for a red traffic violation, and it will automatically issue a ticket in the form of a short message service (SMS) to the violator and to the road safety management. Traffic light in American Heritage Dictionary, (2016) is a road signal that operates automatically to direct vehicular traffic by means of colored light 'Red' to stop, amber to proceed or go with caution, and 'green'

light to go. This Radio Frequency Identification (RFID) system uses the traffic light mechanism to capture any registered motor user that violates the red traffic light, i.e., any road rider that moves whenever the 'red' light is initiated. A message will be issued as a ticket to the violators and as information to the road safety management. The ticket may constitute a notice that a penalty, such as a fine or deduction of points, has been or will be assessed against the driver or owner of a vehicle for a violation, failure to pay generally leads to prosecution or civil recovery proceedings for the fine ^[4].

In the ^[6], Radio Frequency Identification (RFID) reader is an intelligence system used for identification of vehicles on the road, The Radio Frequency Identification (RFID) reader is placed on the surface of the road, so when a vehicle crosses it, it, it will immediately pick the unique ID of the vehicle.

^[2] used GPS to obtain details about the location and speed of the vehicle. A traffic violation warning and storage device is built into the car, and it can also be used to store the map data, the rules of the road, and any infractions the driver has committed. To handle and control the device's various units, a controller was released. To ascertain

whether a violation has occurred, the GPS data is compared with previously saved map data and traffic regulations. Depending on the outcome, the motorist may receive a warning if a potential violation is identified or a ticket may be recorded in the device's violation memory if a violation has been committed. Furthermore, to save encrypted tickets in the memory, an encryption mechanism is also offered. On the management display, you may later check the issued tickets as well as the specifics of the violations and personal data.

^[13] presented an intelligent traffic management expert system using Radio Frequency Identification (RFID) technology for data gathering and control information that can track criminal or unlawful vehicles like stolen cars or vehicles that avoid paying fines, tolls, or vehicle taxes. To collect traffic data, regulate traffic, find the shortest routes, and track down unlawful vehicles, a passive Radio Frequency Identification (RFID) reader and tags were employed in this study. to reduce traffic offenses, lower costs, and delay travel time when entering and departing highways. ^[8] presented an intelligent highway system that offers assistance to drivers of moving vehicles on the highway, detects improper parking, including in no parking, accident, or stop

zones, and also detects overspeeding or lane changes. The software sent a warning signal to the patrol cop after receiving a signal from the reader in the intelligent light pole or forwards multiple signals to subsequently emergency vehicles or to nearby police if the parking violation is on. The Radio Frequency Identification (RFID) reader is installed in the intelligent light pole, powered by solar cells, which covered the highway in the shape of every third pole. the main lines of the road, and last but not least, the reverse light pole number that appears on the tag; if the car is traveling in the incorrect lane, the Radio Frequency Identification (RFID) reader sends the tag data to the main computer.

^[12]utilized Radio Frequency Identification (RFID) Technology to suggest a redesigned automated ticketing system that is more effective and improved. The paper's main goal is to evaluate and circumvent its limitations in order to increase the effectiveness of the already recommended Radio Frequency Identification (RFID) ticketing system. To make distance calculations easier, the current approach suggests installing Radio Frequency Identification (RFID) reader circuit in each and every bus stop. This paper proposes the implementation of the ticketing system

using a cyclometer, which may be connected to the bus' wheel or wheels to measure the precise distance travelled by the user, while taking into account the cost and complexity (read automobiles). The corresponding cost is automatically subtracted from the user's account based on the distance traveled. An automated database system is used to carry out the work, which speeds up, simplifies, and eliminates ambiguity in all interactions.

^[8]Proposes an approach for Radio Frequency Identification (RFID) Ticketing used for Personal Navigator for a Public Transport System which is based on ticketing and identification of the passenger in the public transport. There are several security issues as well as a serious malfunction of public transportation in large cities like Mumbai and Kolkata. Three modules make up the overall network: the base station module, the in-bus module, and the bus stop module. Two Microcontrollers, a GSM Modem, GPS, Zigbee, Radio Frequency Identification (RFID), LCD, and an infrared sensor are included in the In-Bus Modules. Radio Frequency Identification (RFID) for ticketing purpose. In order to communicate information about buses to bus stops and from bus stops to buses, the microcontroller and Zigbee module are also interfaced. The Bus Stop Module, which is

permanently installed at each bus stop, consists of a Zigbee node connected to a microcontroller.

^[11]proposed a system that helps conductor in transport fare collection called Automatic Fare Collection System implemented using Radio Frequency Identification (RFID) /Smart card. Radio Frequency Identification (RFID) card is given to the passenger and when gets into the bus he has to swipe the card in the Radio Frequency Identification (RFID) reader and has his destination point in the device, which would automatically calculate the fare and

3. MATERIALS AND METHODS

3.1 System Design

The automated traffic violation ticketing system using radio frequency identification technology (RFID) consists of different units, which include a microcontroller unit, a radio frequency identification technology (RFID) unit, and a communication unit using GSM. The Radio Frequency Identification (RFID) tag is attached to the user's car. The Radio Frequency Identification (RFID) reader then reads the RFID tag attached to the car. The Radio Frequency Identification (RFID) reader will

deduct the money automatically. Conductor also feels free and more organized in the money from the people. All the record will update automatically in the server continuously when more people are travelling, and easy issuing of the ticket. A based webpage monitors the bus for amount, path taken, bus status number of passengers, and distance information. It fixes every issue with the IOT-based web page monitor system in buses. Index Terms: Radio Frequency Identification, Internet of Things (IOT), and Network Security (RFID).

give a beep sound whenever a Radio Frequency Identification (RFID) tag is at the same frequency with the Radio Frequency Identification (RFID) reader (i.e. the Radio Frequency Identification (RFID) tag is within the range at which communication can be established between the Radio Frequency Identification (RFID) reader and the Radio Frequency Identification (RFID) tag when the user pass the traffic light whenever the red light is high thereby sending data to the GSM module through the microcontroller and issue ticket to the road user violator registered number informing road user violator about the violation and the fine to pay and also to the road safety admin.

The system design consists of hardware design and software design, implemented together to achieve this project. Figure 1 depicts the block diagram of the system. The system has several hardware components, such as the ATMEGA328 microcontroller, Radio Frequency Identification (RFID) tag, Radio Frequency Identification (RFID) reader, GMS module (SIM 800), relay, power supply unit, jumper wire, traffic light, and some other electronic or electrical components. The software consists of code that would be compiled on

the Arduino IDE and embedded into the microcontroller; it would be a part of the hardware design. The design and construction of an automated traffic violation ticketing system using radio frequency identification technology (RFID) was designed to overcome the issue of accidents. Corruption and nepotism on the part of road safety agencies Intensive stress on the part of the road safety officer on duty, deviation from traffic rules by road users by not violating the traffic light rule.

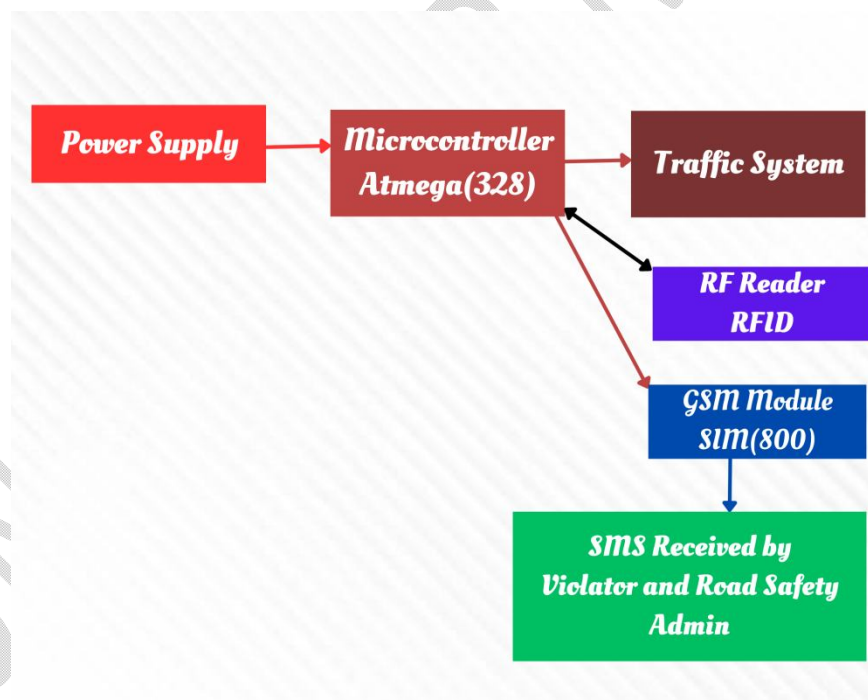

Figure. 1. Block Diagram of an Automated Ticketing System

3.2 Power Supply Unit

This unit was designed to supply DC voltage and current to the whole circuit, as shown in

Figure 2. In order to build this power supply, a step-down transformer is used to reduce the input voltage from 220 VAC to 12 VAC.

A full-wave bridge rectifier is then used to rectify the voltage, turning 12 VAC into 12 VDC. Finally, a capacitor is used to filter out any pulsating AC voltage that wasn't completely converted. The power supply is connected to the outlet socket on the wall, supplying unregulated AC voltage, and the output pin is connected to the input pin (V_{in}) of the voltage regulator. The regulator

modulates and regulates the 12VDC to give a constant regulated 5VDC needed by the controller and provide the other electrical and electronic components used in the circuit designed their exact standard operating voltage. However, this was done to prevent damage to the microcontroller ICs and other components from excess supplied voltage.

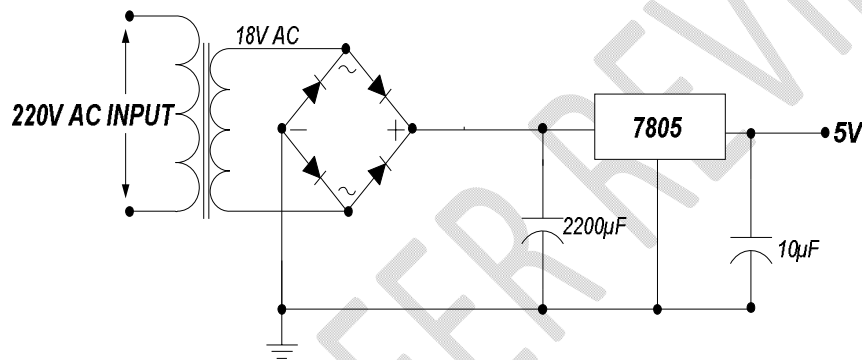

Figure. 2. Regulated power supply

3.3 Microcontroller Unit

This is a unit that works like a compressed micro-computer, programmed with C language to control and manage the functions of the embedded system. The factors considered when choosing our microcontroller are:

- The number of digital inputs and output pins. The system concerned requires a microcontroller with large pin counts.

- The size of the program memory storage required.
- The magnitude of clock frequency; a factor which decides the execution rate of task of the microcontroller.
- The number of interrupts and timer circuits required i.e no of additional ICs required. ATMEGA328P is the type of 8-bits AVR microcontroller based on the advanced reduced instruction set computer (RISC) architecture. It is low power CMOS

technology based controller due to its architecture it can execute millions of instructions in a seconds, if cycle frequency is 1MHz provided by crystal oscillator.

Some of the internal and external features of this controller are 2kilo bytes of internal static RAM, 32x8 general working purpose registers, 28 pins dual-in-line package, 23 programmable I/O lines pins, programmable serial USART, 1024 bytes EEPROM. EEPROM is normally used to store coded data that needs to be saved over a long period over many power-up and power off cycles. This memory is nonvolatile, which means that it will retain its data, even if the power is lost. In this design this EEPROM is used to store codes written to control the traffic system and the Radio Frequency Identification (RFID) operation. It was inserted into its socket already soldered on the Uno board, out of its 28 pins, the pin1 known as reset pin is attached to a Pull up resistor (linked with Vcc) which keeps the reset button high for the microcontroller to operates smoothly. The value of pull up resistor was calculated using the

$$\text{Ohms law } V = IR. \quad (3.1)$$

$$v = I \times R$$

The voltage of the microcontroller (Vcc) is 5V and the current through is 1mA

$$\text{Resistor value}_{(\text{pull-up})} = \frac{V_{cc}}{\text{Current through}} \quad (3.2)$$

$$= \frac{5.00V}{0.001A} \\ = 5k\Omega$$

However, the value of pull up resistor used for the reset button was not exact 5k Ω but 10k Ω , it was advisable not to use the exact value to avoid damage due to excess current. A computer serial port (USART), GSM module (SIM 800) and Radio Frequency Identification (RFID) connector were connected to the TX pin to transmit signal (such as written program) to the microcontroller and RX to receive signal from the microcontroller, pin 7 and pin 20 were connected to Vcc and pin 8 and pin 22 were grounded, thus 0.1 μ F coupling capacitor was placed near VCC and GND to prevent noise entering the controller IC, the remaining digital input pins: 3, 4, 5, 6, 11, 12, 13, 14 and 15 were connected to the nine LED terminals used for T-junction traffic light system.

3.4 TRAFFIC SYSTEM

This unit was responsible for the controlling of traffic of the t – junction road,

using three-sided traffic light system. The unit was designed using nine different LED connected to the microcontroller with resistor to control the current flowing through the LED, to prevent damage of the LED. The value of the resistor used was obtained by using this formula.

The battery voltage – the voltage drop of the LED

The current of the LED.

The voltage drop of the LED is 1.7V and current is 10mA

$$\text{Resistor value} = \frac{5V - 1.7V}{10 \times 10^{-3}} = \frac{3.3}{10^{-2}} = 330 \Omega$$

Hence a resistor of 330ohms was connected to the LED to prevent damage by current Each side of the traffic light system used three LED of different colors (green, amber,

3.5 RF READERRadio Frequency Identification (RFID) (RC522)

This unit, radio frequency identification, describes the system in which the identity of an object is communicated through radio waves from the tag to the reader. Radio Frequency Identification (RFID) used is RF522 with the following considerations: low power consumption, low cost, pretty rugged in any form of weather condition, and easy interface with the microcontroller

red). These LEDs are programmed, using C programming language, to operate exactly like a real traffic light system. Whenever the green LED on side 1 of the traffic light is High, the red LED of the other two sides must be high indicating that only a road out of the three roads is allow to traffic for 60seconds, then the amber LED is high for side1 and side 2 for 5 seconds indicating that road1 traffic is ready to stop and road 2 traffic is ready to go, then the side 2 green LED is high this makes side1 and side3 red LED high, indicating movement alone in side 2 for 60 seconds. The amber LED of side2 and 3 turn high for 5 seconds then the green LED of side3 turn high and movement is allowed. NE555 timer was connected to microcontroller to control the timing of the traffic light.

for transmission of signals using UART communication. The Radio Frequency Identification (RFID) reader and its pins are connected to the Uno board. The Radio Frequency Identification (RFID) 522 Reader Module was directly interfaced with 5V ATMEGA 328P microcontrollers on the Uno board. A Radio Frequency Identification (RFID) tag is brought into the field of the Radio Frequency Identification (RFID) Reader to check for functionality,

i.e., if reader and tag can both communicate successfully, it will read its tag number and give output via the TX terminal to the controller.

3.6 GSM module (SIM800)

This unit was responsible for issuing tickets. It serves as a Radio Frequency Identification (RFID) communication channel. The SIM800 is a cellular communication module with an 850 MHz frequency that can make calls, send email and SMS texts, and even connect to the internet. Its extensive features include a portable size, an affordable module, a micro SIM card interface, in-built GPS, and 8 external pins and a UART.

3.7 SMS Message

When a violation occurs, this technology helps send a message directly to the mobile device of the violator right after the violation. The decided SMS message for violation is sent to the violator's registered mobile number, which includes the fine to be charged.

3.8 Principle of Operation

If the system is connected to a 240V AC power supply and powered on, the traffic light, radio frequency technology (RFID), and GSM module (SIM800) are automatically switched on. Once a vehicle moves across the radio frequency technology when the traffic light is red,

which indicates stop, the microcontroller quickly triggers the GSM module (SIM800) to send an SMS message to the road violator and road safety management informing them about the road violator. The message issued to the violators entails the fee to be paid and the deadline for the payment, and that of the management. If the violator refuses to pay or keeps violating. This system design for this work is depicted in the flowchart. The flowchart shows the diagrammatical stepwise algorithm that illustrates the operating principle of the programmed automated traffic violation ticketing system using radio frequency identification technology (RFID). The cycle starts by checking the state of the traffic light. If green, the car should initiate movement; if amber, it should stop or move; if red, the car should stop. For any detected movement, the reader should read the information on the tag of the registered violator, relay the information to the Radio Frequency Identification (RFID) microcontroller, which will initiate the GSM module (SIM 800) to issue a ticket to the violator via SMS, and then send information about the violation to the road safety administration for management. And the circuit diagram shown below helps give a clear view of the components used during the construction of

the work as well as some of the extracted code used to develop the project, which was done with Arduino C Language.

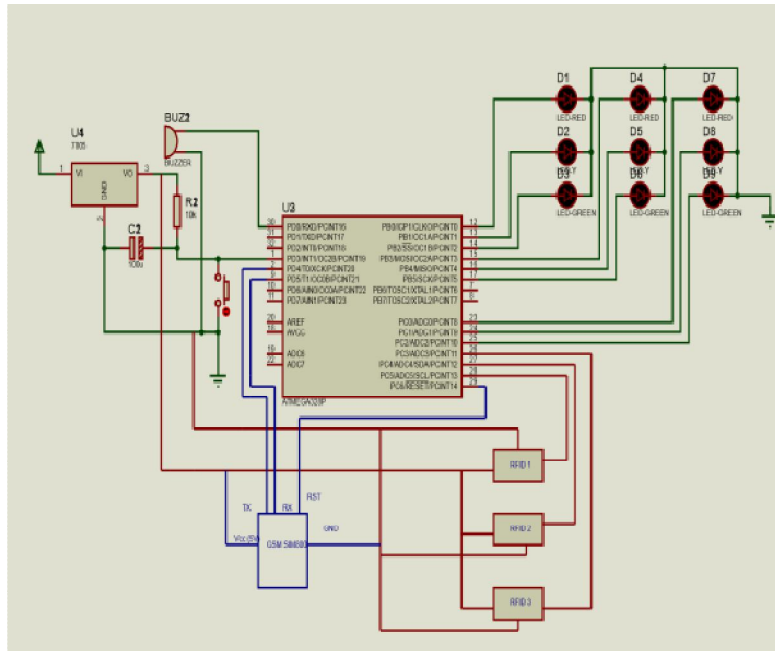

Figure. 3. The Circuit Diagram of an Automated Ticketing System using Radio Frequency Identification (RFID)

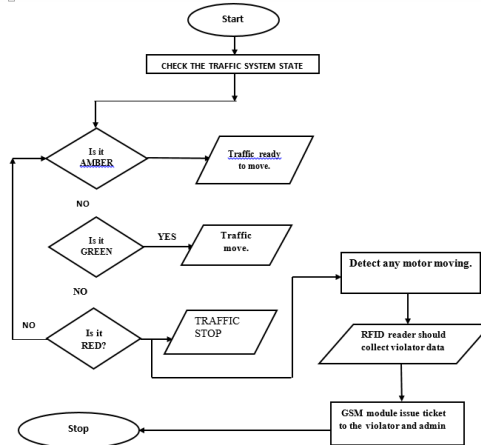

Figure. 4. System Flowchart

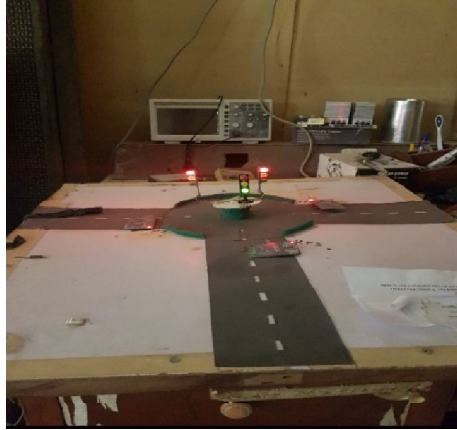

Figure. 6. Testing of the whole circuit.

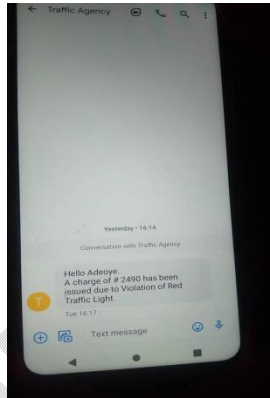

Figure. 7. Ticket received by violator.

5. CONCLUSION

The work was accomplished by developing a T-junction light model that reduces the rate at which road users violate traffic lights. This model helps in the immediate identification of road violators through the registered Radio Frequency Identification (RFID) tag placed under the vehicle. If any model vehicle passes over the Radio Frequency Identification (RFID) reader whenever the traffic light is red, which

indicates stop, the GSM module sends an SMS message to the violator's mobile device informing the user about the violation and the fine to be paid. As stated in the specific objective of the project, a critical design was done to drastically reduce the stress undergone by traffic officers. Therefore, the implementation of this automated ticketing system with a little improvement on its limits will go a long way in ensuring improved technology in the area of

trafficsafety and security, especially in developing countries.

REFERENCES

1. Banu, S., and Marti, W. S. (2021). Developing parking queue monitoring system using Wireless Sensor Network and Radio Frequency Identification (RFID) technology. *Journal of Physics: Conference Series*, 1-10.
2. Douglas, D. (1960). History of Law. Retrieved from Healing Law: <https://healinglaw.com/blog/the-history-of-driving-laws-1901-1960>
3. Fabien, B., Carole, G., Nathalie, G., and Brice, S. (2017). "A review: Radio Frequency Identification (RFID) technology having sensing aptitudes for food industry and their contribution to tracking and monitoring of food products". *Trends in Food Science and Technology*, 62, 91-103.
4. Larson, Aaron. (2016). *HYPERLINK* https://www.expertlaw.com/library/traffic_tickets/fighting_tickets.html "Should You
5. Mahesh, M., and Naman, M. (2020). Automated Traffic Regulation using Radio Frequency Identification and Geo-Fencing. *International Research Journal of Engineering and Technology (IRJET)*, 07(06), 3318-3322.
6. Makanjuola, P. O., Shokenu, E. S., Araromi, H. O., Idowu, P. O., & Babatunde, J. D. (2022). An Radio Frequency Identification (RFID)-Based Access Control System Using Electromagnetic Door Lock and an Intruder Alert System. *Journal of Engineering Research and Reports*, 22(11), 7-17.
7. Roberts, C. M. (2006). Radio Frequency Identification (RFID). *Computers and Security*, 25(1), 18-26. doi:10.1016/j.cose.2005.12.003
8. ThimmarajaYadava G, PremNarayankar, Beeresh H V. (2014), "An Approach for Radio Frequency Identification (RFID) Ticketing used for Personal Navigator for a Public Transport System," *International Journal of Technical Research and Applications*, 2(3), pp. 109-112.
9. Sahar, H., Mehrdad, J., Seyyed, M. H., and Peyman, P. (2012). Traffic Violation Detection System Based on Radio Frequency Identification (RFID). *International Journal of Science and Engineering Investigations*, 1(11), 60-64. Retrieved from www.IJSEI.com
10. Saritha, M., Rajalakshmi, S., Angel, D. S., and Milton, R. S. (2018). Radio Frequency Identification (RFID)-Based Traffic Violation Detection and Traffic Flow Analysis System. *International Journal of Pure and Applied Mathematics*, 118(20), 319-328. Retrieved from <http://www.ijpam.eu>
11. Sunitha, N. A., Sangeetha, G., and Vidya, J. J. (2017). Automatic Bus Fare Collection System using Radio Frequency Identification (RFID). *International Journal of Advanced Research in Computer*

12. Varun Krishna K.G., Selvarathinam S., Roopsai V., Ram Kumar R.M. (2013), "Modified Ticketing System using Radio Frequency Identification (RFID)," *International Journal of Advanced Computer Research*, 2(3), 12. 109-112.
13. Wen, W. (2010). An intelligent traffic management expert system with Radio Frequency Identification (RFID) technology. *Expert Systems with Applications*, 37(4), 3024–3035. <https://doi.org/10.1016/j.eswa.2009.09.030>

UNDER PEER REVIEW