

PERFORMANCE ANALYSIS OF PV/T MODULES IN WEST AFRICAN CLIMATE ZONES

ABSTRACT

The use of solar photovoltaic (PV) panels has been seen as a viable solution to improve the rate of rural electricity supply in African states. Today, the use of solar PV systems has helped to overcome low electricity coverage rates. One of the bottlenecks of PV installations in sub-Saharan Africa is the low efficiency of solar PV modules caused largely by heat accumulation during system operation. This research work aims at studying the electrical performances of PV and PVT modules, in the different climatic zones of West Africa, in order to characterize and promote them in rural sanitary areas for the simultaneous production of hot water and electricity. The meteorological data used are of TMY type and come from the PVGIS site. The simulation of the operation of the different PV module technologies implemented in the Simulink/Simscape environment of Matlab R2021a allowed to estimate the LCOE values, over a typical year, with the different meteorological data of the studied climatic zones. The results obtained show that PVT modules offer LCOE gains ranging from 2% to 12% compared to conventional PV modules. The highest performances are obtained in the Sudanian and Sudan-Sahelian climatic zones, while the Guinean zone shows the lowest gain.

Keywords: PV and PVT modules, weather data, simulation, power generation, LCOE

1. INTRODUCTION

The production of energy to satisfy the needs, remains a universal challenge for the whole world. Most of the world's energy is produced from fossil deposits (oil, gas, coal . . .)[1]. The exploitation of these energy sources has led to extreme climatic upheavals in recent years. To avoid the worst, attention is increasingly focused on renewable energies such as: hydraulic, solar thermal, wind, biomass and solar photovoltaic. Of all these sources, solar energy has a huge potential and is well distributed in Sub-Saharan Africa. However, the share of photovoltaic solar energy in the production of electricity is still modest because of its intermittency and its low electrical efficiency due mainly to the accumulation of heat during its operation [2].

Nowadays, there are PVT modules with the ability to simultaneously produce heat energy by heat transfer fluids and electrical energy with higher efficiency [3]. Aware of the influences of weather data on solar collectors and the naturally more expensive cost of PVT technology, several studies have been devoted to the technical-economic interest of its deployment in different climatic zones.

In Ghana's hot and humid tropical climate in 2019, the study comparing the energy performance of a photovoltaic-thermal (PVT) module versus a conventional photovoltaic (PV) module over one year reveals average electrical/thermal efficiencies of 56.1% for PVT and 12.7% for PV [4]. The one conducted in 2021 by the analytical models on the techno-economic viability of PVT and monocrystalline silicon PV modules over 25 years in Ghana, shows that the PVT system generally performs better than the conventional PV system when both systems are installed with batteries, although the PVT system is more expensive.

Without batteries, the study shows that the conventional PV system becomes more economically viable than PVT [5].

Slimani et al., [6] conducted in 2017, a comparative performance study of four solar module configurations: photovoltaic module (PV-I), conventional air hybrid solar collector (PV/T-II), glazed air hybrid solar collector (PV/T-III), and glazed collector, dual pass air hybrid solar collector (PV/T-IV). A numerical model has been developed and validated with experimental results. The model is used with a sample of meteorological data from the Algiers site. The numerical results show that the daily average of the overall energy efficiency reaches: 29.63%, 51.02%, 69.47% and 74% for the first (PV-I), second (PV/T-II), third (PV/T -III) and fourth (PV/T-IV) module respectively. These values are obtained with an air flow rate of 0.023 kg/s and by introducing a sample of experimental meteorological data collected at the Algiers site for a sunny day in summer.

Kulkarni et al., [7] installed in 2020, photovoltaic-thermal (PVT) modules to provide both electricity and heat extracted by a given water circuit. The study compared the performance of a normal PV module to the new PVT module. The PVT system is manufactured and experiments are conducted to evaluate the electrical and thermal efficiencies. An improvement of 2.17% was observed in the electrical efficiency of the PVT module compared to the normal PV module.

Mansouri et al., [8] presented in 2019, a theoretical study on a PV/T fluid bi-collector module. A numerical model was developed and simulated in MATLAB. A comparative analysis between a conventional water-based PV/T module and another bi-fluid (water/air-based) module, namely PV/Tb, is presented for winter and summer days. For the winter day studied, the numerical results show an overall performance improvement of the bi-fluid PV/T module, with an increase in thermal energy transferred to the liquid side of 20%, and 15.3% for the overall energy efficiency compared to the conventional PV/T collector. No performance improvement was observed during the summer day.

As shown in previous work, the performance of PVT modules varies from region to region. This study aims to investigate the potential value of PVT modules in West African climatic zones.

2. METHODOLOGICAL APPROACH

The methodology adopted is divided into three main steps, described below:

- **Step 1 - Definition of a daily energy requirement:** For simulation purposes, a single daily load profile (same energy requirement) is defined for all climate zones. On the one hand, it is a daily electrical energy requirement noted E_{jel} and on the other hand, a daily thermal energy requirement E_{jth} .
- **Step 2- Sizing the PV or PV/T solar array:** For each climate zone, the energy need E_{jel} is used with the corresponding meteorological data to size the PV field to meet the said need. The power of the PV or PVT field is given by the following formula:

$$P_c (Wc) = \frac{E_{jel}}{H \times PR} \quad (1)$$

With H (kWh/m² /d), the minimum value over the year of the monthly averages of the daily irradiation of the considered site. PR, the performance ratio which integrates the efficiency of the modules and the various losses (cables, dust etc.)

In each of the climatic zones, the simulations will be done with PV and PVT fields of the same peak power equal to P_c .

- Step 3- Simulation of the PV or PV/T solar array:** the previously dimensioned PV and PVT solar arrays are simulated in grid-connected solar systems (without storage). The mathematical models used for both types of modules (PV or PVT) have been experimentally validated in other works. The model used for conventional PV modules has been developed and experimentally validated by one of the authors of this paper [9], [10]. The second model used for the PV/T modules is part of the built-in library of the MATLAB R2021a Simscape environment. However, two modifications were made to the Simscape block model. First, the Simscape model has been modified so that it can also simulate variable loads. The second modification of the Simscape model made it possible to simulate PV fields of different powers. The two models thus obtained were embedded in Simulink diagrams and used to simulate PV and/or PVT modules in different climate zones.

The following figure shows the Simulink model with the two blocks described above.

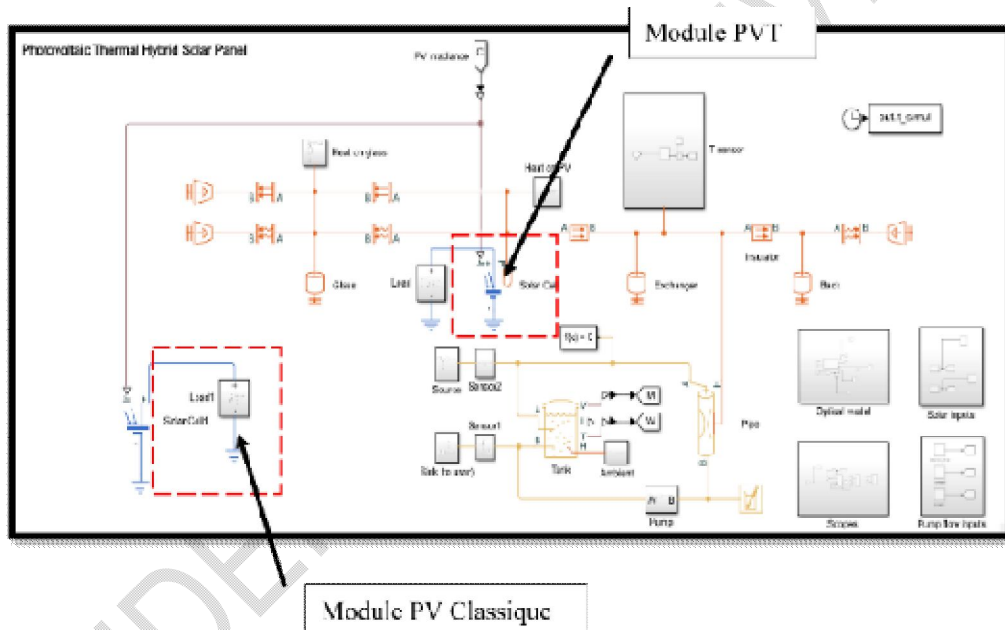

Figure 1 Simulink/Simscape block for simulation of PVT and/or PV module behavior in the Matlab 2021a environment

- Calculation of the performance indicators of the simulated systems:** The outputs of the models are among others: the useful energy produced by the conventional and thermal PV systems. These data are used to calculate one of the best performance indicators of PV systems: LCOE (Levelized Cost Of Energy). It is given by the following formula and defined elsewhere [11] [11]:

$$LCOE = \frac{LCC}{Q * \sum_{t=1}^N \frac{1}{(1 + a)^t}} \quad (2)$$

With

- LCC: life cycle cost of the project, discounted to year 0.
- a : The discount rate
- N : the life of the project in years ;
- Q : Energy generated over period N in kWh.

The total LCC cost is given by the following formula:

$$LCC = I_0 + M + R + Cst (C_R - d_m) \quad (3)$$

With :

- I_0 : Initial investment
- M : Maintenance costs for cleaning photovoltaic panels
- R : Replacement cost of the main equipment
- C_R : Residual cost of main equipment
- Cst : Binary parameter allowing to integrate or not the C_R and d_m
- d_m : dismantling cost

3. RESULTS AND DISCUSSION

3.1 Areas of influence and weather conditions

The figure below shows the five climate zones of West Africa.

These are: (1) Bouake in Côte d'Ivoire, Guinean zone; (2) Kandi in Benin, Sudanian zone; (3) Ouagadougou, in Burkina Faso in the Sudano-Sahelian zone; (4) Bilma in Niger, Sahelian zone; and (5) Kidal in Mali in the Saharan zone. As shown in the figure, a representative locality was chosen in each of the climatic zones.

The TMY weather data for the five selected locations are obtained from the PVGIS website.

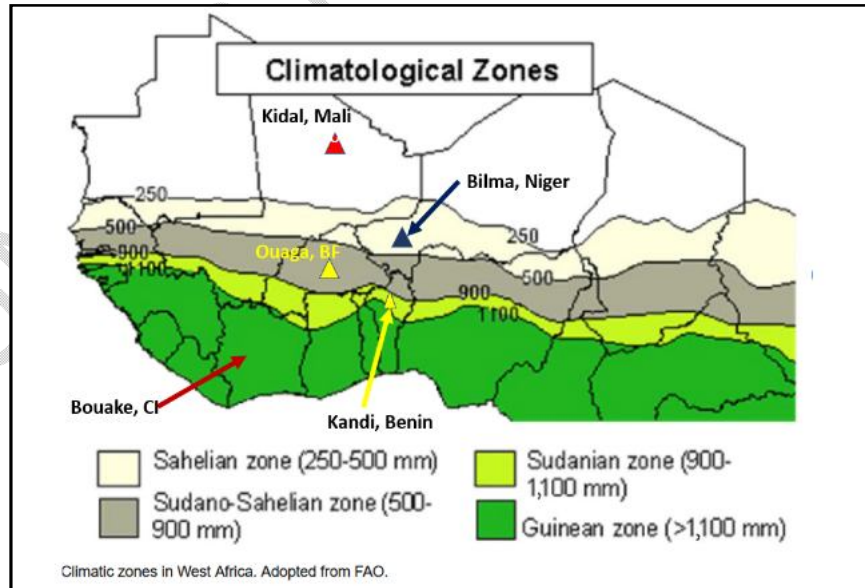

Figure 2 The five climate zones of West Africa [12]

The figures below show the weather data (irradiance and ambient temperature) in the five climate zones.

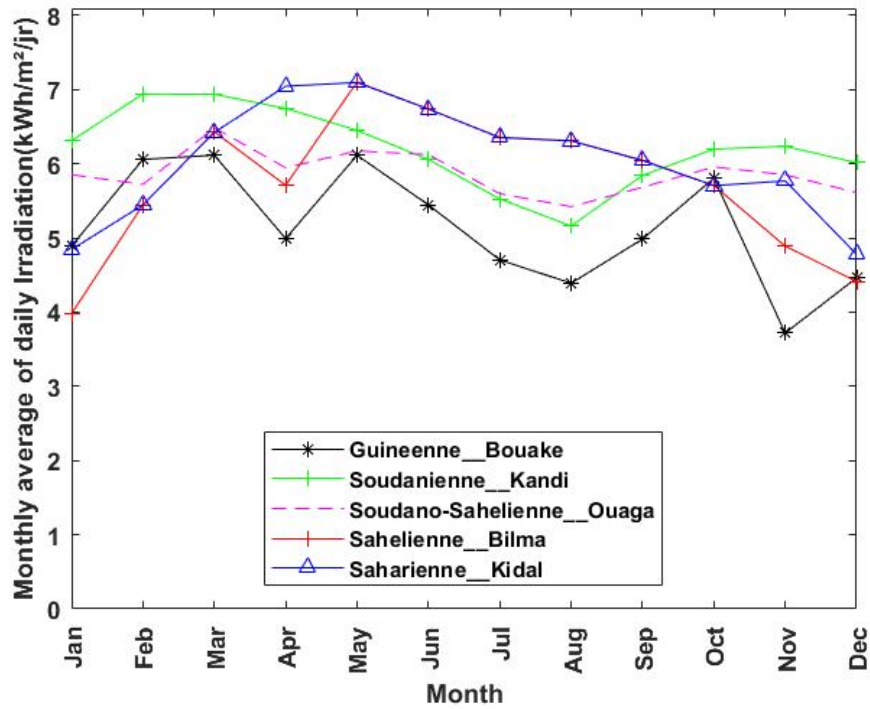

Figure 3 Monthly average daily irradiance (kWh/m² /d) in the five different climatic zones of West Africa

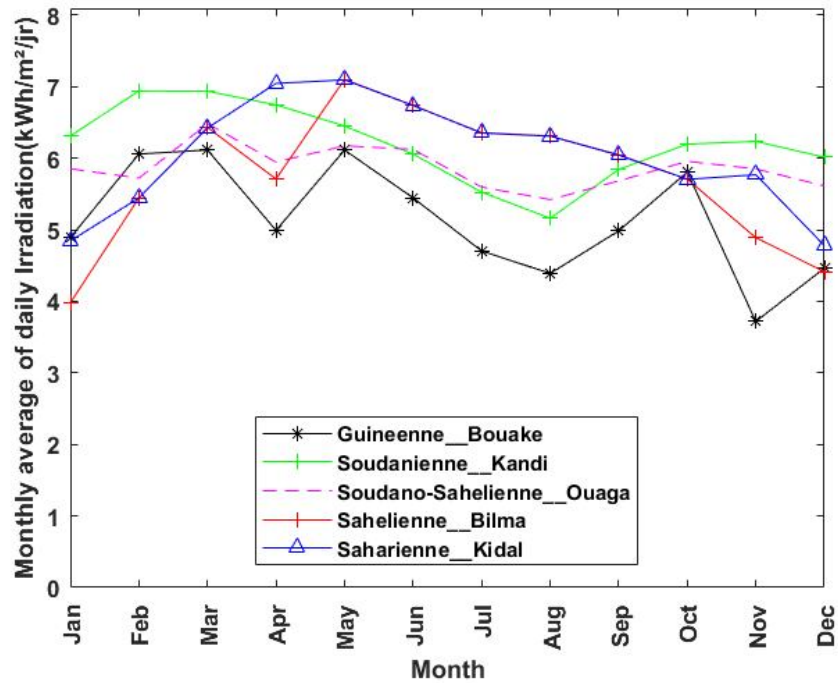

Figure 4 Monthly average ambient temperature in the five different climatic zones of West Africa

3.2 Daily balance of electrical and thermal energy

For the purposes of this study, research was conducted in some health centers and in feasibility study reports for electrification in rural areas in some countries such as Benin. A typical daily load profile for both the electrical and thermal energy needs of a typical health center emerged. The figures below show the different load profiles.

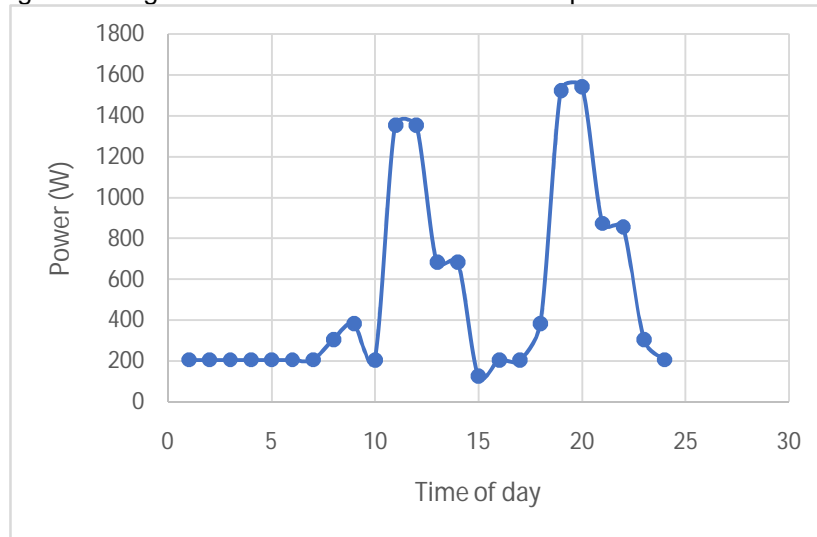

Figure 5 Daily electricity load profile.

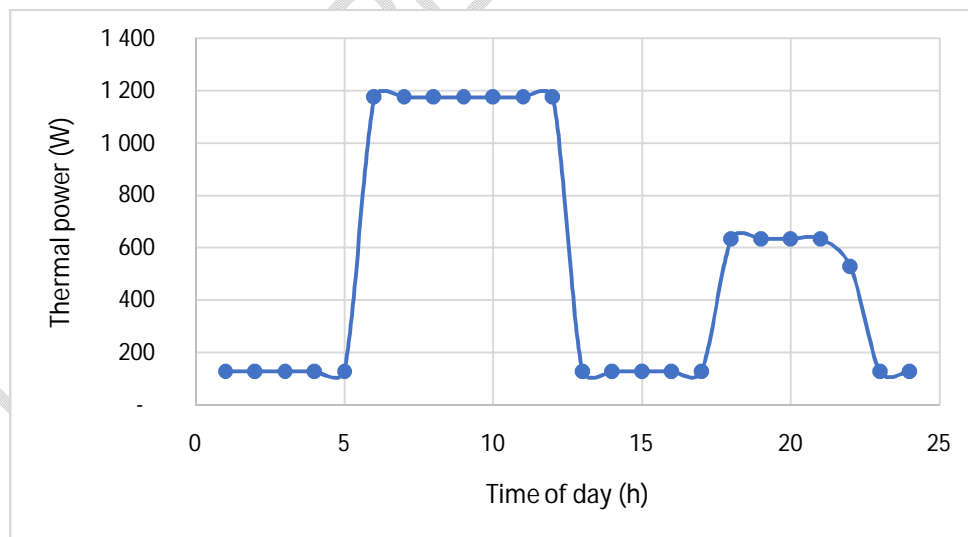

Figure 6 Daily thermal load profile

The total daily requirement is 25316 Wh/d. The profiles are selected to have the same thermal and electrical requirements of 12,658 kWh/d.

3.2 Sizing of PV or PVT systems

For the comparison purposes required by this study, the modules chosen are all monocrystalline technologies and have the same 300 Wp peak power. The table below presents the main characteristics of the two modules.

Table 1. Main characteristics of the selected modules (PV and PVT)

References	Dualsun 300 Black	SPM 033002400
PV technology	Monocrystalline	Monocrystalline
Number of cells	60	60
Cell area (m) ²	0,02725	0,0269
Short circuit current I _{cc} [A]	9,77	8,56
Open circuit voltage [V].	39,9	45,5
Nominal power (Wp)	300	300
Voltage (V) at rated power (V _{mpp})	32,6	36
Current (A) at rated power (I _{mpp})	9,19	8,33
Temperature coefficient Voltage (%/°K)	-0,29	+0,037
Temperature coefficient Current (%/°K)	0,05	0,037
Temperature coefficient Power (%/°K)	-0,39	-0,48

The table below shows the main data used as inputs and the design results obtained in each of the climate zones.

Table 2. PV field sizing results for the five West African climate zones

	Zone Guinean woman	Sudanian zone	Sudano-Sahelian zone	Sahelian zone	Saharan zone
Daily energy E_{jel} (kWh/d)			12,658		
Daily irradiation (kWh/d/m) ²	3,72	5,16	5,42	3,98	4,77
Minimum peak power (kWp)	4,86	3,50	3,34	4,54	3,78
Number of PV or PVT modules	17	12	12	16	13

In view of the irradiances and the dimensioning results, it would seem that the most favourable zones for photovoltaic are the Sudanian and Sudano-Sahelian zones.

The table below shows the cross-performance of PV and PVT systems in the five climate zones. In general, we note that solar modules (PVT or not) do not have the same performance from one zone to another.

However, PVT modules always provide better performance. The gains obtained in terms of LCOE vary from 2% to 12%.

The smallest gains are obtained in the Guinean zone. Knowing for example that the city of Cotonou belongs to the Guinean zone, we can estimate that the two types of modules are equivalent there. On the other hand, the results show a substantial interest in deploying PVT modules in the other climatic zones of Benin (Sudan and Sudan-Sahel),

Table 3. Performance of PVT modules in different climatic zones of West Africa

Climate zone	City	LCOE_PV (FCFA/kWh)	LCOE_PVT (FCFA/kWh)	LCOE gain (%)
Guinean woman	Bouake	625	610	2%
Sudanese	Kandi	294	258	12%
Sudanese- Sahelian	Ouaga	300	271	10%
Sahelian	Bilma	400	350	12%
Sahara Desert	Kidal	502	462	8%

4. CONCLUSION

This study made a comparative analysis of the performance of PVT modules versus PV modules in the five West African climatic zones. The overall objective is to assess the potential value of promoting these types of modules in rural health areas for the simultaneous production of hot water and electrical energy in West African countries.

Simulation blocks with previously validated models of PVT and conventional modules were deployed in the Simulink environment of Matlab R2021a. The TMY meteorological data used were taken from the PVGIS website. The simulation of the different models developed, over a typical period of one year, allowed the estimation of the LCOE values of the technologies in the different climate zones.

The results obtained show that PVT modules offer LCOE gains ranging from 2% to 12% compared to conventional PV modules. The best performances of PVT modules are obtained in the Sudanese and Sudan-Sahelian climatic zones, while the Guinean zone shows the lowest gain.

REFERENCES

- [1] RAHMOUN Abdessamad, "DIMENSIONNEMENT D'UNE INSTALLATION PV HYBRIDE " APPLICATION A UN SYSTEME RACCORDE AU RESEAU ", Université Aboubekr Belkaid de Tlemcen, 2017. Accessed on: 10 June 2022. [Online]. Available from: <http://dspace.univ-tlemcen.dz/bitstream/112/11470/1/Ms.ELN.Rahmoun%2BHabibes.pdf>
- [2] " Putting Africa on the path to universal electricity access." <https://blogs.worldbank.org/fr/africacan/engager-lafrique-sur-la-voie-de-lacces-universel-lelectricite> (accessed July 10, 2022).

- [3] Y. Tripanagnostopoulos, Th. Nousia, M. Souliotis, and P. Yianoulis, "Hybrid photovoltaic/thermal solar systems," *Sol. Energy*, vol. 72, n° 3, pp. 217-234, March 2002, doi: 10.1016/S0038-092X(01)00096-2.
- [4] S. Abdul-Ganiyu, D. A. Quansah, E. W. Ramde, R. Seidu, and M. S. Adaramola, "Investigation of Solar Photovoltaic-Thermal (PVT) and Solar Photovoltaic (PV) Performance: A Case Study in Ghana," *Energies*, vol. 13, n° 11, Art. n° 11, Jan. 2020, doi: 10.3390/en13112701.
- [5] S. Abdul-Ganiyu, D. A. Quansah, E. W. Ramde, R. Seidu, and M. S. Adaramola, "Techno-economic analysis of solar photovoltaic (PV) and solar photovoltaic thermal (PVT) systems using exergy analysis," *Sustain. Energy Technol. Assess.* vol. 47, pp. 101520, Oct. 2021, doi: 10.1016/j.seta.2021.101520.
- [6] M. E. A. Slimani, M. Amirat, I. Kurucz, S. Bahria, A. Hamidat, and W. B. Chaouch, "A detailed thermal-electrical model of three photovoltaic/thermal (PV/T) hybrid air collectors and photovoltaic (PV) module: Comparative study under Algiers climatic conditions," *Energy Convers. Manag.*, vol. 133, pp. 458-476, Feb. 2017, doi: 10.1016/j.enconman.2016.10.066.
- [7] R. S. Kulkarni, D. B. Talange, A. A. Dharme, and N. V. Mate, "Development and performance analysis of solar photovoltaic-thermal (PVT) systems," *Sādhanā*, vol. 45, n° 1, p. 208, Dec. 2020, doi: 10.1007/s12046-020-01450-x.
- [8] O. E. Manssouri *et al*, "Performance Analysis of Bi-fluid Photovoltaic/ Thermal (PV/T) Solar Collector," in *2019 7th International Renewable and Sustainable Energy Conference (IRSEC)*, Agadir, Morocco, Nov. 2019, pp. 1-6. doi: 10.1109/IRSEC48032.2019.9078257.
- [9] A. K. Tossa, Y. M. Soro, Y. Azoumah, and D. Yamegueu, "A new approach to estimate the performance and energy productivity of photovoltaic modules in real operating conditions," *Sol. Energy*, vol. 110, pp. 543-560, Dec. 2014, doi: 10.1016/j.solener.2014.09.043.
- [10] A. K. Tossa *et al*, "Artificial intelligence technique for estimating PV modules performance ratio under outdoor operating conditions," *J. Renew. Sustain. Energy*, vol. 10, n° 5, p. 053505, Sep. 2018, doi: 10.1063/1.5042217.
- [11] B. I. Ouedraogo, S. Kouame, Y. Azoumah, and D. Yamegueu, "Incentives for rural off grid electrification in Burkina Faso using LCOE," *Renew. Energy*, vol. 78, pp. 573-582, June 2015, doi: 10.1016/j.renene.2015.01.044.
- [12] A. K. Tossa M. Z. Koalaga, M. A. Migan-Dubois, M. I. Youm, M. J. Merten, M. Y. Coulibaly, and M. M. Soro, "Etude comparative des performances de technologies photovoltaïques dans différentes zones climatiques de l'Afrique de l'Ouest," p. 171.

DEFINITIONS, ACRONYMS, ABBREVIATIONS

Symbols:

a	discount rates
C_R	residual cost of main equipment
C_{st}	binary parameter allowing to integrate or not the C_R or the d_m
d_m	dismantling cost
E_{jel}	daily electrical energy requirement, kWh
E_{jth}	daily thermal energy requirement, kWh
	Minimum value over the year of the monthly averages of the daily irradiation of the site considered, kWh/m /d
I_0	initial investment
LCC	project life cycle cost , discounted to year 0
LCOE	levelized cost of energy

Maintenance cost for cleaning the photovoltaic panels
Project life in years
 P_c then PV or PVT field power, W_p
Performance ratio integrating module efficiency and various losses
(cables, dust, etc.)
 Q_{energy} generated over the period N , kW

UNDER PEER REVIEW