

Sinusoidal PWM vs SVPWM for NPC Multilevel inverter with Proportional control based neutral point voltage controller for induction motor drive

Abstract: This study investigates the comparison between sinusoidal PWM and SVPWM for three level for v/f control of induction motor drive under different modulation indices as well as proposes Proportional control based neutral point controller for neutral point voltage balancing. The simulation results obtained in the MATLAB/Simulink environment demonstrate the superiority of the proposed method while compared to the corresponding techniques.

Keywords: Sinusoidal PWM, SVPWM, NPC multilevel inverter, induction motor drive, neutral point voltage controller.

Introduction

Prior to the introduction of Multi-level inverters (MLI), the two-level voltage source inverter (VSI) ruled the industrial world since it has a wide range of applications in transportation and industrial control. For the past couple of decades, Neutral Point Clamped (NPC) or Diode clamped Multi-Level Inverters (MLI) have dominated the power electronics industry [1]-[4]. When compared to two-level inverters, these inverters have less device stresses, lower voltage harmonic distortion and lower converter losses. A. Nabae, et al., developed [5] NPC the three-level inverter in 1981 as shown in Fig.1. Two capacitors on the DC bus link, four switching devices per phase, and two clamping diodes per phase make up an NPC three-level inverter. By utilising two capacitors, C1 and C2, the DC bus voltage is divided into three levels. Voltage stress will be confined to one capacitor level by clamping diodes, and each capacitor splits voltage as $V_{dc}/2$. The three level inverter's output voltage will be in three levels: $V_{dc}/2$, 0 and $-V_{dc}/2$ whereas for two level inverter's output voltage will be in two levels: $+V_{dc}$ and $-V_{dc}$. Pulse-Width Modulation (PWM) techniques are used to control drives, and they are divided into categories likely, Sinusoidal PWM, Multi-carrier PWM (MC PWM), Selective Harmonic Elimination (SHE PWM), and Space Vector PWM (SVPWM). In this context SVPWM outperforms Sinusoidal PWM approaches in terms of output voltage and harmonic reduction [6]-[7]. By ignoring the switching states that create high common mode voltage (CMV), it is simple to reduce CMV in SVPWM. Also because pulses in the SVPWM approach are digital, it is simple to use the DC-link in SVPWM. Although the SVPWM approach improves the performance of the NPC three-level inverter, it still has significant drawbacks, such as CMV and DC link balancing. However, because the DC-link voltage is split by capacitors in the NPC three-level inverter, current flowing out or into the neutral point might cause neutral point unbalance. Unbalanced neutral point voltage increases output voltage harmonics, can cause output voltage drift to an unacceptable level, and can damage switching devices and filter capacitors affecting the performance of the NPC three level inverter [8]-[9]. The neutral-point voltage is controlled in this article using a Proportional controller. A constant v/f induction motor drive with a 0.5HP output power is used to test the controller. The midpoint of two series-connected capacitors serves as the neutral point.

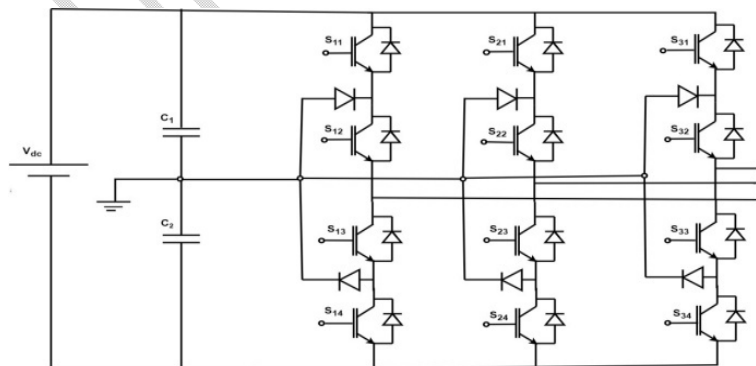

Figure 1. Schematic diagram of Neutral point clamping based three level inverter

Sinusoidal PWM:

A common PWM approach is sinusoidal PWM. The sinusoidal AC voltage reference is compared in real time with the high-frequency triangle carrier wave to determine switching times for each switches in the inverter. The amplitude of the voltage reference must remain below the peak of the triangle carrier in this PWM approach in order to achieve linear modulation[10]-[11]. This type of PWM technique is known as a carrier-based PWM approach because it uses a high-frequency carrier wave for voltage modulation. Because the reference is presented as the shape of a sine wave, this carrier-based technique is known as SPWM[12]-[13]. Because it uses the carrier of a triangular wave, it's also known as the triangle-comparison PWM approach. Fig. 2 shows the modulating waveform for sinusoidal PWM, which contains two triangular carrier waves for pulse generation since a three-level NPC inverter has four switches in a single leg, whereas a two-level inverter has just two switches in a single leg, resulting in only one carrier wave.

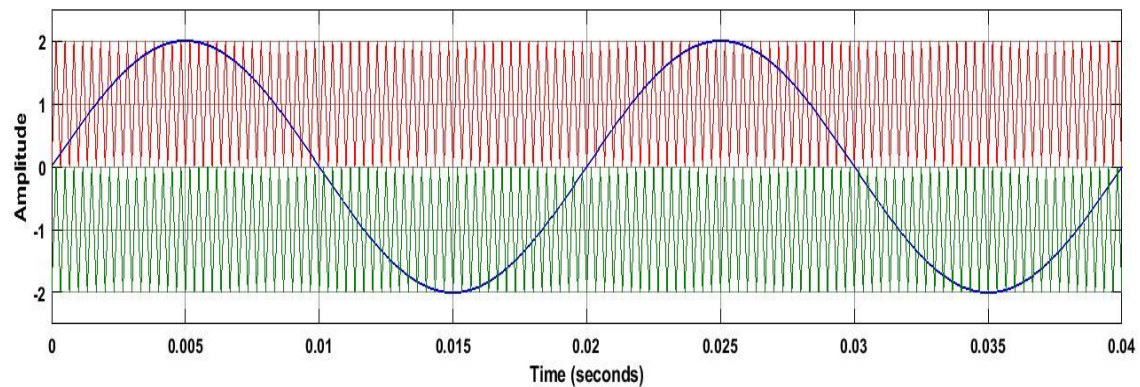

Figure .2. Modulating waveform for Sinusoidal PWM.

Space vector PWM

The Space vector PWM method is a digital modulation approach that generates PWM using a vector representation. These digital signals can be transmitted to switches that are controlled using a vector representation [14]-[20]. The magnitudes and phases of each vector are represented by placing the vectors in a hexagonal pattern. With 3 zero vectors, 12 small vectors, 6 medium vectors, and 6 large vectors, the three-level inverter has 27 switching states. Eight of the 27 switching states are redundancy states, whereas the remaining 19 voltage vector are shown in the space vector diagram in Figure 3. The SVPWM is divided into six sectors, each of which is further divided into four sub-sectors. The Schematic of Three level VSI is shown in fig 1. From the schematic each leg consists of four switches and two diodes. Diodes are connected to the midpoint of DC bus which ensure that voltage across any switch never exceeds one half of DC voltage. The capacitors C_1 and C_2 are connected to maintain constant voltage at neutral point. The middle point of two capacitors is referred as neutral point. The chosen Neutral Point Clamped three level inverter has a total of 27 vectors, similar to the SVPWM of two level inverter the hexagon comprises of six sectors respectively. The voltage at the output of inverter terminal will have three levels ($E/2, 0, -E/2$). Based on vector synthesis principle the adjacent vectors are synthesized in a certain sector. Out of 27 vectors the switching sequence is arranged in a fashion so that the ripple content in output current will be minimized[21]-[25]. The notation (+0-), + indicates phase R is connected to positive of DC bus, 0 indicates phase Y is connected to neutral point and - indicates phase B is connected to negative of DC bus. The simulation results of three level NPC are presented and discussed.

MATLAB/SIMULINK is used to analyze and compare neutral point clamped three level inverter fed IM using Sinusoidal PWM and Space vector PWM. Fig.8 & Fig.9 shows the voltage THD% where as Fig.6 & Fig.7 shows the current THD% for sinusoidal PWM and Space vector PWM and it also infers that there is THD% reduction with Space vector PWM for NPC three level inverter . Fig.11 shows the three level line to line output voltage. The gain of the P controller can be changed to influence the response of the neutral-point voltage controller. When the P is tuned online as a function of the power, In the future, it may be possible to reach ideal controller performance. however, this would necessitate more resources, during a change over time, compute. Fig.10 shows the DC link voltage with and without application of P controller it also infers that there is reduction in DC link voltage due to P controller.

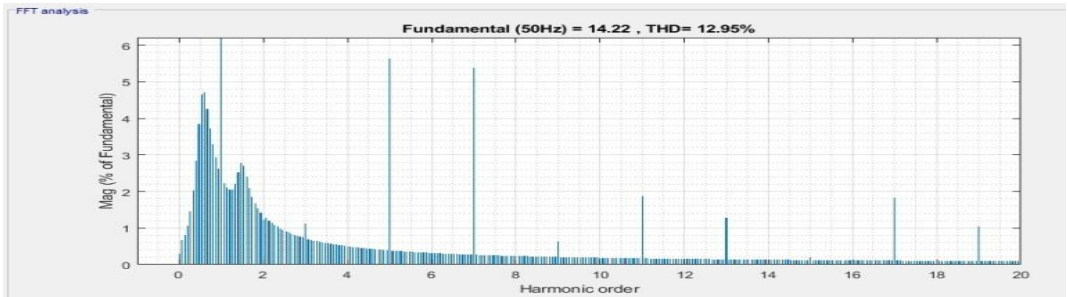

Figure 6. Current THD% for Sinusoidal PWM based three level inverter

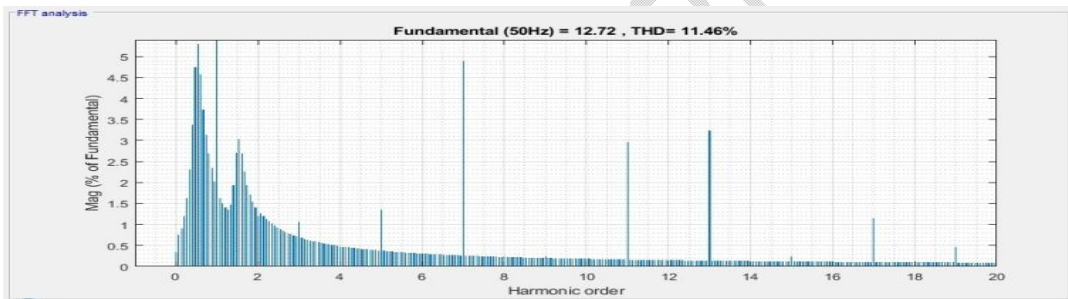

Figure 7. Current THD% for SVPWM based three level inverter

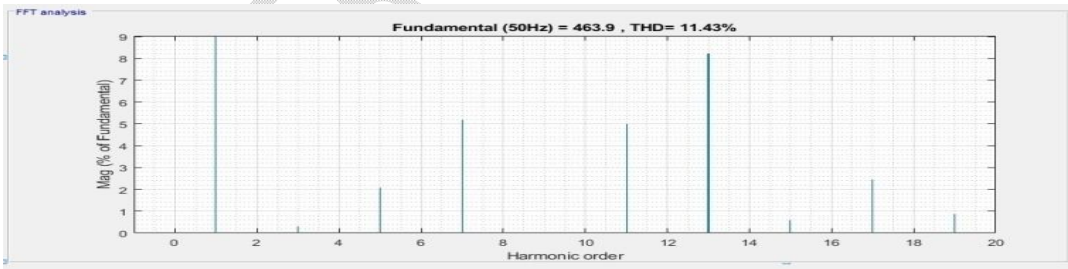

Figure 8. Voltage THD% for SVPWM based three level inverter

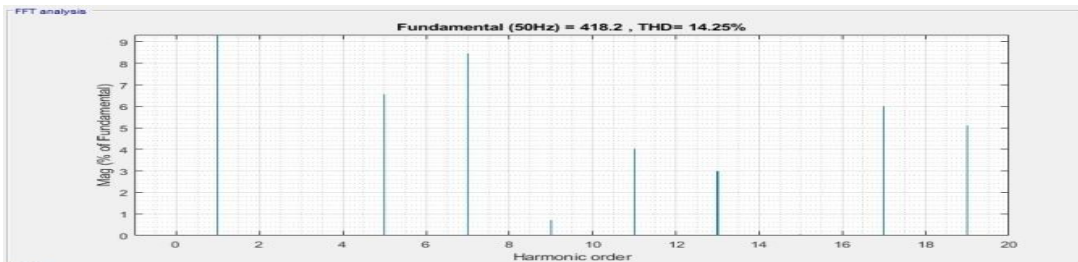

Figure 9. Voltage THD% for Sinusoidal PWM based three level inverter.

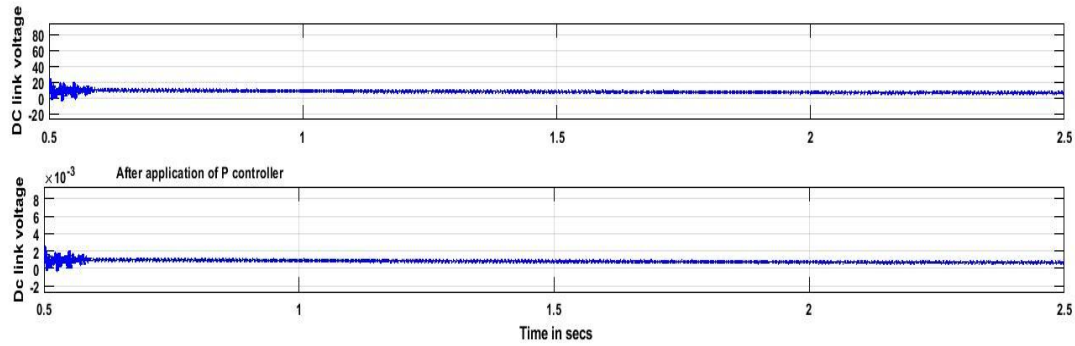

Figure 10. DC Link voltage

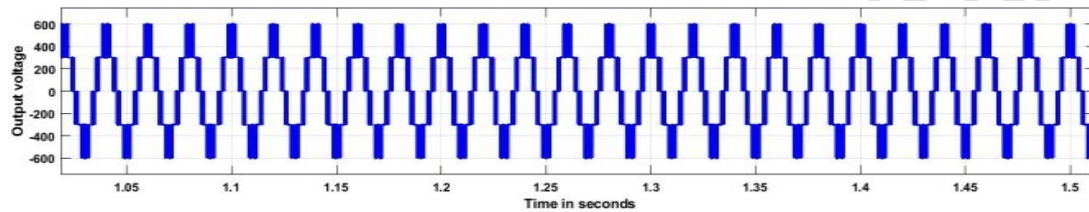

Figure 11. Three level output voltage

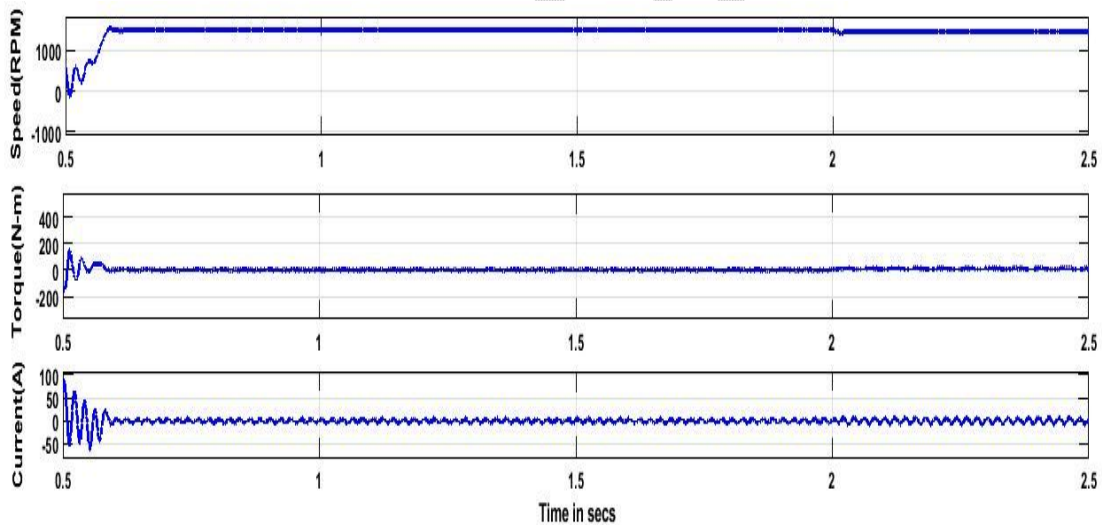

Figure 12. Speed-Torque responses for SVPWM based three level inverter fed induction drive.

Conclusion

A comprehensive and comparative study with detailed analysis is carried out for sinusoidal PWM and SVPWM for three level NPC inverters. The chosen performance parameters like stator current and voltage THD% are presented and analysed for both the techniques. Mathematical depiction vis-a-vis simulation in Matlab/Simulink gives a comprehensive understanding of comparative study. Based on the simulation results, it is observed that SVPWM performs better in three level NPC inverter compared to sinusoidal PWM by providing lesser THD and better DC bus utilisation. As the paper illustrates mathematical analysis apart from simulation study, it provides avenues to easily incorporate and analyse several other switching techniques for the chosen converter. This work also presents an NPC three-level inverter with P controller-based neutral point control and closed loop v/f control of an induction motor drive using space vector PWM. The suggested approach decreases

total harmonic distortion in the output stator current while also controlling the drive's speed and torque. Furthermore, the P controller, which is placed between two capacitor DC links, controls the neutral point current, saving switching devices and making the system more efficient for electric vehicle applications.

References

- [1] Rashid, Muhammad H. *Power electronics: circuits, devices, and applications*. Pearson Education India, 2009.
- [2] McGrath, Brendan Peter, and Donald Grahame Holmes. "Multicarrier PWM strategies for multilevel inverters." *IEEE Transactions on industrial electronics* 49.4 (2002): 858-867.
- [3] Nguyen, T.H., P.K.W. Chan, Y. Shrivastava and S.Y.R.Hui, 2005. "A Three Dimensional Space Vector Modulation Scheme for Three-Level Three-Wired Neutral Point Clamped Converters", IEEE 36th Power Electronics Specialists Conference 2005.pp.230-2314.
- [4] Lavanya, K., and V. Rangavalli. "A novel technique for simulation & analysis of SVPWM two & three-level inverters." *IJERA Journal* 3.5 (2013): 455-460.
- [5] Nabae, Akira, Isao Takahashi, and Hirofumi Akagi. "A new neutral-point-clamped PWM inverter." *IEEE Transactions on industry applications* 5 (1981): 518-523.
- [6] Rodriguez, Jose, Jih-Sheng Lai, and Fang Zheng Peng. "Multilevel inverters: a survey of topologies, controls, and applications." *IEEE Transactions on industrial electronics* 49.4 (2002): 724-738.
- [7] Bhalodi, Kalpesh H., and Pramod Agrawal. "Space vector modulation with DC-link voltage balancing control for three-level inverters." *2006 International Conference on Power Electronic, Drives and Energy Systems*. IEEE, 2006.
- [8] Tan, Zhuohui, Yongdong Li, and Min Li. "A direct torque control of induction motor based on three-level NPC inverter." *2001 IEEE 32nd Annual Power Electronics Specialists Conference (IEEE Cat. No. 01CH37230)*. Vol. 3. IEEE, 2001.
- [9] Krishnan, R. "Electric Motor Drives Modeling, Analysis and Control Pearson Education." *Virginia Tech* (2001).
- [10] Baader, Uwe, Manfred Depenbrock, and Georg Gierse. "Direct self control (DSC) of inverter-fed induction machine: A basis for speed control without speed measurement." *IEEE transactions on industry applications* 28.3 (1992): 581-588.
- [11] Beig, Abdul Rahiman, G. Narayanan, and V. T. Ranganathan. "Modified SVPWM algorithm for three level VSI with synchronized and symmetrical waveforms." *IEEE transactions on industrial electronics* 54.1 (2007): 486-494.
- [12] Hu, Haibing, Wenxi Yao, and Zhengyu Lu. "Design and implementation of three-level space vector PWM IP core for FPGAs." *IEEE Transactions on power electronics* 22.6 (2007): 2234-2244.
- [13] Maheshwari, RamKrishan, Stig Munk-Nielsen, and Sergio Busquets-Monge. "Neutral-point current modeling and control for neutral-point clamped three-level converter drive with small DC-link capacitors." *2011 IEEE Energy Conversion Congress and Exposition*. IEEE, 2011.
- [14] Jayakumar, Vinoth, Bharatiraja Chokkalingam, and J. L. Munda. "A Comprehensive Review on Space Vector Modulation Techniques for Neutral Point Clamped Multi-Level Inverters." *IEEE Access* (2021).
- [15] Mondal, Subrata K., et al. "Space vector pulse width modulation of three-level inverter extending operation into overmodulation region." *IEEE Transactions on Power Electronics* 18.2 (2003): 604-611.
- [16] Gupta, Amit Kumar, and Ashwin M. Khambadkone. "A simple space vector PWM scheme to operate a three-level NPC inverter at high modulation index including overmodulation region, with neutral point balancing." *IEEE Transactions on Industry Applications* 43.3 (2007): 751-760.

- [17] Ben-Brahim, Lazhar. "A discontinuous PWM method for balancing the neutral point voltage in three-level inverter-fed variable frequency drives." *IEEE Transactions on Energy Conversion* 23.4 (2008): 1057-1063.
- [18] Gopinath, Anish, Aneesh Mohamed AS, and M. R. Baiju. "Fractal based space vector PWM for multilevel inverters—A novel approach." *IEEE transactions on industrial electronics* 56.4 (2008): 1230-1237.
- [19] Jiang, Wei-dong, et al. "Hybrid PWM strategy of SVPWM and VSVPWM for NPC three-level voltage-source inverter." *IEEE Transactions on Power Electronics* 25.10 (2010): 2607-2619.
- [20] Chaturvedi, P. K., S. Jain, and P. Agarwal. "Reduced switching loss pulse width modulation technique for three-level diode clamped inverter." *IET Power Electronics* 4.4 (2011): 393-399.
- [21] Lewicki, Arkadiusz, Zbigniew Krzeminski, and Haitham Abu-Rub. "Space-vector pulsewidth modulation for three-level NPC converter with the neutral point voltage control." *IEEE Transactions on Industrial Electronics* 58.11 (2011): 5076-5086.
- [22] Chen, Juan, et al. "A comprehensive study on equivalent modulation waveforms of the SVM sequence for three-level inverters." *IEEE Transactions on Power Electronics* 30.12 (2015): 7149-7158.
- [23] Xia, Changliang, et al. "Adjustable proportional hybrid SVPWM strategy for neutral-point-clamped three-level inverters." *IEEE Transactions on Industrial Electronics* 60.10 (2012): 4234-4242.
- [24] Das, Soumitra, G. Narayanan, and M. Pandey. "Space-vector-based hybrid pulsewidth modulation techniques for a three-level inverter." *IEEE transactions on power electronics* 29.9 (2013): 4580-4591.
- [25] S. Bhattacharya, D. Mascarella, and G. Joos, "Space-Vector-Based Generalized Discontinuous Pulsewidth Modulation for Three-Level Inverters Operating at Lower," *IEEE J. Emerg. Sel. Top. Power Electron.*, vol. 5, no. 2, pp. 912–924, 2017.
- [26] E. Nandhini and A. Sivaprakasam: "A Review of Various Control Strategies Based on Space Vector Pulse Width Modulation for the Voltage Source Inverter", *IETE Journal of Research*,(2020).
- [27] A. Sivaprakasam & E. Nandhini (2021): 30° Discontinuous PWM-Based Closed Loop Volts/Hz Control of Induction Motor Drive with Slip Regulation, *IETE Journal of Research*, DOI: 10.1080/03772063.2021.2004457.