

1 **Idling and short-circuit analysis of a three-**
2 **phase power transformer represented by**
3 **a scheme with distributed parameters and**
4 **Π line scheme in the electrical network**

5
6
7
8 **ABSTRACT**
9

Aims: The paper presents a simulation of a theoretical model of electromagnetic extreme regimes, idling and short circuit, in a three-phase power transformer. The main goal of this paper is to show in a quality way that the computer simulation of the obtained theoretical model using the software package MATLAB Simulink confirms the possibility of analyzing the extreme modes of transformers.

Methodology: To solve the problem of the presence of a transformer as an element of power in the power system, the following are used: analytical methods in which the transformer is presented as a network element - usually as a quadripole, numerical programming that includes dynamic programming and independent variables, and combined programming with integer values. In the process simulation on elements with given parameters and frequency, a comparison of the substitution schemes used so far in the theory of electric circuits is performed. The accuracy of these theoretical models can be confirmed by voltage and current diagrams in the adapted software package MATLAB Simulink.

Conclusion: The presented theoretical model and the applied algorithm in the simulation are universal and can be used for different states in which a three-phase power transformer can be found. Problems that occur in the analysis of transient processes in electrical networks where the element is a transformer can be minimized using simulation methods. Changing any parameter in the electrical circuit requires a new calculation of the condition of the circuit from the very beginning due to the new initial conditions. Analytical methods combined with the simulation method were used in the research of extreme regimes, such as idling and short circuit. The verified simulation method realized using the adapted MATLAB Simulink program had a three fold purpose: to serve the calculation and simulation of quantities that can be obtained by testing or measuring, to establish the original algorithm and to verify the proposed method. Also, this type of simulation can replace the idle and short circuit test.

10
11 *Keywords: Simulation, model, electrical network, three-phase power transformer, power line,*
12 *quadripole*

13 **1. INTRODUCTION**
14

15 Preparation of computer programs in the method of organized modeling is called pre-
16 processing in the technical literature (formation of technical system models). Modeling is a
17 mathematical, graphic, IT and technical operation intended for analysis and evaluation of
18 various variants of electrical structure.

19 Processes in devices with complex geometry due to the content of a large number of sub-
20 areas with various electrical, magnetic and conductive properties are solved using network
21 methods whose modification is the final element method, FEM (Rica, Galerkina, etc.). The
22 essence of method is in testing approximations of solutions of differential equations with a
23 finite number of linear combinations of forms of basic functions [1]. The form of the base
24 function and criteria for calculating coefficients of linear combinations also defines a method
25 of finding a solution.

26 There are cable lines in distribution network (underground lines with insulated conductors),
27 overhead lines with uninsulated (bare) conductors and overhead lines with insulated
28 conductors in small number of cases [2]. In the past, experiments or network analyzers have
29 been used to analyze transient processes in electrical networks containing power sources,
30 lines and power elements (transformers or arbitrary electrical loads) [3,4]. These procedures
31 were highly intricate in nature and without a real answer to influence of parameters of the
32 network elements on process character. Today, parameters given in the domain of
33 symmetric components are mainly used for calculation of line parameters [5-7].
34 In this paper, the Π and T line scheme was used to determine the quadripole coefficients.
35 Behavior of a three-phase power transformer connected to an electric line represented by a
36 scheme with distributed parameters and a Π scheme of lines in the electric network was also
37 analyzed. With help of the MATLAB Simulink software package, a simulation with short-
38 circuit and idle diagrams of a three-phase power transformer was presented.

40 2. OVERVIEW OF RELEVANT PAPERS

41
42 The beginning of transformers development is connected with appearance and transmission
43 of alternating current. The first transformers are result of work of a Russian engineer PN.
44 Jablovkov, then L. Goulard and JD. Gibbsa, as well as SZ. de Ferrary and W. Stanley.
45 The theory of single-phase and three-phase machines and transformers was developed in
46 the first half of the XX century: АИ. ПА. Abeti [4], Вольдек [8], Bergeron [9], Fitzgerald [10]
47 are just some of the names of hundreds of engineers and scientists who have published
48 papers in the field of machines and transformers. In the available literature, only the
49 fundamental harmonic is taken into account in analysis of normal and transient states, and
50 method of symmetrical components is most often used for the analysis [11]. However, new
51 contributions were made by Match [12] and Chapman [13], who in their works mainly
52 analyze normal stationary states with one frequency and classical transformer parameters.
53 In the early papers and books of the past 100 years, the majority of electricity quality issues
54 and parameters were not given much attention or consideration as the topic was not deemed
55 particularly significant. Today, most of applied transformers have high values of power and
56 voltage, which imposes problem of determining higher harmonics (not only the fundamental)
57 voltage and current and their distribution along the windings [14].

59 3. ANALYSIS OF THE NETWORK ELEMENT MODEL AS A QUADRIPOLES

60
61 Quadripoles are used in the theory of electric circuits to model elements such as lines,
62 transformers, powerful electrical receivers, etc. Transformers can be modeled as electrical
63 elements of electrical networks Π , Γ , vice-versa Γ or T schemes [15,16].
64 If the line element has distributed parameters, it is represented by a quadripoles model and
65 more easily considers the wave character of energy transfer through that part [17,18].
66 Voltages, currents and power flow at the inlet or outlet of line are determined from the
67 equivalent scheme. In a similar way, given the spatial distribution of coils that have defined
68 characteristics and dimensions in transformer windings, it is possible to consider the
69 transformer winding as a quadrilateral. Below is a quadrilateral model created for the
70 transformer winding. According to the method of Kirchhoff's rules for voltages in contours:

$$71 \quad \sum (V_k - Z_k I_k) = 0 \quad (1)$$

72 and currents in the nodes:

$$73 \quad \sum (I_i) = 0 \quad (2)$$

74 and provided that in the outer part of the circuit current I_1 and voltage V_1 at the output and
75 current I_2 and voltage V_2 at the output they remain the same in amplitude and argument
76 beyond the ends 1-1' and 2-2' quadripoles, figure 1.a one can realize the transfiguration of

77 the structure from a triangle to a star and vice versa within the nodes 1, 2, 1'=3(0), 2'=3(0)
 78 and following relations, figure 1.b and 1.c:

$$79 \quad Z_1 = \frac{Z_{12}Z_{31}}{Z_{12} + Z_{23} + Z_{31}} = \frac{Y_{23}}{Y_{12}Y_{23} + Y_{23}Y_{31} + Y_{31}Y_{12}}, \quad Z_{12} = Z_1 + Z_2 + \frac{Z_1Z_2}{Z_3} = \frac{Y_1 + Y_2 + Y_3}{Y_1Y_2}$$

$$80 \quad Z_2 = \frac{Z_{12}Z_{23}}{Z_{12} + Z_{23} + Z_{31}} = \frac{Y_{31}}{Y_{12}Y_{23} + Y_{23}Y_{31} + Y_{31}Y_{12}}, \quad Z_{23} = Z_2 + Z_3 + \frac{Z_2Z_3}{Z_1} = \frac{Y_1 + Y_2 + Y_3}{Y_2Y_3} \quad (3)$$

$$81 \quad Z_3 = \frac{Z_{23}Z_{31}}{Z_{12} + Z_{23} + Z_{31}} = \frac{Y_{12}}{Y_{12}Y_{23} + Y_{23}Y_{31} + Y_{31}Y_{12}}, \quad Z_{31} = Z_3 + Z_1 + \frac{Z_3Z_1}{Z_2} = \frac{Y_1 + Y_2 + Y_3}{Y_3Y_1}$$

82 Quadripole with current I_1 and voltage V_1 on the input and current I_2 and voltage V_2 on the
 83 output is presented on the figure 1.a (the linear quadripole has no independent sources and
 84 the circuit has no converted energy). Independent parameters of the internal structure are
 85 immittances (impedances Z and/or admittance Y). Quadripoles are used to analyze the
 86 transmission of energy on lines [19]. A couple of ends (1-1') represents the entrance, and a
 87 couple of ends (2-2') the quadripole output is reserved for the receiver connection. The
 88 analysis of quadripoles determines the expressions that connect voltages, currents and
 89 powers in selected branches between input and output quantities. An arbitrary quadripole
 90 with two pairs of ends, figure 1.a, regardless of the internal structure is represented by $\Pi(\Delta)$
 91 scheme, figure 1.b and 1.d and $T(Y)$ scheme, figure 1.c and 1.e [2].
 92

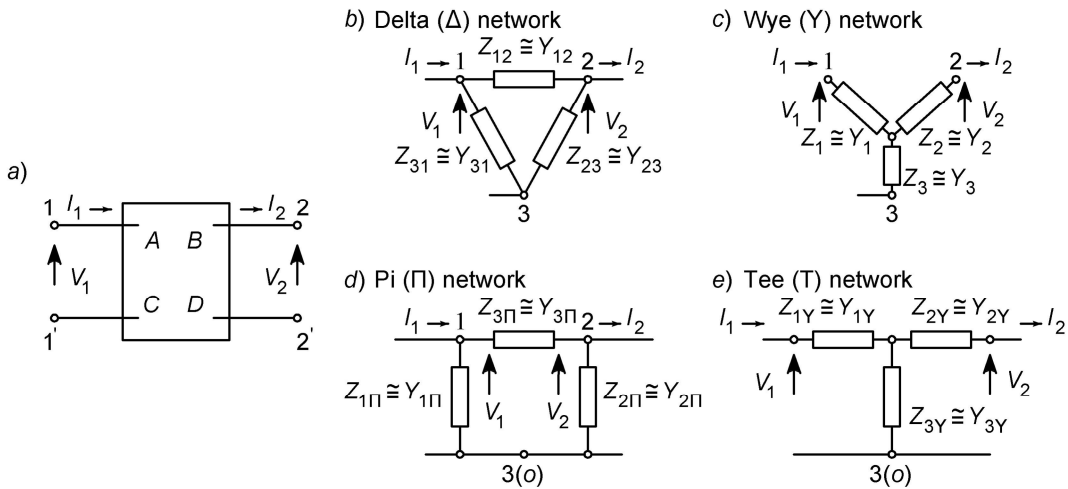

93
 94

95 **Fig. 1. a) Quadripole scheme, b) and d) $\Pi(\Delta)$ scheme, c) and e) $T(Y)$ scheme**

96 For $\Pi(\Delta)$ scheme on figure 1.b and 1.d with impedance $Z_{1\Pi}$, $Z_{2\Pi}$, $Z_{3\Pi}$ (or agreeable
 97 admittance $Y_{1\Pi}$, $Y_{2\Pi}$, $Y_{3\Pi}$) following equations applied for:

$$98 \quad \text{Voltage: } V_1 = \left(I_2 + \frac{V_2}{Z_{2\Pi}} \right) Z_{3\Pi} + V_2 = \left(1 + \frac{Z_{3\Pi}}{Z_{2\Pi}} \right) V_2 + Z_{3\Pi} I_2 = AV_2 + BI_2 \quad (4)$$

$$99 \quad \text{where: } A = 1 + \frac{Z_{3\Pi}}{Z_{2\Pi}}, \quad B = Z_{3\Pi},$$

$$100 \quad \text{Current: } I_1 = \frac{V_1}{Z_{1\Pi}} + \frac{V_2}{Z_{2\Pi}} + I_2 = \left(\frac{1}{Z_{1\Pi}} + \frac{1}{Z_{2\Pi}} + \frac{Z_{3\Pi}}{Z_{1\Pi}Z_{2\Pi}} \right) V_2 + \left(1 + \frac{Z_{3\Pi}}{Z_{1\Pi}} \right) I_2 = CV_2 + DI_2 \quad (5)$$

$$101 \quad \text{where: } C = \left(\frac{1}{Z_{1\Pi}} + \frac{1}{Z_{2\Pi}} + \frac{Z_{3\Pi}}{Z_{1\Pi}Z_{2\Pi}} \right), \quad D = \left(1 + \frac{Z_{3\Pi}}{Z_{1\Pi}} \right).$$

102 For T(Y) scheme on figure 1.c and 1.e with impedance Z_{1Y}, Z_{2Y}, Z_{3Y} (or ageable
103 admittance Y_{1Y}, Y_{2Y}, Y_{3Y}) we can write following equations for:

104 Current: $I_1 = I_2 + I_3 = I_2 + \frac{V_2 + Z_{2Y}I_2}{Z_{3Y}} = \frac{1}{Z_{3Y}} V_2 + \left(1 + \frac{Z_{2Y}}{Z_{3Y}}\right) I_2 = CV_2 + DI_2$ (6)

105 where: $C = \frac{1}{Z_{3Y}}, D = 1 + \frac{Z_{2Y}}{Z_{3Y}},$

106 Voltage: $V_1 = Z_{1Y}I_1 + Z_{2Y}I_2 + V_2 = \left[\frac{1}{Z_{2Y}}V_2 + \left(1 + \frac{Z_{2Y}}{Z_{3Y}}\right)I_2\right]Z_{1Y} + Z_{2Y}I_2 + V_2 =$
 $= \left(1 + \frac{Z_{1Y}}{Z_{3Y}}\right)V_2 + \left(Z_{1Y} + Z_{2Y} + \frac{Z_{1Y}Z_{2Y}}{Z_{3Y}}\right)I_2 = AV_2 + BI_2$ (7)

107 where: $A = 1 + \frac{Z_{1Y}}{Z_{3Y}}, B = Z_{1Y} + Z_{2Y} + \frac{Z_{1Y}Z_{2Y}}{Z_{3Y}}.$

108 Based on the previous relations, it is shown that the two internal schemes differ only in
109 admittances $Y_{1\Pi}, Y_{2\Pi}, Y_{3\Pi}$ and $Y_{1Y}, Y_{2Y}, Y_{3Y}.$

110 There is a dependence between the coefficients of the quadripole A, B, C and D and in
111 both schemes $AD - BC = 1$, which is checked by equation:

112 $\left(1 + \frac{Z_{3\Pi}}{Z_{2\Pi}}\right)\left(1 + \frac{Z_{3\Pi}}{Z_{1\Pi}}\right) - Z_{3\Pi}\left(\frac{1}{Z_{1\Pi}} + \frac{1}{Z_{2\Pi}} + \frac{1}{Z_{1\Pi}}\right) = 1$ (8)

113 The coefficients can be determined by means of derived relations or experimentally from the
114 no-load or short-circuit test if the input and output ends of quadripole are accessible. This is
115 very important when the internal structure of quadripole is unknown [20]. In the continuation
116 of this paper, the influence of choice of the type of line scheme (distributed parameters and
117 Π scheme) on values and shapes of the obtained currents and voltages was examined.

118

119 **4. STATE OF ELECTRIC LINE PRESENTED BY SCHEME WITH DISTRIBUTED**
120 **PARAMETERS AND Π SCHEME**

121

122 Transmission lines are also shown as four-terminals with combined z - and y -parameters,
123 and its structure is Π or T scheme. From these schemes we move on to the characteristics
124 that represent the mode of transmission described by the parameters of intrinsic or mutual
125 conductivity (admittances y) or resistances (impedances z) [20-22].

126 The no-load test is performed under condition that the no-load voltage corresponds to rated
127 voltage of receiver at the ends 2-2' $V_2 = V_{2o} = V_{2n}$, and a short circuit test to short circuit
128 current $I_2 = I_{2sh.c}$ corresponds to rated current of receiver at the ends 2-2' when the
129 structure of a quadripole is a combination of Y, Z parameters: $Z_{1\Pi} \cong Y_{1\Pi}, Z_{2\Pi} \cong Y_{1\Pi},$
130 $Z_{3\Pi} \cong Z_{1\Pi}$, figure 2.a,b [6].

131

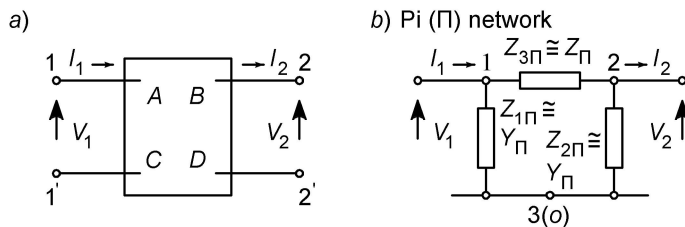

132

133

134 **Fig. 2. a) Quadripole scheme, b) Π line scheme**

135

136 As we have already said, a line is an element with distributed parameters, and the selected
137 model contains parameters (per unit length for total length). The unit longitudinal parameters
138 are: $R = r \cdot l$, $L_p = l_p \cdot l$, $G = g \cdot l$ and $C = c \cdot l$.

139 Transformation from equations of finite differences into equations with integral-differential
140 form is possible [23]. The influence of the ferromagnetic material of the magnetic circuit and
141 the processes in it have not been the subject of attention here. All line parameters are linear,
142 so the principle of superposition can be applied.

143 If the line is presented as a circuit with concentrated parameters, the wave character of long
144 lines should be considered. The solution of the transient process in a single-phase line with
145 distributed parameters is:

$$146 \quad \begin{aligned} V_1 &= ch\gamma_0 l \cdot V_2 + Z_c sh\gamma_0 l \cdot I_2 \\ I_1 &= \frac{1}{Z_c} sh\gamma_0 l \cdot V_2 + ch\gamma_0 l \cdot I_2 \end{aligned} \quad (9)$$

147 where $ch\gamma_0$, $sh\gamma_0$ are the coefficients of power distribution elements (lines, transformer...).

148 The parameters of the replacement scheme of long lines if the line is presented as a
149 quadripole are:

$$150 \quad \begin{aligned} V_1 &= A \cdot V_2 + \sqrt{3} B \cdot I_2 \\ I_1 &= (1/\sqrt{3}) C \cdot V_2 + D \cdot I_2 \end{aligned} \quad (10)$$

151 where are the coefficients of the quadripole $A = ch\gamma_0 l$, $B = Z_c sh\gamma_0 l$, $C = \frac{1}{Z_c} sh\gamma_0 l$,

152 $D = ch\gamma_0 l$.

153 If the line introduces it self with Π scheme and considers idle mode regime in Π scheme at
154 the end of the line, then the following expressions are obtained:

$$155 \quad A = \frac{V_1}{I_1} \Big|_{I_2=0}, \quad V_1 = V_2 + Z_{\Pi} Y_{\Pi} \cdot V_2$$

$$156 \quad I_1 = \frac{Y_{\Pi}}{\sqrt{3}} V_1 + \frac{1}{\sqrt{3} \left(Z_{\Pi} + \frac{1}{Y_{\Pi}} \right)} V_1 = \frac{1}{\sqrt{3}} \left(Y_{\Pi} + \frac{Y_{\Pi}}{1 + Z_{\Pi} Y_{\Pi}} \right) \cdot V_1 \quad (11)$$

$$157 \quad I_1 = \frac{V_2}{\sqrt{3}} (1 + Z_{\Pi} Y_{\Pi}) \left(Y_{\Pi} + \frac{Y_{\Pi}}{1 + Z_{\Pi} Y_{\Pi}} \right) = \frac{1}{\sqrt{3}} (2 Y_{\Pi} + Z_{\Pi} Y_{\Pi}^2) \cdot V_2$$

158 For quadripole in idle mode presented with Π scheme at the end of the line, we get:

$$159 \quad \begin{aligned} V_1 &= A \cdot V_2 \\ I_1 &= C \cdot V_2 / \sqrt{3} \end{aligned} \quad (12)$$

160 where: $A = \frac{V_1}{I_1} \Big|_{I_2=0} = 1 + Z_{\Pi} Y_{\Pi}$, $C = 2 Y_{\Pi} + Z_{\Pi} Y_{\Pi}^2$.

161 If line is presented with Π scheme and if short circuit mode in Π scheme at the end of the line
162 is considered, following expressions are obtained:

$$163 \quad \begin{aligned} V_1 &= \sqrt{3} \cdot Z_{\Pi} \cdot I_2 \\ I_1 &= \frac{1}{\sqrt{3}} \cdot V_1 \left(\frac{1}{Z_{\Pi}} + Y_{\Pi} \right) = \frac{\sqrt{3} Z_{\Pi} I_2}{\sqrt{3}} \left(\frac{1 + Z_{\Pi} Y_{\Pi}}{Z_{\Pi}} \right) = (1 + Z_{\Pi} Y_{\Pi}) \cdot I_2 \end{aligned} \quad (13)$$

164 Analog relations for quadripole in the short-circuit mode presented with Π scheme at the end
165 of the line are:

$$166 \quad V_1 = \sqrt{3} \cdot B \cdot I_2 \quad (14)$$

$$I_1 = D \cdot I_2$$

167 where: $B = Z_{\Pi}$, $D = (1 + Z_{\Pi} Y_{\Pi}) = A$.

168 Relations that connect constants and parameters are:

$$169 \quad \begin{aligned} ch_{\gamma_0 l} = A = 1 + Z_{\Pi} Y_{\Pi}, \quad ch_{\gamma_0 l} = D = (1 + Z_{\Pi} Y_{\Pi}) = A \\ Z_c sh_{\gamma_0 l} = B = Z_{\Pi}, \quad \frac{1}{Z_c} sh_{\gamma_0 l} = C = 2Y_{\Pi} + Z_{\Pi} Y_{\Pi}^2 \end{aligned} \quad (15)$$

170 It is natural that uncompensated transmission line is a symmetrical quadripole because it is

171 $ch_{\gamma_0 l} = D = (1 + Z_{\Pi} Y_{\Pi}) = A$. From relations (15) values are easily determined for Z_{Π} , Y_{Π} ,

172 Π line shemes:

$$173 \quad \begin{aligned} Z_{\Pi} = Z_c sh_{\gamma_0 l} = \sqrt{\frac{Z_0}{Y_0}} sh_{\gamma_0 l} = \sqrt{\frac{Z_0 l}{Y_0 l}} sh_{\gamma_0 l} = Z_0 l \frac{sh_{\gamma_0 l}}{\gamma_0 l} = Z_0 l K_s \\ Y_{\Pi} = \frac{\gamma_0 l}{2} \frac{1}{Z_c} \frac{2}{\gamma_0 l} th\left(\frac{\gamma_0 l}{2}\right) = \frac{\sqrt{Z_0 Y_0}}{\sqrt{Z_0 / Y_0}} \frac{l}{2} \frac{th\left(\frac{\gamma_0 l}{2}\right)}{\left(\frac{\gamma_0 l}{2}\right)} = Y_0 \frac{1}{2} K_y \end{aligned} \quad (16)$$

174 Correction coefficients K_s and K_y which take into account the distribution of parameters

175 along the line (Ceneli coefficients) are:

$$176 \quad \begin{aligned} K_s = k_s \angle \varphi_s = \frac{sh_{\gamma_0 l}}{\gamma_0 l} = \frac{sh \sqrt{Z_0 Y_0} \cdot l}{\sqrt{Z_0 Y_0} \cdot l} \\ K_y = k_y \angle \varphi_s = \frac{th\left(\frac{\gamma_0 l}{2}\right)}{\frac{\gamma_0 l}{2}} = \frac{th\left(\frac{l}{2} \sqrt{Z_0 Y_0}\right)}{\frac{l}{2} \sqrt{Z_0 Y_0}} \end{aligned} \quad (17)$$

177 Nomograms for determining correction coefficients K_s and K_y [1] are:

$$178 \quad K_s = \frac{sh_{\gamma_0 l}}{\gamma_0 l}, \quad K_y = \frac{th\left(\frac{\gamma_0 l}{2}\right)}{\frac{\gamma_0 l}{2}} \quad (18)$$

179 and are determined by first determining modulus and value argument $Z_0 Y_0 l^2$ where Z_0 and

180 Y_0 are longitudinal impedances and admittances, and l length of energy transmission line.

181 K_s and K_y are determined from the nomogram if the inequality condition is met

$$182 \quad |Z_0 Y_0 l^2| \leq 0.36 \quad [2].$$

183 If the correction coefficients cannot be determined directly from the nomogram due to

184 $|Z_0 Y_0 l^2| > 0.36$ the following procedure can be used:

$$185 \quad \sqrt{Z_0 Y_0} l = \sqrt{ZY} = \Phi, \quad \sqrt{Z_0 Y_0} \frac{l}{2} = \frac{1}{2} \sqrt{ZY} = \psi \Leftrightarrow \Phi = 2\psi \quad (19)$$

186 Correction coefficients for long lines $l[km]$ can be determined according to:

$$K_s = \frac{sh\gamma_0 l}{\gamma_0 l} = \frac{sh\sqrt{ZY}}{\sqrt{ZY}} = \frac{sh\Phi}{\Phi} = \frac{sh2\psi}{2\psi} = \frac{2sh\psi \cdot ch\psi}{2\psi} = \frac{sh\psi}{\psi} ch\psi \Leftrightarrow K_{sl} = K_{s,l/2} ch \frac{\sqrt{ZY}}{2}$$

$$K_s = \frac{th \frac{\sqrt{ZY}}{2}}{\frac{\sqrt{ZY}}{2}} = \frac{sh \frac{\sqrt{ZY}}{2}}{\frac{\sqrt{ZY}}{2}} \frac{1}{ch \frac{\sqrt{ZY}}{2}} \Leftrightarrow K_{yl} = K_{y,l/2} \frac{1}{ch \frac{\sqrt{ZY}}{2}}$$

From the relation (20) it is clear that the correction coefficients of the parameters of the replacement equivalent schemes of lines of 1000 [km] length are calculated by multiplying two terms, each of which characterizes a line of length $l/2$ and the modulus and complex-valued argument can be specified $|Z_0 Y_0 l^2|/4$.

The complex value of the line constant A of length l , is determined as:

$$A = ch\sqrt{ZY} = ch2 \frac{\sqrt{ZY}}{2} = ch^2 \frac{\sqrt{ZY}}{2} + sh^2 \frac{\sqrt{ZY}}{2} = 2ch^2 \frac{\sqrt{ZY}}{2} - 1 \Leftrightarrow A_l = 2A_{l/2}^2 - 1 \quad (21)$$

where constant A can be determined from the nomogram.

4.1. Characteristics of Π scheme of lines

According to the previously derived relations, it is possible to determine the parameters of lines with distributed parameters or equivalent Π scheme of lines. Calculation results are presented in table 1.

Table 1. Determination of lines parameters

l [km]	$Z_{\Pi} = r_{\Pi} + jx_{\Pi}$ [Ω]	$y_{\Pi} 10^{-4} = (g_{\Pi} + jb_{\Pi}) 10^{-4}$ [Ω^{-1}]	$A = D, B = Z_{\Pi}, C 10^{-4}$ [Ω^{-1}]
500	6.21+j134.2	0.014+j10.98	0.852 +j0.007 -0.051+j20.35
1000	8.68+j227.3	0.136+j23.87	0.454 +j0.024 -0.372+j34.69

Marks in the table 1 are: r_{Π} active resistance, $x_{\Pi} = j\omega \cdot l_i$ reactance, g_{Π} conductance $b_{\Pi} = j\omega \cdot c$ susceptance.

A, B, C and D are parameters of the open circuit for they are determined as relation of voltage and current with opened output (current $I_2=0$) or input (current $I_1=0$) and are:

$$A = \frac{V_1}{I_1} \Big|_{I_2=0} = ch\sqrt{zy}l, B = \frac{V_1}{I_2} \Big|_{I_1=0} = Z_c sh\sqrt{zy}l$$

$$C = \frac{V_2}{I_1} \Big|_{I_2=0} = \frac{1}{Z_c} sh\sqrt{zy}l, D = \frac{V_2}{I_2} \Big|_{I_1=0} = A = ch\sqrt{zy}l \quad (22)$$

4.2. Replacement diagrams for lines and cables

In the theory of electrical circuits, the quadripole is defined by the diagram in figure 3 and the equations:

$$U_1 = AU_2 + BI_2, I_1 = CU_2 + DI_2 \quad (23)$$

or matrix:

$$\begin{bmatrix} U_1 \\ I_1 \end{bmatrix} = \begin{bmatrix} A & B \\ C & D \end{bmatrix} \begin{bmatrix} U_2 \\ I_2 \end{bmatrix} \quad (24)$$

218 In line case coefficients A , B , C and D have the following values:

$$219 \quad A = ch\sqrt{ZY}l, \quad B = Z_c sh\sqrt{ZY}l, \quad C = 1/Z_c sh\sqrt{ZY}l, \quad D = A = ch\sqrt{ZY}l \quad (25)$$

220

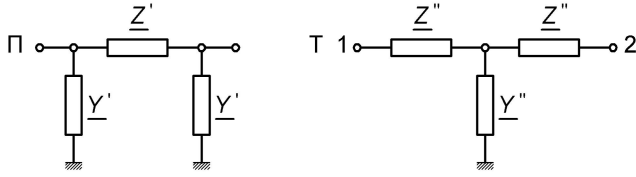

221

222

223

224

Fig. 3. Quadripole of T and Π shape that represents the line

225 Quadripole most frequently has the form of T or Π scheme where coefficients A , B , C and
226 D can be easily determined. It can be described with equation system:

$$227 \quad \underline{Z}' = \underline{B}, \quad \underline{Y}' = \underline{A} + 1/\underline{B}, \quad \underline{Z}'' = \underline{A} - 1/\underline{C}, \quad \underline{Y}'' = \underline{C} \quad (26)$$

$$228 \quad \underline{Z}' = \sqrt{\underline{Z}/\underline{Y}} sh\sqrt{\underline{ZY}l} = \underline{z}l \frac{sh\sqrt{\underline{ZY}l}}{\sqrt{\underline{ZY}l}} = \underline{z}l K_1 = \underline{Z}K_1 \quad (27)$$

$$\underline{Y}' = \frac{ch\sqrt{\underline{ZY}l}^{-1}}{\sqrt{\underline{Z}/\underline{Y}} sh\sqrt{\underline{ZY}l}} = \frac{1}{\sqrt{\underline{Z}/\underline{Y}}} th\sqrt{\underline{ZY}/2l} = \frac{\underline{Y}l}{2} \frac{th\sqrt{\underline{ZY}/2l}}{\sqrt{\underline{ZY}/2l}} = \frac{\underline{Y}l}{2} K_2$$

$$229 \quad \underline{Z}'' = \frac{ch\sqrt{\underline{ZY}l} - 1}{1/\sqrt{\underline{ZY}} sh\sqrt{\underline{ZY}l}} = \sqrt{\underline{ZY}} th\sqrt{\underline{ZY}/2l} = \underline{Z}l/2 \frac{th\sqrt{\underline{ZY}/2l}}{\sqrt{\underline{ZY}/2l}} = \frac{\underline{Z}l}{2} K_2 \quad (28)$$

229

$$\underline{Y}'' = 1/\sqrt{\underline{Z}/\underline{Y}} sh\sqrt{\underline{ZY}l} = \underline{Y}l \frac{sh\sqrt{\underline{ZY}l}}{\sqrt{\underline{ZY}l}} = \underline{Y}l K_1 = \underline{Y}K_1$$

230 K_1 and K_2 are the coefficients introduced in network analysis by Kennelly.

231 Correction factors that can be calculated by a relatively complex procedure are:

$$ch(\alpha + j\beta) = ch\alpha chj\beta + sh\alpha shj\beta = ch\alpha ch\beta + sh\alpha sh\beta$$

$$232 \quad sh(\alpha + j\beta) = sh\alpha chj\beta + ch\alpha shj\beta = sh\alpha \cos\beta + jch\alpha \sin\beta \quad (29)$$

$$sh\alpha = \sum_{k=0}^{\infty} \frac{\alpha^{(2k+1)}}{(2k+1)!} = \alpha + \alpha^3/3! + \dots, \quad ch\alpha = \sum_{k=0}^{\infty} \frac{\alpha^{2k}}{2k!} = 1 + \alpha^2/2$$

233 α and β depend on line parameters, α and β are small values and formulas for
234 calculations are obtained by Rudenberg's procedure.

235 The value of the coefficient K_1 is:

$$236 \quad K_1 = \frac{sh\sqrt{\underline{ZY}l}}{\sqrt{\underline{ZY}l}} \approx 1/\sqrt{\underline{ZY}} \left(\sqrt{\underline{ZY}l} + \frac{(\sqrt{\underline{ZY}l})^3}{3!} \right) \quad (30)$$

237 By introducing parameters $\lambda = \sqrt{bx}l$, i.e. factor $\rho = r/x$ we get: $K_1 = 1 - \lambda^2/6 + j\rho\lambda^2/6$.

238 The same procedure is used to derive the expression for K_2 and we get:

$$239 \quad K_2 = \frac{th\sqrt{\underline{ZY}l}/2}{\sqrt{\underline{ZY}l}/2} \approx \frac{1}{\sqrt{\underline{ZY}l}/2} \left(\frac{\sqrt{\underline{ZY}l}}{2} - \frac{(\sqrt{\underline{ZY}l}/2)^3}{3} \right), \quad K_2 = 1 - \lambda^2/12 - j\rho\lambda^2/12 \quad (31)$$

240 In case the line does not produce reactive power $q \approx 0$, $\sqrt{\underline{ZY}l} = \sqrt{(r+jx)jb}l = j\lambda\sqrt{1-j\rho}$

241 then coefficients K_1 and K_2 :

$$K_1 = j \frac{\sin \lambda \sqrt{1-j\rho}}{j\lambda \sqrt{1-j\rho}}, K_2 = \frac{j \operatorname{tg} \lambda \sqrt{1-j\rho}}{j\lambda \sqrt{1-j\rho}} / 2 \quad (32)$$

243 Values K_1 and K_2 are developed in a series by ρ and an equation is obtained in which
244 they are correction factors:

$$K_1 \approx \sin \lambda / \lambda - j\rho / 2 (\cos \lambda - \sin \lambda / \lambda), K_2 \approx \frac{\operatorname{tg} \lambda}{\lambda / 2} + j\rho / 2 \frac{\sin \lambda / \lambda - 1}{\cos^2 \lambda / 2} \quad (33)$$

$$\begin{aligned} \operatorname{Re}\{Z'\} &= r l \operatorname{Re}\{K_1\} - x l \operatorname{Im}\{K_1\} = r l \left[\operatorname{Re}\{K_r'\} - 1 / \rho \operatorname{Im}\{K_1\} \right] \\ \operatorname{Im}\{Z'\} &= r l \operatorname{Im}\{K_1\} + x l \operatorname{Re}\{K_1\} = x l \left[\operatorname{Re}\{K_x'\} + \rho \operatorname{Im}\{K_1\} \right] \end{aligned} \quad (34)$$

247 Below are the line parameters with distributed parameters and Π line scheme, as well as the
248 parameters of the three-phase power transformer SIMENS Yyn [24] that are used in
249 simulation.

250

251 5. PARAMETERS OF BOTH VARIANTS OF LINES AND TRANSFORMERS

252

253 5.1. Parameters of both lines types

254

255 In accordance with technical practice, the resistance and inductance of the coils in the per
256 unit system should be determined (p.u.).

257 For this simulation with frequency $f = 50$ [Hz], both equivalent circuit schemes were used,
258 namely: circuit with distributed parameters and Π scheme line.

259 Identical parameters are used:

260 Same length (length=20 [km]),

261 Line 1 Distributed = Line 2Pi,

262 3 phase A, B, C: $r_{1,2} = 0.01273$ [Ω /km], $r_0 = 0.2546$ [Ω /km],

263 $l_{1,2} = 0.93377 \cdot 10^{-3}$ [H/km], $l_0 = 18.66 \cdot 10^{-3}$ [H/km],

264 $c_{1,2} = 12.74 \cdot 10^{-9}$ [F/km], $c_0 = 0.637 \cdot 10^{-9}$ [F/km].

265

266 5.2. Transformer parameters

267

268 Transformer model in the MATLAB Simulink program package was implemented so that its
269 inputs are the source voltage vectors and the parameters of source and winding of
270 transformer, and the outputs are the flux vectors, magnetizing currents and variable unit
271 values of the primary and secondary voltages [1, 25, 26]. Simulation and analysis of behavior
272 of transformer in extreme regimes during transient process was carried out for no load and
273 short circuit, and consists of described simulation models of voltage and parameters of
274 source of lines and transformer.

275 Base values are rated power S_n [VA], rated frequency f_n [Hz], rated voltage V_n [V], effective
276 power value V_{rms} , as well as:

$$R_{base} = \frac{[V_n]^2}{S_n}, L_{base} = \frac{R_{base}}{2\pi f_n}, R(p.u) = \frac{R[\Omega]}{R_{base}[\Omega]}, L(p.u) = \frac{L[H]}{L_{base}[H]}$$

278 The unit value of the active resistance of the magnetic circuit R_m it is based on the
279 indicated power S_n [VA] and the nominal winding voltage 1 [1, 27]. Energy Block (PSB)
280 converts flux vectors p.u. and current vectors p.u. into standard units to be used in the
281 saturation model:

$$\Phi = \Phi_{pu} \Phi_{base}, \Phi_{pu} = \Phi / \Phi_{base}, I = I_{pu} I_{base}, I_{pu} = I / I_{base}$$

282

283 where the base values of flux and current are those corresponding to the nominal voltage,
284 power and frequency.

285 *Coil parameters 1 and 2*: Nominal effective voltage value in [V], resistance and driving
286 inductance of the coil 1 in p.u.

287 In *Linear Transformer Block*, measured are: Coil voltage $U_1 = U_p = U_{N1}(pu)$,
288 $U_2 = U_s = U_{N2}(pu)$, Coil current I_{N1} , I_{N2} , Magnetism current I_{mag} and Flux Φ .

289 *Three-phase power transformer data SIMENS Yyn*: (length, width, height
290 1140x800x1700[mm]), rated power $S_n = 160$ [kVA], loses in iron $P_{Fe} = 500$ [W], loses in
291 copper $P_{cun} = 3.2$ [kW], no-load current $i_o \cong 1\%$, short circuit voltage $u_k \cong 3,75\%$,

$$292 \quad V_{np} = V_{n1} = 10.5 \text{ [kV]}, \quad V_{ns} = V_{n2} = 0.4 \text{ [kV]}, \quad R_{base} = \frac{V_n^2}{S_n} = \frac{10.5^2 \cdot 10^6}{160 \cdot 10^3} = 689 \text{ [\Omega]}$$

$$293 \quad L_{base} = \frac{R_{base}}{2\pi f_n} = \frac{689}{314} = 2.194 \text{ [H]}.$$

294 From the primary side of the short-circuit reactance is:

$$295 \quad X_k = \frac{u_k \% V_{1n}^2}{100 S_n} = \frac{3.75 \cdot 10.5^2 \cdot 10^6}{100 \cdot 160 \cdot 10^3} \cong 25.8 \text{ [\Omega]}$$

296 The ratio of the number of turns of the primary and secondary windings is:

$$297 \quad k_t = \frac{U_{1n}}{U_{2n}} = \frac{10.5}{0.230} = 45.652 \cong 46$$

298 The reactance and leakage inductance of the primary winding is:

$$299 \quad X_{k1} = \frac{X_k}{2} = \frac{25.8}{2} \cong 12.9 \text{ [\Omega]}$$

$$300 \quad L_1 = L_{\gamma 1} = \frac{X_{k1}}{\omega} = \frac{12.9}{314} \cong 0.043 \text{ [H]}, \quad L_{1pu} = L_{2pu} = \frac{L_1}{L_{base}} \cdot \frac{0.043}{2.194} \cong 0.02$$

301 The magnetizing impedance is:

$$302 \quad Z_m \cong X_m = \frac{V_{1n} V_{1n}}{\sqrt{3} \cdot i_o \% I_n V_{1n}} = \frac{V_{1n}^2}{i_o S_n} = \frac{10.5^2 \cdot 10^6}{0.01 \cdot 160 \cdot 10^3} = 68.9 \text{ [k}\Omega\text{]}$$

303 The magnetizing inductance on primary side is:

$$304 \quad L_m = \frac{X_m}{\omega} = \frac{68.9 \cdot 10^3}{314} = 219.36 \text{ [H]}, \quad L_{1pu} = \frac{L_m}{L_{base}} = \frac{0.043}{2.194} \cong 0.02$$

305 The resistance of the primary winding is:

$$306 \quad R_1 = R_p = R_{1k} = \frac{1 P_{cun}}{2 \cdot 3 I_{1n}^2} = \frac{1 P_{cun}}{2 S_n^2} V_{1n}^2 = \frac{1 \cdot 3200}{2 \cdot 160^2 \cdot 10^6} \cdot 10.5^2 \cdot 10^6 \cong 6.89 \text{ [\Omega]}$$

$$307 \quad R_{1pu} = R_{2pu} = \frac{R_1}{R_{base}} = \frac{6.89}{689} \cong 0.01$$

308

309 **6. SIMULATION MODEL, SIMULATION DIAGRAMS AND RESULTS**

310

311 For the demonstration and verification of the new model and algorithm of transient
312 processes, a special program was adapted in MATLAB Simulink *psbphaseline31.mdl* [28].

313 The simulation of transient process has replaced the classical method (calculation and
314 measurement) and provides a picture of behavior of three-phase line which is equivalent to
315 distributed parameters or Π scheme.

316 Based on the nominal data of transformer (nominal power, nominal voltages, transformer
317 coupling) and data obtained from short-circuit and no-load tests (short-circuit voltage, short-

318 circuit loss power, no-load current, no-load loss power) electrical parameters of the
 319 transformer can be calculated. In the scheme, both line variants were used: on the upper part,
 320 line variant with distributed parameters, and on the lower part Π line scheme where the
 321 energy transformer in both cases has the same parameters, figure 4.

322 A three-phase powered transformer with the following characteristics was used: ONAN, Yyn
 323 160 [kVA], (10.5)/0.4 [kV] from the source 50 [Hz]. Parameters of winding 1 (primary):
 324 $10.5 \cdot 10^{-3}$ Vrms, $R=0.01$ p.u., $L=0.02$ p.u., parameters of winding 2 (secondary): $0.4 \cdot 10^{-3}$
 325 Vrms/sqrt(3), $R=0.01$ p.u., $L=0.02$ p.u., active losses in the magnetic circuit: $R_m=100$ p.u.
 326 The input values corresponding to the dialog box are:

$$327 \quad R_{1pu} = \frac{6.89}{689} = 0.01 \text{ p.u.}, \quad L_{1pu} = \frac{0.043}{2.194} \cong 0.02 \text{ p.u.}$$

328 A short circuit is simulated with the set secondary current:

$$329 \quad I_n'' = \frac{S_n}{\sqrt{3}V_n} = \frac{160 \cdot 10^3}{\sqrt{3} \cdot 0.4 \cdot 10^3} = 232 \text{ [A]}$$

330 The parameters of the scheme elements are given in the figure 4 (line-SCOPY1,2
 331 SCOPY9,10), and simulation diagrams of currents and voltages in figure 5 and 6.
 332

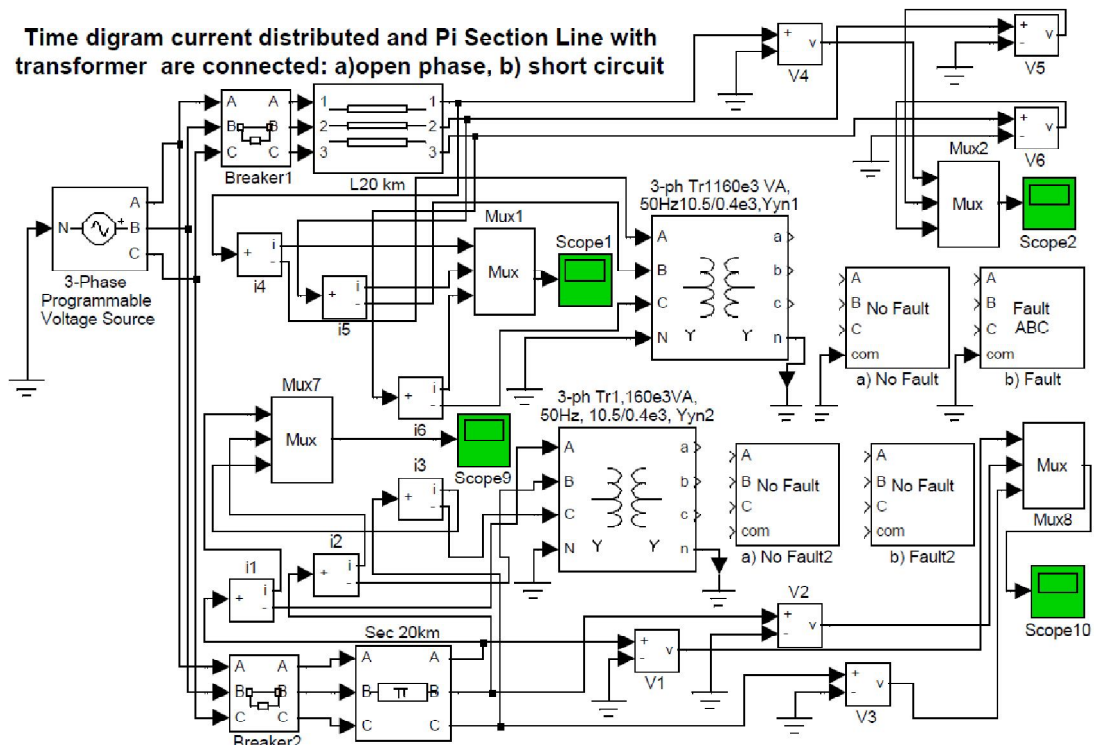

333
 334

Fig. 4. Simulation scheme of extreme modes: a) idling, b) short circuit

336 *Process simulation.* The simulation consists of two parts: in the first part, a short circuit of a
 337 three-phase power transformer is simulated, where the currents and voltages of the primary
 338 set according to the nominal current are controlled. A short circuit was achieved on the
 339 secondary, which was the goal of this part of the simulation. In the second part, the idling
 340 of the three-phase power transformer is simulated. In that case, the secondary current is equal
 341 to zero.

342 We can conclude that in this simulation, the process representing the extreme mode of the
 343 transformer shows the influence of the characteristics of the selected transmission line
 344 scheme. The process is influenced by the parameters of the source, the scheme of lines,

345 primary and secondary and the parameters of the magnetic circuit of the transformer.
 346 Although the forms of currents and voltages on the primary of the transformer are slightly
 347 different, they can affect the sensitive equipment in the relay protection of the power
 348 network.
 349 The resulting forms of currents and voltages presented in figure 5 for a short circuit of a
 350 three-phase power transformer simulated on line with distributed parameters and line with a
 351 Π scheme show that there is an insignificant difference in the levels and forms of the
 352 currents, but also essential differences in the levels and forms of the voltage, due to the
 353 significant presence of harmonics in voltages.
 354

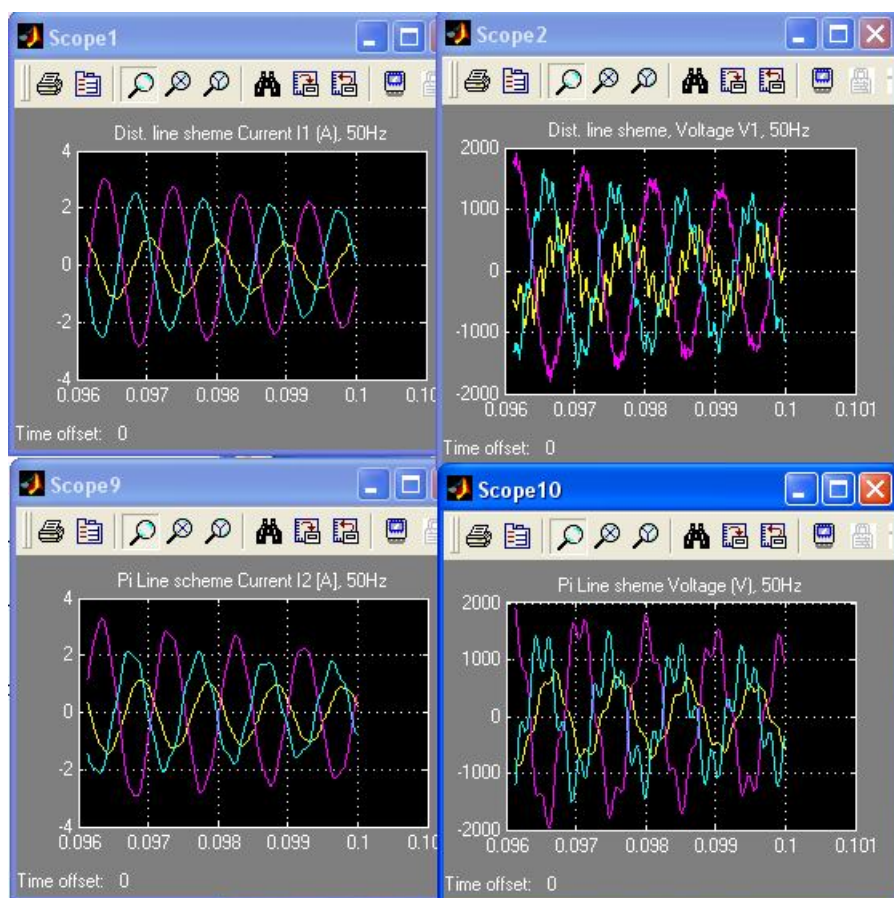

355
 356
 357 **Fig. 5. Current and voltage diagrams - short circuit of a three-phase power**
 358 **transformer: line with distributed parameters and line with Π scheme**
 359
 360 In figure 6, where the idling of a three-phase power transformer on line with distributed
 361 parameters and line with Π scheme is simulated, a slight difference in the level and form of
 362 currents and voltages, as well as a small presence of harmonics in currents and voltages.
 363

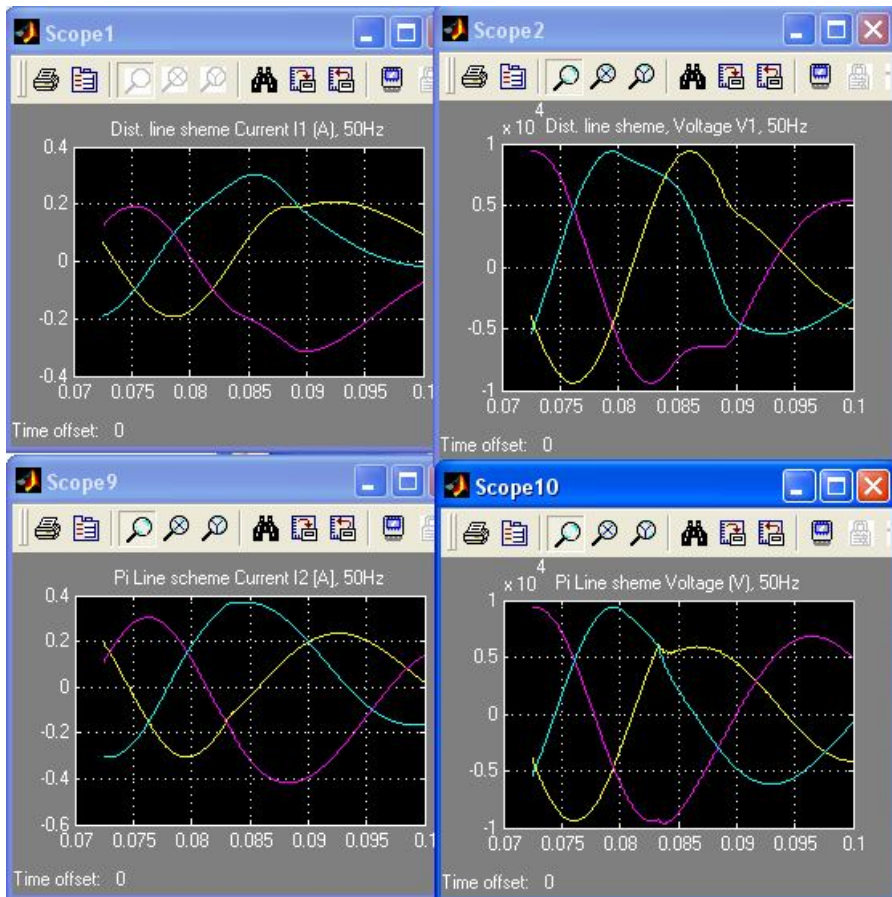

364
 365
 366
 367
 368
 369
 370
 371
 372
 373
 374
 375
 376
 377
 378
 379
 380
 381
 382
 383
 384
 385
 386
 387

Fig. 6. Diagrams of currents and voltages - no-load operation of a three-phase power transformer: line with distributed parameters and line with Π scheme

The advantages of MATLAB are a large number of possible simulations, and the results of those simulations, the shapes and characteristic values of the obtained diagrams of currents and voltages in no-load and short-circuit verify the proposed method for modeling extreme regimes on line with distributed parameters and Π the wiring diagram to which the three-phase power transformer is connected.

7. CONCLUSION

By applying computer simulation of dynamic behavior of power transformer in the software package MATLAB Simulink psbphaseline31.mdl in transient processes, the reliability of the theoretical model in extreme modes such as idling and short circuit of the transformer when the three-phase line is replaced by an equivalent circuit with distributed parameter or with Π scheme.
 On the example of an electrical network in which the power transformer is in one variant connected to a line with distributed parameters, and in the other to a line with Π the scheme with parameters of the same values shows that computer simulation can describe transient processes in the electrical network in a quality way and thus enable better analysis of the behavior of one of the power elements, in this case the power transformer.

388 **COMPETING INTERESTS**

389

390 Authors have declared that no competing interests exist.

391

392 **AUTHORS' CONTRIBUTIONS**

393

394 This work was carried out in collaboration between all authors. Authors N. Marković and S.
395 Bjelić designed the paper, wrote the first version of the paper, managed the literature search
396 and performed the technical preparation of the paper. Authors F. Marković and U. Jakšić has
397 conducted statistic analysis and simulation in the MATLAB program package. All authors
398 read and approved the final manuscript.

399

400 **REFERENCES**

401

402 1. Jakšić U. Marković N. Management of elements of power systems: Kraljevo; 2019.

403 2. Rajaković N. Tasić D. Distribution and industrial networks. Belgrade: Academic thought;
404 2008.

405 3. Fortescue CL. Method of symmetrical co-ordinates applied to the solution of polyphase
406 networks. Trans. Amer. Inst. Electr. Engrs. June 1918.

407 4. Abetti PA. Transformer Models for The Determination of Transient Voltages. Transformers
408 ATEE. 1953;3(72).

409 5. Vidović P. Calculations of power flows of unbalanced distribution networks. Doctoral
410 dissertation. Faculty of Technical Sciences. University in Novi Sad. Novi Sad. Serbia. 2015.
411 Available: <http://www.ftn.uns.ac.rs/n1502063261/disertacija>

412 6. Bjelić S. Prlinčević B. Marković N. Milenković N. Comparison of schemes with distributed
413 parameters and Π scheme of circuits that are closed by nonlinear inductance. 27th
414 Telecommunications forum TELFOR 2019;434-437. Available:
415 <https://ieeexplore.ieee.org/document/8971145/metrics#metrics>

416 7. Gill P. Electrical power equipment maintenance and testing second edition. 2nd ed. CRC
417 Press: Taylor & Francis Group, 2008. Available:
418 https://www.academia.edu/33236618/Electrical_Power_Equipment_Maintenance_and_Testing_2nd_Edition

419 8. Вольдек АИ. Электрические машины. Ленинградское отделение. Энергия; 1974.

420 9. Bergeron L. 'Du coup de Belier en hydraulique au coup de foudre en electricite's (Dunod,
421 1949). (English translation: 'Water Hammer in hydraulics and wave surges in electricity'.
422 ASME Committee. New York: Wiley; 1961.).

423 10. Fitzgerald AE. Kingsley C. Umans SD. Electric Machinery. Fifth Edition. New York:
424 McGraw-Hill Publishing Company; 1990.

425 11. Bjelić S. Bogičević Z. Milenković N. Analysis of the influence of the inductional character
426 elements on the reduction of harmonics. 25th Telecommunications Forum TELFOR
427 2017;410-413. Available: <https://ieeexplore.ieee.org/document/8249373>

428 12. Match LW. Morgan JD. Electromagnetic and Electromechanical Machines. Third Edition.
429 New York: Harper&Row Publishers; 1986.

430 13. Chapman SJ. Electric Machinery Fundamentals. Fourth Edition. New York: McGraw Hill;
431 2005.

432 14. Bogičević Z. Development of algorithms and simulation of transitional process in
433 transformer windings with computer supports. Doctoral Dissertation. Belgrade; 2016.
434 Available: <https://singipedia.singidunum.ac.rs/izdanje/42342-razvoj-algoritma-i-simulacija-tranzientnih-procesa-u-namotajima-transformatora-uz-podrsku-racunara>.

435

436 15. Petrović M. Testing of electrical machines. Belgrade: Academic thought; 2000. Available:
437 <https://kupdf.net/download/2000-m-petrovi-ispitivanje-elektrinih-maina-5968b3b2dc0d602b6ca88e79-pdf>

438

- 441 16. Mitraković B. Testing of electrical machines. Belgrade: Scientific book; 1991.
- 442 17. Jakšić U. Marković N. Živanić J. Milenković N. Development of the Model for Simulation
- 443 of Transient Processes in Cables and Power Lines. Original Research Article. 2018;25(6):1-
- 444 10. Available: <https://journalcjast.com/index.php/CJAST/article/view/1366>
- 445 18. Bogičević Z. Bjelić S. Spalević P. Mišić M. Graph-Analytical Method of Determining
- 446 Impedance in Electrical Transformers. Mathematical Problems in Engineering. Vol. 2015,
- 447 Article ID 745629. 2015. Available:
- 448 <https://www.hindawi.com/journals/mpe/2015/745629/#references>
- 449 19. Rajaković N. Analysis of power systems II. Belgrade: Academic thought; 2008.
- 450 20. Magnusson PC. Weisshaar A. Tripathi VK. Alexander GC. Transmission Lines and Wave
- 451 Propagation. CRC Press. London, New York, Washington DC.: Boca Ration; 2017.
- 452 21. Nahman J. Mijailović V. Switchgear. Faculty of Electrical Engineering. Belgrade:
- 453 Academic thought; 2005.
- 454 22. Đurić M. High voltage plants. Belgrade: Beopres print; 2009.
- 455 23. Mišić M. Bogičević Z. Bjelić S. Electrodynamical Forces between Electrical Conductors
- 456 and Cylindrical Magnetic Shields. Review Article. 2015;11(4):1-11. Available:
- 457 <https://journalcjast.com/index.php/CJAST/article/view/144>
- 458 24. Günter GS. Siemens. Electrical Installation Handbook. 2nd Edition. Publicis; 1987.
- 459 25. Bjelić S. Protection Techniques in Electrical Energy Networks. Kvar: Kraljevo; 2018.
- 460 26. Pansini AJ. Electrical Transformers and Power Equipment. The Farmont Press. Lilburn.
- 461 Ga. USA. 3rd edition; 1999.
- 462 27. Veverka A. Technika visokih napeti. SNTL/ALFA DT 621.3.027.3.621.315.21. Praha;
- 463 1982.
- 464 28. MATLAB Simulink SimPowerSystem. Copyright 2002 TheMathWorks. Version
- 465 6.5.0,180913a.
- 466