

Idling and short-circuit analysis of a three-phase power transformer represented by a scheme with distributed parameters and Π line scheme in the electrical network

ABSTRACT

Aims: The paper presents a simulation of a theoretical model of electromagnetic extreme regimes, idling and short circuit, in a three-phase power transformer. The main goal of this paper is to show in a quality way that the computer simulation of the obtained theoretical model using the software package MATLAB Simulink confirms the possibility of analyzing the extreme modes of transformers.

Methodology: To solve the problem of the presence of a transformer as an element of power in the power system, the following are used: analytical methods in which the transformer is presented as a network element - usually as a quadripole, numerical programming that includes dynamic programming and independent variables, and combined programming with integer values. In the process simulation on elements with given parameters and frequency, a comparison of the substitution schemes used so far in the theory of electric circuits is performed. The accuracy of these theoretical models can be confirmed by voltage and current diagrams in the adapted software package MATLAB Simulink.

Conclusion: The presented theoretical model and the applied algorithm in the simulation are universal and can be used for different states in which a three-phase power transformer can be found. Problems that occur in the analysis of transient processes in electrical networks where the element is a transformer can be minimized using simulation methods. Changing any parameter in the electrical circuit requires a new calculation of the condition of the circuit from the very beginning due to the new initial conditions. Analytical methods combined with the simulation method were used in the research of extreme regimes, such as idling and short circuit. The verified simulation method realized using the adapted MATLAB Simulink program had a three fold purpose: to serve the calculation and simulation of quantities that can be obtained by testing or measuring, to establish the original algorithm and to verify the proposed method. Also, this type of simulation can replace the idle and short circuit test.

Keywords: Simulation, model, electrical network, three-phase power transformer, power line, quadripole

1. INTRODUCTION

Preparation of computer programs in the method of organized modeling is called pre-processing in the technical literature (formation of technical system models). Modeling is a mathematical, graphic, IT and technical operation intended for analysis and evaluation of various variants of electrical structure.

Processes in devices with complex geometry due to the content of a large number of sub-areas with various electrical, magnetic and conductive properties are solved using network methods whose modification is the final element method, FEM (Rica, Galerkina, etc.). The

essence of method is in testing approximations of solutions of differential equations with a finite number of linear combinations of forms of basic functions [1]. The form of the base function and criteria for calculating coefficients of linear combinations also defines a method of finding a solution.

There are cable lines in distribution network (underground lines with insulated conductors), overhead lines with uninsulated (bare) conductors and overhead lines with insulated conductors in small number of cases [2]. In the past, experiments or network analyzers have been used to analyze transient processes in electrical networks containing power sources, lines and power elements (transformers or arbitrary electrical loads) [3,4]. These procedures were very complex in nature and without a real answer to influence of parameters of the network elements on process character. Today, parameters given in the domain of symmetric components are mainly used for calculation of line parameters [5-7].

In this paper, the Π and T line scheme was used to determine the quadripole coefficients. Behavior of a three-phase power transformer connected to an electric line represented by a scheme with distributed parameters and a Π scheme of lines in the electric network was also analyzed. With help of the MATLAB Simulink software package, a simulation with short-circuit and idle diagrams of a three-phase power transformer was presented.

2. OVERVIEW OF RELEVANT PAPERS

The beginning of transformers development is connected with appearance and transmission of alternating current. The first transformers are result of work of a Russian engineer PN. Jablov, then L. Goulard and JD. Gibbsa, as well as SZ. de Ferrary and W. Stanley.

The theory of single-phase and three-phase machines and transformers was developed in the first half of the XX century: АИ. ПА. Abeti [4], Вольдек [8], Bergeron [9], Fitzgerald [10] are just some of the names of hundreds of engineers and scientists who have published papers in the field of machines and transformers. In the available literature, only the fundamental harmonic is taken into account in analysis of normal and transient states, and method of symmetrical components is most often used for the analysis. However, new contributions were made by Match [11] and Chapman [12], who in their works mainly analyze normal stationary states with one frequency and classical transformer parameters.

In the early papers and books of the past 100 years, most of the problems and parameters of electricity quality have been neglected because issue of electricity quality has not been of great importance. Today, most of applied transformers have high values of power and voltage, which imposes problem of determining higher harmonics (not only the fundamental) voltage and current and their distribution along the windings.

3. ANALYSIS OF THE NETWORK ELEMENT MODEL AS A QUADRIPOLES

Quadripoles are used in the theory of electric circuits to model elements such as lines, transformers, powerful electrical receivers, etc. Transformers can be modeled as electrical elements of electrical networks Π , Γ , vice-versa Γ or T schemes [13,14].

If the line element has distributed parameters, it is represented by a quadripoles model and more easily considers the wave character of energy transfer through that part [15,16]. Voltages, currents and power flow at the inlet or outlet of line are determined from the equivalent scheme. According to the method of Kirchhoff's rules for voltages in contours:

$$\sum (V_k - Z_k I_k) = 0 \quad (1)$$

and currents in the nodes:

$$\sum (I_i) = 0 \quad (2)$$

and provided that in the outer part of the circuit current I_1 and voltage V_1 at the output and current I_2 and voltage V_2 at the output they remain the same in amplitude and argument

beyond the ends 1-1' and 2-2' quadripoles, figure 1.a one can realize the transfiguration of the structure from a triangle to a star and vice versa within the nodes 1, 2, 1'=3(0), 2'=3(0) and following relations, figure 1.b and 1.c:

$$\begin{aligned} Z_1 &= \frac{Z_{12}Z_{31}}{Z_{12} + Z_{23} + Z_{31}} = \frac{Y_{23}}{Y_{12}Y_{23} + Y_{23}Y_{31} + Y_{31}Y_{12}}, & Z_{12} &= Z_1 + Z_2 + \frac{Z_1Z_2}{Z_3} = \frac{Y_1 + Y_2 + Y_3}{Y_1Y_2} \\ Z_2 &= \frac{Z_{12}Z_{23}}{Z_{12} + Z_{23} + Z_{31}} = \frac{Y_{31}}{Y_{12}Y_{23} + Y_{23}Y_{31} + Y_{31}Y_{12}}, & Z_{23} &= Z_2 + Z_3 + \frac{Z_2Z_3}{Z_1} = \frac{Y_1 + Y_2 + Y_3}{Y_2Y_3} \\ Z_3 &= \frac{Z_{23}Z_{31}}{Z_{12} + Z_{23} + Z_{31}} = \frac{Y_{12}}{Y_{12}Y_{23} + Y_{23}Y_{31} + Y_{31}Y_{12}}, & Z_{31} &= Z_3 + Z_1 + \frac{Z_3Z_1}{Z_2} = \frac{Y_1 + Y_2 + Y_3}{Y_3Y_1} \end{aligned} \quad (3)$$

Quadripole with current I_1 and voltage V_1 on the input and current I_2 and voltage V_2 on the output is presented on the figure 1.a (the linear quadripole has no independent sources and the circuit has no converted energy). Independent parameters of the internal structure are immittances (impedances Z and/or admittance Y). Quadripoles are used to analyze the transmission of energy on lines [17]. A couple of ends (1-1') represents the entrance, and a couple of ends (2-2') the quadripole output is reserved for the receiver connection. The analysis of quadripoles determines the expressions that connect voltages, currents and powers in selected branches between input and output quantities. An arbitrary quadripole with two pairs of ends, figure 1.a, regardless of the internal structure is represented by $\Pi(\Delta)$ scheme, figure 1.b and 1.d and $T(Y)$ scheme, figure 1.c and 1.e [2].

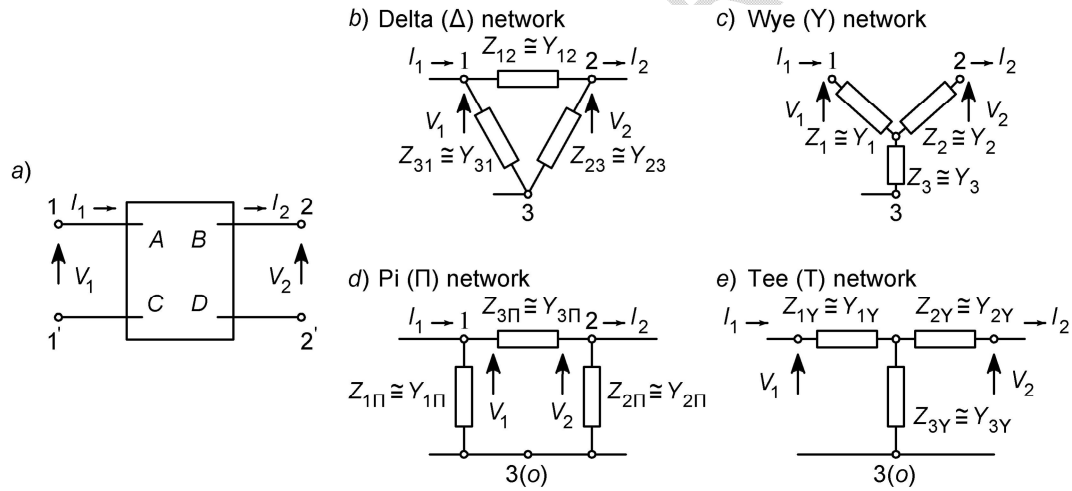

Fig. 1. a) Quadripole scheme, b) and d) $\Pi(\Delta)$ scheme, c) and e) $T(Y)$ scheme

For $\Pi(\Delta)$ scheme on figure 1.b and 1.d with impedance $Z_{1\Pi}$, $Z_{2\Pi}$, $Z_{3\Pi}$ (or agreeable admittance $Y_{1\Pi}$, $Y_{2\Pi}$, $Y_{3\Pi}$) following equations applied for:

$$\text{Voltage: } V_1 = \left(I_2 + \frac{V_2}{Z_{2\Pi}} \right) Z_{3\Pi} + V_2 = \left(1 + \frac{Z_{3\Pi}}{Z_{2\Pi}} \right) V_2 + Z_{3\Pi} I_2 = AV_2 + BI_2 \quad (4)$$

where: $A = 1 + \frac{Z_{3\Pi}}{Z_{2\Pi}}$, $B = Z_{3\Pi}$,

$$\text{Current: } I_1 = \frac{V_1}{Z_{1\Pi}} + \frac{V_2}{Z_{2\Pi}} + I_2 = \left(\frac{1}{Z_{1\Pi}} + \frac{1}{Z_{2\Pi}} + \frac{Z_{3\Pi}}{Z_{1\Pi}Z_{2\Pi}} \right) V_2 + \left(1 + \frac{Z_{3\Pi}}{Z_{1\Pi}} \right) I_2 = CV_2 + DI_2 \quad (5)$$

$$\text{where: } C = \left(\frac{1}{Z_{1\Pi}} + \frac{1}{Z_{2\Pi}} + \frac{Z_{3\Pi}}{Z_{1\Pi}Z_{2\Pi}} \right), D = \left(1 + \frac{Z_{3\Pi}}{Z_{1\Pi}} \right).$$

For T(Y) scheme on figure 1.c and 1.e with impedance Z_{1Y}, Z_{2Y}, Z_{3Y} (or ageable admittance Y_{1Y}, Y_{2Y}, Y_{3Y}) we can write following equations for:

$$\text{Current: } I_1 = I_2 + I_3 = I_2 + \frac{V_2 + Z_{2Y}I_2}{Z_{3Y}} = \frac{1}{Z_{3Y}}V_2 + \left(1 + \frac{Z_{2Y}}{Z_{3Y}} \right) I_2 = CV_2 + DI_2 \quad (6)$$

$$\text{where: } C = \frac{1}{Z_{3Y}}, D = 1 + \frac{Z_{2Y}}{Z_{3Y}},$$

$$\begin{aligned} \text{Voltage: } V_1 &= Z_{1Y}I_1 + Z_{2Y}I_2 + V_2 = \left[\frac{1}{Z_{2Y}}V_2 + \left(1 + \frac{Z_{2Y}}{Z_{3Y}} \right) I_2 \right] Z_{1Y} + Z_{2Y}I_2 + V_2 = \\ &= \left(1 + \frac{Z_{1Y}}{Z_{3Y}} \right) V_2 + \left(Z_{1Y} + Z_{2Y} + \frac{Z_{1Y}Z_{2Y}}{Z_{3Y}} \right) I_2 = AV_2 + BI_2 \end{aligned} \quad (7)$$

$$\text{where: } A = 1 + \frac{Z_{1Y}}{Z_{3Y}}, B = Z_{1Y} + Z_{2Y} + \frac{Z_{1Y}Z_{2Y}}{Z_{3Y}}.$$

Based on the previous relations, it is shown that the two internal schemes differ only in admittances $Y_{1\Pi}, Y_{2\Pi}, Y_{3\Pi}$ and Y_{1Y}, Y_{2Y}, Y_{3Y} .

There is a dependence between the coefficients of the quadripole A, B, C and D and in both schemes $AD - BC = 1$, which is checked by equation:

$$\left(1 + \frac{Z_{3\Pi}}{Z_{2\Pi}} \right) \left(1 + \frac{Z_{3\Pi}}{Z_{1\Pi}} \right) - Z_{3\Pi} \left(\frac{1}{Z_{1\Pi}} + \frac{1}{Z_{2\Pi}} + \frac{1}{Z_{1\Pi}} \right) = 1 \quad (8)$$

The coefficients can be determined by means of derived relations or experimentally from the no-load or short-circuit test if the input and output ends of quadripole are accessible. This is very important when the internal structure of quadripole is unknown [18]. In the continuation of this paper, the influence of choice of the type of line scheme (distributed parameters and Π scheme) on values and shapes of the obtained currents and voltages was examined.

4. STATE OF ELECTRIC LINE PRESENTED BY SCHEME WITH DISTRIBUTED PARAMETERS AND Π SCHEME

Transmission lines are also shown as four-terminals with combined z - and y -parameters, and its structure is Π or T scheme. From these schemes we move on to the characteristics that represent the mode of transmission described by the parameters of intrinsic or mutual conductivity (admittances y) or resistances (impedances z) [18-20].

The no-load test is performed under condition that the no-load voltage corresponds to rated voltage of receiver at the ends 2-2' $V_2 = V_{20} = V_{2n}$, and a short circuit test to short circuit current $I_2 = I_{2sh.c}$ corresponds to rated current of receiver at the ends 2-2' when the structure of a quadripole is a combination of Y, Z parameters: $Z_{1\Pi} \cong Y_{1\Pi}, Z_{2\Pi} \cong Y_{2\Pi}, Z_{3\Pi} \cong Z_{1\Pi}$, figure 2.a,b [6].

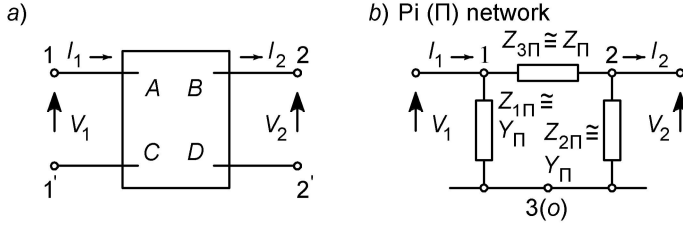

Fig. 2. a) Quadripole scheme, b) Π line scheme

As we have already said, a line is an element with distributed parameters, and the selected model contains parameters (per unit length for total length). The unit longitudinal parameters are: $R = r \cdot l$, $L_p = l_p \cdot l$, $G = g \cdot l$ and $C = c \cdot l$.

Transformation from equations of finite differences into equations with integral-differential form is possible. The influence of the ferromagnetic material of the magnetic circuit and the processes in it have not been the subject of attention here. All line parameters are linear, so the principle of superposition can be applied.

If the line is presented as a circuit with concentrated parameters, the wave character of long lines should be considered. The solution of the transient process in a single-phase line with distributed parameters is:

$$\begin{aligned} V_1 &= ch\gamma_0 l \cdot V_2 + Z_c sh\gamma_0 l \cdot I_2 \\ I_1 &= \frac{1}{Z_c} sh\gamma_0 l \cdot V_2 + ch\gamma_0 l \cdot I_2 \end{aligned} \quad (9)$$

The parameters of the replacement scheme of long lines if the line is presented as a quadripole are:

$$\begin{aligned} V_1 &= A \cdot V_2 + \sqrt{3} B \cdot I_2 \\ I_1 &= (1/\sqrt{3}) C \cdot V_2 + D \cdot I_2 \end{aligned} \quad (10)$$

where are the coefficients of the quadripole $A = ch\gamma_0 l$, $B = Z_c sh\gamma_0 l$, $C = \frac{1}{Z_c} sh\gamma_0 l$,

$$D = ch\gamma_0 l.$$

If the line introduces it self with Π scheme and considers idle mode regime in Π scheme at the end of the line, then the following expressions are obtained:

$$\begin{aligned} A &= \frac{V_1}{I_1} \Big|_{I_2=0}, V_1 = V_2 + Z_{\Pi} Y_{\Pi} \cdot V_2 \\ I_1 &= \frac{Y_{\Pi}}{\sqrt{3}} V_1 + \frac{1}{\sqrt{3} \left(Z_{\Pi} + \frac{1}{Y_{\Pi}} \right)} V_1 = \frac{1}{\sqrt{3}} \left(Y_{\Pi} + \frac{Y_{\Pi}}{1 + Z_{\Pi} Y_{\Pi}} \right) \cdot V_1 \\ I_1 &= \frac{V_2}{\sqrt{3}} (1 + Z_{\Pi} Y_{\Pi}) \left(Y_{\Pi} + \frac{Y_{\Pi}}{1 + Z_{\Pi} Y_{\Pi}} \right) = \frac{1}{\sqrt{3}} (2Y_{\Pi} + Z_{\Pi} Y_{\Pi}^2) \cdot V_2 \end{aligned} \quad (11)$$

For quadripole in idle mode presented with Π scheme at the end of the line, we get:

$$\begin{aligned} V_1 &= A \cdot V_2 \\ I_1 &= C \cdot V_2 / \sqrt{3} \end{aligned} \quad (12)$$

where: $A = \frac{V_1}{I_1} \Big|_{I_2=0} = 1 + Z_{\Pi} Y_{\Pi}$, $C = 2Y_{\Pi} + Z_{\Pi} Y_{\Pi}^2$.

If line is presented with Π scheme and if short circuit mode in Π scheme at the end of the line is considered, following expressions are obtained:

$$V_1 = \sqrt{3} \cdot Z_{\Pi} \cdot I_2$$

$$I_1 = \frac{1}{\sqrt{3}} \cdot V_1 \left(\frac{1}{Z_{\Pi}} + Y_{\Pi} \right) = \frac{\sqrt{3} Z_{\Pi} I_2}{\sqrt{3}} \left(\frac{1 + Z_{\Pi} Y_{\Pi}}{Z_{\Pi}} \right) = (1 + Z_{\Pi} Y_{\Pi}) \cdot I_2 \quad (13)$$

Analog relations for quadripole in the short-circuit mode presented with Π scheme at the end of the line are:

$$V_1 = \sqrt{3} \cdot B \cdot I_2$$

$$I_1 = D \cdot I_2 \quad (14)$$

where: $B = Z_{\Pi}$, $D = (1 + Z_{\Pi} Y_{\Pi}) = A$.

Relations that connect constants and parameters are:

$$ch \gamma_o l = A = 1 + Z_{\Pi} Y_{\Pi}, \quad ch \gamma_o l = D = (1 + Z_{\Pi} Y_{\Pi}) = A$$

$$Z_c sh \gamma_o l = B = Z_{\Pi}, \quad \frac{1}{Z_c} sh \gamma_o l = C = 2 Y_{\Pi} + Z_{\Pi} Y_{\Pi}^2 \quad (15)$$

It is natural that uncompensated transmission line is a symmetrical quadripole because it is $ch \gamma_o l = D = (1 + Z_{\Pi} Y_{\Pi}) = A$. From relations (15) values are easily determined for Z_{Π} , Y_{Π} , Π line shemes:

$$Z_{\Pi} = Z_c sh \gamma_o l = \sqrt{\frac{Z_o}{Y_o}} sh \gamma_o l = \sqrt{\frac{Z_o l}{y_o l}} sh \gamma_o l = Z_o l \frac{sh \gamma_o l}{\gamma_o l} = Z_o l K_s$$

$$Y_{\Pi} = \frac{\gamma_o l}{2} \frac{1}{Z_c} \frac{2}{\gamma_o l} th \left(\frac{\gamma_o l}{2} \right) = \frac{\sqrt{Z_o Y_o}}{\sqrt{Z_o / Y_o}} \frac{l}{2} \frac{th \left(\frac{\gamma_o l}{2} \right)}{\left(\frac{\gamma_o l}{2} \right)} = Y_o \frac{1}{2} K_y \quad (16)$$

Correction coefficients K_s and K_y which take into account the distribution of parameters along the line (Ceneli coefficients) are:

$$K_s = k_s \angle \varphi_s = \frac{sh \gamma_o l}{\gamma_o l} = \frac{sh \sqrt{Z_o Y_o} \cdot l}{\sqrt{Z_o Y_o} \cdot l}$$

$$K_y = k_y \angle \varphi_s = \frac{th \left(\frac{\gamma_o l}{2} \right)}{\frac{\gamma_o l}{2}} = \frac{th \left(\frac{l}{2} \sqrt{Z_o Y_o} \right)}{\frac{l}{2} \sqrt{Z_o Y_o}} \quad (17)$$

Nomograms for determining correction coefficients K_s and K_y [1] are:

$$K_s = \frac{sh \gamma_o l}{\gamma_o l}, \quad K_y = \frac{th \left(\frac{\gamma_o l}{2} \right)}{\frac{\gamma_o l}{2}} \quad (18)$$

and are determined by first determining modulus and value argument $Z_o Y_o l^2$ where Z_o and Y_o are longitudinal impedances and admittances, and l length of energy transmission line. K_s and K_y are determined from the nomogram if the inequality condition is met

$$|Z_o Y_o l^2| \leq 0.36 \quad [2].$$

If the correction coefficients cannot be determined directly from the nomogram due to $|Z_o Y_o l^2| > 0.36$ the following procedure can be used:

$$\sqrt{Z_0 Y_0} l = \sqrt{ZY} = \Phi, \quad \sqrt{Z_0 Y_0} \frac{l}{2} = \frac{1}{2} \sqrt{ZY} = \psi \Leftrightarrow \Phi = 2\psi \quad (19)$$

Correction coefficients for long lines l [km] can be determined according to:

$$K_s = \frac{sh\gamma_0 l}{\gamma_0 l} = \frac{sh\sqrt{ZY}}{\sqrt{ZY}} = \frac{sh\Phi}{\Phi} = \frac{sh2\psi}{2\psi} = \frac{2sh\psi \cdot ch\psi}{2\psi} = \frac{sh\psi}{\psi} ch\psi \Leftrightarrow K_{s,l/2} = K_{s,l/2} ch \frac{\sqrt{ZY}}{2}$$

$$K_s = \frac{th \frac{\sqrt{ZY}}{2}}{\frac{\sqrt{ZY}}{2}} = \frac{sh \frac{\sqrt{ZY}}{2}}{\frac{\sqrt{ZY}}{2}} \frac{1}{ch \frac{\sqrt{ZY}}{2}} \Leftrightarrow K_{y,l} = K_{y,l/2} \frac{1}{ch \frac{\sqrt{ZY}}{2}} \quad (20)$$

From the relation (20) it is clear that the correction coefficients of the parameters of the replacement equivalent schemes of lines of 1000 [km] length are calculated by multiplying two terms, each of which characterizes a line of length $l/2$ and the modulus and complex-valued argument can be specified $|Z_0 Y_0 l^2|/4$.

The complex value of the line constant A of length l , is determined as:

$$A = ch\sqrt{ZY} = ch2 \frac{\sqrt{ZY}}{2} = ch^2 \frac{\sqrt{ZY}}{2} + sh^2 \frac{\sqrt{ZY}}{2} = 2ch^2 \frac{\sqrt{ZY}}{2} - 1 \Leftrightarrow A_l = 2A_{l/2}^2 - 1 \quad (21)$$

where constant A can be determined from the nomogram.

4.1. Characteristics of Π scheme of lines

According to the previously derived relations, it is possible to determine the parameters of lines with distributed parameters or equivalent Π scheme of lines. Calculation results are presented in table 1.

Table 1. Determination of lines parameters

l [km]	$Z_{\Pi} = r_{\Pi} + jx_{\Pi}$ [Ω]	$y_{\Pi} 10^{-4} = (g_{\Pi} + jb_{\Pi}) 10^{-4}$ [Ω^{-1}]	$A = D, B = Z_{\Pi}, C 10^{-4}$ [Ω^{-1}]
500	6.21+j134.2	0.014+j10.98	0.852 +j0.007 -0.051+j20.35
1000	8.68+j227.3	0.136+j23.87	0.454 +j0.024 -0.372+j34.69

Marks in the table 1 are: r_{Π} active resistance, $x_{\Pi} = j\omega \cdot l_i$ reactance, g_{Π} conductance $b_{\Pi} = j\omega \cdot c$ susceptance.

A, B, C and D are parameters of the open circuit for they are determined as relation of voltage and current with opened output (current $I_2 = 0$) or input (current $I_1 = 0$) and are:

$$A = \frac{V_1}{I_1} \Big|_{I_2=0} = ch\sqrt{zy}l, B = \frac{V_1}{I_2} \Big|_{I_1=0} = Z_c sh\sqrt{zy}l$$

$$C = \frac{V_2}{I_1} \Big|_{I_2=0} = \frac{1}{Z_c} sh\sqrt{zy}l, D = \frac{V_2}{I_2} \Big|_{I_1=0} = A = ch\sqrt{zy}l \quad (22)$$

4.2. Replacement diagrams for lines and cables

In the theory of electrical circuits, the quadripole is defined by the diagram in figure 3 and the equations:

$$U_1 = AU_2 + BI_2, \quad I_1 = CU_2 + DI_2 \quad (23)$$

or matrix:

$$\begin{bmatrix} U_1 \\ I_1 \end{bmatrix} = \begin{bmatrix} A & B \\ C & D \end{bmatrix} \begin{bmatrix} U_2 \\ I_2 \end{bmatrix} \quad (24)$$

In line case coefficients A , B , C and D have the following values:

$$A = ch\sqrt{ZY}, B = Z_c sh\sqrt{ZY}, C = 1/Z_c sh\sqrt{ZY}, D = A = ch\sqrt{ZY} \quad (25)$$

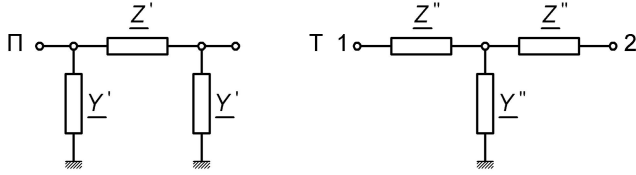

Fig. 3. Quadripole of T and Π shape that represents the line

Quadripole most frequently has the form of T or Π scheme where coefficients A , B , C and D can be easily determined. It can be described with equation system:

$$\underline{Z}' = \underline{B}, \underline{Y}' = \underline{A} + 1/\underline{B}, \underline{Z}'' = \underline{A} - 1/\underline{C}, \underline{Y}'' = \underline{C} \quad (26)$$

$$\underline{Z}' = \sqrt{\underline{Z}/\underline{Y}} sh\sqrt{\underline{ZY}} = \underline{z}l \frac{sh\sqrt{\underline{ZY}}}{\sqrt{\underline{ZY}}} = \underline{z}lK_1 = \underline{Z}K_1 \quad (27)$$

$$\underline{Y}' = \frac{ch\sqrt{\underline{ZY}}^{-1}}{\sqrt{\underline{Z}/\underline{Y}} sh\sqrt{\underline{ZY}}} = \frac{1}{\sqrt{\underline{Z}/\underline{Y}}} th\sqrt{\underline{ZY}/2l} = \frac{\underline{Y}l}{2} \frac{th\sqrt{\underline{ZY}/2l}}{\sqrt{\underline{ZY}/2l}} = \frac{\underline{Y}l}{2} K_2$$

$$\underline{Z}'' = \frac{ch\sqrt{\underline{ZY}} - 1}{1/\sqrt{\underline{ZY}} sh\sqrt{\underline{ZY}}} = \sqrt{\underline{ZY}} th\sqrt{\underline{ZY}/2l} = \underline{Z}l/2 \frac{th\sqrt{\underline{ZY}/2l}}{\sqrt{\underline{ZY}/2l}} = \frac{\underline{Z}l}{2} K_2 \quad (28)$$

$$\underline{Y}'' = 1/\sqrt{\underline{Z}/\underline{Y}} sh\sqrt{\underline{ZY}} = \underline{Y}l \frac{sh\sqrt{\underline{ZY}}}{\sqrt{\underline{ZY}}} = \underline{Y}lK_1 = \underline{Y}K_1$$

K_1 and K_2 are the coefficients introduced in network analysis by Kennelly.

Correction factors that can be calculated by a relatively complex procedure are:

$$\begin{aligned} ch(\alpha + j\beta) &= ch\alpha chj\beta + sh\alpha shj\beta = ch\alpha ch\beta + sh\alpha sh\beta \\ sh(\alpha + j\beta) &= sh\alpha chj\beta + ch\alpha shj\beta = sh\alpha \cos\beta + jch\alpha \sin\beta \end{aligned} \quad (29)$$

$$sh\alpha = \sum_{k=0}^{\infty} \frac{\alpha^{(2k+1)}}{(2k+1)!} = \alpha + \alpha^3/3! + \dots, ch\alpha = \sum_{k=0}^{\infty} \frac{\alpha^{2k}}{2k!} = 1 + \alpha^2/2$$

α and β depend on line parameters, α and β are small values and formulas for calculations are obtained by Rudenberg's procedure.

The value of the coefficient K_1 is:

$$K_1 = \frac{sh\sqrt{\underline{ZY}}}{\sqrt{\underline{ZY}}} \approx 1/\sqrt{\underline{ZY}} \left(\sqrt{\underline{ZY}} + \frac{(\sqrt{\underline{ZY}})^3}{3!} \right) \quad (30)$$

By introducing parameters $\lambda = \sqrt{bx}l$, i.e. factor $\rho = r/x$ we get: $K_1 = 1 - \lambda^2/6 + j\rho\lambda^2/6$.

The same procedure is used to derive the expression for K_2 and we get:

$$K_2 = \frac{th\sqrt{\underline{ZY}}/2}{\sqrt{\underline{ZY}}/2} \approx \frac{1}{\sqrt{\underline{ZY}}/2} \left(\frac{\sqrt{\underline{ZY}}}{2} - \frac{(\sqrt{\underline{ZY}}/2)^3}{3} \right), K_2 = 1 - \lambda^2/12 - j\rho\lambda^2/12 \quad (31)$$

In case the line does not produce reactive power $q \approx 0$, $\sqrt{\underline{ZY}} = \sqrt{(r + jx)jb} = j\lambda\sqrt{1 - j\rho}$ then coefficients K_1 and K_2 :

$$K_1 = j \frac{\sin \lambda \sqrt{1 - j\rho}}{j\lambda \sqrt{1 - j\rho}}, K_2 = \frac{j \operatorname{tg} \lambda \sqrt{1 - j\rho} / 2}{j\lambda \sqrt{1 - j\rho} / 2} \quad (32)$$

Values K_1 and K_2 are developed in a series by ρ and an equation is obtained in which they are correction factors:

$$K_1 \approx \sin \lambda / \lambda - j\rho / 2(\cos \lambda - \sin \lambda / \lambda), K_2 \approx \frac{\operatorname{tg} \lambda}{\lambda / 2} + j\rho / 2 \frac{\sin \lambda / \lambda - 1}{\cos^2 \lambda / 2} \quad (33)$$

$$\begin{aligned} \operatorname{Re}\{Z'\} &= r \operatorname{Re}\{K_1\} - x \operatorname{Im}\{K_1\} = r[\operatorname{Re}\{K_r'\} - 1 / \rho \operatorname{Im}\{K_1\}] \\ \operatorname{Im}\{Z'\} &= r \operatorname{Im}\{K_1\} + x \operatorname{Re}\{K_1\} = x[\operatorname{Re}\{K_x'\} + \rho \operatorname{Im}\{K_1\}] \end{aligned} \quad (34)$$

Below are the line parameters with distributed parameters and Π line scheme, as well as the parameters of the three-phase power transformer SIMENS Yyn [21] that are used in simulation.

5. PARAMETERS OF BOTH VARIANTS OF LINES AND TRANSFORMERS

5.1. Parameters of both lines types

In accordance with technical practice, the resistance and inductance of the coils in the per unit system should be determined (p.u.).

For this simulation with frequency $f = 50$ [Hz], both equivalent circuit schemes were used, namely: circuit with distributed parameters and Π scheme line.

Identical parameters are used:

Same length (length=20 [km]),

Line 1 Distributed = Line 2Pi,

3 phase A, B, C: $r_{1,2} = 0.01273$ [Ω/km], $r_0 = 0.2546$ [Ω/km],

$l_{1,2} = 0.93377 \cdot 10^{-3}$ [H/km], $l_0 = 18.66 \cdot 10^{-3}$ [H/km],

$c_{1,2} = 12.74 \cdot 10^{-9}$ [F/km], $c_0 = 0.637 \cdot 10^{-9}$ [F/km].

5.2. Transformer parameters

Transformer model in the MATLAB Simulink program package was implemented so that its inputs are the source voltage vectors and the parameters of source and winding of transformer, and the outputs are the flux vectors, magnetizing currents and variable unit values of the primary and secondary voltages [1,22,23]. Simulation and analysis of behavior of transformer in extreme regimes during transient process was carried out for no load and short circuit, and consists of described simulation models of voltage and parameters of source of lines and transformer.

Base values are rated power S_n [VA], rated frequency f_n [Hz], rated voltage V_n [V], effective power value V_{rms} , as well as:

$$R_{base} = \frac{[V_n]^2}{S_n}, L_{base} = \frac{R_{base}}{2\pi f_n}, R(p.u.) = \frac{R[\Omega]}{R_{base}[\Omega]}, L(p.u.) = \frac{L[H]}{L_{base}[H]}$$

The unit value of the active resistance of the magnetic circuit R_m it is based on the indicated power S_n [VA] and the nominal winding voltage 1 [1,24]. Energy Block (PSB)

converts flux vectors p.u. and current vectors p.u. into standard units to be used in the saturation model:

$$\Phi = \Phi_{pu} \Phi_{base}, \quad \Phi_{pu} = \Phi / \Phi_{base}, \quad I = I_{pu} I_{base}, \quad I_{pu} = I / I_{base}$$

where the base values of flux and current are those corresponding to the nominal voltage, power and frequency.

Coil parameters 1 and 2: Nominal effective voltage value in [V], resistance and driving inductance of the coil 1 in p.u.

In *Linear Transformer Block*, measured are: Coil voltage $U_1 = U_p = U_{N1}(pu)$, $U_2 = U_s = U_{N2}(pu)$, Coil current I_{N1} , I_{N2} , Magnetism current I_{mag} and Flux Φ .

Three-phase power transformer data SIMENS Yyn: (length, width, height 1140x800x1700[mm]), rated power $S_n = 160$ [kVA], loses in iron $P_{Fe} = 500$ [W], loses in copper $P_{cun} = 3.2$ [kW], no-load current $i_o \cong 1\%$, short circuit voltage $u_k \cong 3,75\%$,

$$V_{np} = V_{n1} = 10.5 \text{ [kV]}, \quad V_{ns} = V_{n2} = 0.4 \text{ [kV]}, \quad R_{base} = \frac{V_n^2}{S_n} = \frac{10.5^2 \cdot 10^6}{160 \cdot 10^3} = 689 \text{ [\Omega]}$$

$$L_{base} = \frac{R_{base}}{2\pi f_n} = \frac{689}{314} = 2.194 \text{ [H]}.$$

From the primary side of the short-circuit reactance is:

$$X_k = \frac{u_k \% V_{1n}^2}{100 S_n} = \frac{3.75 \cdot 10.5^2 \cdot 10^6}{100 \cdot 160 \cdot 10^3} \cong 25.8 \text{ [\Omega]}$$

The ratio of the number of turns of the primary and secondary windings is:

$$k_t = \frac{U_{1n}}{U_{2n}} = \frac{10,5}{0.230} = 45.652 \cong 46$$

The reactance and leakage inductance of the primary winding is:

$$X_{k1} = \frac{X_k}{2} = \frac{25.8}{2} \cong 12.9 \text{ [\Omega]}$$

$$L_1 = L_{\gamma 1} = \frac{X_{k1}}{\omega} = \frac{12.9}{314} \cong 0.043 \text{ [H]}, \quad L_{1pu} = L_{2pu} = \frac{L_1}{L_{base}} = \frac{0.043}{2.194} \cong 0.02$$

The magnetizing impedance is:

$$Z_m \cong X_m = \frac{V_{1n} V_{1n}}{\sqrt{3} \cdot i_o \% I_n V_{1n}} = \frac{V_{1n}^2}{i_o S_n} = \frac{10.5^2 10^6}{0.01 \cdot 160 \cdot 10^3} = 68.9 \text{ [k}\Omega\text{]}$$

The magnetizing inductance on primary side is:

$$L_m = \frac{X_m}{\omega} = \frac{68.9 \cdot 10^3}{314} = 219.36 \text{ [H]}, \quad L_{1pu} = \frac{L_m}{L_{base}} = \frac{0.043}{2.194} \cong 0.02$$

The resistance of the primary winding is:

$$R_1 = R_p = R_{1k} = \frac{1 P_{cun}}{2 \cdot 3 I_{1n}^2} = \frac{1 P_{cun}}{2 S_n^2} V_{1n}^2 = \frac{1 \cdot 3200}{2 \cdot 160^2 10^6} 10.5^2 10^6 \cong 6.89 \text{ [\Omega]}$$

$$R_{1pu} = R_{2pu} = \frac{R_1}{R_{base}} = \frac{6.89}{689} \cong 0.01$$

6. SIMULATION MODEL, SIMULATION DIAGRAMS AND RESULTS

For the demonstration and verification of the new model and algorithm of transient processes, a special program was adapted in MATLAB Simulink *psbphaseline31.mdl* [25]. The simulation of transient process has replaced the classical method (calculation and

measurement) and provides a picture of behavior of three-phase line which is equivalent to distributed parameters or Π scheme.

Based on the nominal data of transformer (nominal power, nominal voltages, transformer coupling) and data obtained from short-circuit and no-load tests (short-circuit voltage, short-circuit loss power, no-load current, no-load loss power) electrical parameters of the transformer can be calculated. In the scheme, both line variants were used: on the upper part, line variant with distributed parameters, and on the lower part Π line scheme where the energy transformer in both cases has the same parameters, figure 4.

A three-phase powered transformer with the following characteristics was used: ONAN, Yyn 160 [kVA], (10.5)/0.4 [kV] from the source 50 [Hz]. Parameters of winding 1 (primary): $10.5 \cdot 10^{-3}$ Vrms, $R=0.01$ p.u., $L=0.02$ p.u., parameters of winding 2 (secondary): $0.4 \cdot 10^{-3}$ Vrms/sqrt(3), $R=0.01$ p.u., $L=0.02$ p.u., active losses in the magnetic circuit: $R_m=100$ p.u. The input values corresponding to the dialog box are:

$$R_{1pu} = \frac{6.89}{689} = 0.01 \text{ p.u.}, \quad L_{1pu} = \frac{0.043}{2.194} \cong 0.02 \text{ p.u.}$$

A short circuit is simulated with the set secondary current:

$$I_n'' = \frac{S_n}{\sqrt{3}V_n} = \frac{160 \cdot 10^3}{\sqrt{3} \cdot 0.4 \cdot 10^3} = 232 \text{ [A]}$$

The parameters of the scheme elements are given in the figure 4 (line-SCOPY1,2 SCOPY9,10), and simulation diagrams of currents and voltages in figure 5 and 6.

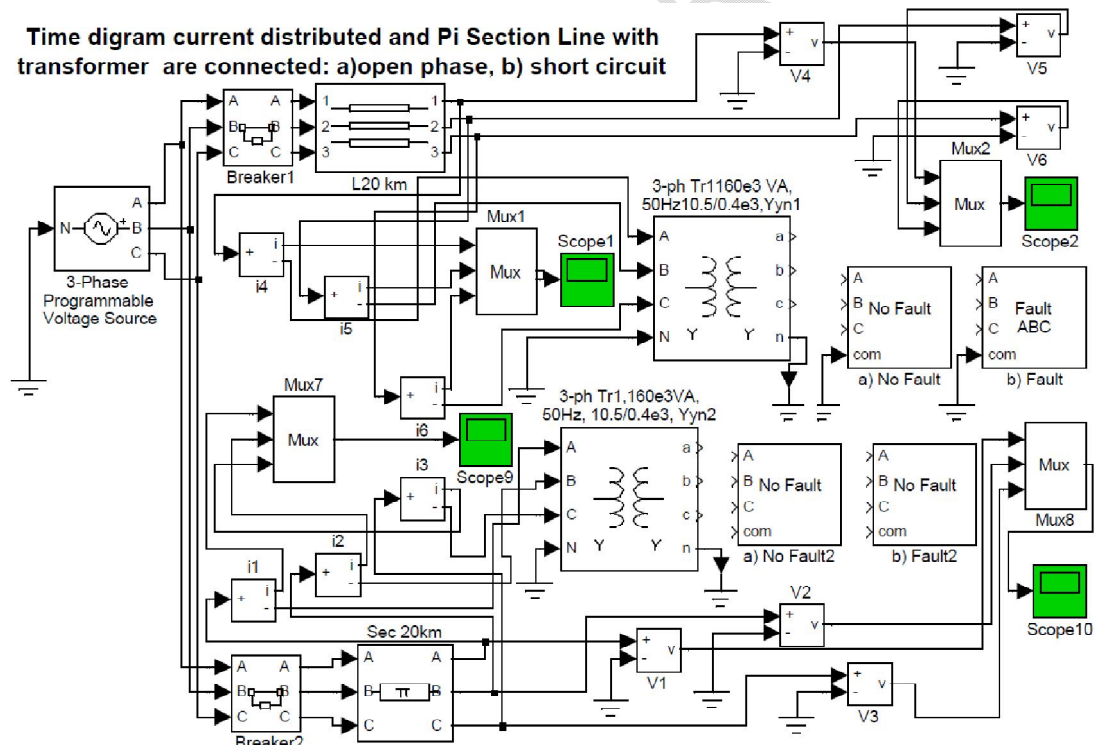

Fig. 4. Simulation scheme of extreme modes: a) idling, b) short circuit

Process simulation. The simulation consists of two parts: in the first part, a short circuit of a three-phase power transformer is simulated, where the currents and voltages of the primary set according to the nominal current are controlled. A short circuit was achieved on the secondary, which was the goal of this part of the simulation. In the second part, the idling of

the three-phase power transformer is simulated. In that case, the secondary current is equal to zero.

We can conclude that in this simulation, the process representing the extreme mode of the transformer shows the influence of the characteristics of the selected transmission line scheme. The process is influenced by the parameters of the source, the scheme of lines, primary and secondary and the parameters of the magnetic circuit of the transformer. Although the forms of currents and voltages on the primary of the transformer are slightly different, they can affect the sensitive equipment in the relay protection of the power network.

The resulting forms of currents and voltages presented in figure 5 for a short circuit of a three-phase power transformer simulated on line with distributed parameters and line with Π scheme show that there is an insignificant difference in the levels and forms of the currents, but also essential differences in the levels and forms of the voltage, due to the significant presence of harmonics in voltages.

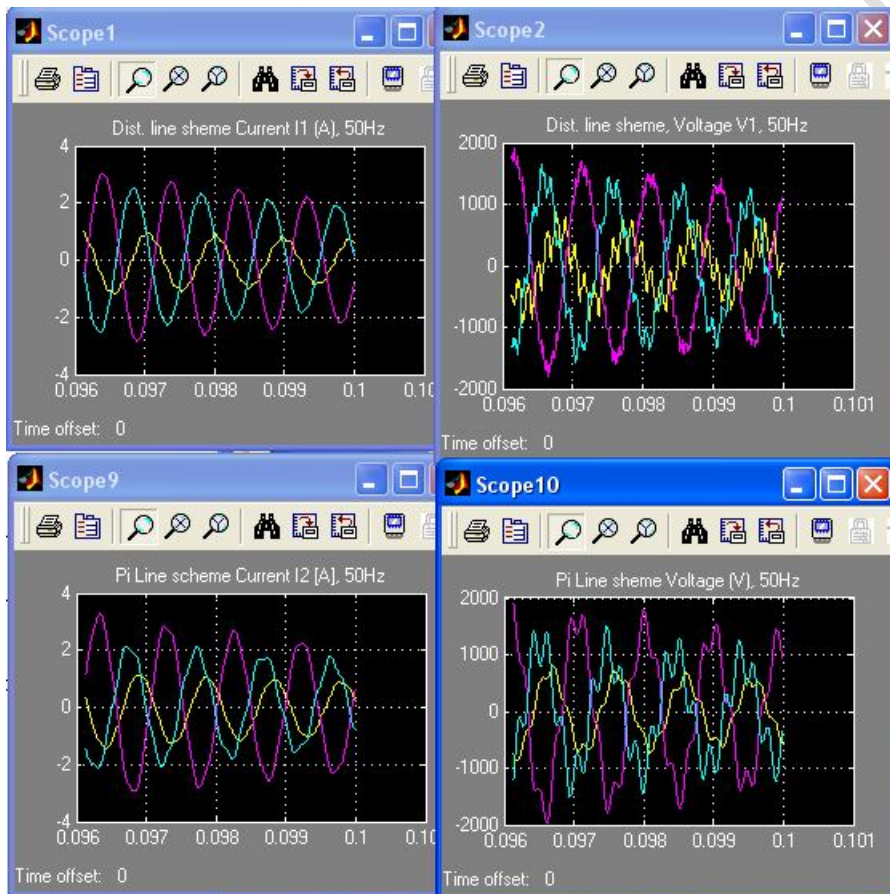

Fig. 5. Current and voltage diagrams - short circuit of a three-phase power transformer: line with distributed parameters and line with Π scheme

In figure 6, where the idling of a three-phase power transformer on line with distributed parameters and line with Π scheme is simulated, a slight difference in the level and form of currents and voltages, as well as a small presence of harmonics in currents and voltages.

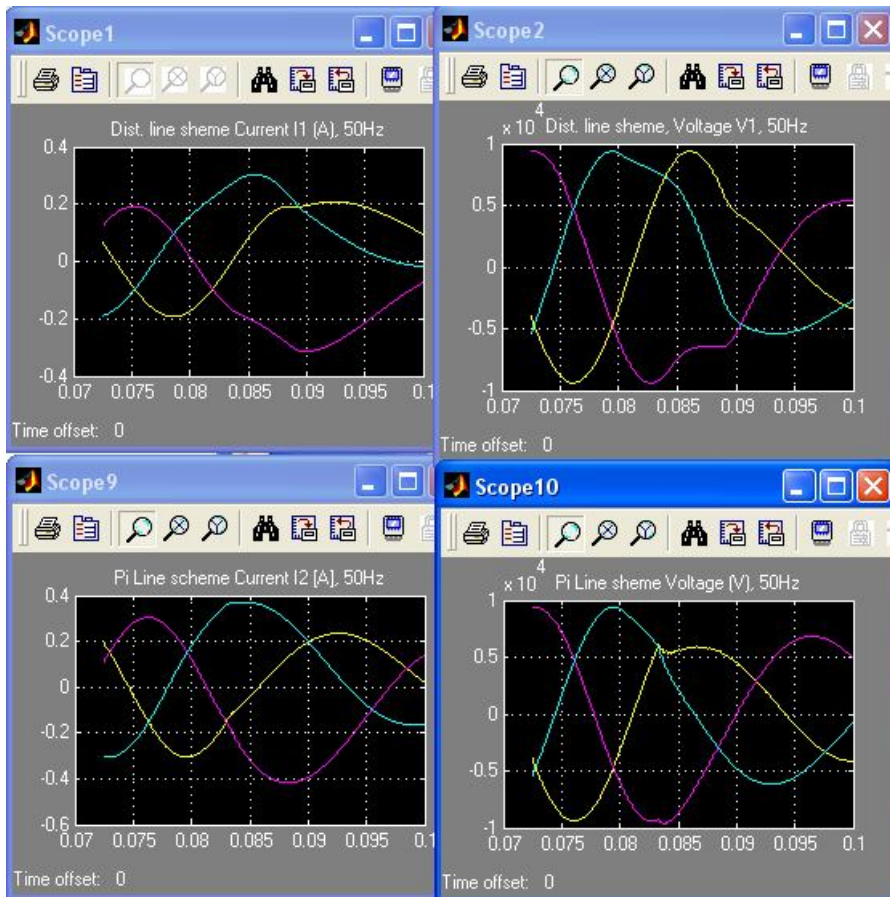

Fig. 6. Diagrams of currents and voltages - no-load operation of a three-phase power transformer: line with distributed parameters and line with Π scheme

The advantages of MATLAB are a large number of possible simulations, and the results of those simulations, the shapes and characteristic values of the obtained diagrams of currents and voltages in no-load and short-circuit verify the proposed method for modeling extreme regimes on line with distributed parameters and Π the wiring diagram to which the three-phase power transformer is connected.

7. CONCLUSION

By applying computer simulation of dynamic behavior of power transformer in the software package MATLAB Simulink psbphaseline31.mdl in transient processes, the reliability of the theoretical model in extreme modes such as idling and short circuit of the transformer when the three-phase line is replaced by an equivalent circuit with distributed parameter or with Π scheme.

On the example of an electrical network in which the power transformer is in one variant connected to a line with distributed parameters, and in the other to a line with Π the scheme with parameters of the same values shows that computer simulation can describe transient processes in the electrical network in a quality way and thus enable better analysis of the behavior of one of the power elements, in this case the power transformer.

REFERENCES

1. Jakšić U. Marković N. Management of elements of power systems: Kraljevo; 2019.
2. Rajaković N. Tasić D. Distribution and industrial networks. Belgrade: Academic thought; 2008.
3. Fortescue CL. Method of symmetrical co-ordinates applied to the solution of polyphase networks. Trans. Amer. Inst. Electr. Engrs. June 1918.
4. Abetti PA. Transformer Models for The Determination of Transient Voltages. Transformers ATEE. 1953;3(72).
5. Vidović P. Calculations of power flows of unbalanced distribution networks. Doctoral dissertation. Faculty of Technical Sciences. University in Novi Sad. Novi Sad. Serbia. 2015. Available: <http://www.ftn.uns.ac.rs/n1502063261/disertacija>
6. Bjelić S. Prlinčević B. Marković N. Milenković N. Comparison of schemes with distributed parameters and Π scheme of circuits that are closed by nonlinear inductance. 27th Telecommunications forum TELFOR 2019;434-437. Available: <https://ieeexplore.ieee.org/document/8971145/metrics#metrics>
7. Gill P. Electrical power equipment maintenance and testing second edition. 2nd ed. CRC Press: Taylor & Francis Group, 2008. Available: https://www.academia.edu/33236618/Electrical_Power_Equipment_Maintenance_and_Testing_2nd_Edition
8. Вольдек АИ. Электрические машины. Ленинградское отделение. Энергия; 1974.
9. Bergeron L. 'Du coup de Belier en hydraulique au coup de foudre en electricite's (Dunod, 1949). (English translation: 'Water Hammer in hydraulics and wave surges in electricity'. ASME Committee. New York: Wiley; 1961.).
10. Fitzgerald AE. Kingsley C. Umans SD. Electric Machinery. Fifth Edition. New York: McGraw-Hill Publishing Company; 1990.
11. Match LW. Morgan JD. Electromagnetic and Electromechanical Machines. Third Edition. New York: Harper&Row Publishers; 1986.
12. Chapman SJ. Electric Machinery Fundamentals. Fourth Edition. New York: McGraw Hill; 2005.
13. Petrović M. Testing of electrical machines. Belgrade: Academic thought; 2000. Available: https://kupdf.net/download/2000-m-petrovi-ispitivanje-elektrinih-maina_5968b3b2dc0d602b6ca88e79_pdf
14. Mitraković B. Testing of electrical machines. Belgrade: Scientific book; 1991.
15. Jakšić U. Marković N. Živanić J. Milenković N. Development of the Model for Simulation of Transient Processes in Cables and Power Lines. Original Research Article. 2018;25(6):1-10. Available: <https://www.journalcjust.com/index.php/CJAST/article/view/9696>
16. Bogićević Z. Bjelić S. Spalević P. Mišić M. Graph-Analytical Method of Determining Impedance in Electrical Transformers. Mathematical Problems in Engineering. Vol. 2015, Article ID 745629. 2015. Available: <https://www.hindawi.com/journals/mpe/2015/745629/#references>
17. Rajaković N. Analysis of power systems II. Belgrade: Academic thought; 2008.
18. Magnusson PC. Weisshaar A. Tripathi VK. Alexander GC. Transmission Lines and Wave Propagation. CRC Press. London, New York, Washington DC.: Boca Ration; 2017.
19. Nahman J. Mijailović V. Switchgear. Faculty of Electrical Engineering. Belgrade: Academic thought; 2005.
20. Đurić M. High voltage plants. Belgrade: Beopres print; 2009.
21. Günter GS. Siemens. Electrical Installation Handbook. 2nd Edition. Publicis; 1987.
22. Bjelić S. Protection Techniques in Electrical Energy Networks. Kvar: Kraljevo; 2018.
23. Pansini AJ. Electrical Transformers and Power Equipment. The Farmont Press. Lilburn. Ga. USA. 3rd edition; 1999.
24. Veverka A. Technika visokih napeti. SNTL/ALFA DT 621.3.027.3.621.315.21. Praha; 1982.

25. MATLAB Simulink SimPowerSystem. Copyright 2002 TheMathWorks. Version 6.5.0,180913a.

UNDER PEER REVIEW