

Original Research Article

Simulation Studies on Recovery of Acetonitrile from Aqueous Acetonitrile waste from Pharmaceutical Processes

Abstract

This paper presents simulation studies on the recovery of Acetonitrile from aqueous Acetonitrile waste from pharmaceutical processes. The focus is on atmospheric distillation in two sequential columns to understand the separation feasibility of the system; the first column produces a distillate of azeotropic composition, which is mixed with a fresh stream and fed to a second column, which produces a 99.9 % pure Acetonitrile in the residue. The effect of reflux ratio, reboiler duty and the fresh stream flowrate on the purity of the product is analyzed. The study was performed using steady state simulator Aspen Plus, version 11.1. The simulation results indicate that it is possible to obtain a product of 99.9 % w/w Acetonitrile from a 1:1 feed with a recovery of ~ 60%.

Keywords: Distillation, Simulation, Acetonitrile, Aspen Plus, Sensitivity Analysis.

Introduction

Acetonitrile is one of the important solvents primarily used in the pharmaceutical industries, due to its medium polarity and the miscibility with water. The effluents from the processes involving Acetonitrile as solvent mostly consists of a binary mixture of Acetonitrile and water; it is important and ample opportunities are available for recovering Acetonitrile from the aqueous

waste streams [1]. Acetonitrile can be recovered using distillation depending on the initial composition of the binary mixture. The feed composition is important because the Acetonitrile-water forms an azeotropic mixture at 83 % Acetonitrile under atmospheric conditions.

Distillation is a mass transfer operation which separates two or more components into two streams which are more concentrated in one of the components. The separation is based on the relative volatility of the components in the feed stream. The overhead product, called as the distillate can be collected as a vapor or a liquid and is rich in more volatile component(s). The residue collected from the bottom of the column consists of the less volatile or the low boiling components.

Configuration of the column, feed composition, process conditions and target purity of the desired product are major factors that affect a distillation operation. The column configuration can be specified in terms of the total theoretical stages and feed location, where as the operating parameters that influence the performance of a column include reflux ratio, boil-up ratio, condenser and reboiler heat duty.

It is important to understand the effect of these variables on the desired product purity and the throughput from the system. Simulation studies provide relevant and significant results corresponding to the variation of any operation/process with respect to factors effecting them. It is safe, inexpensive and consumes less time than experimental effort in understanding the system under study.

Literature Review

There are a few papers published related to the simulation studies on distillation of binary mixtures [2]–[5]. Lone and Rather [2] have performed simulation studies of a distillation column for the separation of 1:1 Methanol-water system. The objective of the study was to find optimum feed stage location, total number of stages and the optimum reflux ratio to obtain 99.5% pure methanol in distillate and 99.5% pure water in the residue. Aspen plus simulation software was used. Lone and Akhlaq [3] have developed a rigorous model for the simulation of the steady-state behavior of the distillation column, solving the

model using MATLAB, they have presented the effect of feed condition and the feed composition on the steady state behavior of a distillation column for separation of Methanol-MTBE-Isobutylene. With Isopropyl Alcohol-Water system as case study, Yadav et al [4] have performed steady state and dynamic simulations using Aspen Plus, to depict the behavior of the system. They have presented the concept of degrees of freedom, variables effect and systematic working procedure of Aspen Plus and simulated the effect on mole fraction of liquid phase, vapor phase with changes in temperature, pressure, activity coefficients, respectively. Shorey [5] have presented a comparative study on simulation of distillation column for methanol-water system using DWSIM and ASPEN Plus. The author focused on providing the insights on the obstacles faced in simulations carried out using an open source software.

Separation of Acetonitrile-Water mixtures, is often performed using membrane separation techniques[6]–[9], extractive and azeotropic distillation[10]–[12] and pressure swing distillation[13]. While membrane separation can be an effective method for separating Acetonitrile-Water mixtures, there are several potential disadvantages in terms of membrane selectivity, cost, degradation, fouling and energy requirements. The azeotropic/extractive distillation involves entrainer/solvent, which causes issues with selectivity, limited separation ability, higher energy consumption and recovery of the entrainer/solvent. Pressure swing distillation offers another promising method for the separation of Acetonitrile-Water mixtures, however it is marred by the high energy consumption, equipment complexity, scalability and process control challenges. Also the rapid pressure changes may create safety concerns.

Materials and Methods

In the present paper, a flowsheet/separation methodology is proposed that uses 2 columns to achieve 99.9 % pure Acetonitrile. The first column produces a stream with azeotropic composition and a fresh stream of Acetonitrile is added to this stream and fed to the second column to obtain 99.9 % pure Acetonitrile. A feed of 50 % w/w of Acetonitrile and 50 % w/w water is considered for separation and simulation studies were performed to understand the separation feasibility of the system and the effect of reflux ratio,

reboiler duty and the fresh stream flowrate on the purity of the product. Steady state simulator Aspen Plus, version 11.1 was used for performing the simulations. It is a commercially available software for the simulations of systems from chemicals, polymers and life sciences industries.

The steps followed were:

- (1) Defined components and selected NRTL thermodynamic model for estimation of physical properties and binary interactions.
- (2) Estimated the properties of the binary system; studied T-xy plot and the variation of the azeotropic composition at varying pressures to understand the optimum vacuum for the distillation.
- (3) Created flowsheet with two sequential columns with RADFRAC model.
- (4) Preliminary simulations were performed.
- (5) Sensitivity analysis was done.

The flow sheet is shown in **Error! Reference source not found.** As the Acetonitrile-water system forms an azeotrope at 83 % w/w of Acetonitrile a single distillation column would not be sufficient to get a purity of > 83 % w/w of Acetonitrile. Thus, the distillate from the first column was sent to mixer where a fresh stream of Acetonitrile was added, and then this mixed stream was fed to a second column. The second column was optimized to yield a distillate containing > 99.5 % w/w of Acetonitrile.

Column Configuration

A series of two columns was considered for the present case study. The first column, COLUMN-1 consists of 10 number of stages and the second column, COLUMN-2 has 15 number of stages. Both the columns are connected to total condensers. The distillate from COLUMN-1 was passed to a mixer, B1 where it is enriched with fresh 99.9 % w/w pure Acetonitrile and fed to a second column, COLUMN-2, to

obtain a residue of ~ 99.9 % w/w from the COLUMN-2. The configuration of both the columns is given in Table 1 and the feed specifications are given in Table 2.

Results and Discussion

The **Error! Reference source not found.** and **Error! Reference source not found.** respectively shows the T-xy and y-x Diagram for the Acetonitrile-water Binary System. Under atmospheric conditions, Acetonitrile-water forms a minimum boiling azeotrope at 83 % w/w of Acetonitrile. The variation of azeotropic composition under vacuum was then evaluated and is shown in Table 3. The data in Table 3 indicates the possibility of obtaining 99 % w/w purity of Acetonitrile in a single distillation set-up under high vacuum of 750 mmHg. However, operating feasibility and the economics of the process has to be considered in detail. The present study is focused on the atmospheric distillation in 2 sequential columns.

Atmospheric distillation of feeds of Acetonitrile and water comprising less than 83 % w/w of Acetonitrile would produce a distillate of maximum purity equal to the azeotropic composition. For this reason, in the present study two columns were considered in series. With an aim of obtaining Acetonitrile greater than 98 % w/w purity, fresh stream of Acetonitrile (99.5 % w/w) was mixed with the distillate obtained from Column-1 and fed to the Column-2. This addition of fresh stream of Acetonitrile, changes the feed composition for the Column-2. The distillation in the second column produces a distillate closer to azeotropic composition and a residue of purer Acetonitrile. The stream results corresponding to the base case simulation are given in Table 4. The recovery of 99.9 % w/w Acetonitrile is 45.8 %. The base column configuration and the operating parameters can be optimized for the desired purity of Acetonitrile.

The temperature and concentration profiles for both the columns are shown in **Error! Reference source not found.****Error! Reference source not found.****Error! Reference source not found.**, **Error! Reference source not found.** and **Error! Reference source not found.**. Column-1 operates at higher temperatures,

when compared to the Column-2 as the water content is higher yielding a higher boiling point for the mixture at every stage. The temperature in both the columns decreases from the reboiler to the first stage. The reboiler of Column-1 is at 353.7 K, whereas the reboiler of Column-2 attains 350 K.

The Vapor composition of Acetonitrile in both the columns is shown in **Error! Reference source not found.** Interestingly, in the Column-2 the vapor composition of Acetonitrile increases towards the bottom of the column, whereas it increases towards condenser in the Column-1. This is because in the Column-1 the separation is between the water and the azeotropic mixture of Acetonitrile and water, while in the second column separation is between the azeotropic mixture and Acetonitrile. The azeotrope formed boils at ~ 350K. The boiling point of Acetonitrile is 355 K and that of water is 373 K. as shown in **Error! Reference source not found.**, the maximum composition of the Acetonitrile obtained from the Column-1 is 83.4 % w/w. **Error! Reference source not found.** shows the variation of composition of Acetonitrile in the liquid in both the columns. It follows a trend similar to the vapor composition profiles; highest mass fraction of the Acetonitrile is seen in the bottom stage of Column-2. Acetonitrile of desired composition is obtained as residue from Column-2.

Sensitivity Analysis

Aspen plus software provides a model analysis tool that facilitates the optimization of the model with respect to the selected variables.

For the COLUMN-1, sensitivity analysis was performed, to optimize the number stages, the location of feed stage and Reflux ratio to maximize the distillate rate.

The variation of distillate rate with total number of stages is shown in **Error! Reference source not found.** The figure shows an increase in distillate rate with an increase in number of stages up to 8 total stages, for a fixed reflux ratio of 1.5. For further increase in number of stages, the distillate rate was observed to be constant at 5.95 kg/hr. Similar trend was found for the variation of the distillate rate with feed stage location; maximum distillate rate is obtained when the feed is provided on stage 6. This plot is shown in **Error! Reference source not found.** The effect of increase in reflux ratio on the distillate rate is shown in **Error! Reference source not found.** The distillate rate was observed to decrease with an increase in the reflux ratio. So a reflux ratio of 1 is chosen as optimum for further simulations.

The mass fraction of Acetonitrile in the residue of Column-2 was chosen as the objective variable and sensitivity was analyzed for the following parameters.

Reflux ratio

Reboiler Duty, and

The amount of fresh Acetonitrile added to mixer to change the feed composition for COLUMN-2.

Error! Reference source not found. shows variation of mass fraction of Acetonitrile with reflux ratio. For this column, the reflux ratio up to 2.5 gives > 99.9% pure acetonitrile, further increase in reflux ratio results in the decrease in the purity of the acetonitrile recovered. The reflux ratio of 1.5 as in the base case simulation is chosen as optimum.

The increase in the reboiler heat load for the Column-2, as shown in **Error! Reference source not found.**, has major effect on the purity of Acetonitrile obtained from the column. A ten fold increase in the reboiler duty enhances the mass fraction from 0.913 to 1. Nevertheless, it is important to study energy efficiency of the column to decide the reboiler heat load. 3960 kCal/hr is chosen as the optimum reboiler duty.

The effect of total number of stages in Column-2 is shown in **Error! Reference source not found.** Increased number of stages increases the purity of residue. At least 10 stages are required to obtain a 99.9 % Acetonitrile. The increase in the fresh feed added to the mixer to change the composition of the feed to Column-2 significantly effects the purity of Acetonitrile obtained. The distillate obtained from the Column-1 is mixed with a stream of 99.5 % w/w Acetonitrile in the Mixer B1 to alter the feed composition to Column-2. Whence, the rate at which the fresh feed is added to mixer has substantial effect on the residue rate as well as composition from the Column-2. This effect of varying feed rate of fresh feed on the residue composition is shown in **Error! Reference source not found.** The residue rate increases and the purity decreases with the increase in feed flow rate. The flow rate then needs to be optimized based on the economics in terms of the yield of the Acetonitrile from the column. The variation of residue rate from Column-2 with the fresh stream flow rate is shown in **Error! Reference source not found.** The residue rate also depends on the reboiler duty.

The composition of the streams with optimized values for reboiler duty and the rate of the Fresh Stream of Acetonitrile to the mixer is given in 5.

Recovery of Acetonitrile

The recovery of Acetonitrile is evaluated from the following equation.

$$\text{Percentage Recovery} = \frac{\text{Amount of Acetonitrile Recovered}}{\text{Amount of Acetonitrile fed to the system}} \times 100 \quad (1)$$

Amount of Acetonitrile recovered will be the quantity of Acetonitrile obtained in the bottoms stream from the COLUMN-2. The denominator term must include Acetonitrile in feed to both the columns.

For the base case simulation, the percentage recovery of Acetonitrile was evaluated to be 45.8 %. For the optimized system, the recovery of 99.9% pure Acetonitrile from the system increased to 60.4 %.

Conclusion

The case study envisaged in the present paper, to recover 99.9 % w/w Acetonitrile from 1:1 aqueous Acetonitrile stream by atmospheric distillation indicates the possibility of recovery using 2 sequential columns. Obtaining azeotropic mixture of acetonitrile-Water from a 50 % w/w mixture is considerably easy and requires a smaller number of stages and less reflux conditions. The second column was optimized for reflux ratio, reboiler duty and amount of fresh feed of Acetonitrile given to the mixer before Column-2 to change the composition of the feed to Column-2. The purity of Acetonitrile obtained from Column-2 was found to be 99.9 % w/w. The recovery of acetonitrile from the proposed optimized set-up increased to 60.4 % from the base case considered for simulation. Further optimization in terms of process economics needs to be done.

References

- [1] I. F. McConvey, D. Woods, M. Lewis, Q. Gan, and P. Nancarrow, "The importance of acetonitrile in the pharmaceutical industry and opportunities for its recovery from waste," *Org. Process Res. Dev.*, vol. 16, no. 4, pp. 612–624, 2012, doi: 10.1021/op2003503.
- [2] S. Rasool Lone and M. Ahmad Rather, "Modeling and Simulation of a Distillation Column using ASPEN PLUS for separating methanol/water mixture," *Int. J. Sci. Eng. Res.*, vol. 6, no. 3, pp. 619–627, 2015, doi: 10.14299/ijser.2015.03.002.
- [3] S. A. A. Sohail Rasool Lone, "Modeling and Simulation of a Distillation Column Using Matlab," *Int. J. Eng. Res. Sci. Technol.*, vol. 2, No.4, no. May, 2013, [Online]. Available: www.ijerst.com.
- [4] E. Sarath Yadav, T. Indiran, D. Nayak, C. Aditya Kumar, and M. Selvakumar, "Simulation study of distillation column using Aspen plus," *Mater. Today Proc.*, vol. 48, no. 2, pp. 330–337, 2022, doi: 10.1016/j.matpr.2020.07.609.

- [5] R. Shorey, "Simulation of Distillation Column using DWSIM and ASPEN Plus: A Comparative Study."
- [6] X. Mei et al., "Acetonitrile wastewater treatment enhanced by a hybrid membrane-aerated bioreactor containing aerated and non-aerated zones," *Bioresour. Technol.*, vol. 289, p. 121754, Oct. 2019, doi: 10.1016/J.BIORTECH.2019.121754.
- [7] M. K. Mandal, S. B. Sant, and P. K. Bhattacharya, "Dehydration of aqueous acetonitrile solution by pervaporation using PVA-iron oxide nanocomposite membrane," *Colloids Surfaces A Physicochem. Eng. Asp.*, vol. 373, no. 1-3, pp. 11-21, Jan. 2011, doi: 10.1016/J.COLSURFA.2010.10.016.
- [8] P. Das and S. K. Ray, "Synthesis of highly water selective copolymer membranes for pervaporative dehydration of acetonitrile," *J. Memb. Sci.*, vol. 507, pp. 81-89, Jun. 2016, doi: 10.1016/J.MEMSCI.2016.02.015.
- [9] Z. Su et al., "Phase behavior and internal micro mechanism of separation acetonitrile from water by hydrophobic green solvents," *J. Environ. Chem. Eng.*, vol. 10, no. 5, p. 108507, Oct. 2022, doi: 10.1016/J.JECE.2022.108507.
- [10] D. Han, Y. Chen, and M. Dong, "Process evaluation for the separation of acetonitrile-water using extractive distillation with deep eutectic solvents as entrainers," *Comput. Chem. Eng.*, vol. 164, p. 107865, Aug. 2022, doi: 10.1016/J.COMPCHEMENG.2022.107865.
- [11] Z. Zhang, B. Dong, Z. Zhang, J. Chen, H. Xin, and Q. Zhang, "Separation of acetonitrile + isopropanol azeotropic mixture using ionic liquids with acetate anion as entrainers," *Fluid Phase Equilib.*, vol. 521, p. 112725, Oct. 2020, doi: 10.1016/J.FLUID.2020.112725.

[12] B. Shan et al., “Control of the azeotropic distillation process for separation of acetonitrile and water with and without heat integration,” Chem. Eng. Process. - Process Intensif., vol. 165, p. 108451, Aug. 2021, doi: 10.1016/J.CEP.2021.108451.

[13] F. Huang, S. Zheng, Y. Chen, M. Zhou, and X. Sun, “Simulation and Optimization of Pressure-Swing Distillation System for High Purity Acetonitrile,” vol. 58, no. Msota, pp. 96–100, 2016, doi: 10.2991/msota-16.2016.22.

Table 1. Columns’ Configuration

Parameter	COLUMN-1	COLUMN-2
Column Configuration		
Total Number of Stages	12	17
Rectification stages	6	7
Stripping Stages	4	8
Reflux Ratio	1.5	2
Column Pressure, kPa	101.3	101.3
Reboiler Duty, kCal/hr	3386	4000

Table 2. Feed Specifications for Initial Simulation Run

Parameter	COLUMN-1	MIXER, B1	COLUMN-2
Flowrate, Kg/hr	10	5	15
Mass Fraction			
Acetonitrile	0.5	0.995	~ 0.83
Water	0.5	0.005	~ 0.17
Temperature, °C	25	25	50
Pressure, kPa	101.3	101.3	101.3
Phase	Liquid	Liquid	Liquid
Feed Stage	6		8

Table 3. Variation of Azeotropic composition of Acetonitrile under Vacuum

Vacuum mm Hg	T K	Mass Fraction of Acetonitrile
	0	349.7
80	346.7	0.8303
160	343.3	0.8360
230	339.6	0.8437
310	335.5	0.8504
380	330.7	0.8600
460	325	0.8700
530	317.9	0.8842

610	308.5	0.9035
680	293.5	0.9338
710	285.1	0.9500
750	256.9	0.9900

Table 4. Results of Base Case Simulation

PARAMETER/STREAM	FEED- 1	DISTL- 1	RESID- 1	FEED- 2	FEED- M	DISTL- 2	RESID- 2
TEMPERATURE K	298.15	348.20	353.66	298.00	324.44	346.66	351.24
DENSITY KG/M³	784.31	697.93	841.94	782.14	746.88	699.86	718.70
AVERAGE MW	25.04	33.61	19.95	40.79	38.08	33.79	40.80
MASS FLOW KG/HR							
ACETONITRILE	5	4.1342	0.8658	4.975	9.1092	4.5365	4.5728
WATER	5	0.8658	4.1342	0.025	0.8908	0.8892	1.57E-03
MASS FRAC							
ACETONITRILE	0.5	0.8268	0.1732	0.995	0.9109	0.8361	0.9997
WATER	0.5	0.1732	0.8268	5.00E-03	0.0891	0.1639	3.43E-04
TOTAL FLOW KG/HR	10	5	5	5	10.0	5.4257	4.5743
TOTAL FLOW L/MIN	0.2125	0.1194	0.0990	0.1065	0.2276	0.1292	0.1060

Table 5. Simulation Result for the optimized Columns

FEED- 1	DISTL- 1	RESID- 1	FEED-2	FEED- M	DISTL- 2	RESID-2
------------	-------------	-------------	--------	------------	-------------	---------

	1	1	1		M	2	
Temperature K	298.15	348.20	351.16	298.00	310.34	346.83	351.15
Density gm/cc	784.31	697.91	813.32	782.14	757.16	703.56	719.25
Average MW	25.04	33.59	20.86	40.79	38.90	35.90	40.99
Mass Flow							
kg/hr							
Acetonitrile	5	3.6390	1.3610	14.925	18.5640	6.5277	12.0363
WATER	5	0.7657	4.2343	0.075	0.8407	0.8262	1.45E-02
Mass Frac							
Acetonitrile	0.5	0.8262	0.2432	0.995	0.9567	0.8876	0.999
WATER	0.5	0.1738	0.7568	5.00E-03	0.0433	0.1124	1.20E-03
Total Flow kg/hr	10	4.4048	5.5953	15	19.4048	7.3540	12.0508
Total Flow l/min	0.2125	0.1052	0.1147	0.3196	0.4271	0.1742	0.2792

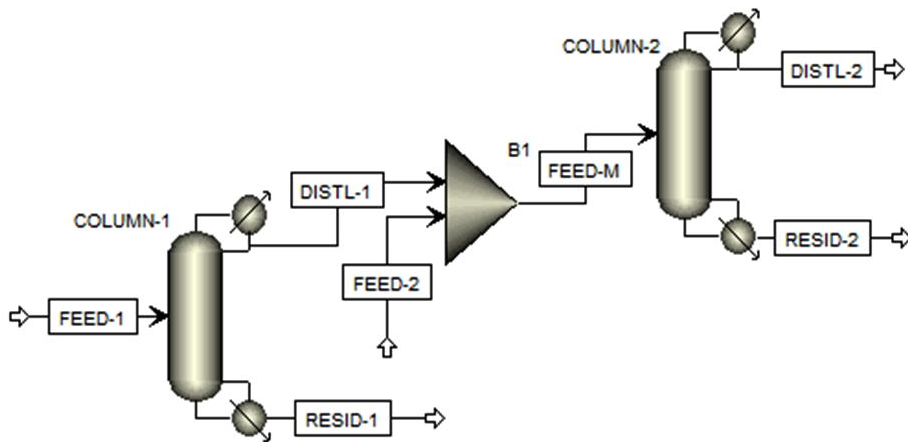

Figure 1. The Aspen Plus Flow sheet for the simulation of Distillation Operation for Acetonitrile-water system.

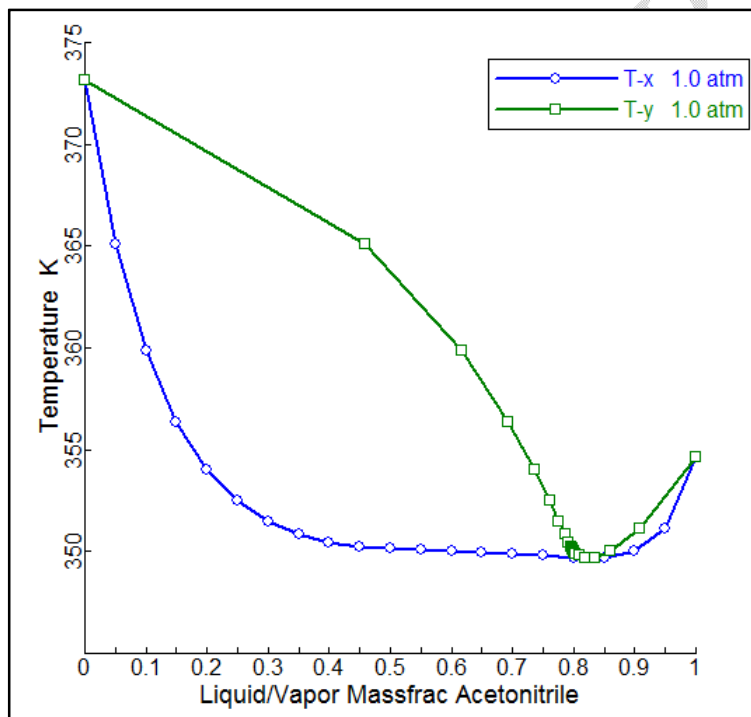

Figure 2. T-xy Diagram for the Acetonitrile-water Binary System

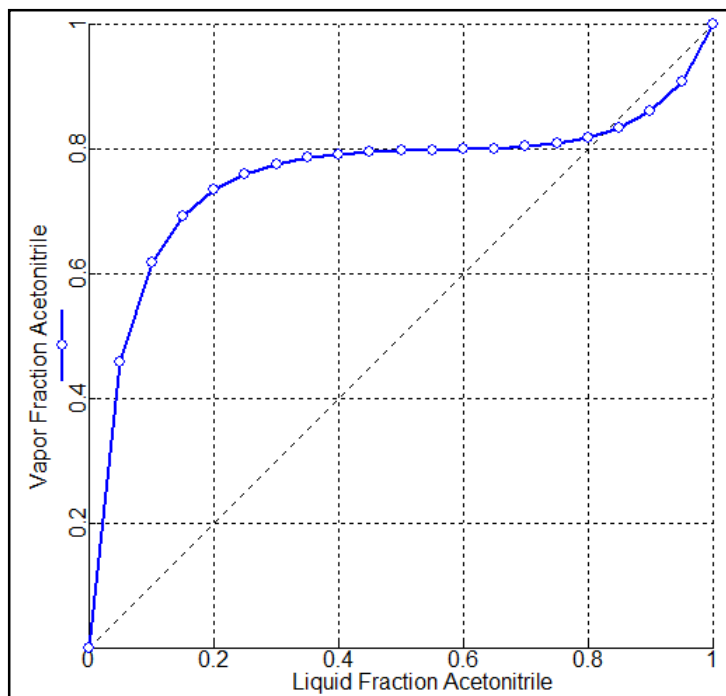

Figure 3. y-x Diagram for the Acetonitrile-water Binary System

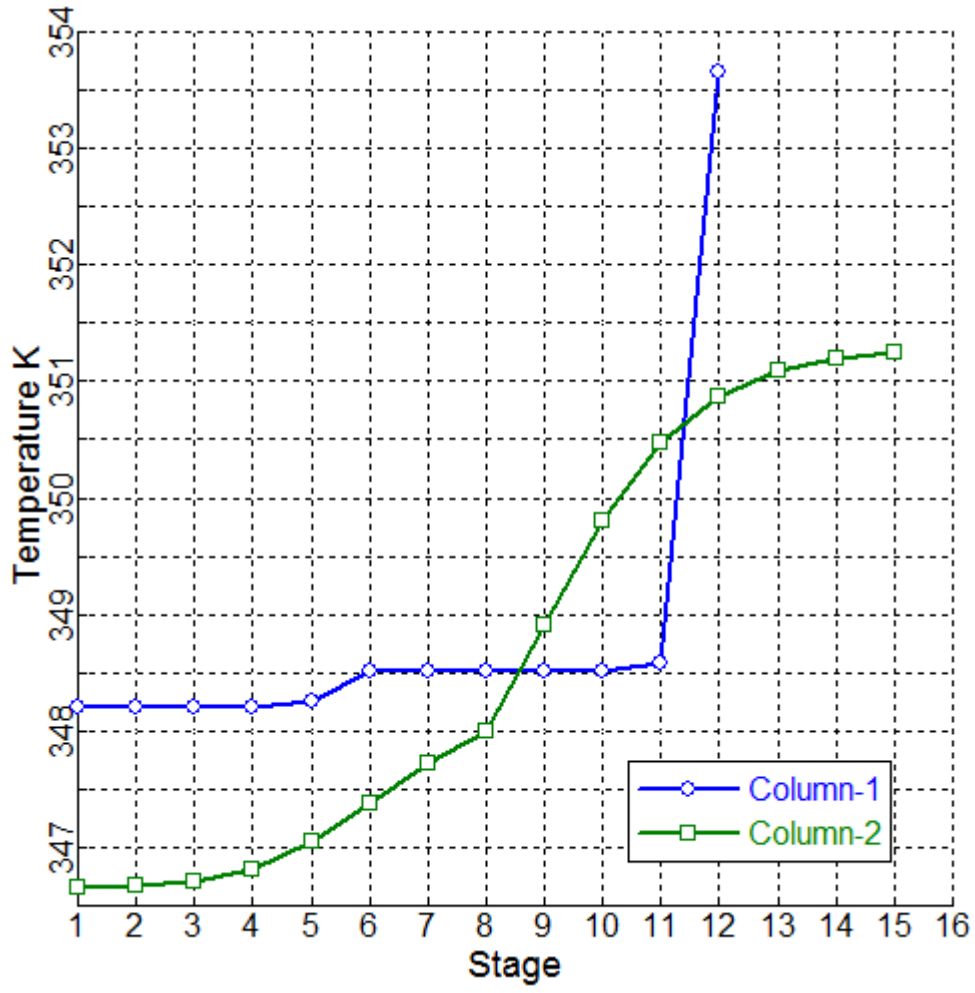

Figure 4. Temperature Profile

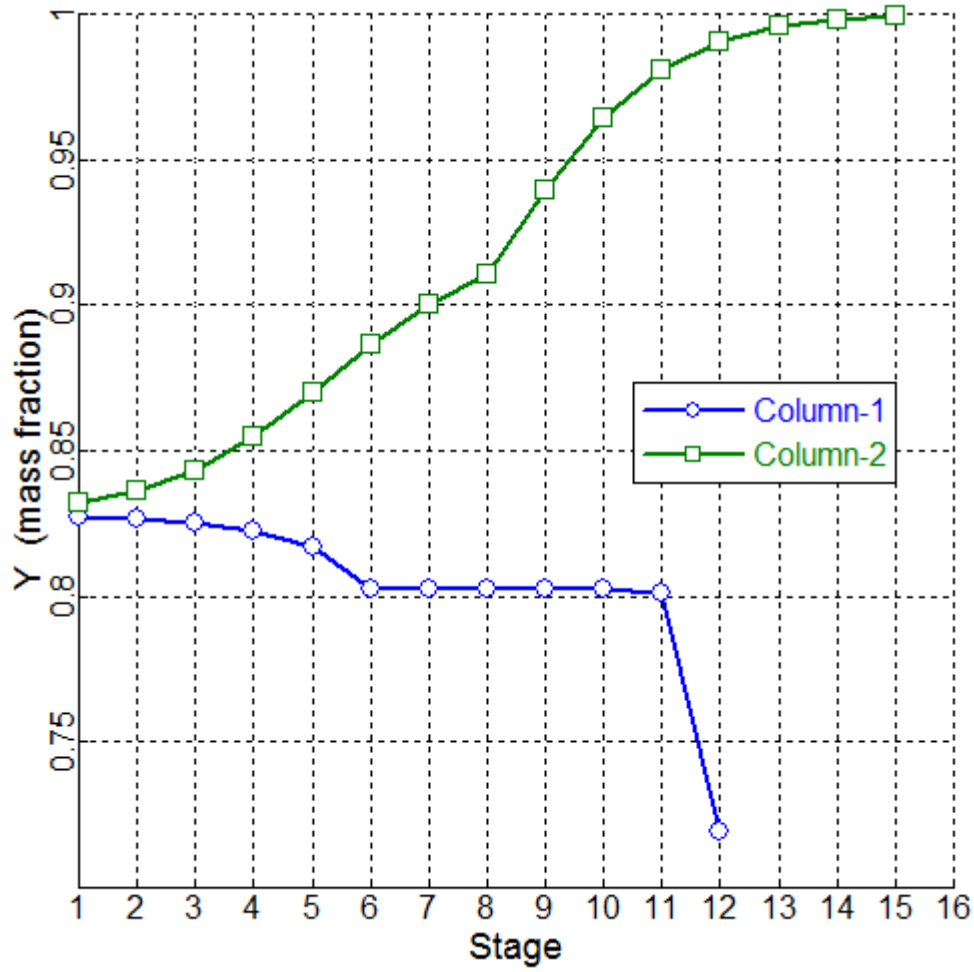

Figure 5. Vapor Composition Profile

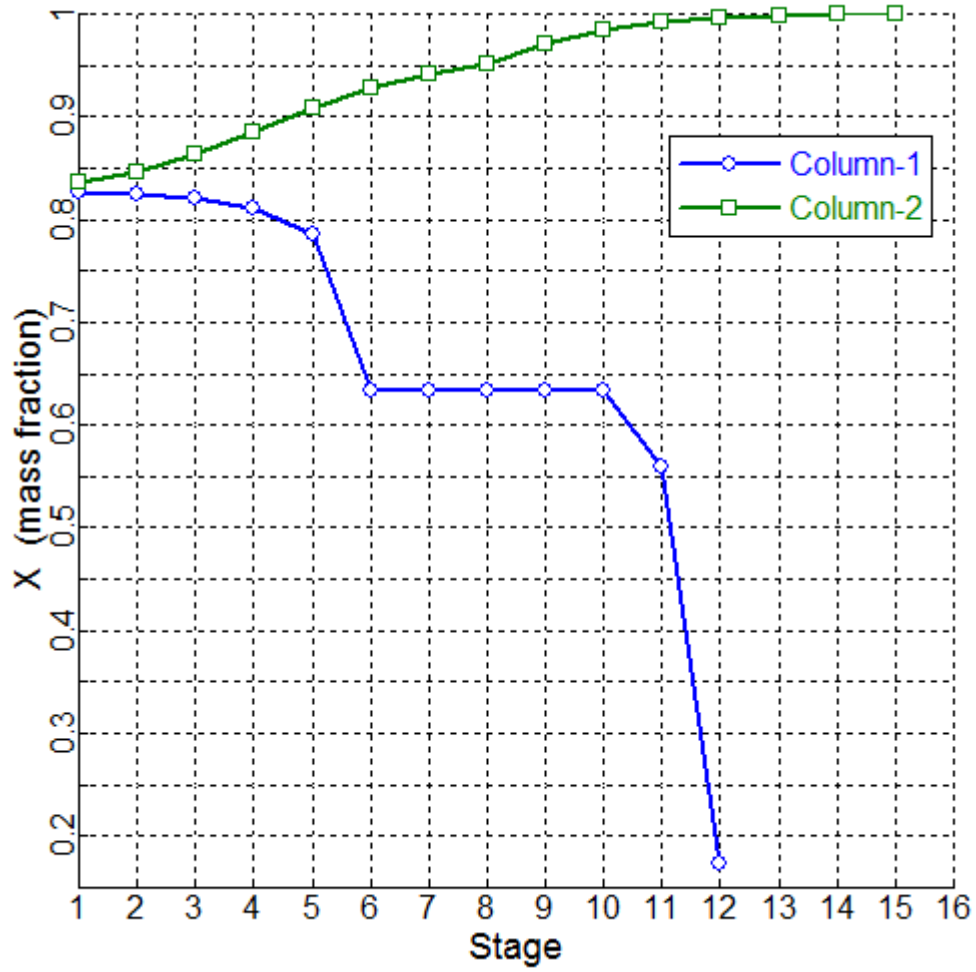

Figure 6. Liquid Composition Profile for Acetonitrile

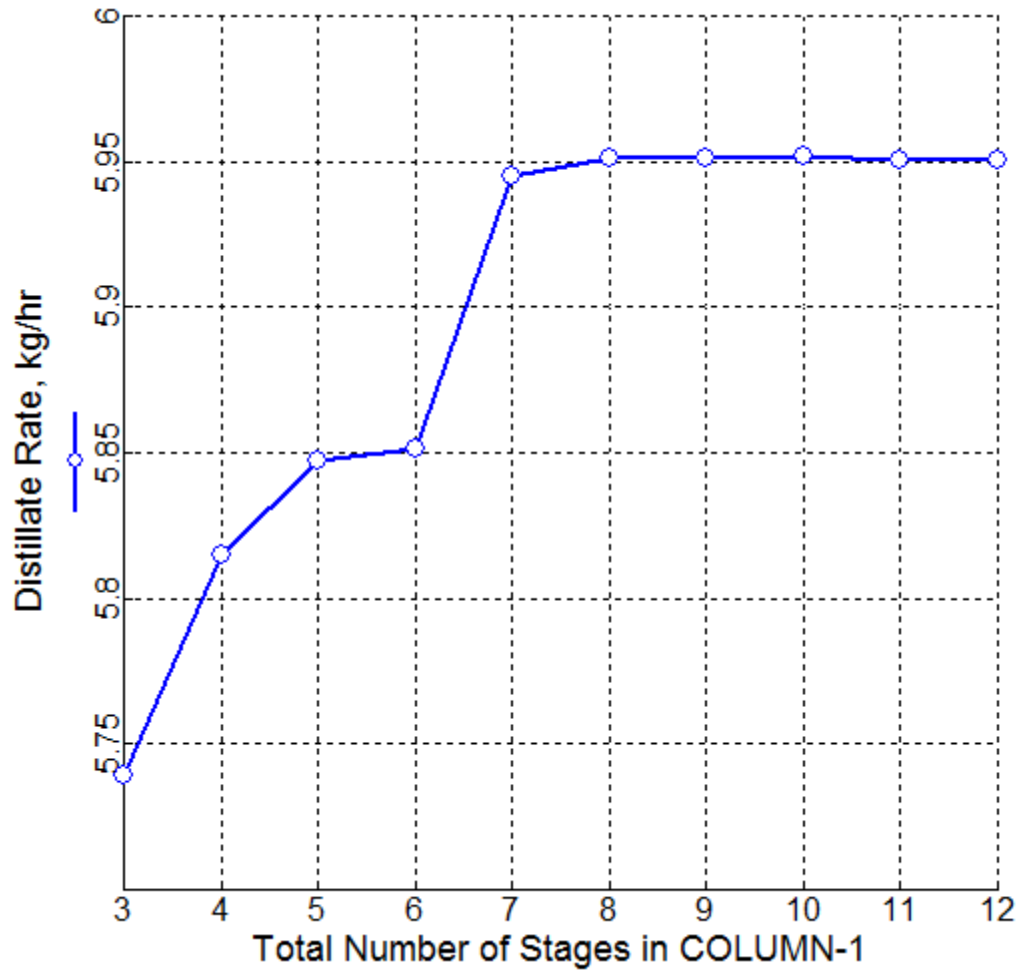

Figure 7. Variation of Distillate Rate with Number of Stages in Column-1

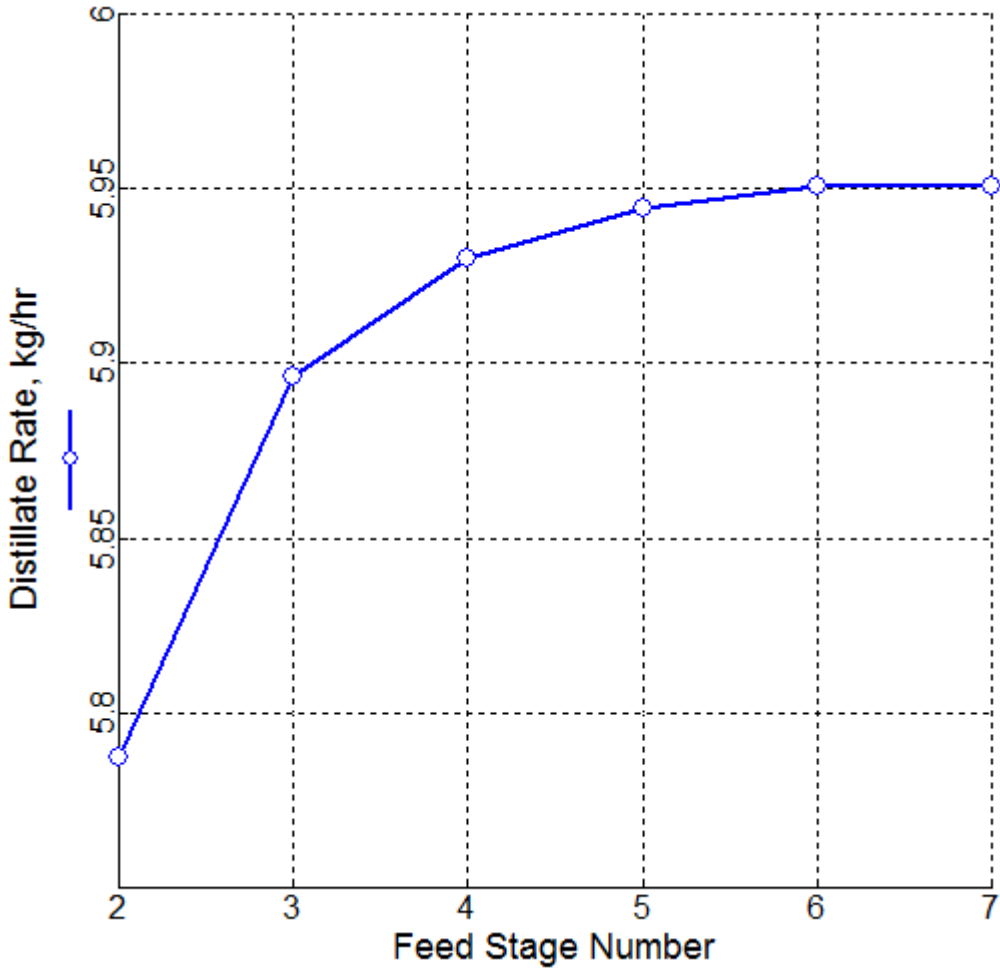
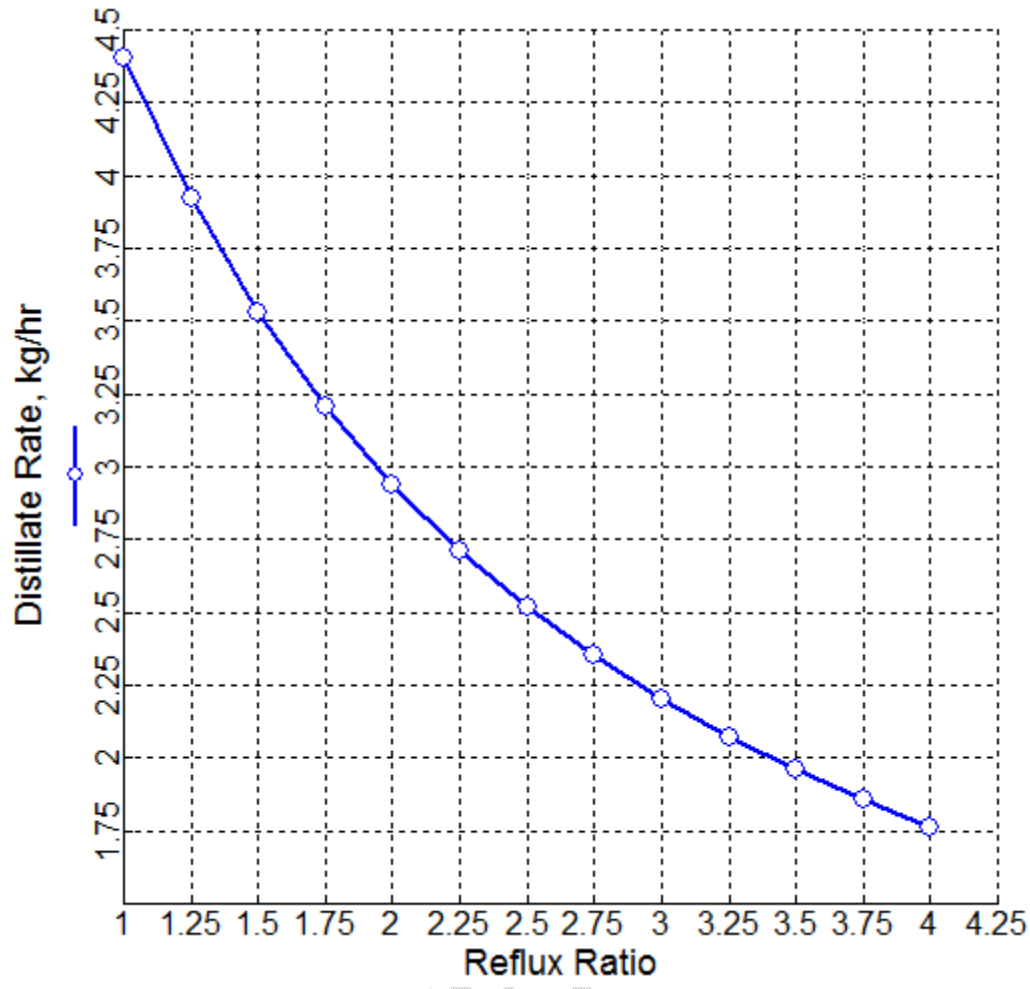

Figure 8. Variation of Distillate Rate with Feed Stage Location in Column-1



a

Figure 9. Variation of Distillate Rate with Reflux Ratio in Column-1

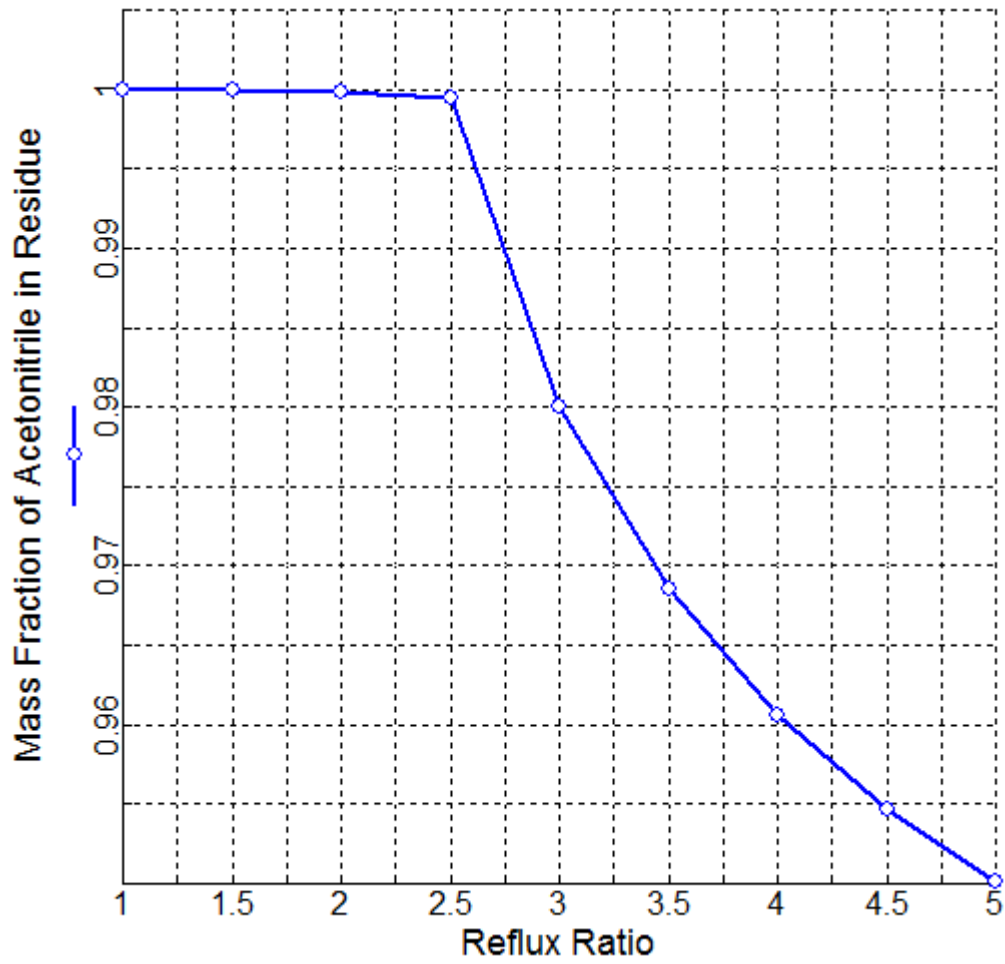

Figure 10. Variation of Mass Fraction of Acetonitrile with Reflux Ratio in Column-2

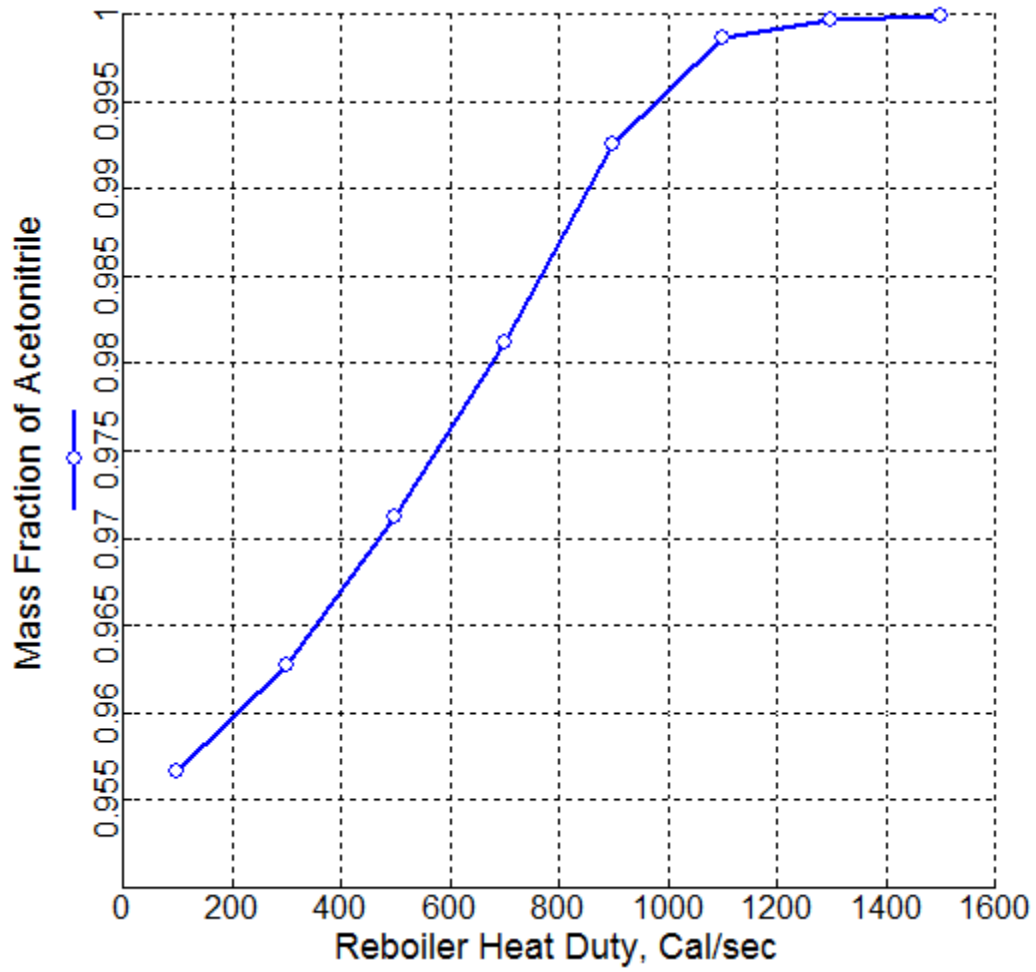

Figure 11. Variation of Mass Fraction of Acetonitrile with Reboiler Duty for Column-2

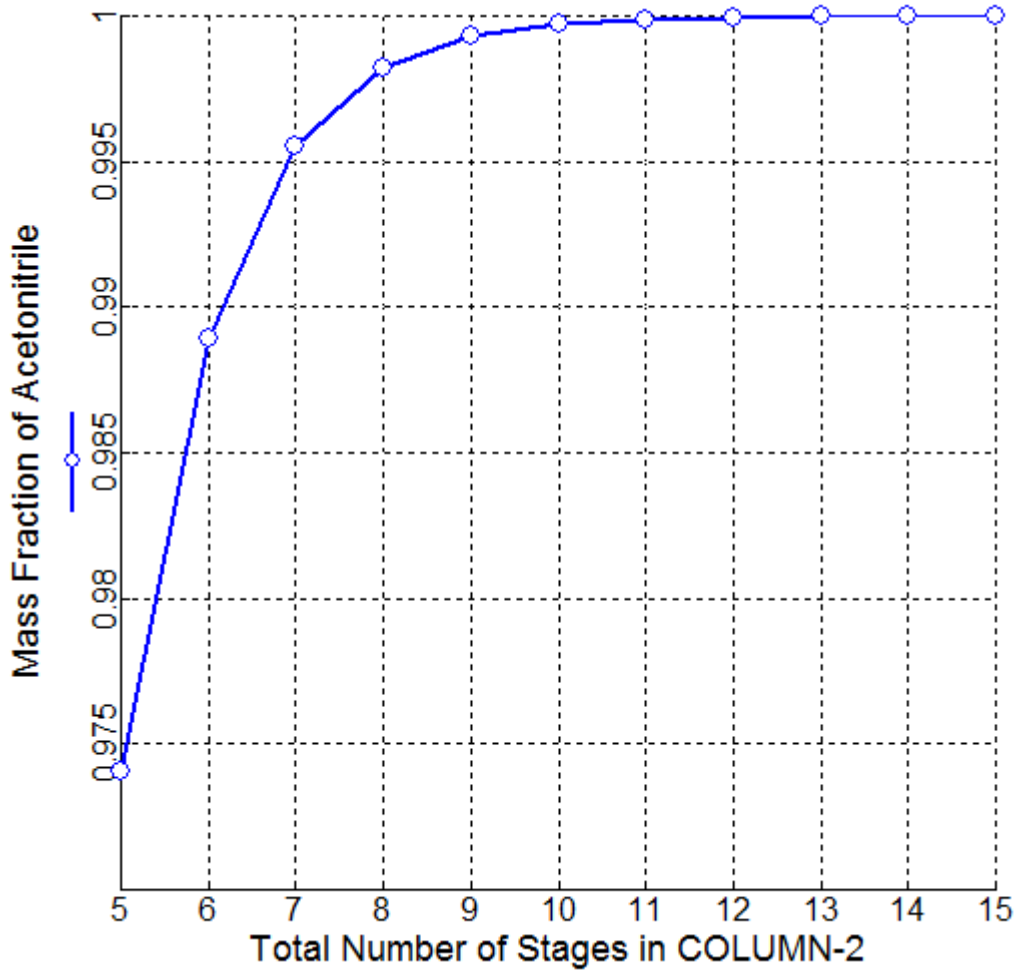

Figure 12. Variation of Mass Fraction of Acetonitrile with Total Number of Stage in Column-2

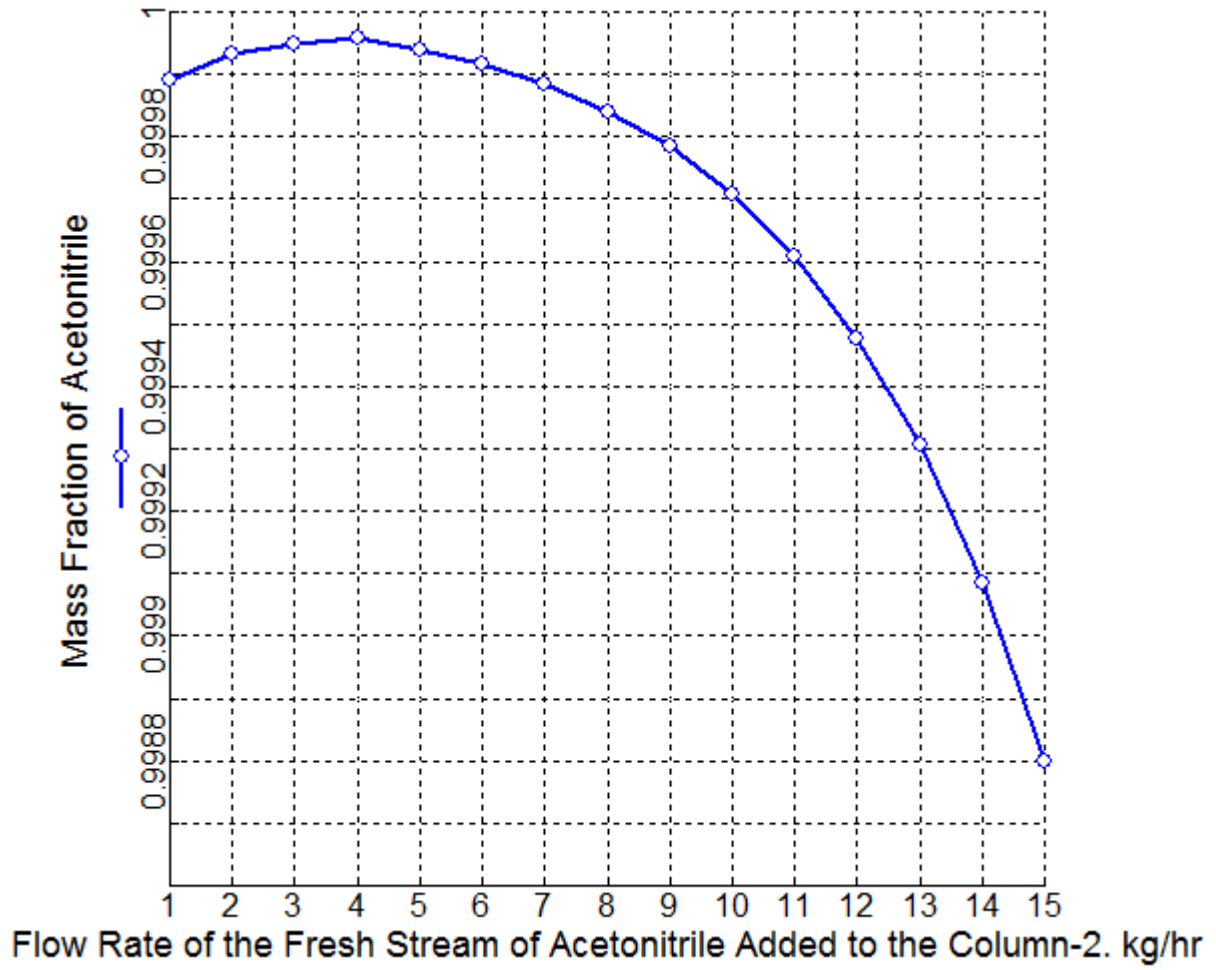

Figure 13. Variation of Mass Fraction of Acetonitrile with Flow Rate of the Fresh Stream of Acetonitrile Added to the Column-2.

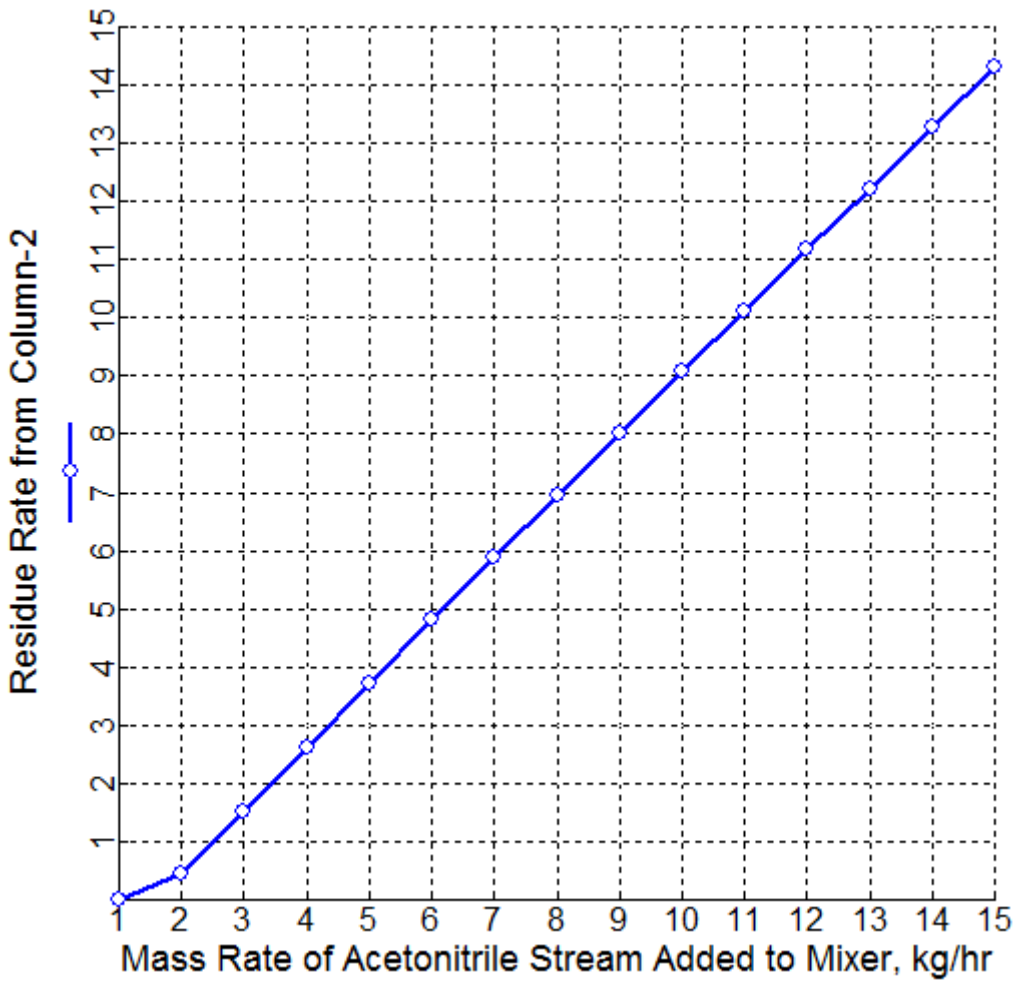

Figure 14. Variation of Residue Mass Rate with Flow Rate of the Fresh Stream of Acetonitrile Added to the Column-2