

MODELLING DYNAMICS OF HPV AND CERVICAL CANCER INCORPORATING PROTECTION

Abstract

Human papilloma Virus (HPV) is the primary infection that causes Cervical cancer. Due to the high cost of treatment for cervical cancer, protection against HPV and Cervical cancer infection may be preferable in a scarce resource settings. From the studies done, analysis of the data collected shows that vaccination has the potential to help prevent HPV and cervical cancer infection and slow down the epidemic. In this paper, a deterministic model that incorporates protection against the infection was developed and analysed to assess the impact of protection on the dynamics of HPV and cervical cancer infection. The qualitative analysis of the model showed that the infection dynamics can best be described by the threshold value R_0 which was computed using the next generation matrix approach. Stability analysis of the model showed that Disease Free Equilibrium (DFE) is locally and globally asymptotically stable whenever $R_0 < 1$. The Endemic Equilibrium (EE) exists and is locally and globally asymptotically stable when $R_0 > 1$. The effectiveness of protection is achieved if well done hence, an increase in protection leads to low disease prevalence in a population.

Keywords: Protection, Human papilloma Virus, Cervical cancer, Reproduction Number, Stability Analysis.

1 Introduction

Human papillomavirus (HPV) is a common sexually transmitted infection and has been shown in epidemiological and molecular studies to be the main course of cervical cancer. Over one hundred dissimilar strains of HPV being identified and classified with HPV types 16, 18, 31 and 45 been classified as “high-risk”. Human papillomavirus type 16 is the most common high-risk type, accounting for more than half (56 percent) of all cervical cancers. Persistent infection with

high-risk types is the most important risk factor for cervical cancer. There is no treatment for HPV but in most cases it disappears naturally. However, with persistent infections the high risk strains may become chronic and shed HPV virions [6].

Although the majority of HPV infections do not cause symptoms and resolve spontaneously, persistent infection with HPV may result in disease. In women, persistent infection with specific HPV types most frequently HPV-16 and HPV-18 may lead to precancerous lesions which, if untreated, may progress to cervical cancer. So far, it has not yet been discovered which individual who have Human papilloma Virus can progress to cancer or any other health complications but studies show that persons with puny immune systems as well as those with HIV/AIDS and severe diseases might not be capable to combat off the virus. Sexually active females are at a higher risk of infection with human papilloma virus, the virus which causes cervical cancer, however no much information is there about the occurrence of the HPV infection. After development of symptoms or any other health problems is when some people will realise they have human papilloma virus but others will neither know they are infected nor develop symptoms from it. Changes in the cervical cells develop into cervical cancer in what is referred to as the precancerous conditions of the cervix. Early stages of cervical cancer do not yield symptoms or signs. However, as the surrounding tissues are invaded by the cancer cells, the symptoms may appear [6, 19].

When signs show, one of the most prevalent symptoms is uncharacteristic bleeding of the birth canal. This may comprise unusual bleeding in between menstrual times, bleeding after sexual contact or a pelvic examination, or blood loss after douching. Uncommon or mysterious variations in the menstrual sequence, such as unusually substantial menstrual blood loss and bleeding after menopause, are correspondingly possible indications of cancer of the cervix. Other symptoms and signs that may accompany the condition include vaginal discharge, pelvic pain and pain during sexual intercourse. When cervical cancer has spread throughout the body (metastasized), it may cause general symptoms and signs like fatigue and weight loss. Several treatment options are available, the type of treatment administered is dependent on the stage where the specific cancer manifests itself. These treatment options include but not limited to chemotherapy, surgery and radiography. Palliative care is a key plank in management and containment of cancer, especially in the assuaging of severe pains and mollifying the suffering of cancer patients. When detected early and attended to effectively, cervical cancer is a form of cancer that can be successfully managed. However, appropriate treatment and palliative care can handle late stage diagnosed cancers. Public health problem like cervical

cancer can be eliminated if comprehensive approach to prevention, screening and treatment is done [1, 9, 12].

Three prophylactic HPV vaccines, directed against high risk HPV types, are currently available and marketed in many countries worldwide for the prevention of HPV related disease: the quadrivalent vaccine was first licensed in 2006, the bivalent vaccine in 2007 and the nonavalent vaccine in 2014. All of these vaccines are intended to be administered if possible before the onset of sexual activity, that is, before first exposure to HPV infection. None of the vaccines contains live biological products or viral DNA, and are therefore non-infectious; they do not contain antibiotics or preservative agents [10, 16]

Despite the many intervention strategies put in place, the impact of HPV and cervical cancer is pervasive and far-reaching, affecting individuals and communities not only psychologically but also economically and socially. Families lose their most productive members due to this disease, leaving children and elderly people without means of support. Although screening and treatment strategies appear promising, protection remains the most effective strategy against the spread of HPV and cervical cancer infections. Screening has been studied numerously [14, 18]. Vaccination has also been presented [1, 11, 13, 14, 15, 18], but Screening and vaccination alone is unlikely to lead to elimination of HPV and cervical cancer thus, effective programs to reduce HPV transmission are still needed.

As no specific treatment is available against HPV and due to the treatment cost for cervical cancer, more emphasis is needed on the protection rather than treating the infections. In this context, protection includes Vaccination, screening, practising abstinence, having limited number of sexual partners at any age, using condoms for every sexual encounter, not starting having sex and young age and adopting a healthy lifestyle to strengthen the immune system. Thus, this study develops a deterministic model to investigate the the impact of protection on the transmission dynamics and management of HPV and cervical cancer.

2 The model

The model considered a sexually active population of girls and boys aging 15 years and above who mixes homogeneously such that all individuals are equally likely to be infected with HPV infection. The total human population at any time t denoted by N is subdivided into classes, $S(t)$ the class of individuals susceptible to HPV and cervical cancer infections. Recruitment into susceptible class is done at a rate Λ . The class $P(t)$ consist of individuals protected

against HPV infection, this protection is done at a rate η . ρ is the protection inefficacy where $0 \leq \rho \leq 1$. So $(1 - \rho)$ represents the protection efficacy. If $\rho = 1$, then it offers 100 percent protection against the disease. The class $I_h(t)$ consists of individuals who are asymptotically infected with HPV infection, this infection occurs at the rate λ . Most HPV infected Individuals recover from the infection at a rate α and slide back to the $S(t)$ class, γ is the rate of progression to the cervical cancer $C(t)$ class due to persistence of the HPV infection. A small fraction of the infected individuals will proceed to cervical cancer since most of the HPV clears on its own and only females suffer from cervical cancer. Mortality occurs among cervical cancer patients at the rate ν while natural death is assumed to occur in all classes at the rate μ .

The rate at which the susceptible individuals acquire HPV infection is defined as

$$\lambda = \frac{\kappa\beta I_h(t)}{N(t)} \tag{1}$$

Where κ is the effective contact rate with HPV infected individuals while β the average number of sexual partners. With the assumption that, high viral load increases the probability of persistence of the HPV infection and thus exposes the individuals to cervical cancer.

From the above definitions, the resulting diagram for the model is given below.

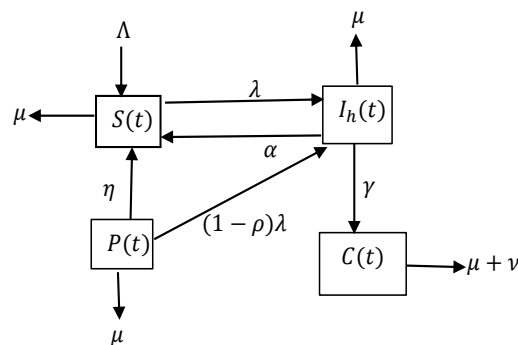

Figure 1: Model flow diagram

The dynamics described can be represented mathematically as:

$$\begin{aligned}
 \dot{S}(t) &= \Lambda + \alpha I_h(t) - \frac{\kappa\beta I_h(t)}{N(t)} S(t) - (\eta + \mu)S(t) \\
 \dot{P}(t) &= \eta S(t) - \frac{(1 - \rho)\kappa\beta I_h(t)}{N(t)} P(t) - \mu P(t) \\
 \dot{I}_h(t) &= \frac{\kappa\beta I_h(t)}{N(t)} S(t) + \frac{(1 - \rho)\kappa\beta I_h(t)}{N(t)} P(t) - (\gamma + \alpha + \mu)I_h(t) \\
 \dot{C}(t) &= \gamma I_h(t) - (\nu + \mu)C(t)
 \end{aligned} \tag{2}$$

Since the model in Equation (2) describes a human population, the model developed is positive and bounded for all $t \geq 0$ with;

$$N(t) = P(t) + S(t) + I_h(t) + C(t) \tag{3}$$

Thus all the state variables in Equation (2) will remain positive so that the solutions of the model with positive initial conditions will remain positive for all $t > 0$. Using the next generation matrix approach [8], the basic reproduction number of model (2) in the presence of protection is defined as

$$R_0 = \frac{\kappa\beta S(t)}{N(t)(\mu + \alpha + \gamma)} + \frac{\rho\kappa\beta P(t)}{N(t)(\mu + \alpha + \gamma)} \tag{4}$$

At the boundary $N \rightarrow \frac{\Lambda}{\mu}$ as $t \rightarrow \infty$ and at DFE

$$S(t) = \frac{\Lambda}{\mu + \eta} \text{ and } P(t) = \frac{\eta\Lambda}{\mu(\mu + \eta)}$$

Thus equation (4) becomes

$$R_0 = \frac{\kappa\beta}{(\mu + \alpha + \gamma)} \left\{ \frac{\mu + \eta(1 - \rho)}{\mu(\mu + \eta)} \right\} \tag{5}$$

This shows that, when the vaccination is 100 percent efficiency, $\eta = 1$, R_{0v} becomes

$$R_0 = \frac{\kappa\beta}{(\mu + \alpha + \gamma)} \left\{ \frac{\mu}{\mu(\mu + \eta)} \right\}$$

3 Local Stability Analysis of the Disease Free Equilibrium

The model developed in Equation (2) has a disease free equilibrium (DFE) given by $E_0 = \{S(t), P(t), I_h(t), C(t)\} = \left\{ \frac{\Lambda}{\mu + \eta}, \frac{\eta\Lambda}{\mu(\mu + \eta)}, 0, 0 \right\}$

Theorem 3.1. *If $R_0 < 1$ then $E_0 = \{S(t), P(t), I_h(t), C(t)\} = \left\{ \frac{\Lambda}{\mu + \eta}, \frac{\eta\Lambda}{\mu(\mu + \eta)}, 0, 0 \right\}$ is the equilibrium in Ω and is locally asymptotically stable.*

Proof. Consider the Jacobian matrix of Equation (2) given by

$$J = \begin{pmatrix} -(\mu + \eta) & 0 & \alpha - \kappa\beta & 0 \\ \eta & -\mu & -(1 - \rho)\kappa\beta & 0 \\ 0 & 0 & \frac{\kappa\beta S(t)}{N(t)} + \frac{(1-\rho)\kappa\beta P(t)}{N(t)} - (\gamma + \alpha + \mu) & 0 \\ 0 & 0 & \gamma & -(\mu + \nu) \end{pmatrix} \quad (6)$$

To investigate the stability of the DFE, we compute the eigenvalues of Equation (6)

$$J = \begin{pmatrix} -(\mu + \eta) - \lambda & 0 & \alpha - \kappa\beta & 0 \\ \eta & -\mu - \lambda & -(1 - \rho)\kappa\beta & 0 \\ 0 & 0 & (\gamma + \alpha + \mu)\{R_0 - 1\} - \lambda & 0 \\ 0 & 0 & \gamma & -(\mu + \nu) - \lambda \end{pmatrix} \quad (7)$$

By Routh-Hurwitz criterion [17], the eigenvalues obtained by equation (7) are negative since the trace

$$Tr = \nu + 4\mu + \eta + (\gamma + \alpha + \mu)\{R_0 - 1\} < 0$$

And the determinant

$$det = (\gamma + \alpha + \mu)(R_0 - 1)(\eta\mu + \mu^2)(-\mu - \nu) > 0 \text{ when } R_0 < 1.$$

Hence, the Disease free equilibrium E_0 is locally asymptotically stable whenever $R_0 < 1$. Given a small initial infective population each infected individual in the entire period of infectivity will produce less than one infected individual on average if $R_0 < 1$, hence the disease will not invade the population. \square

4 Global stability of Disease-free Equilibrium point

For global stability of the DFE, the technique by Castillo [4] is used.

$$\begin{aligned} \frac{dX}{dt} &= H(X, Z), \\ \frac{dZ}{dt} &= G(X, Z), G(X, 0) = 0 \end{aligned} \quad (8)$$

where $X \in \mathbb{R}^2$ and $X = \{S(t), P(t)\}$, denotes the number of uninfected individuals and $Z \in \mathbb{R}^2$ where $Z = \{I_h(t), A(h)\}$ denotes the number of infected individuals. $E_0 = (X, 0)$ denotes the disease free equilibrium point of this

system where

The two conditions that if met guarantee global asymptotic stability of the DFE include

$$\frac{dX}{dt} = H(X, 0), X^* \text{ is globally asymptotically stable (GAS)}$$

$$G(X, Z) = PZ - \hat{G}(X, Z), \hat{G}(X, Z) \geq 0 \text{ for } (X, Z) \in \Omega \quad (9)$$

Where $P = D_z G(X^*, 0)$ is an M-matrix (the off-diagonal elements of P are non-negative) and Ω is the region where the model makes biological sense.

Theorem 4.1. *The fixed points $E_0 = (X^*, 0)$ is Globally asymptotically stable provided $R_0 < 1$.*

Proof. Consider

$$H(X, O) = \Lambda - \mu S, \eta S(t) - \mu P(t) \text{ and } G(X, Z) = PZ - \hat{G}(X, Z)$$

$$\text{Where } P = \begin{pmatrix} -(\alpha + \gamma + \mu) & 0 \\ \gamma & -(\mu + \nu) \end{pmatrix}$$

And

$$G(X, Z) = \begin{pmatrix} \hat{G}_1(X, Z) \\ \hat{G}_2(X, Z) \end{pmatrix} = \begin{pmatrix} -(\kappa\beta(1 - S(t) + \rho P(t))I_h(t)) \\ 0 \end{pmatrix}$$

It follows that $\hat{G}_1(X, Z) \geq 0$ and $\hat{G}_2(X, Z) = 0$ thus $\hat{G}(X, Z) \geq 0$ and so the conditions in (9) are met so E_0 is globally asymptotically stable when $R_0 < 1$.

Global asymptotic stability shows that regardless of any starting solution, the solutions of the model will converge to DFE whenever $R_0 < 1$.

□

5 Local stability of endemic equilibrium point

The endemic equilibrium state is the state where the disease cannot be totally eradicated but remains in the population at manageable levels. HPV and Cervical cancer are endemic or persistent in the population if $S^*(t), P^*(t), I_h^*(t), C(t) > 0$ for all $t > 0$.

Theorem 5.1. *The endemic equilibrium point EE, denoted E^* is locally asymptotically stable whenever $R_0 > 1$ otherwise unstable.*

Proof. Consider the Jacobian matrix of of model (2) at Endemic equilibria where $E^* = S^*(t), P^*(t), I_h^*(t), C(t) > 0$

$$J = \begin{pmatrix} -(\mu + \eta) - \frac{\kappa\beta I_h^*}{N} & 0 & \alpha - \frac{\kappa\beta S^*}{N} & 0 \\ \eta & -\mu - \frac{(1-\rho)\kappa\beta I_h^*}{N} & \frac{(1-\rho)\kappa\beta P^*}{N} & 0 \\ \frac{\kappa\beta I_h^*}{N} & \frac{(1-\rho)\kappa\beta I_h^*}{N} & a & 0 \\ 0 & 0 & \gamma & -(\mu + \nu) \end{pmatrix} \quad (10)$$

Where $a = \frac{\kappa\beta S^*}{N(t)} + \frac{(1-\rho)\kappa\beta P^*}{N(t)} - (\gamma + \alpha + \mu)$. Clearly $-(\mu + \nu)$ is an eigenvalue which is negative and the remaining eigenvalues can be determined from.

$$J = \begin{pmatrix} -(\mu + \eta) - \frac{\kappa\beta I_h^*}{N} & 0 & \alpha - \frac{\kappa\beta S^*}{N} \\ \eta & -\mu - \frac{(1-\rho)\kappa\beta I_h^*}{N} & \frac{(1-\rho)\kappa\beta P^*}{N} \\ \frac{\kappa\beta I_h^*}{N} & \frac{(1-\rho)\kappa\beta I_h^*}{N} & \frac{\kappa\beta S^*}{N(t)} + \frac{(1-\rho)\kappa\beta V^*}{N(t)} - (\gamma + \alpha + \mu) \end{pmatrix} \quad (11)$$

Using Routh-Hurwitz criterion [17], the eigenvalues obtained by matrix (11) are negative since the trace $tr = -2\mu - \eta - \frac{(1-\rho)\kappa\beta I_h^*}{N} + (R_0 - 1)(\gamma + \alpha + \mu) < 0$ and the determinant

$$\det = \frac{-\kappa\beta I_h^*(\alpha - \frac{\kappa\beta S^*}{N})}{N} + (R_0 - 1)(-\eta - \frac{\kappa\beta I_h^*}{N} - \mu)(\gamma + \alpha + \mu)(-\mu - \frac{(1-\rho)\kappa\beta I_h^*}{N}) - \kappa\beta I_h^*(-\eta(\alpha - \frac{\kappa\beta S^*}{N}) - \frac{\kappa\beta P^*(-\eta - \frac{\kappa\beta I_h^*}{N} - \mu(1-\rho))}{N})(1 - \rho) > 0.$$

When $R_0 > 1$. This implies that the Routh-Hurwitz criterion holds and thus the endemic Equilibrium (E^*) of model (2) is locally asymptotically stable. \square

Epidemiologically, If $R_0 > 1$, then each HPV infected individual in the entire period of infectivity will produce more than one infected individuals on average, which shows the disease will persist in the population.

6 Global stability of endemic equilibrium point

The global stability of the equilibrium is obtained by means of Lyapunov's direct method and LaSalle's invariance principle De Leon [7].

Theorem 6.1. *The endemic equilibrium E^* of model (2) is globally asymptotically stable in Ω whenever $R_0 > 1$.*

Proof. Consider the non-linear Lyapunov function

$$W : (S(t), I_h(t), C(t)) \in \Omega \subset \mathbb{R}_+^3 : S(t), P(t), I_h(t), C(t) > 0$$

defined as

$$W = S - S^* \ln S + P - P^* \ln P + I_h - I_h^* \ln I_h + C - C^* \ln C \quad (12)$$

where W is in the interior of the region Ω . E^* is the global minimum of W on Ω and $W : \{S(t), P(t), I_h(t), C(t)\} = 0$. Differentiating W with respect to time gives

$$\frac{dW}{dt} = \dot{W} = \dot{S}\left(1 - \frac{S^*}{S}\right) + \dot{P}\left(1 - \frac{P^*}{P}\right) + \dot{I}_h\left(1 - \frac{I_h^*}{I_h}\right) + \dot{C}\left(1 - \frac{C^*}{C}\right) \quad (13)$$

Replacing $\dot{S}, \dot{P}, \dot{I}_h, \dot{C}$ from equation (2) in equation (12) we obtain

$$\begin{aligned} \dot{W} = & [\Lambda + \alpha I_h(t) - \frac{\kappa\beta I_h(t)}{N(t)} S(t) - (\eta + \mu) S(t)] \left(1 - \frac{S^*}{S}\right) + [\eta S(t) - \frac{(1-\rho)\kappa\beta I_h(t)}{N(t)} P(t) - \\ & \mu P(t)] \left(1 - \frac{P^*}{P}\right) + \left[\frac{\kappa\beta I_h(t)}{N(t)} S(t) + \frac{(1-\rho)\kappa\beta I_h(t)}{N(t)} P(t) - (\gamma + \alpha + \mu) I_h(t)\right] \left(1 - \frac{I_h^*}{I_h}\right) + \\ & [\gamma I_h(t) - (\nu + \mu) C(t)] \left(1 - \frac{C^*}{C}\right) \end{aligned}$$

At boundary $N \leq \frac{\Lambda}{\mu}$, we let $N = \frac{\Lambda}{\mu}$

$$\begin{aligned} \dot{W} = & [\Lambda + \alpha I_h(t) - \frac{\mu\kappa\beta I_h(t) S(t)}{\Lambda} - (\eta + \mu) S(t)] \left(1 - \frac{S^*}{S}\right) + [\eta S(t) - \frac{(1-\rho)\mu\kappa\beta I_h(t) P(t)}{\Lambda} - \\ & \mu P(t)] \left(1 - \frac{P^*}{P}\right) + \left[\frac{\mu\kappa\beta I_h(t) S(t)}{\Lambda} + \frac{(1-\rho)\mu\kappa\beta I_h(t) P(t)}{\Lambda} - (\gamma + \alpha + \mu) I_h(t)\right] \left(1 - \frac{I_h^*}{I_h}\right) + \\ & [\gamma I_h(t) - (\nu + \mu) C(t)] \left(1 - \frac{C^*}{C}\right) \end{aligned}$$

At steady state the following results from model (2)

$$\begin{aligned} \Lambda + \alpha I_h(t) &= \frac{\mu\kappa\beta I_h(t) S(t)}{\Lambda} - (\eta + \mu) S(t) \\ \eta S(t) &= \frac{(1-\rho)\mu\kappa\beta I_h(t) P(t)}{\Lambda} - \mu P(t) \\ \frac{\mu\kappa\beta I_h(t) S(t)}{\Lambda} + \frac{(1-\rho)\mu\kappa\beta I_h(t) P(t)}{\Lambda} &= (\gamma + \alpha + \mu) I_h(t) \\ \gamma I_h(t) &= (\nu + \mu) C(t) \end{aligned} \quad (14)$$

Thus

$$\begin{aligned} \dot{W} = & \left[\frac{\mu\kappa\beta I_h(t) S(t)}{\Lambda} - (\eta + \mu) S(t) - \frac{\mu\kappa\beta I_h(t) S(t)}{\Lambda} - (\eta + \mu) S(t)\right] \left(1 - \frac{S^*}{S}\right) + [\eta S(t) - \\ & \frac{(1-\rho)\mu\kappa\beta I_h(t) P(t)}{\Lambda} - \mu P(t)] \left(1 - \frac{P^*}{P}\right) + \left[\frac{\mu\kappa\beta I_h(t) S(t)}{\Lambda} + \frac{(1-\rho)\mu\kappa\beta I_h(t) P(t)}{\Lambda} - (\gamma + \alpha + \mu) I_h(t)\right] \left(1 - \frac{I_h^*}{I_h}\right) + \\ & [\gamma I_h(t) - (\nu + \mu) C(t)] \left(1 - \frac{C^*}{C}\right) \\ = & \left\{ \frac{\mu\kappa\beta I_h^*(t) S^*(t)}{\Lambda} + \eta S^* + \mu S^* \right\} \left(2 - \frac{S}{S^*} - \frac{S^*}{S}\right) + \eta S^* \left(1 - \frac{P^* S^*}{P S}\right) + \frac{\mu\kappa\beta I_h(t) S^*(t)}{\Lambda} \left(1 - \frac{S}{S^*}\right) + \\ & \frac{(1-\rho)\mu\kappa\beta I_h(t) P^*(t)}{\Lambda} \left(1 - \frac{P}{P^*} \frac{I_h^*}{I_h}\right) + \gamma I_h^* \left(1 - \frac{I_h C^*}{I_h^* C}\right) \end{aligned}$$

At $S = S^*$, $P = P^*$, $I_h = I_h^*$, $C = C^*$ and from the property that the geometric mean is less than or equal to the arithmetic mean, the inequality $\dot{W} \leq 0$ holds iff $(S(t), P(t), I_h(t), C(t))$ takes the equilibrium values

$S^*(t), P^*(t), I_h^*(t), C^*(t)$. Thus, by LaSalle's invariance principle De Leon [7], the endemic equilibrium E^* is globally asymptotically stable. Epidemiologically, any perturbation of the model by the introduction of infectives shows that the model solutions will converge to the E^* whenever $R_o > 1$. This implies that the disease transmission levels can be kept quite low or manageable with minimal deaths at the peak times of the re-occurrence

□

7 Sensitivity Analysis

Sensitivity analysis of R_0 with respect to the model parameters is carried out in order to determine the impact of protection in the control and management of HPV and cervical cancer infection [5]. To perform sensitivity analysis of the reproduction number R_0 in Equation (5), the normalised forward sensitivity index also known as elasticity [2] was used as follows:

$$\begin{aligned}
 \Gamma_{\beta}^{R_0} &= \frac{\partial R_0}{\partial \beta} \times \frac{\beta}{R_0} = 1 \\
 \Gamma_{\kappa}^{R_0} &= \frac{\partial R_0}{\partial \kappa} \times \frac{\kappa}{R_0} = 1 \\
 \Gamma_{\alpha}^{R_0} &= \frac{\partial R_0}{\partial \alpha} \times \frac{\alpha}{R_0} = -\frac{\alpha}{\mu + \alpha + \gamma} \\
 \Gamma_{\gamma}^{R_0} &= \frac{\partial R_0}{\partial \gamma} \times \frac{\gamma}{R_0} = -\frac{\gamma}{\mu + \alpha + \gamma} \\
 \Gamma_{\mu}^{R_0} &= \frac{\partial R_0}{\partial \mu} \times \frac{\mu}{R_0} = -\frac{\mu}{\mu + \alpha + \gamma} + \frac{\mu(\eta - \eta\rho)}{(\mu + \eta\rho)(\mu + \eta)} \\
 \Gamma_{\rho}^{R_0} &= \frac{\partial R_0}{\partial \rho} \times \frac{\rho}{R_0} = -\frac{\eta\rho}{\mu + \eta(1 - \rho)} \\
 \Gamma_{\eta}^{R_0} &= \frac{\partial R_0}{\partial \eta} \times \frac{\eta}{R_0} = -\frac{(1 - \rho)\mu\eta}{(\mu + \eta)(\mu + \eta(1 - \rho))} \tag{15}
 \end{aligned}$$

The reproduction number R_0 increases as the average number of contacts between individuals per unit time and the average number of sexual partners increases. On the other hand α, γ, ρ and η are inversely proportional to R_0 . This implies that, increasing them would decrease the R_0 even when the effects are not extreme. This calls for enhancement of protective measures such as Vaccination, screening, practising abstinence, having limited number of sexual partners at any age, using condoms for every sexual encounter, not starting having sex and young age and adopting a healthy lifestyle to strengthen the immune system to help reduce new HPV and cervical cancer infections.

8 Conclusion

Protection is the most promising intervention against HPV and cervical cancer infection especially in the scarce resource setting. Screening and vaccination are effective in prevention of the disease induced mortality rate. Moreover practising abstinence, having limited number of sexual partners at any age, using condoms for every sexual encounter, not starting having sex and young age and adopting a healthy lifestyle to strengthen the immune system will reduce the probability of infection hence resulting to less people contacting the infection. HPV and cervical cancer prevention is effective as it leads to a very small fraction of individuals in a given population progressing to infective stage. Thus, the importance of combination of prevention approaches to the transmission dynamics of HPV infection.

References

- [1] **Abdulsamad E. S. (2019)**. Mathematical Modeling of Cervical Cancer with HPV Transmission and Vaccination. *Science Journal of Applied Mathematics and Statistics*. Vol. 7, No.2 pp. 21-25. doi: 10.11648/j.sjams.20190702.13
- [2] **Bruce RL, Stewart FM (2002)**. Epidemiology, evolution and future of the HIV pandemic. *J. Math. Biosci.* 2002;363:2587-2599.
- [3] **Castillo-Chavez C, Blower S, Van D. P, Krirschner D, Yakubu A. 2002.)** Mathematical approaches for emerging and re-emerging infectious diseases: An introduction. *The IMA Volumes in Mathematics and its Applications*. Springer-Verlag, New York;
- [4] **Castillo-Chavez, Feng Z. and Huang W.(2001)**. On the Computation of R_0 and its Role on Global Stability, M-15553.
- [5] **Chitnis N, Hyman J, Cushing J, (2008)**. Residual viremia in treated HIV+ individuals *Epidemiology*. *PLOS Computational Biology*. 2008;12:597-677
- [6] **Clifford G. M., Smith, J. S., Plummer, M., Munoz, N., and Franceschi, S. (2003)**. Human papillomavirus types in invasive cervical cancer worldwide: a meta-analysis. *British journal of cancer*, 88(1), 63-73.
- [7] **De Leon C.V.(2009)**. Constructions of Lyapunov Functions for Classics SIS, SIR and SIRS epidemic model with variable population size,

Unite Academicade Mathematicas, UniversidadnAutonoma de Guerrere,
Mexico Facultadde Estudios Superiores Zaragoza, UNAM, Mexico.

- [8] **Diekmann, O., Heesterbeek, J., Metz J.A.(1990)**. On the definition and the computation of the basic reproduction ratio in models for infectious diseases in heterogenous populations. *Journal of Mathematical Biology*. 167, 67-78.
- [9] **Gyenwali D., Khanal G., Paudel R., Amatya A., Pariyar J. and Sharad R. O.. (2014)**. Estimates of delays in diagnosis of cervical cancer in Nepal. *BMC Women's Health* , 14:29
- [10] **Hughes, J. P., Garnett, G. P., and Koutsky, L. (2002)**. The theoretical population-level impact of a prophylactic human papilloma virus vaccine. *Epidemiology*, 13(6), 631-639.
- [11] **Kai Z., Xinwei W., Hua L., Yunpeng J., Qiuwei P., Yumei W. and Ming M. (2020)**. Mathematical analysis of a human papillomavirus transmission model with vaccination and screening. *Mathematical Biosciences and engineering*. Research article. MBE, 17(5). DOI: 10.3934/mbe.2020294.
- [12] **Lee S. L., and Tameru, A. M. (2012)**. A mathematical model of human papillomavirus (HPV) in the United States and its impact on cervical cancer. *Journal of Cancer*, 3, 262.
- [13] **Nwabuisi U.J , Mbah G.C.E , Ukwueze U.R , Okoh C.N (2020)**. A Mathematical Model of Transmission Dynamics of Human Papiloma Virius (Hpv). *IJSAR Journal of Mathematics and Applied Statistics (IJSAR-JMAS)* ISSN: 2408-7637 Volume 7, Issue 1.147- 157
- [14] **Nyimvua S. and Hawa M. (2014)**. Modelling the Impact of Vaccination and Screening on the Dynamics of Human Papillomavirus Infection. *Int. Journal of Math. Analysis*, Vol. 8, no. 9, 441 - 454
- [15] **Opoku O.K.N. , Nyabadza F. and Ngarakana-Gwasira E. (2019)**. Modelling cervical cancer due to human papillomavirus infection in the presence of vaccination. *open journal of mathematical sciences*. DOI: 10.30538/oms.0065
- [16] **Parkin D. M., Láárá, E., and Muir, C. S. (1988)**. Estimates of the worldwide frequency of sixteen major cancers in 1980. *International journal of cancer*, 41(2), 184-197.
- [17] **Routh E.,(1977)** A Treatise on the Stability of a Given State of Motion: Particularly Steady Motion, *Macmillan Publishers*.

- [18] **Usman S., Adamu I. I. and Tahir A.(2016)**. Mathematical model on the impact of natural immunity,vaccination,screening and treatment on the dynamics of human papillomavirus infection and cervical cancer.*Katsina Journal of Natural and Applied Sciences* Vol. 5 No. 2 September,(ISSN: 2141-0755)
- [19] **Waggoner S.E. (2003)**. Cervical cancer. *Lancet*, 361(6):2217–2225