

Techno Economic Assessment of Axial Flow Pumps in Thrissur Kole lands

ABSTRACT

Water-logged areas of wetland paddy systems must be drained in the shortest time to initiate seed bed preparation. The short time for seed bed preparation demands the adoption of low head-high discharge pumps for draining the field. A typical example of a water-logged wetland paddy system is the Kole lands lying in the Thrissur and Malappuram districts. Dewatering from these fields is mainly done by 'petty and para' pump, a locally made crude form of axial flow propeller pump. The petty and para pump has very low overall efficiency and requires significant installation cost and maintenance cost. Thus, as an alternative to this pump, modern axial flow pumps such as vertical submersible and vertical turbine type are gradually replacing them. At the same time, this replacement operations are capital intensive. Hence, it is necessary to assess the hydraulic and economic performance of the modern pump sets with the traditional one. Therefore, this study was conducted on the axial flow pumps in operation in the Kole lands of Thrissur District in Kerala, India, during the year 2020-2022. Performance evaluation of 50 hp petty and para pump, vertical submersible pump and vertical propeller pump was done through field pumping test and the economic analysis was carried out by considering the capital costs, operation and maintenance costs and the benefits derived from the paddy cultivation. The study revealed that overall efficiency of 50 hp petty and para pump varied from 18.51 to 22.64 percent, with a mean of 20.58 percent. In the case of vertical submersible pump, the same varied from 54.46 to 60.48 percent with a mean of 57.47 percent and in the case of propeller pump it ranged from 42.67 to 50.69 percent with a mean of 46.68 percent. It is evident that vertical submersible pump has the highest Benefit-Cost Ratio (BCR), Net Present Worth (NPW), Internal Rate of Return (IRR), and the lowest Payback Period (PP) and pumping costs among the three 50 hp axial flow pumps.

Keywords: Kole lands; axial flow propeller pump; petty and para pump; vertical submersible pump; vertical propeller pump

1. INTRODUCTION

Rice production in the coastal districts of Kerala and particularly the low-lying areas of this region of India is heavily dependent on water management measures, particularly drainage requirements. The system of drainage of water from the bunded rice fields during the crop season is a unique aspect of paddy production process in these areas. Paddy is cultivated in the lowland regions of Kerala, such as Kuttanad, Kole lands, and Pokkali are places situated below MSL. The Kole lands known as the rice granary of Thrissur and Malappuram districts, is located in the central part of Kerala.

Kole lands in Thrissur and Malappuram districts is spread out in Thrissur, Chavakkad, Mukundapuram and Ponnani taluks [1]. The terrain with a saucer-like topography of Kole

lands lies at 0.50 to 1.50 m below MSL [2]. Kole lands cover an area of about 10326 ha in Thrissur district and the same is called 'Thrissur Kole' which is divided into Thrissur North Kole and Thrissur South Kole. North Kole covers 8057 ha and south Kole occupies 2269 ha. The land is very fertile, contains a lot of humus as it receives surface runoff from the surrounding elevated areas. The paddy productivity of Kole lands has been reported to be two to three times the average productivity of other Kerala wetland paddy systems [3].

The waterlogged areas must be drained as soon as possible to begin seedbed preparation because of the limited time available for land preparation. The low head-high discharge pumps are used for the drainage of the paddy fields in the Kole lands. If water is impounded for an average height of two meters over the entire Kole fields, it is estimated that more than 200 Mm³ of water per year is to be drained from the area before each cultivation season. There are 315 axial flow pumps operating in Kole lands, which can be primarily divided into three categories viz, Petty and Para Pumps (PPP), Vertical submersible Pumps (VSP) and Vertical Propeller Pumps (VPP). Out of these, 239 are PPP, 54 are VSP and 22 are VPP.

PPP, a crudely built and locally made axial flow propeller pump is the major type of pump used to dewater the Kole fields. Even though it serves the purpose of dewatering, it is highly hydraulically inefficient. Its overall efficiency is less than 30 percent and requires significant installation, operation and maintenance cost and energy consumption [2]. When the water level in the sump drops, additional para should be fitted in order to continue the pumping operation. Before the onset of southwest monsoon, pump need be dismantled and stored in a safer place to avoid damages in the event of submergence. Thus, the operation and upkeep of petty and para is hectic and laborious in addition to the periodic incurring of cost. However, farmers continued to use petty and para because of the Government's incentives for its installation, maintenance and electricity charges. Some areas of the Kole lands, farmer groups have started employing factory made vertical propeller pumps and vertical submersible pumps having more hydraulic efficiency and easier to operate and maintain. The hydraulic performance and internal flow characteristics of the axial flow pump have been investigated in a number of researches, in particular in [4] and [5]. Previous study confirm that the axial flow pumps consume less energy and economically efficient compared to conventional centrifugal pump [6]. The axial flow pump's efficiency was experimentally studied and the result show that the axial flow pump's highest efficiency is 82.09 percent [7]. These types of pumps ensure saving of electricity charges, operation and maintenance costs and long years of trouble-free operation. At the same time, replacement of petty and para pump with modern axial flow pumps is capital intensive. Hence, a study was conducted to assess the performance of petty and para pumps, vertical submersible pump and vertical propeller pump with respect to its efficiency and cost economics.

2. MATERIALS AND METHODS

2.1 Study area

The study was conducted in the low-lying paddy fields of the Thrissur district in Kerala, and this area is known as Kole lands. This area is located between 10°17'N to 10°37'N latitudes and 76°05'E to 76°15'E longitude. The elevation of the land ranges from 1 to 1.5 m above MSL. Tropical humid climate prevails in Kole lands. The area has an average minimum and maximum temperature of 21 °C and 38 °C. As in other parts of the state, Kole lands also receives two well-defined rainy seasons, viz. the South-West and North-East Monsoons.

The average annual rainfall recorded in the Kole lands is 2685mm and the average evaporation in the Kole land is 4.2 mm per day. Total area of Kole land comes to 10325.5 ha. The location map of the study area is shown in Fig.1.

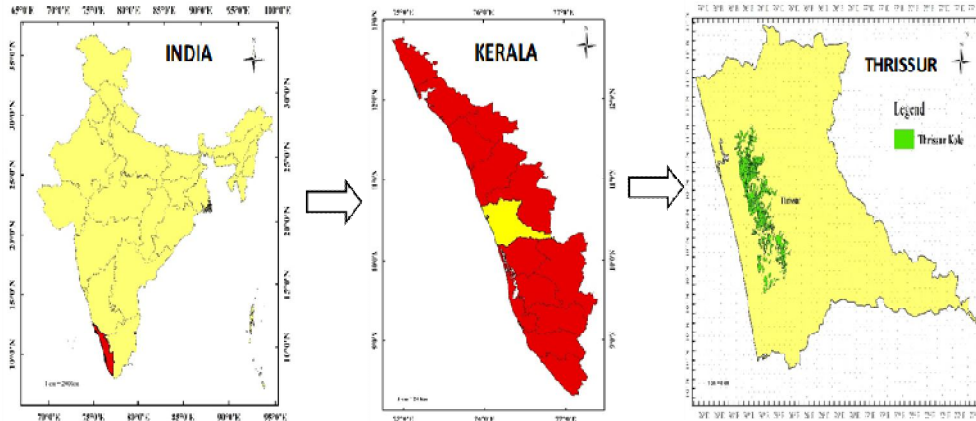

Fig.1 Location map of Thrissur Kole lands

2.2 Details of axial flow pumps operating in Thrissur Kole lands

Three different types of axial flow pumps are in operation in Thrissur Kole lands. They are Petty and Para Pumps, Vertical Submersible Pumps and Vertical Propeller Pumps.

2.2.1 Petty and para pump (PPP)

The most commonly used dewatering pumps in Kole lands is the petty and para. The majority of petty and para are powered by motors ranging from 20 to 100 hp, with 50 hp being the most common one. It is an indigenous form of axial flow propeller pump. The impeller revolves inside the cylindrical hardwood drum called 'Para'. Due to the rotation of the impeller, the water gets pressurized and rushes axially upward via 'Para', turns 90 degrees, and exits through a horizontal, rectangular wooden outlet called 'Petty'. The impeller is made of cast iron, and the vanes are made of mild steel. Three to six vanes can be found on an impeller. The blades are attached to the impeller shaft, which is composed of mild steel. A flat quarter turn belt with a length of 6 to 10 m and a width of 20 cm drives the impeller shaft [8]. Components of 50 hp petty and para pump is shown in Fig 2 (a).

2.2.2 Vertical submersible pump (VSP)

The shaft of a vertical submersible pump is made of stainless steel and is powered by a dry type induction motor. Cable glands enable four-stage sealing, which guarantees a pressure-resistant, moisture-proof seal even when the sheath is damaged. It also provides a dry environment for the pump. To prevent the pump from overheating and losing power, the motor's thermal overload protection is used. An oil chamber is fitted to lubricate and cool the mechanical parts efficiently. The parts of a 50 hp vertical submersible pump is shown in Fig. 2 (b).

2.2.3 Vertical propeller pump (VPP)

A vertical propeller pump consists of a bowl assembly, a column assembly, and a drive unit assembly. A bell mouth arrangement is made to allow water to enter steadily with minimum loss as possible. The pump's shaft is made of high-tensile steel. Flow from the column pipe

to the delivery pipe is directed by the discharge head [9]. Fig.2 (c) shows components 50hp vertical propeller pump.

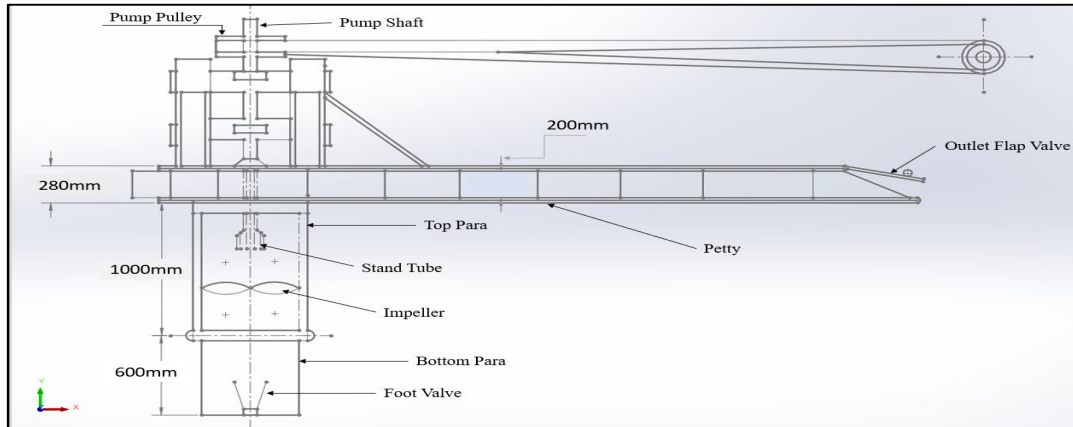

(a)

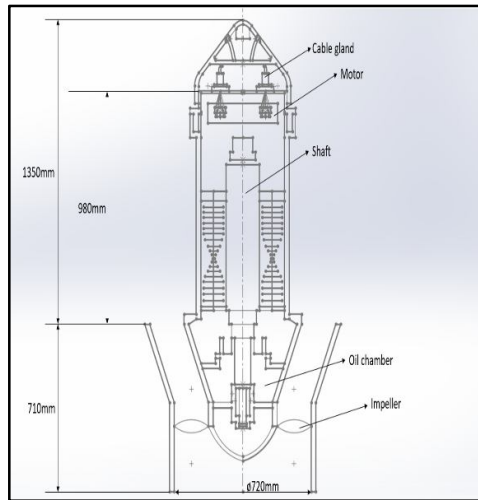

(b)

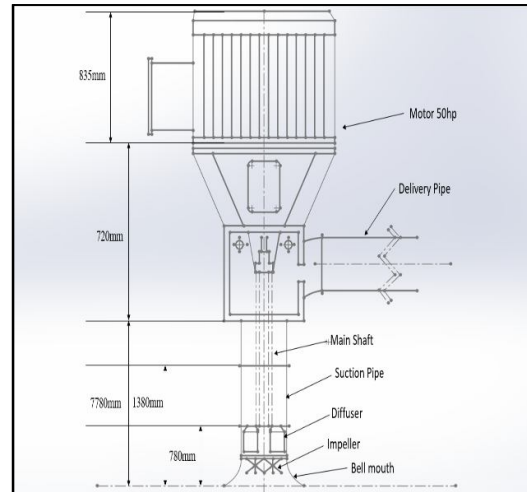

(c)

Fig. 2 (a) Components of petty and para pump (b) Components of vertical submersible pump (c) Components of vertical propeller pump

2.3 Evaluation of the characteristics of axial flow pumps

Petty and para pump of 50 hp installed at Sangam Kole Padasekharam (Puzhakkal block panchayath), 50 hp vertical submersible pump installed at Anthikadpadasekharam (Anthikad block panchayath) and 50 hp vertical propeller pump installed at Jubilee Tevarpadavu (Cherpublock panchayath) of Thrissur district were selected for performance evaluation. The performance was evaluated by field pumping test. In order to carry out the pumping test, petty and para pump and vertical submersible pump were operated continuously for 8 hours and vertical propeller pump was operated continuously for

15 days. Observations on head, discharge, current, voltage and power were taken during the test.

2.3.1 Head calculation

The static head of petty and para was measured from the water level in the sump to the center line of the petty using a measuring tape. For vertical submersible pump and vertical propeller pump, it was measured from the water level in the sump to the center line of the delivery pipe. The total head was calculated by adding frictional loss and velocity head to the static head. Head loss due to friction was calculated using Darcy-Weisbach equation

$$H_f = \frac{4flv^2}{2gd} \quad (1)$$

Where, f=Friction factor

l =Length of pipe(m)

v=Flow velocity(ms⁻¹)

g= Acceleration due to gravity (m²s⁻¹)

d= Inside diameter of the pipe (m)

(For the petty side 'd 'was taken as the width of petty). Flow through the pipe was turbulent so friction factor was calculated using the equation[10]

$$f = \frac{0.316}{Re^{0.25}} \quad (2)$$

where, Re=Reynolds number

Reynolds number was calculated using the equation

$$Re = \frac{vd^2}{\nu} \quad (3)$$

Where v= Flow velocity (ms⁻¹)

d= inside diameter of the pipe (m)

ν= Kinematic viscosity

$$\text{Velocity head} = \frac{v^2}{2g} \quad (4)$$

2.3.2 Discharge measurement

Discharge of petty and para pump was measured by area- velocity method. Discharge from the pump was diverted to an open channel of length 20 m, width 1.43 mand depth 1.5 m. A vertical axis current meter was placed across the channel to measure the flow velocity. Discharge in m³s⁻¹ was calculated using the equation

$$Q = av \quad (5)$$

Where,

Q= Discharge (m³s⁻¹)

a=Area of cross-section of the channel (m²)

v=Flow velocity (ms⁻¹)

Area (m²) =Channel width (m)×Channel depth(m)

Discharges of the vertical submersible pump and vertical propeller pump were measured using a portable ultrasonic flow meter at varying heads. TransPort PT 900 portable ultrasonic flow meter was used for the discharge measurement (Fig.3).



Fig.3 Ultrasonic flow meter mounted on the delivery pipe of vertical submersible pump

2.3.3 Power measurement

Input voltage and input current were measured by connecting the clamp meter to the input supply. The power factor was measured from the energy meter. Input Horse Power was calculated using the equation as follows

$$\text{Input Horse Power (IHP)} = \sqrt{3}VI\cos\phi \quad (6)$$

Where,

V=Voltage (V)

I=Current (A)

$\cos\phi$ =Power factor

Water Horse Power was calculated using the equation

$$\text{Water Horse Power (WHP)} = \frac{QH}{76} \quad (7)$$

where,

Q=Discharge(lps)

H=Total head (m)

Overall efficiency of the pump was calculated using the equation

$$\text{Overall efficiency of the pump} = \frac{\text{WHP}}{\text{IHP}} * 100 \quad (8)$$

2.4 Economic analysis of axial flow pumps

The capital investment costs, operating costs, and benefits obtained from the cultivation of paddy using axial flow pumps were estimated. **The economic analysis was performed using indicators**, Benefit-Cost Ratio (BCR), Net Present Worth (NPW), Internal Rate of Return (IRR) and Payback Period (PP). The investment costs include the cost of the pump and installation cost. The operating costs include operation and maintenance costs, cost of electricity, cost of cultivation, and operator's wage. The benefit is the income obtained from the cultivation of paddy from the dewatered area. The basic data required for the estimation were collected by field survey.

Operation and maintenance cost of 50 hp petty and para includes the cost to dismantle the petty and para before the southwest monsoon season, the cost to assemble and install the petty and para after the monsoon, the cost of applying fish oil on the petty and para and the cost to change the belt and bearings. There is no maintenance cost for 50 hp vertical submersible pumps and 50 hp vertical propeller pumps for the first two years of the warranty period. Thereafter up to 10 years, annual maintenance cost is considered as 0.5 percent of the cost of pump and for the next 10 years it was taken at 1.0 percent of the total cost of pump [9]. The cost of electricity for pumping was calculated by considering the average annual energy consumption of each axial flow pump. The cost of cultivation per ha was calculated by considering the costs of field preparation, fertilizer application, plant protection and harvesting cost.

2.4.1 Benefit-Cost ratio (BCR)

It is the ratio of present worth of the benefits (cash inflows) to the present worth of the costs (cash outflows).

$$\text{Benefit-Cost ratio (BCR)} = \frac{\sum_{t=1}^n \frac{B_t}{(1+i)^t}}{\sum_{t=1}^n \frac{C_t}{(1+i)^t}} \quad (9)$$

where,

B_t = Benefit accrued in each year of project period in rupees

C_t = Cost incurred in each year of project period in rupees

t = Number of the year of operation of the project during the general period of such operation.

n = Number of years of anticipated project life (20 years).

i = Discount rate selected on the basis of cost of capital (10 percent).

2.4.2 Net Present Worth (NPW)

The difference between the present worth of the benefits (cash inflows) and costs (cash outflows) over time is known as NPW.

$$\text{Net Present Worth} = \sum_{t=1}^n \frac{B_t - C_t}{(1+i)^t} \quad (10)$$

2.4.3 Internal Rate of Return (IRR)

IRR is the annual discount rate at which the present worth of two streams of cash-flow are equal or the discount rate at which net present worth is equal to zero.

$$\sum_{t=1}^n \frac{B_t - C_t}{(1+i)^t} = 0 \quad (11)$$

2.4.4 Payback Period (PP)

The payback period is the number of years required to recover the original cash investment.

$$\text{Payback Period} = \frac{\text{Investment}}{\text{Cash flow per year}} \quad (12)$$

2.4.5 Cost of pumping of axial flow pumps

Estimation of the cost of pumping is essential to compare the relative cost of different types of pumping installations. The cost of pumping per year of 50 hp petty and para, vertical submersible, and vertical propeller pumps were calculated by considering the fixed and variable costs of pumping. Fixed costs include annual interest cost and depreciation. Variable costs include electricity cost, operation and maintenance cost, and operator's wages. Depreciation was calculated using the straight-line method. The annual interest rate was taken as 10 percent. Petty and para pump has a useful life of seven years, and the useful life of the vertical submersible pump and vertical propeller pump is taken as 20 years.

3. RESULTS AND DISCUSSION

3.1 Performance evaluation of axial flow pumps

A 50 hp petty and para pump was tested at different operating heads. The performance curve of the pump was plotted with discharge (m^3h^{-1}) against the head, Input Horse Power (IHP) and overall efficiency as shown in Fig.4. The pump discharge varied from 2,172.46 to 1,153.15 m^3h^{-1} when the total head varied from 0.98 to 1.82 m. During this, the pump's

overall efficiency dropped from a maximum of 22.64 to 18.51 percent, with a mean value of 20.58 percent. The overall efficiency increased (18.51 to 22.64 percent) as the head increased (0.9 to 1.36 m) and reached a maximum of 22.64 percent. The pump showed a discharge of 1834.75 m³h⁻¹ and IHP of 40.18 hp, when the head was 1.36 m, and thereafter, the further increase in the head from 1.36 to 1.82 m decreased the efficiency from 22.64 to 19.26 percent.

The performance characteristics curve of vertical submersible pump is shown in Fig.5. When the total head varied from 2.9 to 3.56 m, the pump discharge decreased from 2,282 to 2,141 m³h⁻¹. The pump showed an efficiency of 54.46 percent against the highest discharge of 2,282 m³h⁻¹ and a total head of 2.9 m. The overall efficiency topped to the maximum value of 60.48 percent against the total head of 3.56 m, and a discharge rate of 2,141 m³h⁻¹. The input power corresponding to this efficiency was 46.04 hp. The pump's overall efficiency varied from a maximum of 60.48 to a minimum of 54.46 percent, with a mean value of 57.47 percent.

The vertical propeller pump's performance characteristics curve is depicted in Fig.6. Total head varied from 2.16 to 3.23 m. The pump discharge varied from 2,090 to 1,820 m³h⁻¹. The pump's overall efficiency dropped from a maximum value of 50.69 to a minimum value of 42.67 percent, with a mean value of 46.68 percent. The overall efficiency increased (from 42.67 to 50.69 percent) as the head raised (from 2.16 to 2.75 m) and reached a maximum of 50.69 percent. The discharge of the pump was 1967 m³h⁻¹ when the head reached 2.75 m and the input power corresponding to this head was 39.02 hp. Thereafter, for the further increase in the head from 2.75 to 3.23 m, efficiency decreased from 50.69 to 47.95 percent.

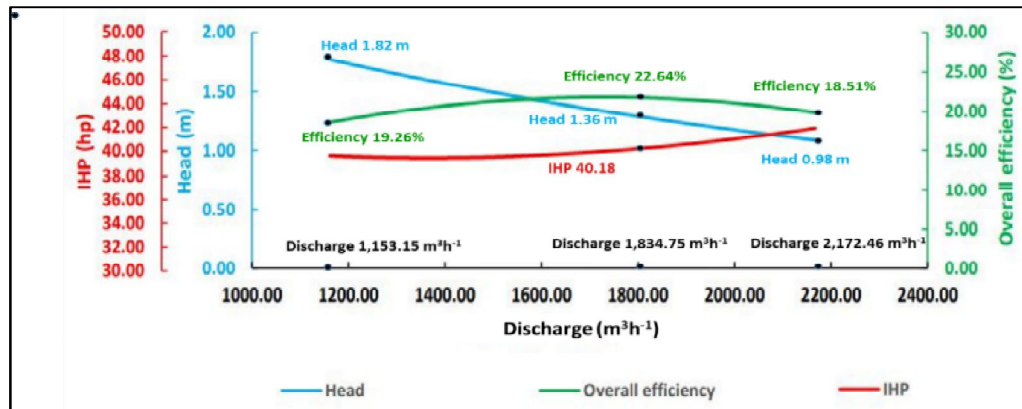

Fig.4 Performance curve of 50 hp petty and para pump

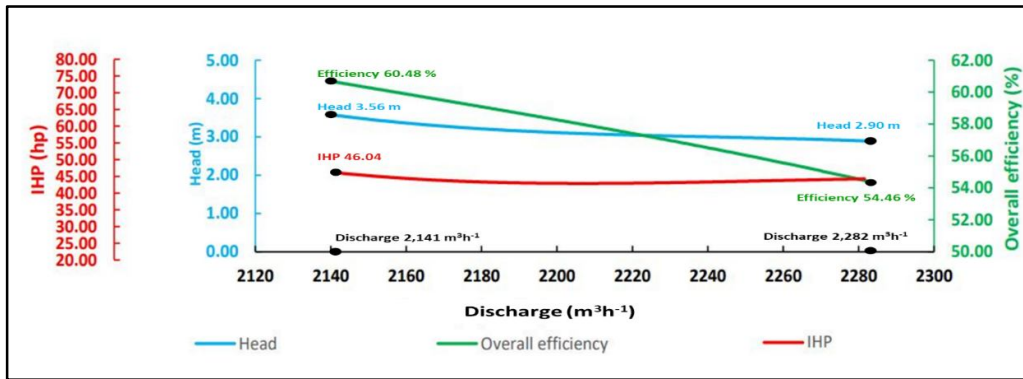

Fig.5 Performance curve of 50 hp vertical submersible pump

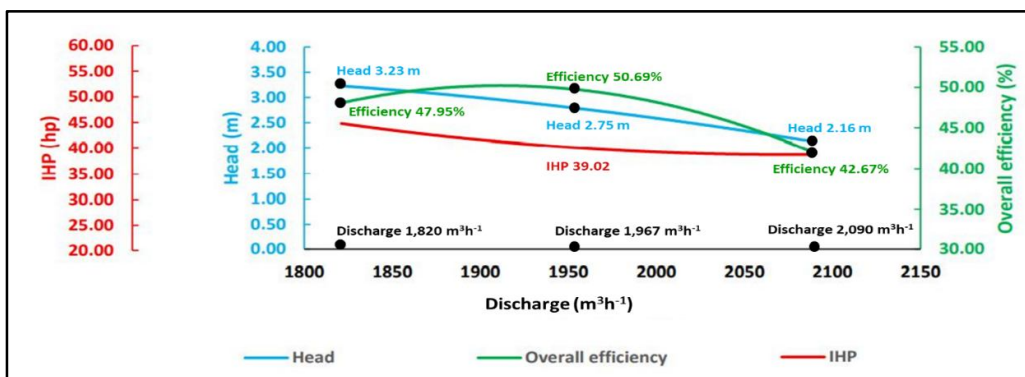

Fig.6 Performance curve of 50 hp vertical propeller pump

3.2 Economic analysis of axial flow pumps

The BCR, NPW, IRR and PP with respect to petty and para pump (PPP), vertical submersible pump (VSP) and vertical propeller pump (VPP) were calculated and the results are shown in Table 1.

Table 1 Results of economic analysis of various pumps

SI no	Parameters	PPP	VSP	VPP
1	BC ratio	1.66	2.02	1.99
2	NPW (₹ in lakhs)	164.0	517.8	456.2
3	IRR (%)	238	329	319
4	PP (years)	0.95	0.30	0.31

Among the three axial flow pumps, the 50 hp vertical submersible pump has the highest BCR, which was 2.02, followed by the vertical propeller pump, which was 1.99, and the petty and para pump, which has the lowest BCR (1.66). Similarly, the NPW value for the vertical submersible pump was the highest, and it was ₹ 517.8 lakhs. The vertical propeller pump's NPW value was ₹ 456.2 lakhs, and the NPW of petty and para was ₹ 164.0 lakhs. The IRR of petty and para was 238 percent, whereas it was 329 percent for vertical submersible pump, and 319 percent for vertical propeller pump. The PP for the 50 hp vertical submersible, vertical propeller, and petty and para pumps were 0.30, 0.31 and 0.95 years respectively. The results of the economic analysis showed that the operation of vertical submersible pumps and vertical propeller pumps was economically more viable than petty and para pumps.

The cost of pumping per year & per ha of 50 hp petty and para pump, vertical submersible pump, and vertical propeller pump were calculated and are shown in Table 2. The cost of pumping in a year was ₹ 9.64 lakhs for 50 hp petty and para, whereas it was ₹ 6.95 lakhs for 50 hp vertical submersible pump and ₹ 7.21 lakhs for 50 hp vertical propeller pump. The cost of pumping per ha for 50 hp petty and para pump, vertical submersible pump, and vertical propeller pump were ₹ 25,707, ₹ 7,502 and ₹8,702 respectively. The results showed that the installation of vertical submersible pump and vertical propeller pumps were more economic than petty and para pump.

Table 2 Cost of pumping of axial flow pump

Sl no	Cost heads	Types of pumps		
		PPP	VSP	VPP
Fixed cost				
1	Annual interest cost (₹)	55,000	1,21,000	1,10,000
2	Annual depreciation (₹)	1,28,571	99,000	90,000
Variable cost				
3	Cost of electrical energy (₹)	4,92,490	2,49,543	2,92,060
4	Operation and maintenance cost (₹)	50,000	16,500	15,000
5	Operator's wages (₹)	1,80,000	1,80,000	1,80,000
6	Cost of pumping/year(lakhs)	9.64	6.95	7.21
7	Cost of pumping per ha (₹)	25,707	7,502	8,702

4. CONCLUSIONS

A study was conducted to assess the efficiency and cost economics of various axial flow pumps operating in the low-lying paddy fields of Thrissur district known as Kole lands. Among the three different types of 50 hp axial flow pumps considered for the study, the vertical submersible pump has given the highest overall efficiency, BCR, NPW, and IRR, followed by the vertical propeller pump and petty and para pump. The PP and cost of pumping of vertical submersible pumps were also the lowest. Considering the hydraulic efficiency, energy consumption, and economics of pumping, it is recommended that the water management system in Kole lands will be more efficient, if all petty and para pumps are replaced with modern axial flow pumps in the near future.

REFERENCES

1. Johnkutty, I. and Venugopal, V. K. Kole lands of Kerala. Kerala Agricultural University, Vellanikkara, Thrissur; 1993.
2. Ayisha, M., Jayan, P. R., Nithin, J. G., and Saranya, R. N. Efficiency improvement of an axial flow propeller pump for dewatering in kole lands of Kerala, India. *Int.J.Appl.and pure Sci.and Agr.* 2016;2(5):1-6.
3. Srinivasan, J. T. An economic analysis of paddy cultivation in the Kole land of Kerala. *Indian J. of Agri. Econ.* 2012; 67(2): 213.
4. Zhang, H., Shi, W. D., Bin, C., Zhang, Q. H., & Cao, W. D. Experimental study of flow field in interference area between impeller and guide vane of axial flow pump. *J. of Hydrodynamics, Ser. B.* 2015;26(6):894-901.
5. Cao, W., & Li, W. Study on the performance improvement of axial flow pump's saddle zone by using a Double inlet nozzle. *Water*, 2020; 12(5):1493.
6. Krupnik, T. J., Valle, S. S., Islam, S., Hossain, A., Gathala, M. K. and Qureshi, A. S.

Energetic, hydraulic and economic efficiency of axial flow and centrifugal pumps for surface water irrigation in Bangladesh. *Irrig.and Drain.* 2015;64(5): 683-693.

7. Qian, Z., Wang, F., Guo, Z., & Lu, J. Performance evaluation of an axial-flow pump with adjustable guide vanes in turbine mode. *Renewable Energy*, 2016;99: 1146-1152.
8. Jaikumar, U., Shyla, J., Arshana, V. K., and Varun,E.A. Status of drainage pumping system in Thrissur Kole lands. Kerala Agricultural University, Vellanikkara, Thrissur;2014.
9. Michael, A.M..Irrigation theory and practice. Vikas publishing house Pvt Ltd, Noida,2008.
- 10.Gravelle, R. Discharge estimation: Techniques and equipment. *Geomorphological techniques.* 2015; 5, 1-8.

