

Design and Fabrication of Mechanical Sieve Shaker for Particle Size Analysis of Ceramics

ABSTRACT

A mechanical sieve shaker machine for particle size analysis of ceramics and related powders was successfully designed, fabricated and tested. This machine works on the principle of reciprocation where a to-and-fro motion is responsible for the agitation of the separating particles. All materials used for the fabrication were carefully sourced locally without compromising quality and selected to suit the working conditions of the sieve machine. A test run carried out showed that the sieve shaker effectively separated particles of various sizes hence, produced reliable and efficient results. The obtained particle sieving efficiency amounts to about 97 %. However, the locally fabricated mechanical sieve shaker cannot effectively sieve large-size particles, but can optimally sieve particle size of the order of 0.1 to 1.0 mm. The cost of production per one is about sixty-five thousand naira, ₦65,000 (156 USD), which is adjudged cost effective when compared to the market value, ₦95,000 (228 USD) of the imported one at the time of production.

Keywords: Sieve shaker, particle size, ceramics, sieving efficiency

1. INTRODUCTION

The particle size distribution (PSD) of powders, pulverized clays, soil aggregates, granular materials, dispersed particles in fluid, etc. describes the quantity of particles by mass according to size present[1]. It is applicable to solid materials, suspension, emulsions and even aerosols[2]. Particle size analysis is used to characterize the size distribution of particles in a given sample. There are many different methods employed to determine particle size and they include sieve analysis, air elutriation analysis, photo analysis, optical counting methods, electro resistance counting methods, sedimentation techniques and laser diffraction methods. Some of these particle sizing methods can be used for a wide range of samples while some can only be used for a specific application. In any industry where milling or grinding is utilized such as a ceramic industry, particle size is a critical factor in determining the efficiency of the manufacturing processes and performance of the final product[2]. Other industries and product types where particle sizing is applicable include pharmaceuticals, building materials, paints and coatings, food and beverages, aerosols, etc.

Laser particle-size analysis (LPSA) and sieve analysis are presently the two types of particle-sizing techniques that are usually used in the industry[3]. LPSA determines PSD of a given sample electronically by measuring the intensity of light scattered as a laser beam passes through a dispersed-particulate sample[3], [4]. The angle of scatter of the laser light is inversely proportional to the particle size. The angle of scatter of the laser light is inversely proportional to the particle size. The angular intensity of light scattered is captured by a series of photosensitive detectors. The data are then processed and analyzed through the instrument software using the Mie theory to calculate the particle sizes[4].

Sieve analysis or simply sieving is one of the oldest PSD methods and it is frequently used because of its simplicity, cheapness, and ease of interpretation. It is a unit operation carried out by allowing solid particles of different sizes or grades to pass through the pores of an orderly arranged set of stacked sieves in a manner of the particle sizes

and shape [5]. Manual sieving (use of hand) of materials is tasking, time wasting and tedious, hence the use of mechanical shakers which makes the process simpler and easier. There are six major types of commercial mechanical sieve shakers [6] and they differ by design, type and nature of the agitating forces applied during sieving operation. These commercial mechanical sieve shakers are Tyler Ro-Tap, Gilson SS-15, KS 300, Digital, Heavy-Duty and Octagon sieve shakers.

The aim of this study is to design and locally fabricate a mechanical sieve shaker for particle size analysis of ceramic powders with high efficiency and cost effective when compared to the imported ones.

1.1 Operation of a typical mechanical sieve shaker

Sample particles to be sieved are first separated into individual grains, cleaned, dried, and weighed. They are then placed into the top bowl of the stacked sieves arranged in decreasing order of opening sizes, with the coarsest sieve at the top and finest sieve at the bottom. The stack is then loaded into the stack holder and constrained by the stack cap. As the motor is turned on, energy is transferred to the shaft with the attached disc - sieve bases assembly [7]. As the bases rotate (axial motion), the sieves are subjected to a reciprocating up- and-down motion. It is this reciprocating vertical motion that leads to the sieving action. As the frequency of the vertical motion (agitating action) is increasing, a loss of contact between sample and the sieve chamber occurs thereby causing the smaller loose particles to pass through the sieve of a higher opening into a lower sieve (low opening size sieve) [8], [9].

Upon completion of the oscillation of the mechanical shaker after about 5-15 minutes, the sieve stacks are removed and carefully disassembled. The mass of the sample retained in each sieve is determined by weighing while the percentage of sample that passed through each sieve is equally determined [8]. The percentage passing is then calculated by subtracting the cumulative percent retained from one hundred percent (100 %). From the calculated results, a semi-logarithmic curve is plotted with the ordinary axis (arithmetic) being the cumulative passing percent and the aperture size (sieve opening) as abscissa (logarithmic scale) [6].

2. MATERIAL AND METHODS

This section is segmented into five, viz: materials and sourcing, design, fabrication, electrical connection and finishing. The research algorithm is as presented in Figure 1.

2.1 Materials and sourcing

The basic materials that were used in the fabrication of the mechanical sieve shaker is listed in Table 1. Bearing in mind the problems associated with materials selection in engineering practice, the excellent mechanical and physical properties, and other factors exhibited by these materials in service were considered. These properties include but not limited to high mechanical strength, ductility, stability, fabricability, availability, corrosion resistance, cost effective, weldability, machinability and weight [10], [11]. These materials were locally sourced within the markets in the South East region of Nigeria.

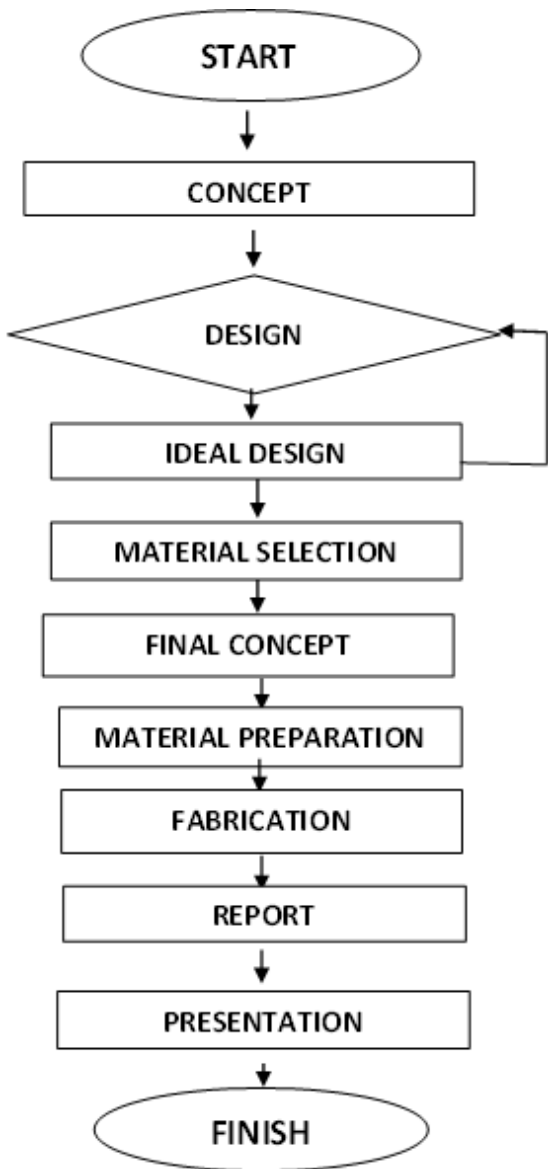

Fig. 1. Research algorithm

Table 1. Basic materials used and parts of the shaker

S/N	Name of part	Materials used
1	Frame work(casing)	Mild steel (sheet metal & angle bar)
2	Pulley	High carbon steel
3	Bolts and nuts	Mild steel
4	Belts	Rubber/leather
5	Bearings	Ball bearing
6	Upper case (sieving unit)	3mm transparent polyester sheet
7	Electric motor	1 Horse power single phase electric motor
8	Power cable	PVC coated cable
9	Springs	High carbon steel
10	Resistor	Variable dimmer switch
11	Shaft	High carbon steel
12	Wire mesh	Chromium coated sieves of different apertures
13	Chromium paint	For surface finishing
14	Fuse	4 amps fuse

2.2 Design

The conceptualized idea was designed and drawn with detailed features as shown in Figure 2.

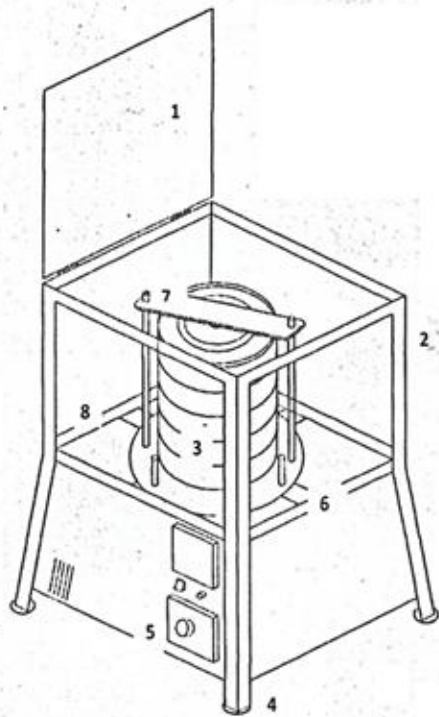

Key:

1. Cover
2. Frame
3. Sieve stack
4. Stand
5. Control board
6. Shaker base
7. Clamp
8. Polyester sheet

Fig. 2. Design and assembly of the mechanical sieve shaker

2.3 Fabrication

The sourced materials were taken to the welding workshop of Metallurgical Engineering Technology Department, Akanu Ibiam Federal Polytechnic, Unwana, Ebonyi State, Nigeria, where the mechanical sieve shaker was fabricated, coupled and assembled. The fabrication process undertaken involved measurement and cutting, drilling, welding, electrical connection and finishing.

2.3.1 Cutting and drilling operations

With the use of appropriate tools and equipment, the materials were measured and cut to required standard sizes using basic tools such as measuring tape, disc cutter, hacksaw, etc. The drilling process was carried out on the cut materials using drilling machine to create holes in the required parts for easy joining and assembling. During the process, drilling/cutting fluid or oil was used for easy penetration. This fluid also helps to reduce the friction between the drilling bit and the material or work piece. The list of materials that underwent cutting and drilling processes are presented in Table 2.

Table 2. Cut and/or drilled parts and dimensions

Materials	Dimensions	Parts
Angle bar	290 – 441 mm (depending on the side occupied and size of the frame)	Frame
Mild steel.	50 mm	Stand
Mild steel flat bar.	40 mm	Collector holder
Transparent polyester sheet.	386 x 335 mm	Sieving housing
Mild steel rod.	300 mm	Sieve clamp
Mild steel sheet.	310 x 441 mm	Electric motor casing or lower compartment.
High speed spring	53 mm	Electric motor casing or lower compartment.
Collector basement or carriage.	Ø300 mm	Sieve vibrator or shaker.

2.3.2 Welding and assembling

Welding was the joining process utilized in the fabrication of the mechanical sieve shaker. The materials were welded together to form a frame. The welding of the frame joints was done intermittently to ensure the firmness of the welded materials. In order to improve the optimal performance and minimise or eliminate residual stress introduced into the welded frame for the mechanical sieve shaker, post-weld treatment is required. Residual stresses are stresses introduced in a material during processing, e.g., welding. They originate as a result of cold working or differential thermal expansion or contraction[12]. One of the ways the hazardous residual stresses are eliminated is by introducing compressive stress at the surface of the material or body by shot peening [12]. In this work, hammer peening (type of shot peening) was employed. Hammer peening involves striking the metal surface (including the welded joints) by a round or spherical shot containing metallic, glass or ceramic particles with enough force to generate compressive stress. This post weld treatment reduces stress corrosion or strength fatigue, etc. [13]. The sieve housing was formed with the use of an angle bar while the transparent polyester material was fixed to it. The shaft was affixed to the base of the shaker and was then made to pass through the bearing placed in the bearing housing. The shaft was bolted to the base of the shaker.

The electric motor base, the polyester material and the stack base were placed in the frame. The polyester material apart from being part of the support base, serves as a damping material. Damping material reduces or eliminates vibration transmission (mechanical or electrical), movement or noise by converting these variables into heat or thermal energy[14]. The casing made of mild steel was then welded to the frame which serves as housing to the electric motor and the shaft. The electric motor was then placed and bolted to the frame of the housing. All other components were bolted tightly to the frame. A pulley was affixed and tightened to the upper part of the shaft end and then connected to the motor using the belt.

2.3.3 Electrical Connections

The electrical part of the constructed mechanical sieve shaker was coupled using the following materials:

1. Electric motor: 220 V, 2.5 A, 0.3 KW, 1400 rev/min and 0.8cos Ø
2. Capacitor (with specifications: 12 µf ±5%, 350 V, 50/60 Hz)
3. Variable dimmer switch, regulator and fuse
4. Connector and connecting wires
5. Soldering lead wire and flux

These electrical components were soldered on the control/switch board using a soldering iron, lead wire and flux. The electrical connection was performed using the circular current flow principle which allows electric current to flow through a direction. The variable dimmer switch controls the ON and OFF of the circuit as well as the speed of the electric motor. The fuse was connected to serve as a surge guide against unsafe voltage and current flow into the circuit. All the physical connections were carried out in accordance with International Electrical and Electronic (IEE) Regulation. At the end, the mechanical sieve shaker and the power source were properly earthed.

2.3.4 Finishing

Finishing is the final operation which involved grinding, polishing and painting of the fabricated mechanical sieve shaker. Splash of molten metal slag deposited on the body of the fabricated shaker during welding was removed using filing machine while heavy weight filler was used to body- fill the rough surfaces. Afterwards, debris and rust on the metal surface were removed and smoothed using emery paper of different grits. The smoothed body surface of the shaker was washed with water, allowed to dry and finally painted with a chromium oil paint mixed with thinner using a spraying gun. A schematic of the locally fabricated mechanical sieve shaker is shown in Figure 3.

2.4 Costing of materials

The materials utilized, quantities and prices are presented in Table 3. The cost of the raw materials purchased and labour were put to sixty-five thousand, five hundred and fifty naira (N65, 650; 157.87 USD). A survey of the market price for imported mechanical sieve shaker of similar size and capacity to the fabricated one was an average of ninety-five thousand naira, N95,000 (228 USD).



Fig. 3. Schematic of the fabricated mechanical sieve shaker

Table 3. Research costing

S/N	Description	Quantity	Unit Price (₦)	Total amount(₦)
1	1x1 Angle bar	1	2,000	2,000
2	1mm Sheet metal	1/2	4,500	4,500
3	Polyester sheet	1/2	2,000	2,000
4	Electric motor	1	8,500	8,500
5	Dimmer switch	1	700	700
6	Power switch	1	250	250
7	Power cable	1	2,000	2,000
8	Capacitor	1	700	700
9	Set of standard sieves	4	14,000	14,000
10	Collector	1	4,000	4,000
11	19 Bolt and nut	4	50	200
12	12 Bolt and nut	5	40	200
13	Springs	4	250	1,000
14	3" Hinges	2	200	400
15	2" Hinges	2	200	400
16	Heavy weight filler	1/4	1,000	1,000
17	Emery paper	1	200	200
18	Chromium oil paint	1	1,000	1,000
19	Workmanship		20,000	20,000
20	Miscellaneous	...	3,000	3,000
21	Total cost			N65,650

3. TESTING OF THE FABRICATED MECHANICAL SIEVE SHAKER

After a successful fabrication of the mechanical sieve shaker, it was subjected to preliminary test via sieve analysis to ascertain its sieving efficiency, reliability, durability, repeatability and accuracy. A sample ceramic powder (500 g) was used for the test run. The powder was prepared via grinding using mortar and pestle, dried, sieved and the required values (weight/mass of sample retained or passing, percentage retained or passing, etc.) were determined using standard procedure[6]. The following procedure was used for the sample preparation and calculation of results:

1. The ceramic sample (powder) was oven dried for about 24 hours to eliminate moisture.
2. Approximately 500 g of the powder was accurately measured. Note that the sample should have more than 95 % passing the No.1 (A) sieve and less than 5 % passing the No.4 (D) sieve.
3. The sieves (RETSCH) were carefully brushed to ensure that all loose materials are removed.
4. Oven dry mass of the sample was obtained.
5. The weight of the sieves was obtained.
6. The sieves (four in number) were combined in a stack with the pan (collector) at the bottom.
7. The sieves were arranged in descending order with the widest aperture sieve at the top and the smallest aperture sieve at the bottom. A collector was fitted at the bottom, after the last sieve and a cover at the top.

8. The powder was poured into the top sieve and the lid was placed on the top sieve.
9. The sieves were placed on the shaker and the shaker was ran for about 10-15 minutes.
10. The sieves were removed from the shaker and the weight of each sieve with sample retained on it was carefully measured and then transferred into the pan.
11. The weight of sample retained on each sieve was obtained by subtracting the weight of the empty sieve from the mass of the sieve plus retained sample, and this mass was recorded as the weight retained. The sum of these retained masses should be approximately equal to the initial mass of the sample. A loss of more than two percent (2 %) is unsatisfactory.
12. The percent retained in each sieve was calculated by dividing the weight retained on each sieve by the original sample mass and multiplied by 100.
13. The percent passing (or percent finer) was calculated by starting with 100 % and subtracting the percent retained on each sieve as a cumulative procedure.

3.1 Results and Discussion

The obtained values were calculated and the results are summarized as shown in Table 4 while the grading curve is presented in Figure 4. The result of the test-run showed that the fabricated sieve shaker could perform efficiently with the optimum sieving efficiency of about 97 %. The results show that the machine cannot sieve effectively larger coarse particles such as gravel but can sieve effectively fine particle size of the order of 0.1 to 1.0 mm.

Table 4. Results of the test run

Sieve size (mm)	Retained (g)	Percentage retained (%)	Cumulative percentage	
			Retained	Passing
> 5	0	0	0	100
5	25.5	5.10	5.10	94.90
1.7	47.5	9.50	14.60	85.40
1.18	128.25	25.65	40.25	59.75
0.71	155.61	31.12	71.37	28.63
< 0.71	140.77	28.15	100	0
	497.63			

The percentage of mass lost during the analysis is calculated using the following formula:

$$\% LDA = \frac{MSM - TMSR}{MSM} * 100$$

where, % LDA = % loss during analysis, MSM = mass of starting material = 500 g and TMSR = total mass of sample retained = 497.63 g.

$$\therefore \% LDA = \frac{500 - 497.63}{500} * 100 = 0.47 \%$$

Since the obtained loss is less than 2 %, it shows that the fabricated mechanical sieve shaker is efficient. The results of the sieve analysis also show that the bulk (71.4 %) of the sample aggregates fall between 5 - and 0.71-mm.

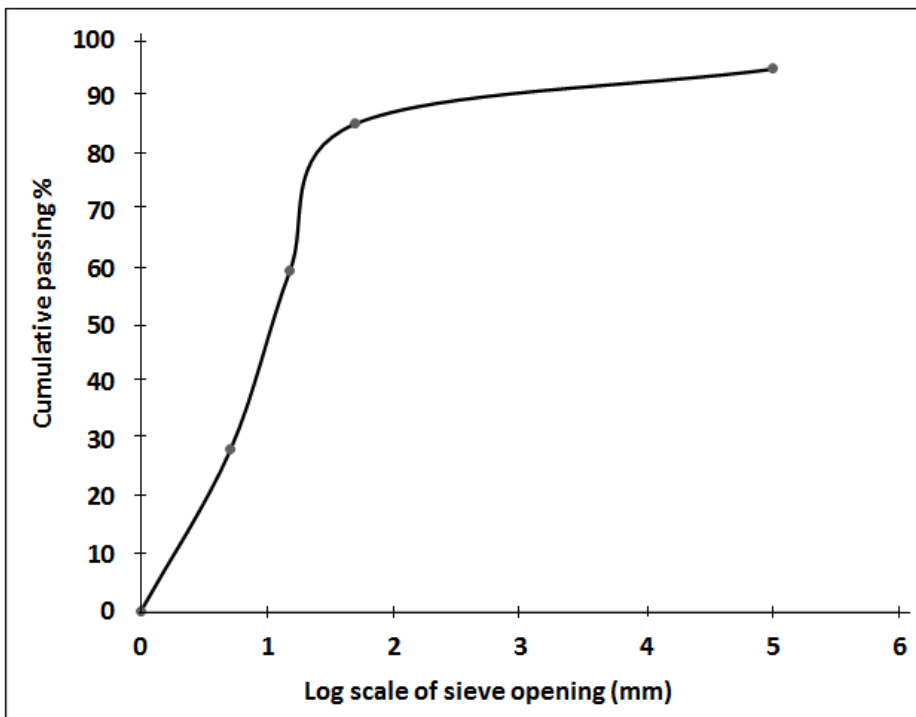

Fig. 4. Grading Curve.

4. Conclusions

A mechanical sieve shaker suitable for particle size analysis particularly sieving of ceramic powders for the purpose of processing the coarse particles into required fine particles was designed, fabricated and tested. The fabricated mechanical sieve shaker performed well with high sieving efficiency, reliability and durability.

The locally fabricated shaker is cost effective (~ ₱65,000) when compared to the imported ones (~ ₱95,000) in the market. When tested, it performed well with high sieving efficiency (97 %), reliability and durability.

REFERENCES

- [1] A. Jillavenkatesa, S. J. Dapkunas, and H. Lin-Sien, "Particle Size Characterization," *NIST Spec. Publ.*, pp. 960–961, 2001.
- [2] A. S. Instruments, "Particle Size Analysis," <https://www.atascientific.com.au/tag/particle-size-analysis/>,

2021.

- [3] K. Zhang *et al.*, "Particle size distribution measurement techniques and their relevance or irrelevance to sand control design," *SPE - Eur. Form. Damage Conf. Proceedings, EFDC*, vol. 1, no. March 2016, pp. 412–424, 2014, doi: 10.2118/168152-ms.
- [4] I. Malvern, "A Basic Guide to Particle Characterization. INFORM WHITE PAPER," *Malvern Instruments Ltd.*, pp. 1–26, 2012, [Online]. Available: [http://golik.co.il/Data/ABasicGuidtoParticleCharacterization\(2\)_1962085150.pdf](http://golik.co.il/Data/ABasicGuidtoParticleCharacterization(2)_1962085150.pdf).
- [5] A. Mohammed, A. B. Hassan, K. C. Bala, A. Nasir, O. Okegbile, and D. S. Jimmoh, "Fabrication and Performance Evaluation of a Pedal Driven Pulverizing and Sieving Machine for Dewatered Grated Cassava," *Am. J. Eng. Res.*, vol. 4, no. 2, pp. 146-152., 2015.
- [6] C. Eccles and E. . Ekwue, "A mechanical shaker for sieving dry soil samples," *West Indian J. Eng.*, vol. 30, pp. 13–23, 2008.
- [7] E. Ali, E. I. Ekwue, J. Bridge, and R. Birch, "A Three-Stack Mechanical Sieve Shaker for Determining Aggregate Size Distribution of Soils," *West Indian J. Eng.*, vol. 35, no. 2, pp. 36–44, 2013.
- [8] J. E. Bowles, *Engineering Properties of Soils and Their Measurement*. McGraw-Hill, 1992.
- [9] H. O. Tuffour, "Analysis of Hydraulic Resistance of Soil Surface Seals in Relation to Sediment Particle Size," *Int. J. Plant Soil Sci.*, vol. 15, no. 1, pp. 1–11, 2017.
- [10] R. K. Rajput, *Material Science in Engineering*. New Delhi: Kataria & Sons Publishing Co. Ltd, 2010.
- [11] E. O. Adebayo, "Corrosion Control of Petroleum Pipelines," University of Illorin, Illorin, Nigeria, 2014.
- [12] D. R. Askeland, P. P. Fulay, and D. K. Bhattcharya, *Essentials of Materials Science and Engineering*. Stamford, USA: Cengage Learning, 2010.
- [13] P. Young, "What is peening," www.weldingheadquarters.com. Accessed May, 2022.
- [14] Sorbothane, "Innovative shock and vibration solutions," www.sorbothane.com. Accessed Febr., 2022.