

# Study Protocol

## **Investigating the structure and operation of a normal transistor (BJT)**

**Abstract.** A transistor is an electronic component that amplifies signals or acts as a switch in a circuit. Transistors enable us to control, divert or even reverse the amount of current flowing through a circuit. When we talk about amplifying signals, we're talking about the amount of power (voltage x current) that flows through the circuit. Transistors are used in the complex switching circuits that make up all modern telecommunications systems. A transistor can act as a switch or gate for electronic signals, opening and closing an electronic gate several times per second. Transistors are used as switches, amplifiers, voltage stabilizers, etc. in electronic circuits. A typical transistor consists of **three n-type and p-type semiconductor crystals** placed side by side. The abbreviations PNP and NPN and technical symbols are used to represent transistors on drawings. The arrangement of transistors in electronic circuits is common emitter, common base and common collector. In this article, while dealing with the general characteristics of transistors such as transistor construction, bias, load line, calculations related to bias and its applications in simple amplifiers, we also discuss how each one works. Before the invention of the transistor in the first half of the 20th century, electronics depended on vacuum tubes, which were bulky, expensive, and uneven, required a lot of power, and produced a lot of heat. The invention of transistors led to modern electronics, making smaller and more powerful electronic devices possible because transistors require little power, don't generate much heat, and are very reliable. Small transistors can be used in complex integrated circuits, making it possible to pack a lot of computing power into a small package.

**Key words:** P-N junctions, BJT transistor, PNP and NPN types.

### **Introduction**

Before the invention of the transistor in the first half of the 20th century, electronics depended on vacuum tubes, which were bulky, expensive, and uneven, required a lot of power, and produced a lot of heat. The invention of transistors led to modern electronics, making smaller and more powerful electronic devices possible because transistors require little power, don't generate much heat, and are very reliable. **A typical transistor consists of three P-type and N-type semiconductor pieces.** Small transistors can be used in complex integrated circuits, making it possible to pack a lot of computing power into a small package. There are two main types of transistors: bipolar junction transistors (BJTs) and field effect transistors (FETs) **[5], [6]**. The construction of bipolar transistors and their structure has come a long way since the first transistors were made. Today's transistors are manufactured using complex processes, and the transistor structure enables them to have very high performance. The modern era of semiconductor electronics began with the invention of the bipolar transistor in 1947 by John Bardeen, Walter Brattin and William Shockley **[1],[3]**. This piece, along with its field counterpart, has had a surprising impact on almost every aspect of modern life. A BJT transistor uses electrons and electron deficiencies (as electron holes) to carry charge. When an electron leaves its current state for a higher electron,

holes are left in the conducting material. These holes can move like electrons in matter and behave like positively charged particles [3],[5]. When a small current is applied to one of the BJT's terminals, it effectively allows the transistor to control much more current between the emitter and the collector, which in turn allows the current to be amplified or changed. In this tutorial, we will focus only on the bipolar junction transistor and discuss its basic structure and operation. **A typical transistor (BJT) is made up of three P-type semiconductors.** The arrangement of semiconductor crystals is shown in figure1[8,9].

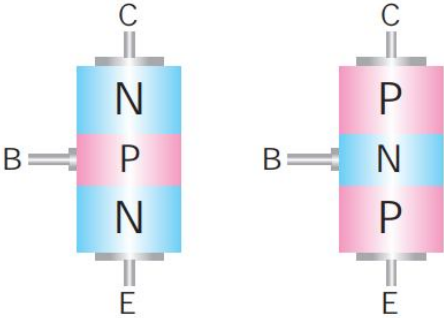

Figure 1. How N and P type semiconductors are placed in the transistor

**Bipolar Junction Transistor (BJT)**

A typical transistor consists of three P and N type semiconductor pieces. The difference between PNP and NPN BJT is in the bias, which is the direction of current allowed to flow. In a PNP BJT, there are two positively charged regions - the collector and the emitter - each with additional holes. The depletion region in between the two is negatively charged because it has extra electrons. Boundaries between regions are called links. The base-emitter junction is reverse biased and the base junction is collected is forward A small voltage is applied to the base region. In an NPN BJT, there are two negatively charged regions - the collector and the region Emitter - each with extra electrons. The discharge region is positively charged because it has extra holes. In an NPN BJT, the base-emitter junction is forward-biased and the base-collector junction is reverse-biased. A small voltage is applied to the base Region [2], [6]. The transistor which is made of two P-type semiconductor pieces and one N-type semiconductor piece is called PNP transistor and the transistor which includes two P-type semiconductor pieces and one P-type semiconductor piece is called NPN transistor. Figure2 shows two types of NPN and PNP transistors and their symbols [7],[9].

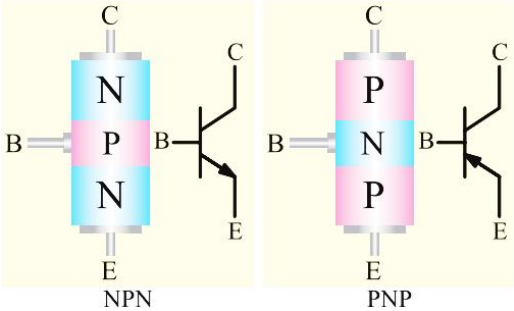

Figure2. Conventional symbols of PNP and NPN transistors

The bases of the transistor are called emitter (E), base (B) and collector C. Figure 4 shows the names of transistor bases[3,6].

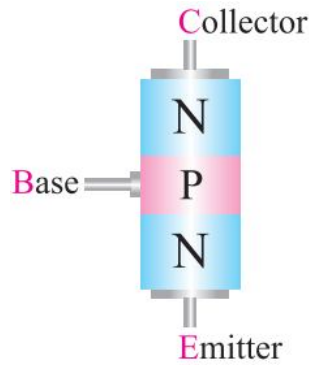

Figure.3 Names of transistor bases

### Equivalent to PNP and NPN transistor diodes

Each P-N connection is equivalent to a diode, so the diode equivalent of NPN and PNP transistors is drawn in Figure. [8].

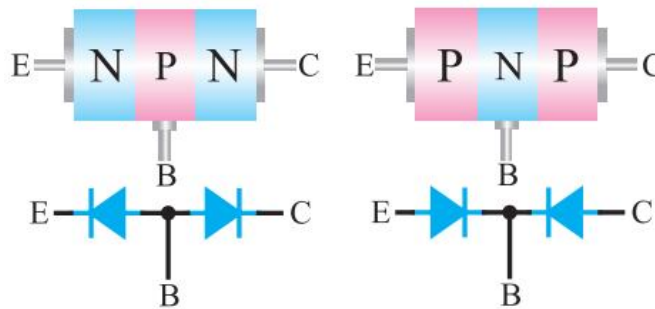

Figure.4Equivalent of NPN and PNP diode transistors

### How to bias the transistor in the active region

In the active region, it is necessary to place the base-emitter diode in the positive bias and the base-collector diode in the opposite bias so that currents are established in the transistor. Figure 5 shows how to bias an NPN transistor in the active region [2-6].

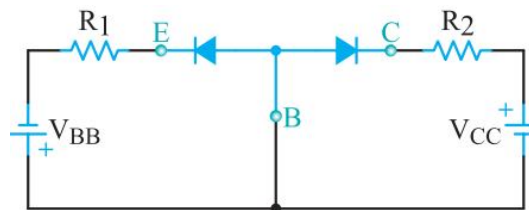

Figure.5 NPN transistor bias in the active region

## BJTs under Varying Voltages

A transistor's functions depends on the voltages applied and the polarity of the current. The following formulas show the function of the transistor in various scenarios. The subscripts refer to the base ( $V_B$ ), the collector ( $V_C$ ), and the emitter ( $V_E$ ).

- If  $V_E < V_B < V_C$ , then the transistor acts as an amplifier.
- If  $V_E < V_B > V_C$ , then the transistor is a conductor.
- If  $V_C > V_B < V_E$ , then the transistor is an open switch and cuts off the flow.

Think of positive voltages as being greater than zero, or  $+V > 0$ , and negative voltages as being less than zero, or  $-V < 0$ . This will make working through these formulas easier [6].

## Power BJTs

The n-p-n bipolar junction transistor, BJT in short, is shown in Figure6. The collector (C) to emitter (E) path serves as the switch, conducting or interrupting the main current, while the base (B) is the control electrode. In contrast to thermistors, the collector current,  $I_C$ , can be continuously controlled by the base current,  $I_B$ , as

$$I_C = \beta I_B$$

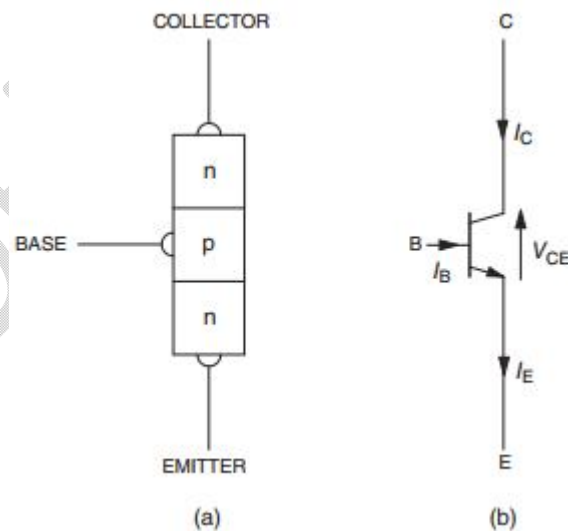

**Figure.6**BJT: (a) semiconductor structure, (b) circuit symbol.

Where  $\beta$  denotes a dc current gain of the transistor. In high-power *BJT*s, the current gain is low, on the order of 10. The emitter current,  $I_E$ , is a sum of the collector and base currents. The voltage-current characteristics of the *BJT*, specifically the collector current,  $I_C$ , versus collector-

emitter voltage,  $V_{CE}$ , relations for various values of the base current,  $I_B$ , are shown in Figure 7. The conduction power loss,  $P_c$ , is given by [3,6,8].

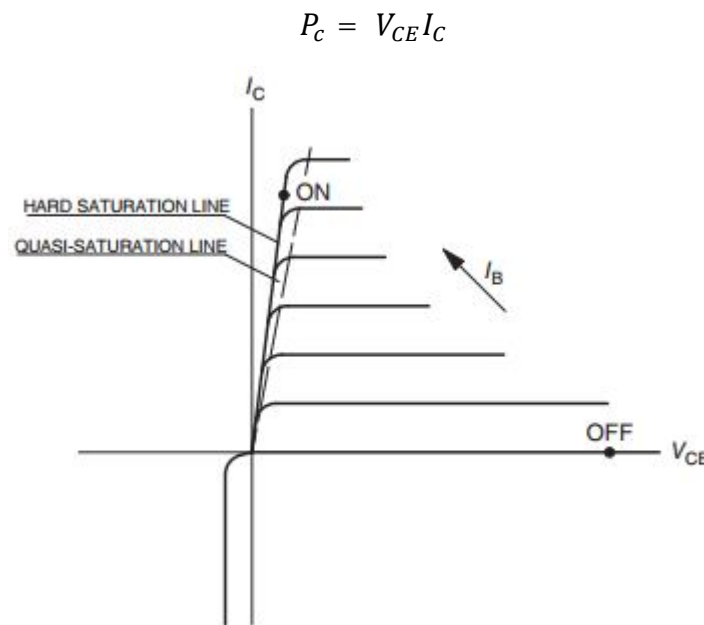

Figure .7Voltage–current characteristics of the BJT

## Conclusion

The results of the findings show that bipolar transistors are composed of P-N-P or N-P-N semiconductor "sandwich" structure. The three wires of a bipolar transistor are called emitter, base and collector. Transistors act as current regulators, allowing a small current to control a larger current. The amount of current allowed between the collector and the emitter is primarily determined by the amount of current that flows between the base and the emitter. For a transistor to function properly as a current regulator, the controlling (base) and controlled (collector) currents must flow in the correct directions: additively in the gridded emitter and in the direction of the emitter arrow symbol. In bipolar junction transistors, both minority carriers and majority carriers are involved in current generation. In a bipolar junction transistor, the collector current can be controlled by the base or emitter current. For the transistor, depending on whether the connections of the collector base and the emitter base are direct or inverted, three working areas are considered. The performance of the transistor depends on the applied voltage and the polarity of the current.

## References

1. Dastgeer, G., Shahzad, Z. M., Chae, H., Kim, Y. H., Ko, B. M., &Eom, J. (2022). Bipolar junction transistor exhibiting excellent output characteristics with a prompt response against the selective protein. *Advanced Functional Materials*, 32(38), 2204781.
2. Ahn, S. H., Sun, G. M., &Baek, H. (2022). Turn-off time improvement by fast neutron irradiation on pnp Si Bipolar Junction Transistor. *Nuclear Engineering and Technology*, 54(2), 501-506.
3. Attia, J. O. (2017). *Circuits and Electronics: Hands-on Learning with Analog Discovery*. CRC Press.
4. Shokri, A., &Amirmazlaghani, M. (2023). Feasibility of Digital Circuit Design based on Nanoscale Field-Effect Bipolar Junction Transistor. *Journal of Electrical and Computer Engineering Innovations (JECEI)*, 11(1), 33-40.
5. Xie, S. (2022). BJT induced dark current in CMOS image sensors. *Integration*, 87, 260-263.
6. Westcott, S., & Westcott, J. R. (2020). *Basic Electronics: Theory and Practice*. Mercury Learning and Information.
7. Suits, B. H. (2020). *Electronics for Physicists: An Introduction*. Springer Nature.
8. Santos, L. A. (2022). An overview on bipolar junction transistor as a sensor for X-ray beams used in medical diagnosis. *Sensors*, 22(5), 1923.
9. Liu, C., Li, X., Geng, H., Rui, E., Yang, J., & Xiao, L. (2012). DLTS studies of bias dependence of defects in silicon NPN bipolar junction transistor irradiated by heavy ions. *Nuclear Instruments and Methods in Physics Research Section A: Accelerators, Spectrometers, Detectors and Associated Equipment*, 688, 7-1