

# A Finite-Element Method of Solution for Frame of Tractor Operated Single Row Maize Cobs Picker

## ABSTRACT

Finite element analysis (FEA) is a computational technique that divides complex structures into small elements and solves them numerically using various partial differential equations. In agriculture, engineers can use numerical simulation based on the FEA technique to study the behaviour of various input products in order to optimise the design of any machine without developing a prototype. The present study focused to design and simulates the frame of tractor operated single row maize cobs picker by employing the FEA technique. A 3D-CAD model of the frame of a tractor-operated single row maize cobs picker was created using the Solid Works software, and a static structural test was performed using the FEA technique in the ANSYS version 15.0 workbench software. A special fixture has been developed to calculate the force required to scrape the pulpy material of the leaves in the Universal Testing Machine. The simulated results predicted that maximum deformation was observed as  $8.09e^{-7}$  m while maximum shear stress and VonMises equivalent stress were found to be  $1.30e^5$  Pa and  $2.48e^5$  Pa, respectively at 250 N scraping forces. It was also observed that stress values are within the yield strength of the material. The FEA approach was found to be a scientific and highly effective method for designing and simulating the frame of a tractor-operated single row maize cobs picker.

**Key Words:** ANSYS, Total deformation, VonMises equivalent stress and FEA.

## 1. INTRODUCTION

Maize or corn is the third most important cereal crop after rice and wheat for India. Globally it is highly valued for its multifarious use as food, feed, fodder, and raw material for a large number of industrial products. Among the maize growing countries India rank 4th in the area and 7th in production, representing about 4% of maize area and 2% of the total production of the world. During 2018-19, in India, the maize area has reached up to 9.2 million ha (Anonymous, 2020).

In usual practice, maize harvesting is done manually, and ears are collected in burlap bags. This method does not require any specific tool but involves high labour requirement. Labour is provided by women and children, who are not normally involved in ridging. In fact, traditional maize harvesting is time consuming from 25-30 days per hectare (FAO, 1994) and it is done in a bending posture. Furthermore, maize harvesting period affects both its quality and harvesting efficiency (Gaile Z, 2008). As it has been argued by (Kim TH, 2000), if harvesting is delayed because of climate or hybrid maturity, maize yield and quality may decrease due to microbial infection or frost damage. These difficulties involve low harvesting capacity, crop quality, financial return and high labour requirements.

Cultivation of maize can only be made profitable if the share of human and animated power towards monetary farm inputs is to be mitigated which is only possible by the adoption of suitable farm mechanization techniques in maize cultivation (Varghese, 2006). Recommended picking the cobs from the plant is done when the matured cob has moisture is about 25-40%. Between harvesting and picking time there is a gap of 6-8 weeks which reflect the long exposure of the plants to the sun completely dry and loss the nutrient, it requires more energy. If plants are chopped directly from the plant, then plants are proper moisture and it is optimum for making silage for getting the get quality fodder. In a crop production system, high labour demands in operation cannot or have not been mechanized. In the operation of picking the cobs and harvesting maize plants, labour peaks have to be mechanized to have a high return. So frame is made for maize picker are imported because all machine components are supported by the frame. Frame are durable, cheap and strengthful.

Finite Element Analysis (FEA) or Finite Element Method (FEM) is a numerical technique that divides complex structures into a number of small elements and approximates solutions to algebraic equation boundary value problems (Zienkiewicz et al, 2013). The exact origin of FEA cannot be predicted, but it is gaining popularity due to advances in computer technology. This technique works on the principle of formulating and solving the problem's hypothetical equations, distinguishing the domain area of the

problem, and computing the variables of interest (Velloso et al, 2018). Engineers or developers can use FEA to investigate the behaviour of various input materials before developing mechanical prototypes, assisting both in the manufacturing process and in monitoring and detecting feasibility possible usage or material failures. To design and simulate any mechanical component of the entire body, software such as AutoCAD, CREO, ANSYS, SolidWorks, CATIA, and others are available on the market. These have various functions that are used for specific purposes by specific fields. ANSYS is the most powerful and widely used software among engineers for performing finite element analysis and obtaining numerical solutions to a wide range of mechanical problems. These problems include static/dynamic, structural analysis, heat transfer, and fluid problems, as well as acoustic and electromagnetic problems.

Although the finite element method is widely used in mechanical design, it is still in its early stages in agricultural machinery design. In addition, the literature on FEM was reviewed in the context of a tractor-operated single row maize cob picker. The goal of this study was to create a 3D model of the frame of a tractor-operated single row maize cobs picker and simulate it using the FEA technique to determine the suitability of the design for development.

## 2. MATERIALS AND METHODS

Frame of tractor operated single row maize cobs picker was designed and simulated by employing the Creo Parametric (version 7.0) and ANSYS workbench (version 15.0) software and fabricated at JNKVV, Jabalpur. These components were fabricated using the mild steel (MS) because of its various physical and mechanical properties suited for design, cheap, and readily available everywhere.

### Pipe frame

The pipe frame's basic structure was made of 50 mm CI pipe for mounting various components of the corn picking mechanism such as snapping rollers, gathering chain, sprockets, and so on. Three pairs of CI pipes, each with a length of 6000 mm, a width of 75 mm, and a thickness of 10 mm, were cut and welded repeatedly to shape the pipe frame, allowing the developed corn picking mechanism to be installed within it, as shown in Fig



**Fig.1: Solid Works design of frame**

### 2.2 Procedure of ANSYS analysis on the frame

The overall analysis is divided into some steps as follows:

1. In the ANSYS software for analysis of any part, there are three procedures followed, pre-procedure, procedure and post procedure.
2. Firstly, designing the 2D and 3D CAD models by using the solid works software.
3. In pre-procedure the force, boundary condition, and fix point are considered, after this, the mesh generation process starts. After the meshing operation, we know the total number of elements and a total number of nodes.
4. After that, the static analysis is used to determine the displacement, stress conducted and strain forces in the structure of the frame.

5. All the parameters are checked whether they are within permissible limits or not for selected materials.
6. Then the final result is concluded.

Fig 3 shown the Flow diagram of a procedure of ANSYS software and Table 1 shown the physical properties of the materials

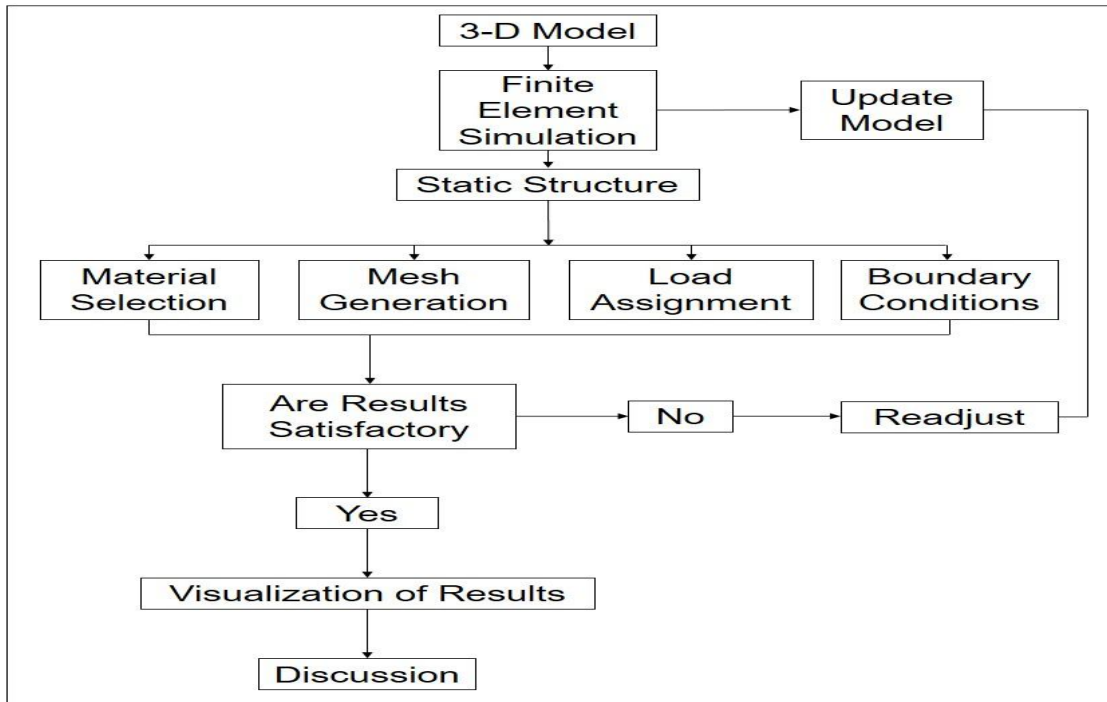

**Fig.2: Flow diagram of a procedure of ANSYS software**

**Table 1 Physical properties of the material**

MS STEEL	
Physical properties	Details
Modulus of elasticity (E), GPa	208
Density, kg/m <sup>3</sup>	7800
Tensile strength, MPa	350
Yield strength, MPa	175
Poisson's ratio	0.29

### Finite Element Analysis of the frame of tractor operated single row maize cobs picker

After launching ANSYS Workbench, the main user interface displays a wide range of analytical systems. The Static Structural Analysis (SSA) tool was chosen because the primary goal of this study was to examine the structural stress analysis of the frame of a tractor-operated single row maize cobs picker. The material used to build the frame is MS, and the properties of MS are not available in the existing library. As a result, a new material library with isotropic elasticity and density options is required. Table 1 shows the properties of the MS used in the analysis. The geometry for this previously developed CAD model was imported using design modeller, which is a parametric geometry modeller, as the next important step in FEM. The main advantage of design modeller is the ease with which existing geometry can be manipulated. Following that, meshing was completed in order to perform an accurate simulation using FEA. A mesh was created by combining the elements, which contain the various nodes (coordinate locations in space that vary depending on element type) that represent the geometry's shape. The default meshing method was chosen. The model's boundary conditions must be carefully applied to the model in the analysis setting. Wheels support the frame, and the load applied to the frame is approximately 1656

N. Static structural simulation was performed after applying the boundary conditions for selected parameters such as total deformation, equivalent stress, principal stress, and shear stress.

### 3. RESULTS AND DISCUSSION

#### Total deformation

The total deformation of the model indicates the area with the greatest force and bends. It also includes the amount of reaction force needed to bend a material. It is also used to calculate displacement from applied stress. The total deformation of the model is given by summing the squares of all the directional axes, namely x, y, and z. The colours red and blue represent maximum (0.051mm) and minimum (0 mm) deformation, respectively (Fig. 3). The results showed that the most deformation occurred in the centre, where the leaves were beaten and scraped. The analysis revealed that the centre of the frame model has the greatest deformation. The mild steel frame model has less deformation than the material's yield point (Khurmi and Gupta, 2005).

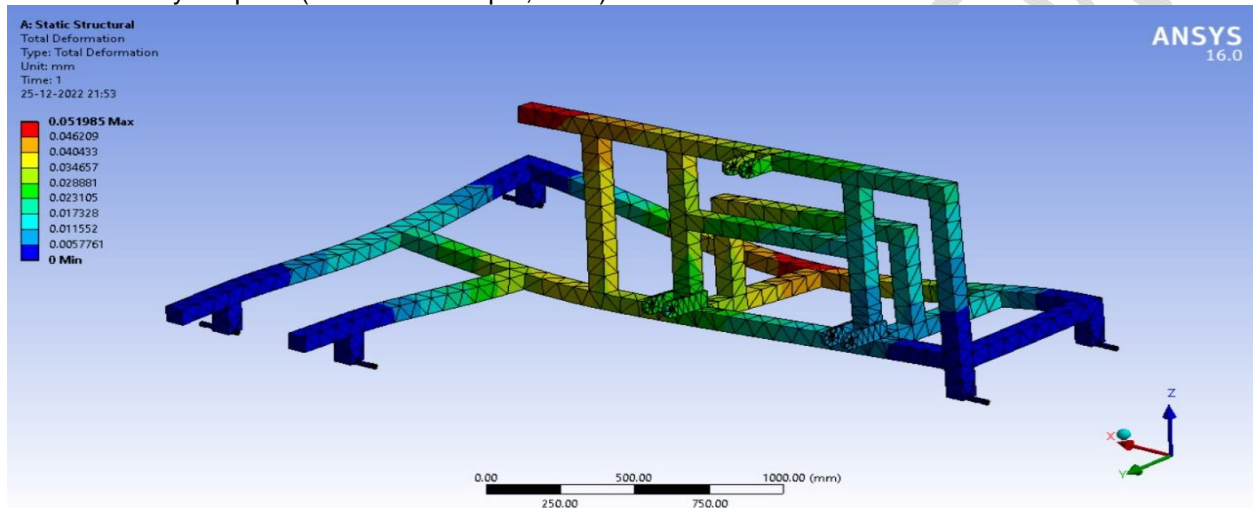

**Fig. 3: Total deformation on frame  
Maximum Shear Stress**

Material breakdown is determined by the product's maximum shear stress. The model's colour chart shows the maximum and minimum shear stress. The maximum shear stress measured was 0.246 MPa, while the minimum was -0.191 MPa (Fig. 4). The maximum shear stress of the model is less than its shear stress (200-300 MPa) (Khurmi and Gupta, 2005), indicating that deformation does not cause significant frame failure.

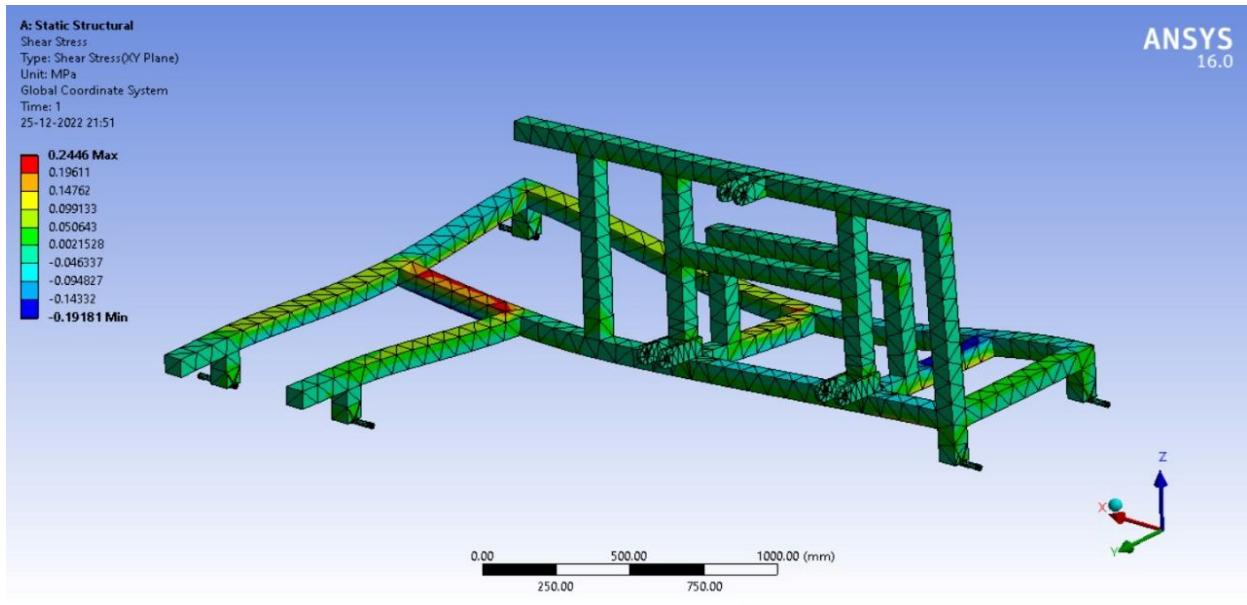

**Fig.4: Maximum shear stress on the frame**  
**Equivalent stress (Von Mises)**

As shown in Fig. 5, equivalent stress is computed to estimate yield failure criteria in ductile materials. The maximum equivalent stress measured was 1.47 MPa, while the minimum was  $1.46 \times 10^{-7}$  MPa. Jakasania et al. (2016) conducted a similar study and proposed that, when designing a model, working stress should be less than the maximum or ultimate stress at which material failure occurs.

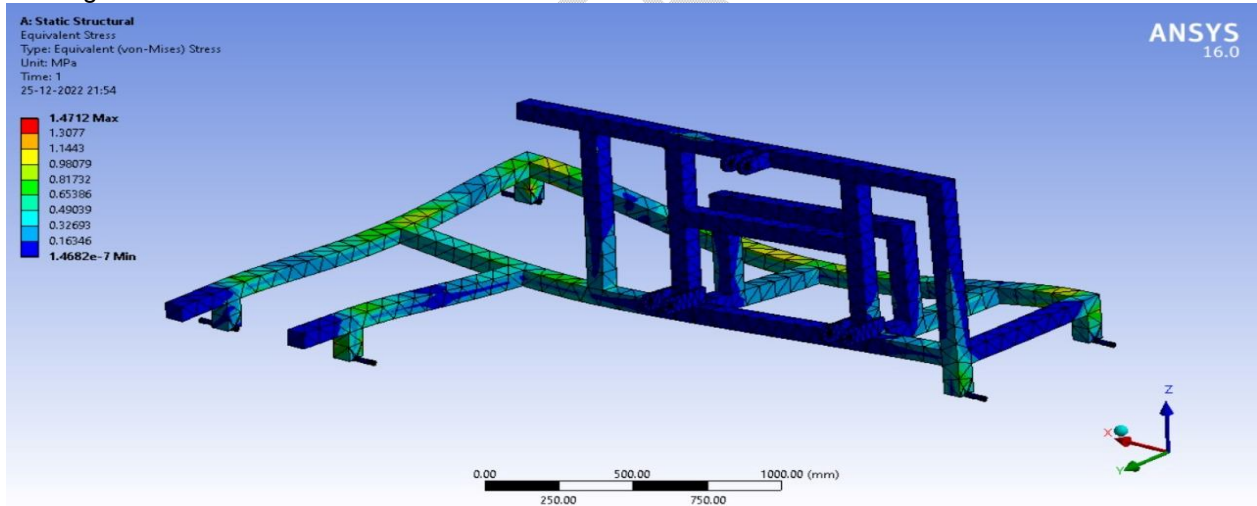

**Fig. 5: Equivalent von-mises stress on the frame**  
**4. CONCLUSION**

A 3D CAD model was created in the SolidWorks Parametric design software to design and simulate the frame of a tractor-operated single row maize cobs picker, and static structural analysis was performed in the ANSYS version 15.0 workbench software. A special fixture has been developed to calculate the force required to scrape the pulpy material of the leaves in the Universal Testing Machine. At 1650 N scraping force, the simulated results predicted that maximum deformation would be 0.051mm, while maximum shear stress and VonMises equivalent stress would be 0.246 MPa and 1.47 MPa, respectively. It was also discovered that the stress values are within the material's yield strength. As a result, the FEA technique was discovered to be a scientific and very effective approach to designing and the frame of a tractor operated single row maize cobs picker, and a prototype of the frame of a tractor operated single row maize cobs picker can be developed on the basis of that.

## REFERENCES

Anonymous. 2020. <http://www.indiastat.com>

Gaile Z. (2008b) Harvest Time Effect on Yield and Quality of Maize (*Zea mays* L.) Grown for Silage. Latvian Journal of Agronomy, 10, pp. 104-111.

Jakasania R G, Vadher A L and Yadav R (2016). Structural analysis of parabolic type subsoiler using CAD software. Int J of Sci, Environ and Technol 5 (5):3415-3422.

Khurmi R S and Gupta J K (2005). A textbook of machine design. Eurasia publishing house. Ram nagar, New Dehli

Meena B.S, Shrivastava A.K and Dubey R.K. (2020). Development and Evaluation of Manual Operated Two Row Planter for Onion Seeds, Current Journal of Applied Science and Technology, 39(48): 153-161

Nagesh Kumar T, Prateek Shrivastava, Manisha Jagadale, Shambhu V B and Nayak L K (2022). FEA Technique for Design and Simulation of Sisal Decorticator Raspador. J Krishi Vigyan 10 (2): 173-178.

Varghese, K.A. 2006. Studies on inputs for agricultural economic policy and development. Estimates of cost of cultivation of major crops in Rajasthan, DOR, MPUAT, Udaipur.

Velloso N S, Costa A L G, Magalhães R R, Santos F L and Andrade A T D (2018). The Finite Element Method Applied to Agricultural Engineering: A Review. Current Agric Res J 6 (3): 286-299.

Zienkiewicz O C, Taylor R L and Zhu J Z (2013). The Finite Element Method: Its Basis and Fundamentals. Hardcover ISBN: 9781856176330. EBook ISBN: 9780080951355.