

Assessment of Various Uniformity Aspects Under Surface Drip Irrigation System in Tomato

ABSTRACT

Background: Water in any form is the prime constitute of plant growth and development. Right amount of water applied at right time and in right quantity to any crop will help to get maximum yield potential of that crop. This is possible with surface drip irrigation method. Uniform application of water through emitters is the necessary aspect to avail benefits like higher water use efficiency of surface drip irrigation. Uniformity of surface drip irrigation system can be measured by various uniformity aspects viz., coefficient of variation (CV), distribution uniformity (DU), statistical uniformity (SU) and coefficient of uniformity (CU). Factors like land levelling, maintenance of drip lines, pressure management etc. plays a vital role in conserving the uniformity of outflow of emitters.

Methodology: In this trial, all these uniformity aspects were measured using catch can method at initial stage of drip irrigation system installation and on the basis of these dataset several improvements were made for better uniformity of emitter outflow at later planting stage.

Results: Coefficient of uniformity (CU) of surface drip irrigation system was recorded 96.89 % at initial stage and later on it was improved to 97.02 % during the first experimental year whereas in second year it was noted 95.58 % at initial stage and was improved to 96.80 % at later stage.

Keywords: coefficient of uniformity, coefficient of variation, distribution uniformity, statistical uniformity, surface drip irrigation, micro irrigation system (MIS)

1. INTRODUCTION

Indian agriculture has significant 19.90% share in country's GDP which support the fact that 70% populace of country is directly depends on farming for their livelihood [1]. Horticulture especially vegetable crops tribute vital contribution in this agricultural GDP which makes it more reliable crop. Vegetables are good source of vitamins, minerals and other beneficiary elements which makes it protective food for mankind and considering this fact Indian council of medical research (ICMR) have recommended a daily uptake of 300 g vegetables/day including 125 g green leafy vegetables, 100 g root vegetables and 75 g other vegetables [2]. Contribution of agriculture towards Indian GDP can be increase with right selection of crop and applying accurate amount of irrigation water.

Water is a crucial component and deciding factor for successful cultivation of any vegetable crop. Adequate quantity with precise application method is a key factor for judicious application of water which leads to higher water productivity. Agriculture will face complex challenges by the year 2050 to satisfy an estimated population of around 10 billion. To feed this population, more water will be needed to produce the estimated 60% of extra food [3]. Moreover, water is becoming scarcer day by day and less than 1% of total 2.75% available fresh water on Earth is potentially available to the plants. Agricultural sector has been the largest consumer of freshwater for and accounts for about two-thirds of total fresh water. More emphasis needs to be given to fulfill the requirements of irrigated agriculture as it doubles crop yield in comparison to rain-fed agriculture. Use of surface drip irrigation system instead of traditional less efficient methods of water application can effectively improve water use efficiency and water productivity [4].

Surface drip irrigation is defined as application of water on the surface of soil near the root zone of crop through emitters with uniform discharge rate [5]. Surface drip irrigation offers several advantages i.e., precise placement and efficient management of water, improved nutrient and water use efficiency, uniform application of water, reduced evaporation loss, reduced weed growth, better water productivity and many more [6] [7]. Benefits of surface drip irrigation system and uniformity of

application water are highly based on several factors like, system design considering land leveling, slope, laterals cleaning, pressure management, system maintenance etc. [8] [9].

The uniformity aspects of surface drip irrigation system can be quantified by various parameters viz., coefficient of variation (CV), distribution uniformity (DU), statistical uniformity (SU) and coefficient of uniformity (CU). Value of these parameters indicates the uniformity for particular setup of drip irrigation system and on the basis of these data one can maintain and improve the same. Uniform water delivery to crop is a critical element in preventing over watering, dry spots in soil, uneven wetting patterns, crop stress and lack of nutrient delivery. Reasons for low uniformity score in surface drip irrigation systems are poor maintenance, plugging, improper levelling of land and many more but with help of these data one can access the issue well in advance before crop sowing or planting. Higher values (> 90 %) of DU, SU and CU and lower value of CV (< 0.1 %) are desirable to get excellent uniformity in water distribution of surface drip irrigation system [10].

Considering these, present study was designed to assess various uniformity aspects in field of tomato under surface drip irrigation system during the tenure of two seasons. The main objective of the study was to measure various uniformity parameters at the initial stage (at time of drip irrigation system installation) and on the basis of these data correction were made in the aspects of various factor to improve uniformity of surface drip irrigation system at the later stage (at the time of planting).

2. MATERIAL AND METHODS

2.1 Experimental site

The trial was carried out at Regional Horticultural Research Station, ASPEE College of Horticulture and Forestry, Navsari Agricultural University, Navsari, Gujarat, India during *Rabi* (winter) season in two consecutive years 2021-2022. The soil of experimental site was known as black cotton soil, rich in organic matter, moderately drained with good water holding capacity. The experimental field was prepared by ploughing and harrowing. Land levelling was done with the help of wooden plank keeping a very gentle slope.

2.2 Drip irrigation system

The experimental area i.e. 898.70 m² (20.90 m × 43.00 m) comprised of twenty-four plots having one main and four submain lines. Area covered by individual plot of experiment was 28.35 m² (6.3 m × 4.5 m) having seven lateral lines with ten drippers on each lateral. Surface drip irrigation system was installed according to the standard guidelines. Lateral lines incorporated in the trial had specific features like, 16 mm diameter, 45 cm dripper spacing and 4 liter hour⁻¹ (lph) dripper discharge capacity. The experimental layout of field and plot along with MIS system arrangement were depicted in Figure 1 and Figure 2, respectively.

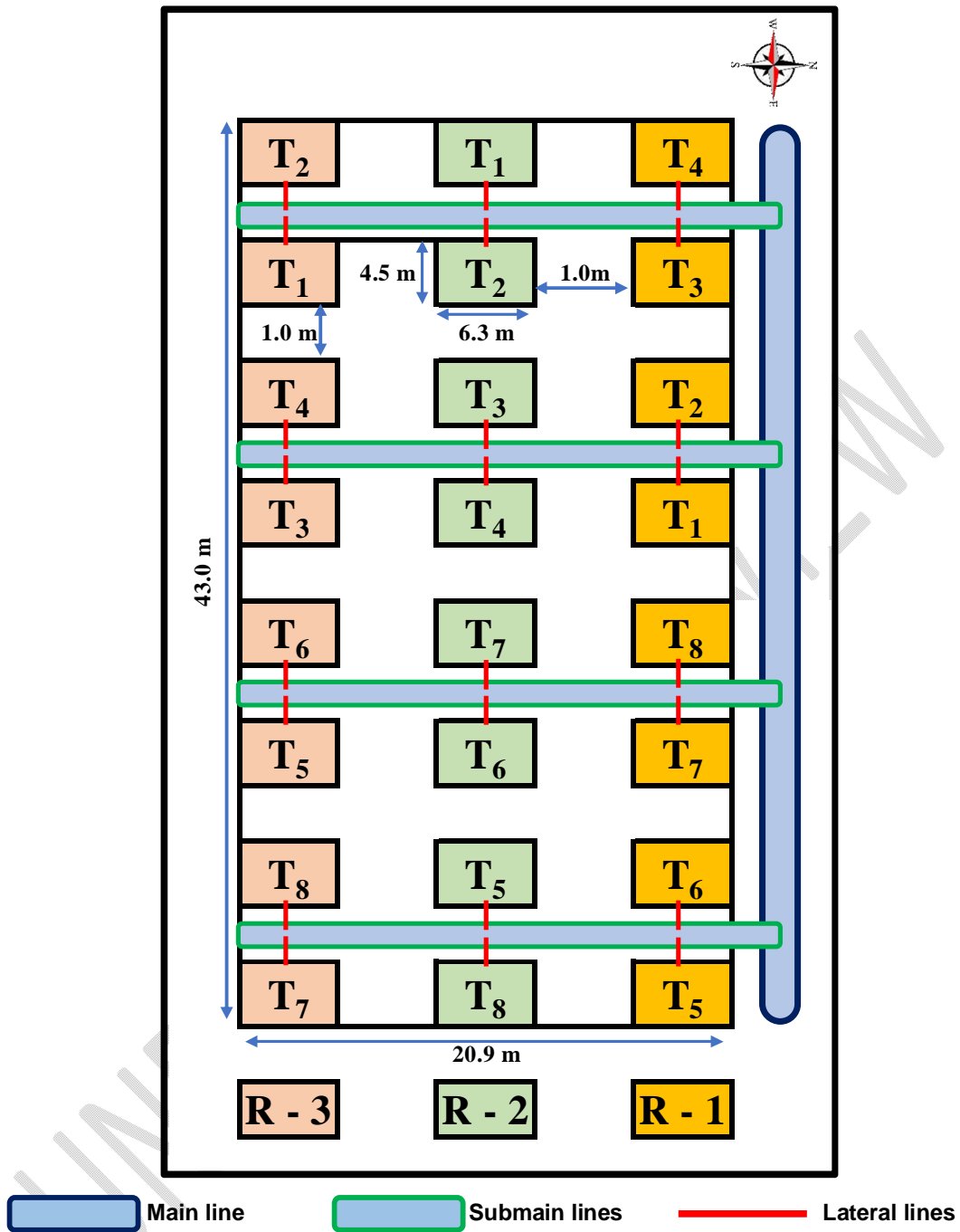

Figure 1. Whole field layout

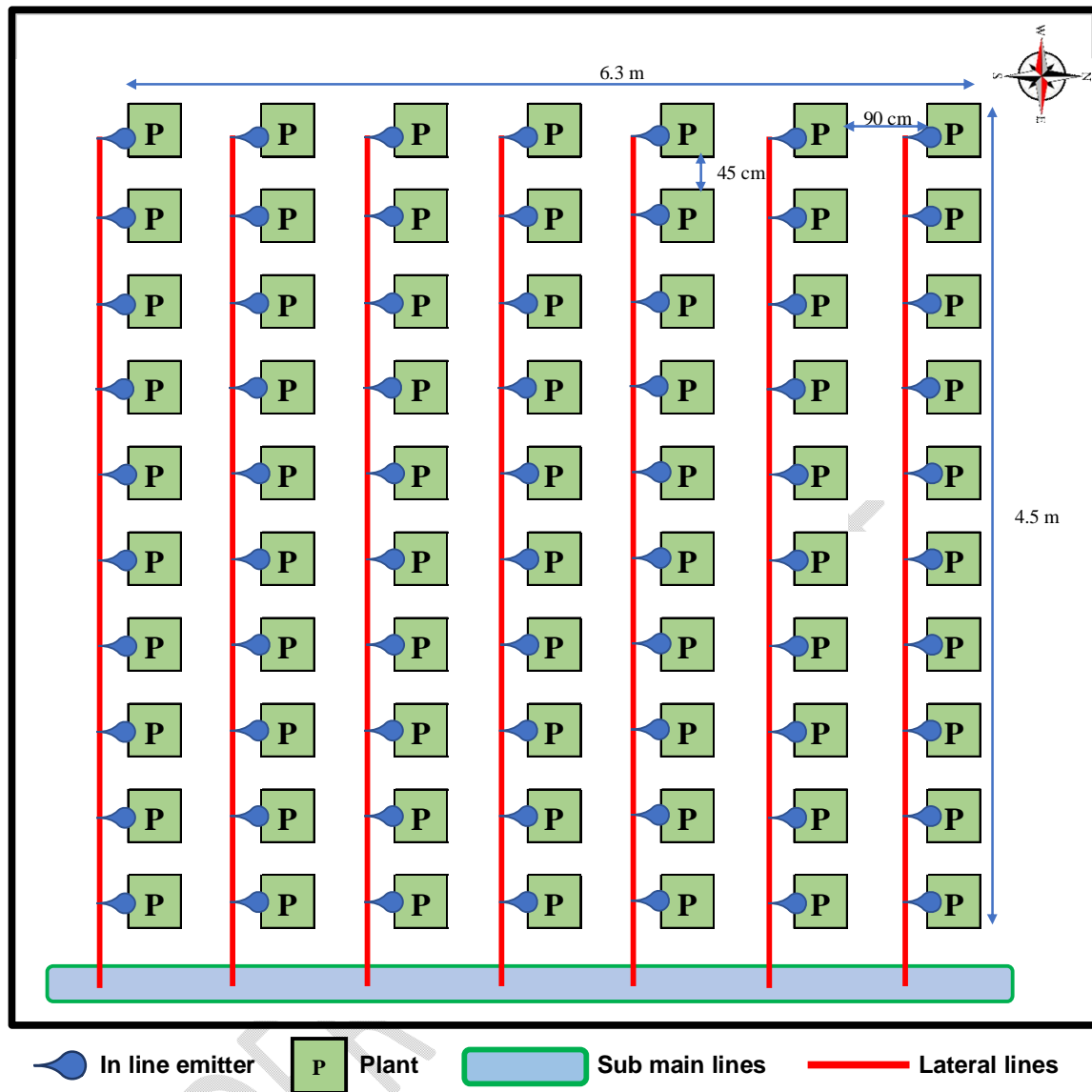

Figure 2. Singleplot layout

2.3 Estimation of various uniformity aspects of drip irrigation system

Various uniformity aspects of water application through surface drip irrigation system were calculated two times *i.e.*, at the initial stage (immediate after installation of irrigation system) and at the later stage (at the time of planting) in both seasons of experiment. Randomly one emitter was selected from a single plot and total twelve plots were incorporated for each test. Catch can method (Figure 3) was used for collection of outflow from dripper at constant pressure. Bowls were placed below the emitter and after six minutes, collected water was measured with the help of measuring cylinder during each test. On the basis of data regarding time duration and quantity of water collection, average emitter outflow rate as well as various uniformity aspects *viz.*, coefficient of variation (CV), distribution uniformity (DU), statistical uniformity (SU) and coefficient of uniformity (CU) were estimated by formulas described below [11].



Placement of bowl at initial stage in filed



Placement of bowl at later stage in filed



Emitter outflow collection



Measurment of collected outflow

Figure3. Catch cane method for measuring emitter outflow

CV was calculated by following formula.

$$CV = \frac{s}{\bar{q}}$$

Where,

CV = coefficient of variation

s = standard deviation of emitters discharge (lph)

\bar{q} = mean emitter flow rate (lph)

CV value < 0.05 is considered as excellent. While, value between 0.05 - 0.07 indicates marginal condition of surface drip irrigation system.

DU was calculated by following formula.

$$DU = \left(\frac{q_{1q}}{\bar{q}} \right) \times 100$$

Where,

DU = distribution uniformity

q_{1q} = mean of lowest one-fourth of emitter discharge (lph)

\bar{q} = mean emitter flow rate (lph)

DU of 90 % - 95 % is considered as good for surface drip irrigation system on land having slope of about 2 %.

SU was calculated by following formula.

$$SU = \left(1 - \frac{S}{\bar{q}}\right) \times 100$$

Where,

SU = statistical uniformity

q_{li} = mean of lowest one - fourth of emitter discharge (lph)

\bar{q} = mean emitter flow rate (lph)

SU > 90 % is considered as excellent. While, < 60 % SU is unacceptable.

CU is considered as best measure for evaluation of uniformity of surface drip irrigation system. CU was calculated by following formula.

$$CU = \left(1 - \frac{\sum_{i=1}^n |q_i - \bar{q}|}{N\bar{q}}\right) \times 100$$

Where,

CU = coefficient of uniformity

q_i = outflow rates of individual emitter (lph)

\bar{q} = mean emitter flow rate (lph)

N = total number of experimental emitters

CU score > 90 % is considered as excellent in regards to even distribution of water through emitters in surface drip irrigation system. While, 80 % - 90 % and 70 % - 80 % score is considered as good and average, respectively. Whereas, < 70 % score is considered as poor.

3. RESULT AND DISCUSSION

Data on mean emitter outflow rate through catch can method for both the experimental seasons was described in Table 1. The mean emitter flow rate was noted 1.97 lph at the initial stage and at later stage it was 2.63 lph during first experimental season. Same data in second experimental season was recorded 2.29 lph at initial stage and that of it was 2.99 lph at later stage.

Table 1: Mean emitter outflow rate through catch can method in both the experimental seasons

Number of bowls used as catch cans	First Season (2021-2022)				Second Season (2021-2022)			
	At the initial stage		At the later stage		At the initial stage		At the later stage	
	Quantity of water catched in six minutes (ml)	Discharge rate (lph)	Quantity of water catched in six minutes (ml)	Discharge rate (lph)	Quantity of water catched in six minutes (ml)	Discharge rate (lph)	Quantity of water catched in six minutes (ml)	Discharge rate (lph)
1	200	2.00	265	2.65	220	2.20	310	3.10
2	190	1.90	260	2.60	225	2.25	310	3.10
3	180	1.80	275	2.75	230	2.30	300	3.00
4	190	1.90	260	2.60	250	2.50	300	3.00
5	200	2.00	266	2.66	220	2.20	290	2.90
6	200	2.00	275	2.75	200	2.00	320	3.20
7	200	2.00	265	2.65	235	2.35	300	3.00
8	210	2.10	270	2.70	240	2.40	280	2.80
9	200	2.00	275	2.75	220	2.20	300	3.00

10	200	2.00	240	2.40	230	2.30	300	3.00
11	190	1.90	260	2.60	250	2.50	270	2.70
12	200	2.00	250	2.50	230	2.30	310	3.10
Mean emitter flow rate (\bar{q})		$\bar{q} = 1.97$	-	$\bar{q} = 2.63$	-	$\bar{q} = 2.29$	-	$\bar{q} = 2.99$

Data regarding various uniformity aspects of surface drip irrigation system for both the seasons were outlined in Table 2. All the data regarding various uniformity aspects showed excellent condition of surface drip irrigation in regards of uniform distribution of water through emitters at each observation stage for both experimental seasons. Here, the mean emitter out flow rate as well as CU was observed improved at second stage of observation *i.e.* after planting during both the experimental seasons that might be due to the reason that on the basis of data at the initial stage, several improvements in the aspects of drip laterals cleaning and pressure regulation were done which ultimately leads to improved uniform emitter flow rate and CU. The similar outcomes were also noted by Mohamed et al (2019) [12], Al-Ghobari (2012) [13] and Maroufpoor [14].

Table 2: Various uniformity parameters of surface drip irrigation system in both the experimental season

Experimental year	Coefficient of uniformity (CU)(%)		Distribution uniformity (DU)(%)		Statistical uniformity (SU)(%)		Coefficient of variation (CV)	
	At the initial stage	At the later stage	At the initial stage	At the later stage	At the initial stage	At the later stage	At the initial stage	At the later stage
2021-2022	96.89	97.02	95.59	94.91	96.04	96.00	0.04	0.04
2021-2022	95.58	96.80	93.82	95.26	93.91	92.39	0.06	0.04

Change in data of various uniformity aspects under surface drip irrigation system from initial to later stage for both the experimental seasons were depicted in Figure 4. Here, upper arrows are for first experimental season while, lower arrows are for second experimental season. We can clearly observe that except DU(%) and SU(%) in first experimental season all the parameters maintained uniformity with non significant improvement during the tenure of experiment. This uniform values of DU, SU and CU along with lower CV shows that installation and maintenance of drip irrigation system was done in proper way and working condition of system was excellent for uniform application of water to avail benefits of surface drip irrigation system. Critical role of precise maintenance in regards of uniform application of water through drip irrigation system was also advocated by Ascough and Kiker (2002) [15] and Ella et al. (2008) [16].

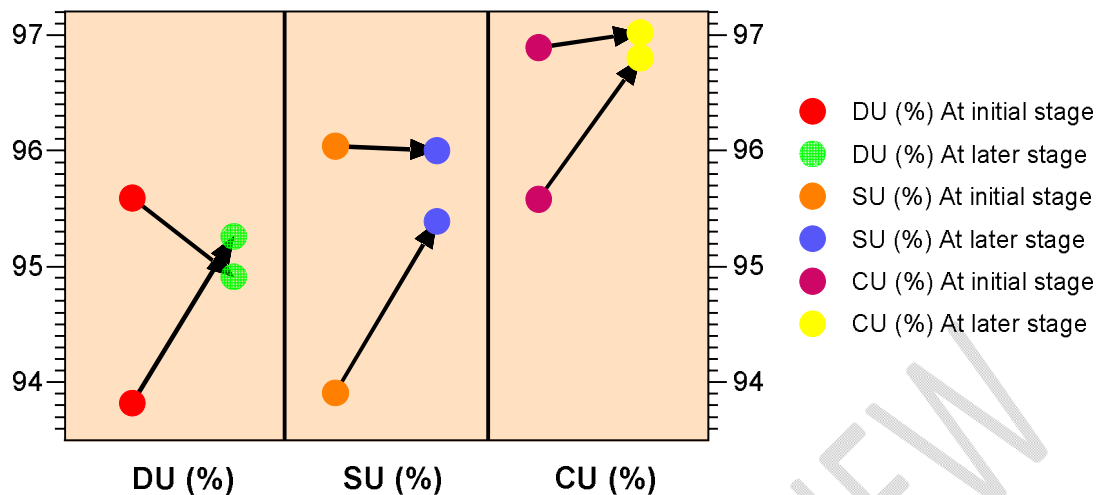

Figure 4. Comparison between initial and later stage data of various uniformity aspects

4. CONCLUSION

Based on the findings of study, it can be concluded that adequate maintenance of drip system units can effectively maintain or improve the Coefficient of uniformity (CU) of surface drip irrigation system which in turn results in a uniform distribution of water across the field and more efficiently utilize the advantages of surface micro irrigation systems.

REFERENCES

1. ChampaneriDD, Patel NK, Desai CS, Tandel BM. Economics of Indian bean [*Lablab purpureus* (L.) Sweet] production influenced by application of Novel organic liquid nutrient and Novel Plus organic liquid nutrient. *Asian Journal of Agricultural Extension, Economics and Sociology*. 2020;38(9):121-126. doi: <https://doi.org/10.9734/ajaees/2020/v38i930414>
2. ChampaneriDD, PatelNK, DesaiCS, DesaiDH. Efficacy of Novel organic liquid nutrient and Novel Plus organic liquid nutrient on quantitative traits of Indian bean [*Lablab purpureus* (L.) Sweet]. *International Journal of Plant and Soil Science*. 2021;33(17):105-115. doi: <https://doi.org/10.9734/ijpss/2021/v33i1730555>
3. ChampaneriDD, Patel NK. Photo selective shade net: An effective tool to reduce the impact of global warming and pesticide residues in vegetable production: A review. *Agricultural Reviews*. 2022;43(2):135-144. doi: <https://arccjournals.com/journal/agricultural-reviews/R-2363>
4. Moursy MAM, EIFetyany M, Meleha AMI, El-Bialy MA. Productivity and profitability of modern irrigation methods through the application of on-farm drip irrigation on some crops in the Northern Nile Delta of Egypt. *Alexandria Engineering Journal*. 2023;62:349-356. doi: <https://doi.org/10.1016/j.aej.2022.06.063>
5. GilbertRG, NakayamaFS, BucksDA, FrenchOF, AdamsonKC. Trickle irrigation: Emitter clogging and other flow problems. *Agricultural Water Management*. 1981;3(3):159-178, doi: <https://EconPapers.repec.org/RePEc:eee:agiwat.v:3:y:1981:i:3:p:159-178>
6. HassanliAM, AhmaddiradS, BeechamS. Evaluation of the influence of irrigation methods and water quality on sugar beet yield and water use efficiency. *Agricultural Water Management*. 2010;97(2):357-362. doi: <https://doi.org/10.1016/j.agwat.2009.10.010>
7. Koech R, Langat P. Improving irrigation water use efficiency: A review of advances, challenges and opportunities in the Australian context. *Water*. 2018;10(12):1771. doi: <https://doi.org/10.3390/w10121771>

8. Arshad I. Importance of drip irrigation system installation and management – A review. PSM Biological Research. 2020;5(1):22-29. doi: <https://psmpublishers.org/issues/importance-of-drip-irrigation-system-installation-and-management-a-review/>
9. Shi K, Lu T, Zheng W, Zhang X, Zhangzhong L. A review of the category, mechanism, and controlling methods of chemical clogging in drip irrigation system. Agriculture. 2022; 12(2):202. doi: <https://doi.org/10.3390/agriculture12020202>
10. PayeroJO, TarkalsonDD, IrmakS, DavisonD, PetersenJL. Effect of irrigation amounts applied with subsurface drip irrigation on corn evapotranspiration, yield, water use efficiency, and dry matter production in a semiarid climate. Agricultural water management. 2008;95(8):895-908. doi: <https://doi.org/10.1016/j.agwat.2008.02.015>
11. VeerannaJ, MishraAK, PatelN. Calculation of uniform coefficient, soil moisture distribution and analysis of level of biofilms strategy under sub surface drip irrigation. International Journal of Current Microbiology and Applied Sciences. 2017;6(10):713-726. doi: <https://doi.org/10.20546/ijcmas.2017.610.088>
12. Mohamed AZ, PetersRT, ZhuX, SarwarA. Adjusting irrigation uniformity coefficients for unimportant variability on a small scale. Agricultural Water Management. 2019;213:1078-1083. doi: <https://doi.org/10.1016/j.agwat.2018.07.017>
13. Al-GhobariHM. A comparison of water application uniformity for drip irrigation system above and below soil surface at various soil depths and scheduling techniques in arid region. WIT Transactions on Ecology and the Environment. 2012;168:311-322. doi: <https://doi.org/10.2495/SI120271>
14. Maroufpoor E, FaryabiA, GhamarniaH, MoshrefGY. Evaluation of uniformity coefficients for sprinkler irrigation systems under different field conditions in Kurdistan Province (Northwest of Iran). Soil and Water Research. 2010;5:139-145. doi: <https://doi.org/10.17221/42/2009-SWR>
15. Ascough GW, Kiker GA. The effect of irrigation uniformity on irrigation water requirements. Water SA. 2022;28(2):235-242. doi: <https://www.wrc.org.za/>
16. Ella VB, Reyes MR, Yoder R. Effect of hydraulic head and slope on water distribution uniformity of a low-cost drip irrigation system. Applied Engineering in Agriculture. 2009;25(3):349-356. doi: <https://doi.org/10.13031/2013.26885>