

# Development and research status of RV reducer

**Abstract:** With the rapid development of today's society and the continuous progress of science and technology, the arrival of the era of artificial intelligence is unstoppable, and the application of industrial robots in various fields has been widely promoted. One of the core technologies of industrial robots and one of the most important parts of its mechanical transmission part is the robot joint reducer. And RV reducer is a newly developed reducer. Compared with similar reducers, it has the advantages of large reduction ratio, small volume, high efficiency and strong bearing capacity, and is widely used in the fields of precision heavy-load transmission such as industrial robot joints, radar and CNC machine tools. At present, there is still much room for development in the fatigue life calculation of RV reducer in China. RV reducer occupies a core position in industrial robots and plays an irreplaceable role in the transmission and precise positioning of robots, so it is of far-reaching significance to study the fatigue life of RV reducer.

**Keywords:** industrial robot; RV reducer; fatigue life

## Introduction

### 1.1 Overview of RV reducer

With the "Made in China 2025" plan and the promotion of automation and information upgrading in the field of intelligent manufacturing, some high-end intelligent manufacturing equipment has gradually developed. As a key industry in the field of intelligent manufacturing, industrial robots have always been the focus of national attention [1]. Industrial robot is a high-tech equipment integrating advanced technologies of various disciplines, which can effectively reduce human labor intensity, improve manufacturing environment and enhance production efficiency. It is a powerful means to realize industrial automation and informatization, and plays an extremely important role in the field of intelligent manufacturing [2]. Domestic robot companies such as Xinsong and Eston are making great progress in the field of industrial robots, gradually breaking the dominance of traditional robot powers such as Japan, Europe and America. But this does not mean that China has won a complete victory in the competition in the field of industrial robots. In fact, there is still a big gap between China and foreign giants in the core technologies and components of industrial robots [3].

The most commonly used precision reducers for industrial robots are RV reducers and harmonic reducers, while the RV reducers produced by Japanese company Nabotsk and harmonic reducers produced by monaco have reached more than 70% of the market share [4]. The monopoly of foreign enterprises in the technology of robot core components such as precision reducer directly restricts the development of domestic industrial robot industry [5]. RV transmission is a crank type gear train transmission with less tooth difference developed on the basis of cycloidal pinwheel action. Its transmission theory was first put forward by Teijin Seiki Corporation of Japan in 1980, and it was widely used to manufacture RV reducers in 1986. Because of its special transmission mode, RV transmission can usually obtain higher bearing capacity, rotational stiffness and smaller structural size, so it is widely used in various high-precision equipment. In the field of Japanese robots, there is a tendency to gradually replace the traditional cycloidal pinwheel and harmonic drive.

With the continuous development and improvement in the field of intelligent manufacturing, the performance requirements of advanced technology and equipment for reducers are gradually

improved. All countries have started technical competition in the field of advanced manufacturing equipment such as industrial robots, so the reducer used is required to be smaller in size and better in performance. However, the traditional planetary reducer and worm gear reducer are often difficult to meet the technical requirements of high-precision equipment because of their huge volume, heavy weight, low precision and poor repetitive positioning performance.

RV reducer consists of the front stage of a planetary gear reducer and the rear stage of a cycloidal pin-wheel reducer. Compared with the traditional reducer, RV reducer has the advantages of stable performance, high precision and high rigidity, and its market usage has increased rapidly. Its applications include industrial robots, CNC machine tool garages, mechanical rotating shafts, semiconductor equipment and precision packaging equipment. RV reducer is the most widely used in the field of industrial robots, and has become one of the three core technologies of industrial robots (reducer, servo system and drive and control system) [6].

The main advantages of industrial robots are high working accuracy, strong bearing capacity, high production efficiency and high quality products, so they are widely used. One of the core technologies of industrial robots and one of the most important parts of its mechanical transmission part is the robot joint reducer. At present, RV reducer and harmonic reducer are widely used in the joints of robots [7], and RV reducer is a newly developed reducer, which has the advantages of large reduction ratio, small size, high efficiency and strong bearing capacity compared with similar reducers [8], and is widely used in the fields of precision heavy-load transmission such as industrial robot joints, radar and CNC machine tools. Considering the advantages of RV reducer, RV reducer is usually installed in the frame, arm and shoulder of industrial robot to bear heavy load.

### **1.2 RV reducer structure**

RV reducer is widely used in industrial robot industry and other fields, with the advantages of integrated structure, large transmission ratio, strong bearing capacity, stable transmission and high transmission efficiency. The structure of its reducer is shown in Figure 1. According to the order of power flow transmission, starting from the input end, it includes sun gear, involute planetary gears (two or three), crankshaft (two or three), cycloidal gears (two pieces), pin gear, cranked cylindrical roller bearings of planetary carrier crankshaft (four or six), tapered roller bearings supported by crankshaft (four or six) and angular contact ball bearings supported by planetary carrier (two).



Fig. 1 schematic diagram of RV reducer

### 1.3 transmission principle of RV reducer

RV reducer is a new type of closed differential gear train transmission device, and its transmission mechanism diagram is shown in Figure 2. It is mainly composed of two parts: high-speed stage and low-speed stage. The high-speed stage is involute gear transmission and the low-speed stage is cycloidal pin-wheel transmission. The motor is controlled to input clockwise from the right end of the high-speed stage. When the needle gear housing is fixed and the walking frame is used as the output inch, the rotation of the central wheel drives the planetary wheel to rotate and revolve, thus realizing the first-stage deceleration; The planetary gear and the crank shaft are fixedly connected together, and the crank shaft transmits the movement of the M-row wheel to the low-speed stage, and the rotation of the crank shaft against the inch needle drives the cycloidal gear to make counterclockwise revolution, and the cycloidal gear will also make clockwise rotation when the needle teeth engage with the cycloidal gear against the m-row needle revolution; The rotation of the cycloid wheel drives the crankshaft to rotate clockwise, and the revolution of the crankshaft drives the planetary carrier to rotate clockwise, and the rotation of the planetary carrier is output from the left end of the low-speed stage to realize the second-stage deceleration.

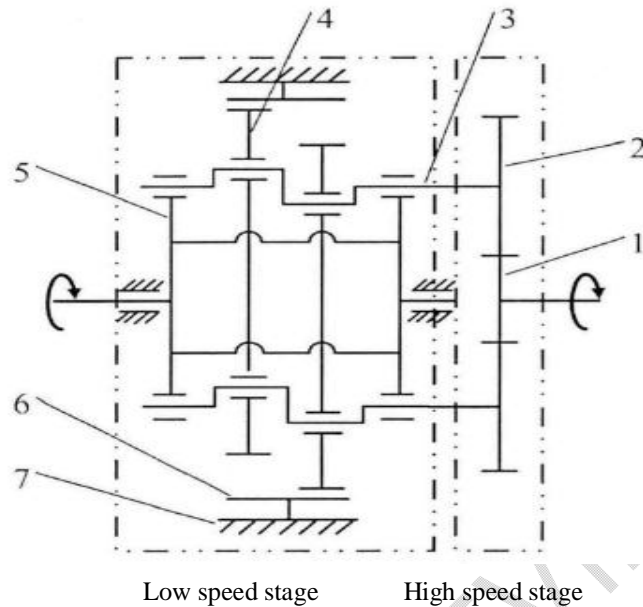

1. Central wheel; 2. Planetary wheel; 3. Crankshaft; 4. Cycloidal wheel;  
5. Planetary carrier; 6. Needle teeth; 7. Needle tooth shell

Figure 2 RV transmission mechanism diagram

### 2.1 RV reducer research status abroad

Since the appearance of crank-type transmission device in the early 1950s, Japanese scholars made great efforts to study the three-crank closed differential gear train transmission device in the 1960s. Since then, the structure and transmission performance of the device have been continuously improved, with many advantages such as compact structure, light weight and high transmission accuracy [8]. After 1980, with the introduction of RV transmission theory, Teijin Seiki Co., Ltd. of Japan began to study the precision reducer with high precision and high torsional stiffness used in industrial robot joints. Until 1986, Teijin Seiki Corporation of Japan officially mass-produced the eccentric differential RV reducer and obtained relevant patents. In the same year, France also released a planetary reducer with involute gear and cycloidal pin wheel similar to RV transmission principle. At present, in some manufacturing powers, RV reducers have been widely used in high-precision equipment such as industrial robots, forming a considerable industrial scale. One of the most famous Corporation (formerly Teijin Seiki Corporation) and Sumitomo Corporation of Japan, whose RV reducer products occupy the vast majority of the global market [9].

With regard to the technical research on the transmission accuracy of RV reducer, Korean scholar Joong-Ho Shin and others [10] put forward a design method of high-precision cycloidal gear by using the instantaneous center principle and homogeneous coordinate transformation, simulated and analyzed the working process of cycloidal gear, and wrote a computer program to verify the feasibility of the proposed method. Sensinger et al. [11], a European and American scholar, put forward the optimization design algorithm of reducer for the purpose of simplifying structure and improving efficiency, explained the source and influence of tolerance, and put forward the formula equations of stress, efficiency and moment of inertia. Wu Xinhui and He Weidong of Dalian Jiaotong University [12] completed the rigid-flexible coupling simulation modeling of virtual RV reducer by using computer simulation analysis technology, solved the sensitivity of various factors

of the whole machine to transmission accuracy, and studied the transmission accuracy characteristics of the whole machine based on the influence of multiple error factors by using orthogonal test technology. In addition, the grating method was used to verify the test and compare the results of simulation analysis, thus perfecting the simulation model. Guo Peilin of Chongqing University [13] studied the influence of cycloidal gear tooth profile modification, manufacturing deviation and actual load on the accuracy of the whole machine in RV reducer, and showed that compound modification is superior to single modification in improving the dynamic transmission accuracy, and the measured results on the RV reducer transmission test bench proved the correctness of the analysis results. According to the principle of force and torque balance, Zheng Yuxin, a scholar of Tongji University, established a crankshaft stress model with cycloidal wheel angle and crankshaft angle as variables, and based on this model, analyzed the effects of transmission elastic error and crankshaft eccentricity error on the overall transmission accuracy, and put forward the conclusion that the crankshaft eccentricity error with negative change will lead to its stress increase and transmission accuracy improvement. Zhang Jin [14] of Harbin University of Science and Technology put forward 18 important factors that affect the backlash of RV reducer, and established the mathematical model of these factors for the backlash of the whole machine. By using the methods of probability theory and mathematical statistics, the digital characteristics of each factor and the corresponding inverse transformation formula were deduced, and the backlash of the whole machine was obtained.

In addition, based on the analysis conclusion of back difference sensitivity, the error factors with high sensitivity are effectively controlled, and the corresponding design principles of parts accuracy are put forward.

Naren Kumar, an Australian scholar, and others put forward a new research method [15], including analysis and numerical technology. According to the static experimental results on the cycloidal pinwheel drive sold in the market, the elastic torsional stiffness of the single-stage cycloidal pinwheel drive is effectively determined. By establishing the dynamic model of the system, the satisfactory natural frequency of torsional vibration is obtained, which provides a basis for the realization of dynamic optimization design. LiXin Xu et al. established a multi-tooth meshing contact model of cycloidal pin-wheel drive. Firstly, the profile curve of cycloidal gear was discretized into several discrete points, and then the contact conditions between these discrete points and each pin tooth were determined by writing a program, and the contact area, maximum contact depth and contact load were calculated in turn. Deyu Su established a rigid-flexible coupling finite element model by using finite element method, and analyzed and obtained the meshing equivalent stress of cycloidal pin-wheel drive. Japanese scholar Yoshika et al. [16] proposed a method to suppress the speed vibration caused by the angular transmission error of industrial robot cycloidal gear. The proposed speed vibration compensation method used a new extended state observer, which was based on the cycloidal gear model with angular transmission error. The experimental results showed that the system suppressed the vibration of load speed. Jonathon W. Sensinger, an American scholar, compares and analyzes the advantages and disadvantages of harmonic drive and cycloidal pin-wheel planetary drive, including the performance of maximum transmission ratio, efficiency, gear backlash and dynamic inertia, etc., and makes the actual prototype and compares it, and draws the conclusion that cycloidal reducer has thinner size, higher efficiency and smaller meshing backlash. Shuting Li completed the automatic drawing of 2 D drawings and 3 D graphics of cycloidal pin-wheel reducer by AutoCAD software, and put forward a new mechanical model

and finite element method, developed a software for contact analysis of cycloidal pin-wheel reducer, successfully analyzed the contact of loaded gear of cycloidal gear reducer, and solved the problem of calculating and evaluating the camber of reducer. Polish scholar Jerzy Nachimowicz and others introduced the modeling process of cycloidal gear, and drew a graph with scattered points and smooth lines through the parameters of the complete profile of cycloidal gear teeth (including transmission ratio, eccentricity, pin tooth diameter, epicycloidal reduction ratio, central circle radius, etc.), thus showing the complete conjugate meshing profile of cycloidal gear. Japanese scholar TSAI Shyi-Jeng and others put forward a new compact design of three-stage differential cycloidal planetary gear transmission based on the concept of so-called RV reducer for high reduction ratio, discussed the new design structure and load characteristics, and analyzed and discussed the influence of two types of mechanisms and crank arrangement on sharing load, contact stress and transmitting torque acting on multiple pairs of teeth.

At present, a set of relatively complete analysis theory has been formed in the transmission technology of RV reducer abroad. In the 1920s, Lorenz Baraen[7] took the lead in putting forward the theory of cycloidal transmission. In the 1960s, Kudloptsev, an expert from the former Soviet Union, put forward the force analysis model of standard cycloidal gear on the basis of Lorenz Baraen. In 1989, American scholars Yang and Blanche[8] studied the kinematic relationship among tolerance, driving parameters (gear ratio, standard tooth height and pitch diameter) and performance indicators (backlash and torque fluctuation) with the help of computer-aided analysis, which was used to estimate the backlash and torque ripple of a given reducer. In 2002, Yan and Lai[9] derived the meshing equation based on coordinate transformation, triple vector product of differential geometry and conjugate surface theory. A program is developed to solve the conjugate surface equation. In 2003, Chang[10] established the mathematical model of epicycloidal gear driven by cycloidal pin wheel with less tooth difference, and deduced from the differential geometry theory that the pressure angle affects the direction and magnitude of force transmission of cycloidal gear. In 2007, He et al. [11] established a multi-degree-of-freedom spur gear model considering sliding friction and time-varying stiffness. Under the influence of sliding friction, the influence of profile modification on dynamic transmission error was analyzed. In 2009, Al-Shyab [12] established a nonlinear torsional dynamic model of composite planetary gear train structure with time-varying meshing stiffness by using the hybrid harmonic balance method (HBM) and the conjugate theory of inverse Fourier transform, and demonstrated the effectiveness of the model and the solution method. In 2012, Kim et al. [13] regarded pressure angle and contact rate as time-varying variables, proposed a new dynamic model of planetary gear, deduced its nonlinear motion equation, calculated its dynamic response by Newmark time integration method, and studied the influence of bearing stiffness on pressure angle and contact rate. In 2016, Wei et al. [14] established a mixed lubrication model considering the geometric shape, contact load, tooth surface roughness and transient effect of the contact area between the needle tooth and the cycloid wheel. The effects of normal load, radius of curvature of meshing point, radius of pin teeth and speed on lubrication conditions are studied. The results show that the change of radius of curvature in a small range has no significant effect on lubrication. In 2017, Li et al. [15] considered the assembly error, clearance fit and elastic deformation, established an analytical model of the reducer based on the nonlinear Hertz contact stiffness method, and analyzed the influence of radial and pin hole clearance and eccentricity error on contact stress, transmission error, transmission ratio and bearing load. Huang et al. put forward a calculation model of loaded tooth contact analysis (TCA) based on the influence coefficient method.

The contact point was determined according to the instantaneous velocity center in the model. Considering the friction of the contact tooth surface and the stiffness of the cycloidal gear support bearing, the coupling influence of load on involute and cycloidal gear pair was analyzed, and the correctness of the model was verified by experiments. In 2019, Artyomov et al. put forward an analytical judgment on the load distribution on the cycloidal gear teeth, the maximum force acting on it and the friction loss when the cycloidal gear teeth contact with the pin teeth in planetary cycloidal gear transmission. The calculation relationship of load increase coefficient caused by clearance and the influence of gear clearance on sliding friction loss are obtained. The calculation results of load increase coefficient and clearance influence coefficient on friction loss in gear transmission are given. Xu et al. [16] put forward a generalized dynamic model of bearing-cycloid-pin wheel transmission mechanism, and studied the dynamic contact response and internal contact of the geometric parameters of cycloid gear and radial arm bearing.

The influence of load transfer characteristics, determine the contact position, calculate the contact load, update the generalized force acting on the system, and reassemble the dynamic equation of the system; Ali et al. [17] proposed to use the embedded current signal of the control unit (MCSA) as a method to detect and diagnose mechanical faults. Based on wavelet characteristics and statistical analysis, the current signal is analyzed in time frequency, and the current signal is decomposed into wavelet, and the features are extracted for classification based on machine learning. It shows satisfactory results in the fault detection and diagnosis of RV reducer, and the classification accuracy is 96.7%.

## **2.2 Domestic research status of RV reducer**

Zhang Wenwei of Anhui University of Engineering and others [18] established the finite element model of cycloidal pin-wheel planetary reducer by using finite element method, and analyzed its contact stress by finite element method, and obtained the simulation calculation results of contact stress of cycloidal gear. Based on Miller's linear damage accumulation theory in fatigue life analysis theory, the life cloud map and life safety factor distribution cloud map of cycloidal gear were obtained by using fatigue life simulation software, and the minimum safety factor was 0.53121. After calculation, the stress cycles of various parts of cycloidal gear were obtained, and the minimum stress cycles were 50. Yao Canjiang of north china university of technology first established the three-dimensional solid model of RV reducer by using the three-dimensional drawing software Proe, and then imported it into the finite element analysis software ANSYS-Workbench for transient dynamics simulation analysis, including the analysis of key components such as cycloid wheel, bearing and crankshaft, and obtained the stress simulation calculation results, and made further fatigue life reliability analysis based on the basic data. The analysis results show that the reliability of all components of RV reducer is in a high state, and the reliability of the whole machine is high. Han Ju et al. [19] of North China University of Science and Technology deduced the equivalent contact stiffness model of single pair of gear teeth meshing of cycloidal pin-wheel drive according to Hertz contact mechanics theory, and determined the single tooth meshing parameters of cycloidal pin-wheel drive of RV reducer by taking into account the factors such as the number of gear teeth engaged at the same time, the amount of cycloidal gear practice and the central circle error of pin teeth. The analysis results show that the meshing stiffness of cycloidal pin-wheel drive of RV reducer changes with time, and the number of teeth of pin-wheel engaged at the same time is far less than half, and the number of teeth engaged at the same time increases with the increase of load. According to the finite element method, Wu Xinhui of Dalian

University for Nationalities and others established the finite element model of each part of RV80E reducer by using the finite element analysis software ANSYSAPDL, and assembled each part to get the finite element model of the whole RV reducer. The geometric errors of various models were considered in the modeling process, and finally the finite element simulation analysis was carried out. The analysis results show that the stress of the cycloid wheel under the comprehensive influence of various error factors is obtained, and the parametric modeling of RV reducer is feasible. [20]Han Linshan of North China Institute of Water Resources and Hydropower and others used the numerical calculation function of Matlab, based on the interference theory of stress intensity distribution, and adopted the Monte Carlo simulation method to analyze the fatigue strength of cycloidal gear of RV reducer, and established the calculation model of fatigue reliability of cycloidal gear. [21]Xi Ying of Tongji University and others established the meshing stiffness models of the first-stage involute gear drive and the second-stage cycloidal pin-wheel drive of RV reducer, calculated the meshing stiffness values by Matlab, verified the interference of the whole model by CATIA, and imported the verified model into Adams for dynamic dynamics simulation analysis. Through simulation analysis, the transmission errors, acceleration values and stress values of RV reducer were obtained, which provided certain reference value for theoretical calculation and experimental reference. According to the operating principle and structure of RV reducer and the static stress principle of mechanics, Zhang Zhenqiang et al. [22]of Luoyang Shaft Research Technology Co., Ltd. made a stress analysis on the crank arm bearing, the crank shaft supporting tapered roller bearing and the main bearing of RV reducer. The analysis results show that the main shaft of RV reducer bears the greatest stress, followed by the crank arm bearing and the crank shaft tapered roller bearing with the least stress. Wang Rui of Zhengzhou University and others made a theoretical analysis of the stress on the cycloid wheel, calculated the theoretical meshing force of each tooth of the cycloid wheel, and calculated the simulated meshing force by using the finite element simulation method, obtained the stress distribution of the tooth profile, and checked the stress intensity. [23]Lu Bo of Harbin University of Science and Technology conducted an accelerated fatigue life degradation experiment for RV reducer, and obtained the reliability experimental data of RV reducer through the experiment. The reliability function of RV reducer was obtained by Matlab, and the degradation model was established based on Brownian motion principle and compared with the life function of RV reducer. [24]Luo Yu and others of Guizhou University took an RV reducer used in an excavator as an example, analyzed the contact fatigue strength of the cycloid wheel in the RV reducer, and compared it with the theoretical calculation results, and obtained the maximum contact stress, and the maximum elastic strain occurred in the empty space of the cycloid wheel bearing. The analysis results showed that there was no fatigue failure during the meshing process between the cycloid wheel and the pin teeth.

### **3 conclusion**

In recent years, some domestic robot enterprises have invested a lot of manpower and funds in the development of reducers. After continuous experience accumulation and technical precipitation, they have made gratifying progress in standardization construction, and have gradually gained recognition in the international market, and their product competitiveness and sales volume have continued to increase. But this does not mean that China has broken the monopoly of industrial powers such as Europe, America and Japan and reached the manufacturing level of manufacturing powers. In fact, there is still a big gap between domestic industrial robot products and foreign products in terms of core technology and core components. In 1980s, industrial robots were

included in the national "Seventh Five-Year Plan". After nearly forty years' efforts and development, some proud achievements have been made, but compared with foreign products, they still cannot meet some precision requirements in production tasks, especially in transmission accuracy and torque stiffness. The development of domestic RV reducers has a long way to go.

## References

- [1] Zhang Yue. Research on interpolation algorithm and calibration technology of industrial robots. [Master's degree thesis of Jiangxi University of Science and Technology]. Ganzhou: Jiangxi University of Science and Technology, 2017: 3-20.
- [2] Wang Tianmiao, Tao Yong. China's industrial robot technology status and industrialization development strategy. *Journal of Mechanical Engineering*, 2014, 50(9): 1-13
- [3] Zheng Weifeng. Research on performance testing platform of RV reducer. *Research on quality and technical supervision*, 2016, (4): 26-29
- [4] Huang Xing, He Wenjie, Fu Yuanxiang. Overview of industrial robot precision reducer. *Machine Tool and Hydraulic*, 2015, 43(13): 1-6
- [5] Yu Ziqiang. Analysis of meshing characteristics of RV reducer: [Master's degree thesis of Chongqing University]. Chongqing University, 2018: 1-20
- [6] Chao Huang. Dynamic characteristics analysis and nonlinear vibration research of planetary reducer with few tooth differences: [Doctoral thesis of Chongqing University]. Chongqing University, 2013: 1-12.
- [7] Lv Mingshuai. Simulation and experimental study on transmission characteristics of RV reducer: [Master's degree thesis of Harbin Institute of Technology]. Harbin: Harbin Institute of Technology, 2016: 1-3
- [8] An S E, Park S H, Yang H D. Mechanism Design for a Dual Cycloid Reducer. *Applied Mechanics & Materials*, 2012, 121-126(7): 49-53
- [9] Shin J H, Kwon S M. On the lobe profile design in a cycloid reducer using ins tant
- [10] Sheu K B, Chang C F, Chiou S T. Kinetostatic analysis of cycloid drives, 2003:
- [11] Pascale L, Patic P C. Cycloid Reducers Study Applied on Orientation Mechanism. *International Conference on Robot*, 2011: 27-31.
- [12] Thube S V, Bobak T R. The Dynamic Simulation and Analysis of a Cycloidal Speed Reducer. *ASME 2011 International Design Engineering Technical Conferences and Computers and Information in Engineering Conference*, 2011: 471-479.
- [13] Sensinger J. Efficiency of High-Sensitivity Gear Trains, Such as Cycloid Drives. *Journal of Mechanical Design*, 2013, 135(7): 1-9
- [14] Parker R G. Modal properties of planetary gears with an elastic continuum ring gear. *Journal of Applied Mechanics*, 2008, 75(3): 031014
- [15] Eritenel T, Parker R G, Vibration. Modal properties of three-dimensional helical planetary gears. *Journal of Sound*, 2009, 325(1): 397-420
- [16] Miner MA, Ball and Roller, Bearing Engineering[M].SKF Industries, 1945, 159-164.
- [17] Cavallaro G P, Wilks T P, Subramanian C, et al. Bending fatigue and contact Fatigue Characteristics of carburized gears[J]. *Surface & Coatings Technology*, 1995, 71(2): 182-192.
- [18] Zhang Wenwei, Gao Hong, Zhang Wei. Contact fatigue analysis of cycloidal pinwheel reducer based on finite element analysis method. *xinxiang university study Newspaper*

2017,34 (3): 45-47

[19] Yao Canjiang. Reliability research of RV reducer and fatigue reliability analysis of key

parts: (Master's degree thesis). north china university of technology. 2017: 1-4.

[20] Han Ju, Wang Xiaohu, Liang Liming. Simulation analysis of meshing characteristics of cycloidal pin wheel transmission part of RV reducer. Mechanical transmission. 2017,41 (11);120-125.

[21] Wu Xinhui, Liu Keying, Feng Changjian. Force analysis of cycloidal gear based on finite element assembly model of RV reducer. Dalian University for Nationalities Newspaper .2017,19 (3): 223-226

[22] Han Linshan, Ke Chao, Qi Caijuan. Reliability analysis of fatigue strength of cycloidal gear of 2K-V reducer based on MATLAB. Mining machine Machinery. 2013,41 (4): 131-134

[23] Xi Ying, Yuan Lang, Zheng Yuxin. Research on dynamics simulation of RV reducer for robot based on ADAMS. Journal of China Mechanical Engineering .2018,16(1):43-48

[24] Wang Rui, Chen Jiangyi. Finite element analysis of cycloidal gear in RV reducer. Mechanical manufacturing. 2017,55 (635): 61-64.

UNDER PEER REVIEW