

Role of Problematic Internet Use and Cognitive Overload in Cyberchondria among adult IT professionals

ABSTRACT

The present study was conducted to explore the role of problematic internet use and cognitive overload in cyberchondria among adult professionals working in IT, media & advertising sectors. A sample of 203 (118 men, 78 women) was drawn by means of purposive sampling. The severity of cyberchondria was assessed by using cyberchondria severity scale, problematic internet use by scale and cognitive overload by information overload questionnaire. The significance of the hypotheses was analyzed using Spearman correlation coefficient analysis, Mann Whitney test U test. Results revealed both problematic internet use and cognitive overload was positively correlated with cyberchondria. Furthermore, cyberchondria showed a significant difference between males and females in which females had a higher level of cyberchondria and were more likely to experience health related symptoms than males.

Keywords: *problematic internet use, cyberchondria, cognitive overload, adult professionals*

Introduction

we live in the cyber-age, depending on the internet for faster and convenient modes of functioning in wider walks of our lives. The world has increasingly become computerized and we look up to perform tasks, communicate information digitally. Sadly, internet endowment has a perilous side to it as well. As per internet penetration rate in India (2007-2021) half of total population had access to the internet. India emerged as 2nd in the list of active users of the internet globally as per the report ('India: Internet penetration rate 2021,' 2021). The ongoing COVID-19 pandemic mandated lockdown and social-withdrawal contributed to a significant surge of internet-usage to 61% in 2021 as per recent survey. Health-seeking information from the internet has increased manifold as such information is available quickly and anonymously avoiding any hurdles. It doesn't cost a penny to enquire about anything and get answers from the web (Starcevic et.al., 2013). This on one hand enables people to have perceived control over life-situation and a seamless communication is established between medical-expert and people enabling them to participate in the process (Starcevic et.al., 2013). Potential risk emerges when these online searches for health-related information become excessive and turn stressful to the person. Cyberchondria can be defined as hypochondriasis-like symptoms induced by digital usage of computers or internet-consumption. What began as a behavior to relieve health symptoms and pain converts into an unnecessary and repetitive habit of online searching for information pertaining to health. It worsens the purpose and becomes anxiety-provoking to the person. 71% of nationwide samples confirmed using the internet and 44% of them particularly used online searches as a health diagnostic medium (Andreasson et.al., 2007). Such compulsive searching behavior causes enhanced health anxiety and worry about health (Taylor et.al., 2004). Problematic internet use has been defined as failure to keep a check on consuming internet accompanying adverse consequences (Spada, 2014). When this health anxiety occurs as a result of internet searching behavior pertaining to health, it takes the form of cyberchondria. Given the nature of the digital age, we experience a surplus amount of information leading to information overload which becomes an impediment rather than an aid (Bawden et.al., 2008). Study points out the phenomenon of too much information causing reduced performance at work and adverse effects on health. This hints towards what is termed as 'infodemic' whereby occurrence of excessive amounts of information makes it difficult for people to disperse facts from fiction. Information load has been shown to cause negative states of anxiety and depressive symptoms (Swar et.al., 2017). WHO states amidst this viral pandemic we are fighting with an 'infodemic' where it gets immensely hard to separate genuine pieces of information from not so reliable ones ("Infodemic," 2020). Young and elderly populations seem to have access to the internet and resort to social media to find and share health information and (Tennant et.al., 2015), (Marchant

et.al., 2017). But, a study on age-correlates of the internet (Compaine, 2001) highlighting the divide among young and older population underwent recent examination stating complexities in the trend. Availability of personal cell phones and other devices equipped with the internet coupled with digital skills has enabled young population with internet connectivity and knowledge persisting the inequality (Gonzales, 2015), (Mariën & A. Prodnik, 2014), (Friemel, 2014).

Cyberchondria, identified in recent times as a separate phenomenon and is a form of health anxiety resulting from digital origin, is gaining research attention (Muse et al., 2012). It is likened to hypochondriasis in that it marks sources of exacerbated levels of worry or fear arising from internet use than age-old approaches like visit to a doctor's clinic (Hart & Björgvinsson, 2010). Cyberchondria is defined as persistent internet probing behavior for health-related information accompanying anxiety and negative affect of worry or apprehension about one's health (Jokic-Begic et al., 2020). But, a study by Te Poel et al., 2016 provided evidence that clinically eligible people for health anxiety don't seem to have increased anxiety by online health-seeking behaviors as seen in the general population. Ongoing COVID-19 pandemic induced virus anxiety was comparable to cyberchondria as they consumed unbridled media-information leading to elevated levels of anxiety (Jungmann & Witthöft, 2020). Problematic internet use (PIU) by (Fergus & Spada, 2017) established health anxiety as has been studied by Spada. 2014 and presents PIU as a relevant factor to both health anxiety (hypochondriasis) and cyberchondria. As stated, earlier health information searches can be motivated by other factors apart from health anxiety (Te Poel et al., 2016). Excessive online searches from abundant sources from the internet causing overload of information lead to increased levels of anxiety, distress and psychological ill-being (Misra & Stokols, 2011), (Swar et al., 2017).

Research showed possible linkage of problematic internet use to cyberchondria, yet no definitive study shows the direct cause (Starcevic & Berle, 2013), (Fergus & Dolan, 2014). Widespread spread of misinformation and cognitive overload have been connected to cyberchondria (Sweller et al., 2011), Laato et al., 2020). Cognitive overload decreases believability in others and causes loss of self-control and makes misinformed decisions by not being able to process information in the surrounding (Zhou et al., 2017), (Samson & Kostyszyn, 2015). Measuring cognitive load of people responding to online information is thus required to establish potential link to cyberchondria (Laato et al., 2020). As indicated by recent studies the possible population engaging with internet and related services implicated in cyberchondria is the young adult population (Mariën & A. Prodnik, 2014), (Friemel, 2014), (Gonzales, 2015). The present study aimed to examine the effect of cognitive overload and problematic internet use on cyberchondria in the adult population. It is hypothesized that problematic internet use can lead to overload (Laato et al., 2020). Further, cognitive overload was presumed to be a risk factor for developing cyberchondria symptoms (Sweller et al., 2011), Laato et al., 2020). The study assumed a correlation research design to explore different variables affecting cyberchondria.

METHODOLOGY

Objectives

- Does cognitive load act as a risk factor for experiencing cyberchondria like symptoms?
- Can problematic internet use cause cognitive load?
- What is the prevalence of cognitive load in younger and older adult cohorts?

Hypotheses:

H1: Problematic internet use has an effect on cognitive load experienced by internet users.

H2: Cognitive load has a positive effect on cyberchondria related symptoms.

H3: There will be a significant difference between younger and older adult age groups in terms of experiencing negative symptoms of cyberchondria.

Model:

Based on past literature, cyberchondria, problematic internet use, cognitive load and adult age can be hypothesized as (CYB, PIU, CO and adult age). PIU can lead to CO. Both PIU and CO can significantly cause/predict CYB in adult age groups.

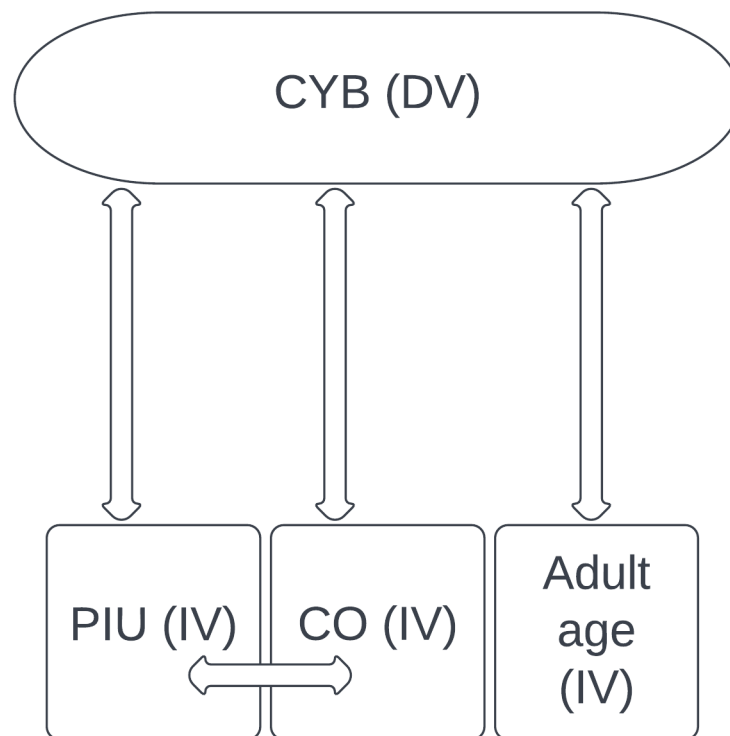

Fig 1. Hypothesized relationship between CYB with PIU & CO in adult age groups

Sample:

For the correlational study, purposive sampling was employed to select 1 working professionals from varied private and self-employed sectors involved in occupations which require them to use the internet and related products. The study presumes that workers consume the internet for longer intervals of time on a regular basis for work and self-related purposes. Two adult groups were made on the basis of occupational post/designation and work experience, namely younger and older age cohorts.

INCLUSION CRITERIA-

- The participants belonged to the age range of 25 and 60.
- Participants consume the internet and related products for more than 2-3 hours a day.
- Criteria for internet- consumption due to professional, personal or both reasons.

EXCLUSION CRITERIA-

- People who are already diagnosed with anxiety/mood disorders.
- Professionals who are not regularly employed/ part time workers/ weekly workers etc.

Measures:

McElroy and Shevlin, 2014 developed the 33-item Cyberchondria Severity Scale (CSS) a self-report instrument that allows for 5 multidimensional assessments of cyberchondria like compulsion, distress, excessiveness, reassurance, and mistrust of the medical profession. Over time the CSS has been proven to demonstrate excellent internal reliability (Cronbach alphas ranged from 0.75 to 0.95).

Problematic internet use questionnaire is an 18 items self-report instrument that was published in 2006 and was developed by examining different internet over gambling questionnaires. Multiple studies established high reliability (Cronbach alpha- .90) (Thatcher and Goolam (2005). It yielded the three-factor structure

- Obsession — being obsessed with Internet activities
- Neglect — neglecting non-internet activities
- Control disorder — unable stopping to use the internet

Perceived information overload scale is developed by Misra and Stokols, 2011 has generated good internal consistency (Cronbach Alpha, $\alpha = .86$) and good validity by results of the confirmatory factor analyses. The scale consists of a 16 item scale that measures two subscales of information overload, environment based and cyber-based information overload. The questionnaire divided into two parts follows a 5 points response on Likert scale.

Procedure:

The potential participants from varied occupational (e.g., IT, media/Advertising firms etc.) settings were contacted physically on the basis of the consumption of internet services on a regular basis and informed about the study. Informed consent and demographic forms were duly filled out by them. 194 Participants from two age groups (new adult gr-1 aged 21-30 and old adult gr-2 aged 31-64) on the basis of their occupational post/designation and time spent (experience) were given out the test of PIUQ, a self-report measure to assess the subjective level of problematic use of the internet. Same groups were asked to take the Perceived information overload questionnaire to assess cognitive load experienced while engaging in activities of internet-use either in professional or personal or both set-ups. After completion of the test, they were administered with the CYB severity scale measuring the severity of experienced negative health symptoms. Further, tests were analyzed using psychometric tools. The participants were sent google forms to take up the questionnaires.

RESULTS

The aim of the study is to explore the role of problematic internet use and cognitive overload in cyberchondria among adult age groups. It assessed the relationship between problematic internet

use and cognitive overload. The study also aimed to assess the prevalence of cognitive/information overload in adult age groups.

Table 1: Socio-demographic details of participants

Variables		N	Mean %
Age	Gr1 (aged 21-30)	76	39.1
	Gr2 (aged 31-64)	118	68.1
Gender	Male	120	61.8
	Female	74	38.1

Table 1 displays socio-demographic details of the participants in the study. The total number of samples is 194. There were 120 males and 74 females ranging in two groups of age 21-30 and 31-64 of IT/media professionals working for at least 5 years in the field.

The percentage of males and females were found to be 61.8% and 38.1% respectively. The percentage of two adult age groups were 39.1% and 68.1% respectively.

Table 2: Shapiro-Wilk Normality Test for Problematic internet use (PIU), Cognitive Overload (CO), and Cyberchondria (CYB)

Variables	Males	Females
PIU	.001	.024
CO	.001	.009

CYB

.001

.001

N= 194, $p = < .05$

Table 2 indicates that the sample of the study was 194 including 120 males and 74 females respondents. According to the Shapiro-Wilk test of normality, the sample was not normally distributed, due to which the non-parametric tests for analyzing the differences and correlation were used.

Table 3: Descriptive Statistics for Problematic Internet Use (PIU), Cognitive Overload 9(CO) and Cyberchondria (CYB) in adult age group

	Variables	M	SD
PIU	Gr1 (aged 21-30)	49.7	12.7
	Gr2 (aged 31-64)	52.2	16.8
CO	Gr1 (aged 21-30)	28.8	14.0
	Gr2 (aged 31-64)	32.5	19.5
CYB	Gr1 (aged 21-30)	12.9	3.23
	Gr2 (aged 31-64)	14.6	3.43

Gr1 N= 118, Gr2 N= 64

Table 3 shows the total number of participants in two adult age groups. PIU within the Gr1, N= 118 had a mean (M) of 49.7 and a standard deviation (SD) of 12.7, CO had a mean of 28.8 and a standard deviation of 14.0 and CYB had a mean of 12.9 and a standard deviation of 3.23 respectively. While PIU within Gr2, N=64 had a mean of 52.2 and a standard deviation of 16.8, CO had a mean of 32.5 and a standard deviation of 19.5 and CYB had a mean of 14.6 and a standard deviation of 3.43 respectively. The mean difference between two age groups was found to be greater in which Gr2 scored more on CO suggesting greater effect of CO in the Gr2 as outlined by the hypothesis.

Table 4: Correlation in Problematic Internet Use (PIU), Cognitive Overload (CO), Cyberchondria (CYB) and Adult Age.

Variables	CO (r_s)	CYB (r_s)	AGE (r_s)
PIU	.842	.435	

CO	-		
CYB	.442	-	
AGE		.245	-

(r_s)= Spearman's Correlation Coefficient, * * * $p = <.001$

To test the relationships between the variables, a Spearman Correlation Test was administered. Table 4 shows the correlation between PIU, CO and CYB in adult groups. The Spearman coefficient shows moderate positive correlation between CYB and PIU $r(201) = .43$, CYB and CO $r(201) = .44$, CYB and AGE $r(201) = .24$ at $p < .001$. There was strong positive correlation between PIU and CO $r(201) = .84, p < .001$.

Table 5 (a): Model Fit Measures

Model	R	R ²	Overall Model Test			
			F	df1	df2	p
1	0.853	0.727	512	1	192	<.001

Table 5 (b): Model Coefficients - CO

Predictor	Estimate	SE	t	p	Stand. Estimate
Interc	-19.0	2.308	-8.23	<.00	
ept	02	5		1	
PIU	0.977	0.043	22.64	<.00	0.853
		2		1	

Table 5 (a) presents the regression table indicating PIU is a significant predictor ($\beta = 0.85$, $p < .001$) of CO. Coefficient of determination ($r^2 = .72$) showed that variation of PIU can explain 72% variation in CO Table 5 (b). The model is adequately fit ($F = 512$, $p < .001$). This answers the 2nd research question and affirms the hypothesis saying that PIU can strongly predict the presence of CO.

Table 6 (a): Model Fit Measures

Model	R	R ²	Overall Model Test			
			F	df1	df2	p
1	0.439	0.193	45.8	1	192	< .001

Table 6 (b): Model Coefficients - CYB

Predictor	Estimate	SE	t	p	Stand. Estimate
Intercept	11.2633	0.4532	24.85	< .001	
CO	0.0859	0.0127	6.77	< .001	0.439

Table 6 (a) presents the regression analysis table which indicates CO is a significant predictor ($\beta = 0.43$, $p < .001$) of CYB. Coefficient of determination ($r^2 = .19$) showed that variation of CO can explain 19% variation in CYB. The model is adequately fit ($F = 45.8$, $p < .001$), Table 6 (b). This answers the 1st research question and affirms the hypothesis saying CO can mildly predict the presence of CYB.

DISCUSSION and CONCLUSION

The present study aimed to explore the role of problematic internet use and cognitive overload in cyberchondria among the adult age group of working professionals in IT, media and advertising sectors for at least 5 years in India. A sample of 194, consisting of 120 males and 74 females divided into two adult age groups namely Gr1 (aged 21-30) and Gr2 (aged 31-64). The study aimed to assess the relationship between problematic internet use and cognitive/information overload. It also assessed the prevalence of cognitive overload in adult age groups.

According to the findings of the study, there is a positive correlation between the variables. There is a moderate positive correlation among cyberchondria and problematic internet use and cognitive overload in adult age groups. The first research question is aptly answered by the positive correlation between variables by the findings of the study. Cognitive overload emerged as a significant but mild predictor of cyberchondria (CYB), explaining mildly the variation in CYB. This answers the first research question and affirms the hypothesis in predicting CYB and acting as a risk factor in cyberchondria. There exists a strong positive correlation between problematic internet use (PIU) and cognitive overload (CO). PIU emerged as a significant predictor of CO, explaining well the variation in CO. Thus, it answers the 2nd research question and affirms the hypothesis saying that PIU can strongly predict the occurrence of CO. prevalence of CO is greater in Gr2 descriptively seen by higher mean scores answers the third research question.

The study is particularly relevant to the context of adult working professionals in IT, media/advertising sectors which by their nature of the job consume more information on a day to day basis. Internet endowment and proficiency in their job makes them significantly prone themselves to use information available online and experience an information overload as maintained by past literature. Such factors can make internet usage complicated and troublesome to them and experience distress. The recent study thus highlights their positions being vulnerable to experience negative symptoms of health related anxiety.

Having undergone COVID-19 lockdown in a pandemic, they became more susceptible to interact with information online, negatively taking a toll on their ability to process and utilize it. The concerns and fear of viruses and physical ailment amid lockdown increase such consumption irrespective of the general population. Thus, study serves as clearing and consolidating the

picture of problematic internet use and cognitive overload impacting people to experience negative health symptoms of cyberchondria.

However, the study is not exempt from its limitations. The sample was not normally distributed thus making it hard to generalize outside the purposive population. The test-results are based on self-reports entailing the respondent's bias. Although variables have been identified as predicting another variable but are mild predictors signifying role or presence of other factors in occurrence of such variables in the general population.

The study highlights the reciprocal relationship between problematic internet use and cognitive overload with the former causing the latter. Having lost the ability to manage consumption of internet prones, individuals feel a sense of information overload which negatively impacts their health. Evidence of such experiences in older adult groups (above 31 years of age) can provide us with ideas of them developing negative health symptoms. Thus, it has clinical implications in understanding the presentation of the condition of cyberchondria and the factors which precipitate it. Similarly, work-related prevention strategies and programs relating to consumption should focus on its problematic use which can reduce subjective sense of overload and prevent problems from worsening.

Consent

As per international standard or university standard, respondents' written consent has been collected and preserved by the author(s).

REFERENCES

- Andreassen, H. K., Bujnowska-Fedak, M. M., Chronaki, C. E., Dumitru, R. C., Pudule, I., Santana, S., Voss, H., & Wynn, R. (2007). European citizens' use of e-Health services: A study of seven countries. *BMC Public Health*, 7(1). <https://doi.org/10.1186/1471-2458-7-53>
- Bawden, D., & Robinson, L. (2008). The dark side of information: Overload, anxiety and other paradoxes and pathologies. *Journal of Information Science*, 35(2), 180-191. <https://doi.org/10.1177/0165551508095781>
- Fergus, T. A., & Spada, M. M. (2017). Cyberchondria: Examining relations with problematic internet use and metacognitive beliefs. *Clinical Psychology & Psychotherapy*, 24(6), 1322-1330. <https://doi.org/10.1002/cpp.2102>
- *India: Internet penetration rate 2021*. (2021, February 11). Statista. <https://www.statista.com/statistics/792074/india-internet-penetration-rate/>
- Khazaal, Y., Chatton, A., Rochat, L., Hede, V., Viswasam, K., Penzenstadler, L., Berle, D., & Starcevic, V. (2020). undefined. *European Addiction Research*, 27(1), 58-66. <https://doi.org/10.1159/000510922>
- Marchant, A., Hawton, K., Stewart, A., Montgomery, P., Singaravelu, V., Lloyd, K., Purdy, N., Daine, K., & John, A. (2018). Correction: A systematic review of the relationship between internet use, self-harm and suicidal behaviour in young people: The good, the bad and the unknown. *PLOS ONE*, 13(3), e0193937. <https://doi.org/10.1371/journal.pone.0193937>

- Starcevic, V., & Berle, D. (2013). Cyberchondria: Towards a better understanding of excessive health-related internet use. *Expert Review of Neurotherapeutics*, 13(2), 205-213. <https://doi.org/10.1586/ern.12.162>
- Swar, B., Hameed, T., & Reychav, I. (2017). Information overload, psychological ill-being, and behavioral intention to continue online healthcare information search. *Computers in Human Behavior*, 70, 416-425. <https://doi.org/10.1016/j.chb.2016.12.068>
- Taylor, S. (2004). Understanding and treating health anxiety: A cognitive-behavioral approach. *Cognitive and Behavioral Practice*, 11(1), 112-123. [https://doi.org/10.1016/s1077-7229\(04\)80015-4](https://doi.org/10.1016/s1077-7229(04)80015-4)
- Tennant, B., Stelfox, M., Dodd, V., Chaney, B., Chaney, D., Paige, S., & Alber, J. (2015). EHealth literacy and Web 2.0 health information seeking behaviors among baby boomers and older adults. *Journal of Medical Internet Research*, 17(3), e70. <https://doi.org/10.2196/jmir.3992>
- Compaine, B. M. (2001). *The digital divide: Facing a crisis or creating a myth?* MIT Press.
- Gonzales, A. (2015). The contemporary US digital divide: From initial access to technology maintenance. *Information, Communication & Society*, 19(2), 234-248. <https://doi.org/10.1080/1369118x.2015.1050438>
- Mariën, I., & A. Prodnik, J. (2014). Digital inclusion and user (dis)empowerment: A critical perspective. *info*, 16(6), 35-47. <https://doi.org/10.1108/info-07-2014-0030>
- Friemel, T. N. (2014). The digital divide has grown old: Determinants of a digital divide among seniors. *New Media & Society*, 18(2), 313-331. <https://doi.org/10.1177/1461444814538648>
- Fergus, T. A., & Dolan, S. L. (2014). Problematic internet use and internet searches for medical information: The role of health anxiety. *Cyberpsychology, Behavior, and Social Networking*, 17(12), 761-765. <https://doi.org/10.1089/cyber.2014.0169>
- Hart, J., & Björgvinsson, T. (2010). Health anxiety and hypochondriasis: Description and treatment issues highlighted through a case illustration. *Bulletin of the Menninger Clinic*, 74(2), 122-140. <https://doi.org/10.1521/bumc.2010.74.2.122>
- Jokic-Begic, N., Lauri Korajlija, A., & Mikac, U. (2020). Cyberchondria in the age of COVID-19. *PLOS ONE*, 15(12), e0243704. <https://doi.org/10.1371/journal.pone.0243704>
- Jungmann, S. M., & Witthöft, M. (2020). Health anxiety, cyberchondria, and coping in the current COVID-19 pandemic: Which factors are related to coronavirus anxiety? *Journal of Anxiety Disorders*, 73, 102239. <https://doi.org/10.1016/j.janxdis.2020.102239>
- Muse, K., McManus, F., Leung, C., Meghreblian, B., & Williams, J. M. (2012). Cyberchondriasis: Fact or fiction? A preliminary examination of the relationship

- between health anxiety and searching for health information on the internet. *Journal of Anxiety Disorders*, 26(1), 189-196. <https://doi.org/10.1016/j.janxdis.2011.11.005>
- Te Poel, F., Baumgartner, S. E., Hartmann, T., & Tanis, M. (2016). The curious case of cyberchondria: A longitudinal study on the reciprocal relationship between health anxiety and online health information seeking. *Journal of Anxiety Disorders*, 43, 32-40. <https://doi.org/10.1016/j.janxdis.2016.07.009>
 - Starcevic, V., & Berle, D. (2013). Cyberchondria: Towards a better understanding of excessive health-related internet use. *Expert Review of Neurotherapeutics*, 13(2), 205-213. <https://doi.org/10.1586/ern.12.162>
 - Swar, B., Hameed, T., & Reychav, I. (2017). Information overload, psychological ill-being, and behavioral intention to continue online healthcare information search. *Computers in Human Behavior*, 70, 416-425. <https://doi.org/10.1016/j.chb.2016.12.068>
 - Sweller, J., Ayres, P., & Kalyuga, S. (2011). Cognitive load theory in perspective. *Cognitive Load Theory*, 237-242. https://doi.org/10.1007/978-1-4419-8126-4_18
 - Zhou, J., Arshad, S. Z., Luo, S., & Chen, F. (2017). Effects of uncertainty and cognitive load on user trust in predictive decision making. *Human-Computer Interaction – INTERACT 2017*, 23-39. https://doi.org/10.1007/978-3-319-68059-0_2
 - Laato, S., Islam, A. K., Islam, M. N., & Whelan, E. (2020). What drives unverified information sharing and cyberchondria during the COVID-19 pandemic? *European Journal of Information Systems*, 29(3), 288-305. <https://doi.org/10.1080/0960085x.2020.1770632>
 - Misra, S., & Stokols, D. (2011). Psychological and health outcomes of perceived information overload. *Environment and Behavior*, 44(6), 737-759. <https://doi.org/10.1177/0013916511404408>
 - Muse, K., McManus, F., Leung, C., Meghreblian, B., & Williams, J. M. (2012). Cyberchondriasis: Fact or fiction? A preliminary examination of the relationship between health anxiety and searching for health information on the internet. *Journal of Anxiety Disorders*, 26(1), 189-196. <https://doi.org/10.1016/j.janxdis.2011.11.005>
 - Samson, K., & Kostyszyn, P. (2015). Effects of cognitive load on trusting behavior – An experiment using the trust game. *PLOS ONE*, 10(5), e0127680. <https://doi.org/10.1371/journal.pone.0127680>
 - *Infodemic*. (2020, December 22). <https://www.who.int/health-topics/infodemic>
 - Jokic-Begic, N., Lauri Korajlija, A., & Mikac, U. (2020). Cyberchondria in the age of COVID-19. *PLOS ONE*, 15(12), e0243704. <https://doi.org/10.1371/journal.pone.0243704>
 - Kelley, K. J., & Gruber, E. M. (2010). Psychometric properties of the problematic internet use questionnaire. *Computers in Human Behavior*, 26(6), 1838-1845. <https://doi.org/10.1016/j.chb.2010.07.018>

- Koronczai, B., Urbán, R., Kökönyei, G., Paksi, B., Papp, K., Kun, B., Arnold, P., Kállai, J., & Demetrovics, Z. (2011). Confirmation of the three-factor model of problematic internet use on off-line adolescent and adult samples. *Cyberpsychology, Behavior, and Social Networking*, 14(11), 657-664.
<https://doi.org/10.1089/cyber.2010.0345>
- Misra, S., & Stokols, D. (2011). Psychological and health outcomes of perceived information overload. *Environment and Behavior*, 44(6), 737-759.
<https://doi.org/10.1177/0013916511404408>
- *THE INFLUENCE OF INFORMATION OVERLOAD AND PROBLEMATIC INTERNET USE ON ADULTS WELLBEING* [Unpublished doctoral dissertation]. (n.d.).
- 61% Indians Use Internet In 2021, Up From Just 21% In 2017 Says Report. (n.d.). *india times*.
- Kothari, M., & Parab, S. (2018). Increasing the reliability of health information on internet. *Indian Journal of Ophthalmology*, 66(2), 339.
https://doi.org/10.4103/ijo.ijo_916_17
- Abu Khait, A., Mrayyan, M. T., Al-Rjoub, S., Rababa, M., & Al-Rawashdeh, S. (2022).

Cyberchondria, anxiety sensitivity, hypochondria, and internet addiction: Implications for mental health professionals. *Current Psychology*. <https://doi.org/10.1007/s12144-022-03815-3>

- Burkauskas, J., Gecaite-Stonciene, J., Demetrovics, Z., Griffiths, M. D., & Király, O. (2022). Prevalence of problematic internet use during the coronavirus disease 2019 pandemic. *Current Opinion in Behavioral Sciences*, 46, 101179. <https://doi.org/10.1016/j.cobeha.2022.101179>
- Lai, C., & Tang, T. (2022). Information exposure and information overload as antecedents of crisis communicative responses and coping: A cross-country comparison. *American Behavioral Scientist*, 000276422211328. <https://doi.org/10.1177/00027642221132805>
- Nadeem, F., Malik, N., Atta, M., Ullah, I., Martinotti, G., Pettorruso, M., Vellante, F., Di Giannantonio, M., & De Berardis, D. (2022). Relationship between health-anxiety and Cyberchondria: Role of Metacognitive beliefs. *Journal of Clinical Medicine*, 11(9), 2590.

