

Review Article

Recent developments in damage detection of CFRP composites using non-destructive techniques – a review

Abstract

This paper presents a comprehensive overview of state-of-the-art nondestructive testing (NDT) methods specifically applied to carbon fiber reinforced polymer (CFRP) composites. The intent of this survey is to provide valuable guidance and insights to researchers and practitioners encompass in the arena of NDT for CFRP composites. Each NDT method is carefully examined, highlighting its principles, advantages, limitations, and potential applications in the evaluation of CFRP composite structures. The methods discussed in this paper include, but are not limited to, ultrasonic testing, eddy current testing, thermography, radiography, and acoustic emission. Furthermore, the information presented here aims to facilitate the selection and utilization of appropriate NDT methods for effective evaluation and quality assurance of CFRP composite structures along with challenges that researcher may encounter in the practical implementation of this techniques. Finally, an attempt is made to present alphabetically the review of literature on earliest to modern NDT methods published by various authors and how it continues to expand and become a viable technique for damage estimation.

Keywords: *Damage, CFRP, NDT, Structures, Sensors*

I. Introduction

The increasing utilization of CFRP composites in critical applications necessitates reliable and efficient methods for nondestructive evaluation. To ensure the structural integrity and performance of CFRP components, it is imperative to detect and characterize defects, such as

delamination, voids, fiber misalignment, and impact damage. Nondestructive testing (NDT) methods have emerged as indispensable tools for assessing the internal and surface conditions of CFRP composites. In this paper, we aim to summarize and analyze several prominent NDT methods for CFRP composites, exploring their benefits, limitations, and suitable applications. By providing a comprehensive overview of these techniques, we seek to facilitate further advancements in the field of NDT for CFRP composites. The deterioration can appear in composite structural components in several ways, at different times, and in different areas. The various types, stages, and places of defect affect the fatigue life of a composite structural component under a given load. Using a series of laboratory fatigue tests on identical specimens, it would be possible to predict the fatigue life of a composite structural component with a range of damage levels if the damage level is the primary determining factor. However, due to the varying effects of the types, amounts, and locations of damage, it is unreliable to predict the fatigue life of a specific structural component using simplified laboratory studies [1]. It is crucial to keep an eye on the location and level of damage (across all forms) to the structural component. Both the possibility of damage and the type of damage are affected by the materials. A structural substance is said to be "self-sensing" if it can sense itself. The real-time self-sensing of damage in carbon fibre polymer-matrix composites via electrical resistance measurement is explored [2]. Carbon fibre polymer-matrix composites are more vulnerable to lightning damage than metal-based constructions because they have a poorer electrical conductivity. Epoxy, when used in polymer-matrix structural composites, has a propensity to degrade in the presence of moisture. When heat and moisture are present, a hygrothermal condition, the degradation often gets worse. The thermal damage becomes serious when the temperature excursion occurs repeatedly. On the other hand, aluminum-based metal structures are prone to corrosion, creep, and plastic deformation. A component's dimensions are permanently changed through plastic deformation (yielding). In general, metallic, and composite structures are both vulnerable to damage. The occurrence of flaws like fibre waviness and delamination (local separation of the laminae, which refer to the fibre layers or plies) in a composite component even before its initial structural use, as well as the fact that the type and spatial distribution of flaws in a composite component can differ from piece to piece of the same component, even though the manufacturing process is the same for all the pieces, make it difficult to ensure the reliability of composites. Despite the small magnitude of the inherent flaws, they may serve as the catalyst for the emergence of more dangerous problems when the composite component is being used. Compared to composite ones, metal components frequently show less variance in quality. Therefore, it is not particularly reliable to predict the service life of a composite component based on the past performance of other, equivalent components. Because of this, composite structures have a higher need than metallic ones for structural health monitoring or damage detection.

II. Developments in detection of damages in composites

(i) **Assessment of Damage Detection in Composite Structures Using 3D Vibrometry:** The goal of structural health monitoring (SHM), which can help aircraft owners spot impact damage as it happens, is to continuously monitor a structure during its entire life. As a result, it may be fixed before it grows, saving weight and reducing the amount of time an aircraft needs to be

grounded. Acoustic Emission (AE) monitoring and Acousto-Ultrasonics (AU), both of which are based on knowledge of the propagation of ultrasonic waves, are two aspects of SHM that are being explored. In this work, authors [3] have understood how AU waves interact with delamination in carbon fibre reinforced polymers. 3D Scanning laser vibrometry is being used to track AU wave propagation. A PZT transducer was utilized to emit three frequencies, and a cross correlation approach was used to analyse the signal that was received. 100 kHz was observed to be the frequency that propagated the best of the three signals from this and the vibrometer scans. Then, a high-resolution scan was carried out at this frequency, revealing that only the wave's out-of-plane component, particularly the A0 mode, interacted with the damage. The most efficient frequency was determined to be 160 kHz through a 3D Fast Fourier Transform.

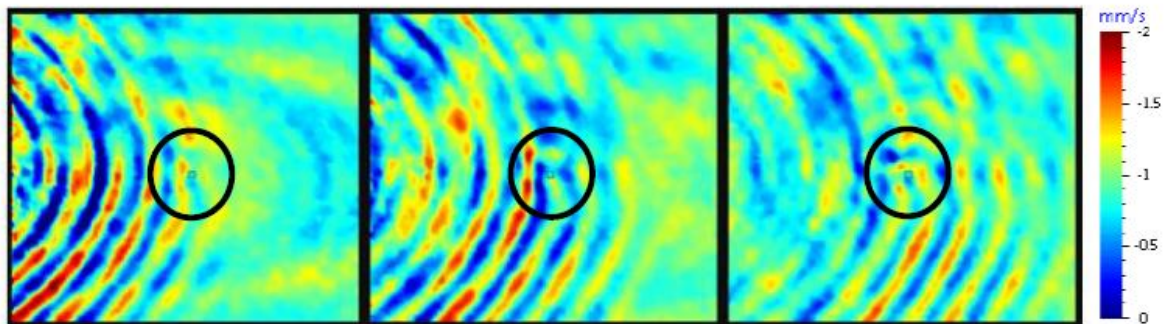

Figure 1. Interaction of the A0 mode with the damage from the high-resolution scan at 100 kHz with area of damage circled

(ii) Acoustic emission and infrared thermography: To determine the progression of deterioration in carbon fibre reinforced composites, acoustic emission (AE) and infrared thermography (IT) are simultaneously coupled. While tensile static stresses are applied to the samples, acoustic emission sensors and an infrared camera capture the acoustic signals and temperature changes, respectively. In order to extract damage mechanisms from acoustic signals, an unsupervised pattern recognition approach is used. In order to estimate global heat source fields from thermal measurements, thermodynamic considerations are presented [4]. A correlation range in the AE and IT event amplitude is determined by a geographic and temporal examination of acoustic events.

(iii) Bootstrap Method for Detecting Damage in CFRP: In order to identify delamination in carbon fibre reinforced plastic (CFRP), a new approach is devised in this article that reduces the confidence interval for changes in natural frequency. When compared to measurement errors, the variations in natural frequency in delaminated CFRP are negligible. The bootstrap approach, a statistical a technique to increase estimation accuracy from small samples, has been employed by authors [5] to find damage in CFRP. To test the effectiveness of the approach, using a macro fibre composite sensor, the natural frequency was assessed. The outcomes demonstrate that the bootstrap method enhances the confidence intervals of the natural frequency.

(iv) Capacitive Imaging of Impact Damage in Composite Material: This study [6] uses a coplanar capacitive sensor to demonstrate capacitive non-destructive imaging of impact damage in woven fibre CFRP. The approach is novel in that excitation frequencies for the best imaging

of delamination are first determined using the spectral features of the capacitive sensor response to CFRP properties. The best excitation frequencies for the studied samples were discovered to be greater than 200MHz. Each of the samples exhibited in figure 2 had delaminations that could be clearly seen by capacitive imaging. To establish the existence and size of the delaminations, phased array method was used to obtain ultrasonic (UT) C-Scans of hits. For imaging shallow faults in composite materials at depths where UT has insufficient time domain resolution, capacitive imaging techniques can be utilised as a complement to UT.

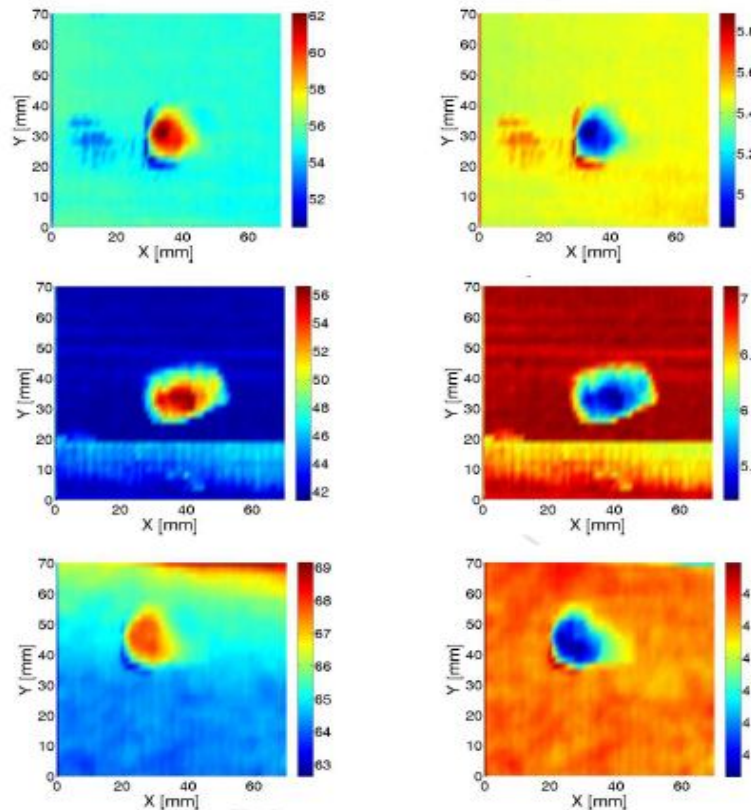

Figure 2. Capacitive images of delamination due to impact in the CFRP samples acquired at 300.04MHz, capacitance

(v) Damage detection of 3-D braided composite materials using carbon nanotube Thread:

For the strain detection of Structural Health Monitoring a 3D braided composite preform with carbon nanotube thread strain sensor was developed. The inquiry by authors [7] into a network of carbon nanotube threads placed in 3D composites for the purpose of detecting damage yielded data on changes in the electrical resistance of the carbon nanotube threads. The response surface method was used to estimate the location and magnitude of damages in the 3D composites

shown in figure 3 based on changes in electrical resistance. This method provided an efficient way to estimate the location and number of damages.

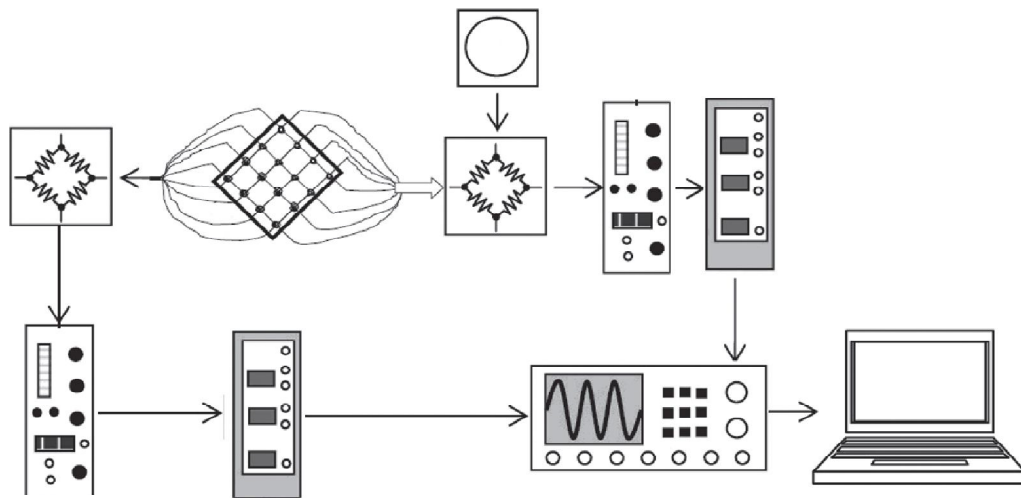
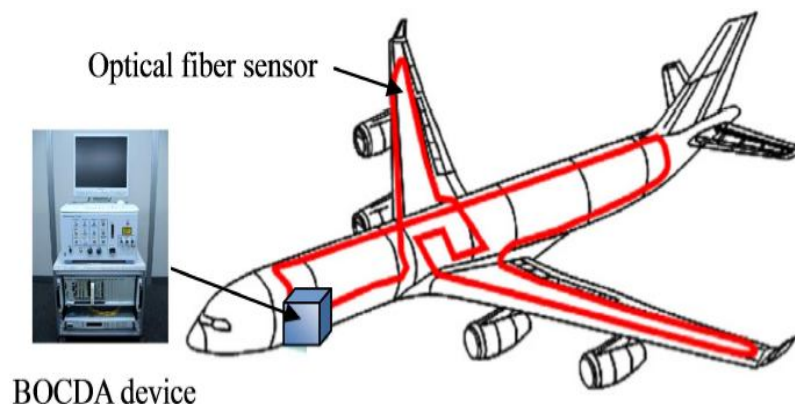

Figure 3: Schematic illustration of the experimental setup for dynamic measurements.

vi) DIC method: Authors [8] reported on the use of full-field digital image correlation (DIC) for UD CFRP component damage detection. The effects of fake imperfections on vibration modes were examined using stereo-DIC data. Finally, the impact of the faults was analysed, as well as the effectiveness of the DIC approach.

vii) Distributed BOCDA Optical Fiber Sensor: One of the distributed optical sensing methods that makes use of the Brillouin scattering phenomenon is Brillouin optical correlation domain analysis (BOCDA). The BOCDA monitoring capability for composite damages, such as debonding at adhesive connections and micro-damages at bolted joints, as seen in figure 4, is described in this study [9] in terms of its current state of development.



Due to its strength Figure 4. Application concept of BOCDA-SHM Technology frequently utilised in the construction of aeroplanes like the Boeing 787 and Airbus A380. Still used in primary constructions are bolted joints. Bearing failure is the primary failure mode for bolted joints. Because CFRP are brittle materials with limited yielding, stress concentrations that occur close to bolted joints are not eased by plastic deformation, bearing failures may result in catastrophic failures. Bolted joints are crucial inspection parts as a result. Inspection times will

be shortened if it is possible to inspect damage at bolted joints without removing fittings. Adhesive joints are mostly used in secondary structures since they are susceptible to abrupt breakdowns due to problems with manufacturing quality control. Adhesive joints of CFRP components will be used more frequently in aeroplane structures if it can identify the beginning and progression of these failures. Debonding detection tests and bearing damage detection tests were therefore carried out in order to increase the monitoring ability for these damages in composite structures using the BOCDA, as illustrated in Fig. 4. BOCDA distributed strain measurement was used to find debonding at stiffened or repaired panels. Brillouin gain spectrums (BGS), one of the BOCDA measurement outcomes, with an embedded optical fibre sensor, were used to identify bearing defects at bolted joints.

(viii) Damage Detection based on the Natural Frequency shifting: In a failure analysis, damage detection of any structure becomes the primary concern. Early failure detection is crucial because it can stop any catastrophic failure by quickly replacing or fixing the damaged component. Frequency-based vibration analysis is one of the non-destructive techniques for damage identification. The primary focus of this research [10] is the identification and comparison of a set of natural frequencies before and after damage. An original, undamaged structure was represented by a rectangular plate of CFRP that was clamped at all edges. According to Kachanov's concept, the presence of some circular voids signals the occurrence of damage in a structure. The levels of damage for the voids are generated at random. A clamped plate Finite Element Model (FEM) is examined to get the Natural Frequencies using the most recent Young's Modulus value. The Natural Frequencies are discovered to shift when the void existence increases based on the results of the FEM research. The model of Natural Frequency shifting as a function of damage evolution has been created using curve fitting. The bigger absolute gradient indicates that the shifting of the Natural Frequency is greater at higher frequency values.

(ix) Eddy current pulsed thermography: With the benefits of contactless, simple detecting, and effective heating, this method is well known for nondestructive testing of electrically conductive materials. It is possible to use the idea of divergence characterisation of the damage rate of CFRP-steel structures to ECPT thermal pattern characterization. According to this study's findings [11], the use of ECPT technology to CFRP-steel constructions produced a sizable amount of useful data for thorough material diagnostics. Using mathematical models to examine data on the orientations, gaps, and undulations that resemble the texture of fibres in these multilayered materials would enable the identification and analysis of the relationship between divergence and transient heat patterns. The developed algorithm enabled to extract damage features and remove information about fibre texture. Using COMSOL Multiphysics® software, a model of the damaged CFRP-glue-steel constructions was created, and quantitative non-destructive damage evaluation was produced from the areas of the ECPT image. The outcomes of this suggested procedure demonstrate how the knowledge of the texture of the fibre has a significant impact on damaged areas. The proposed research can be used to assess CFRP structures quantitatively and for the identification of impact-induced damage.

(x) Electrical Resistance Mapping: In this study authors [12] reported on a new technique for assessing degradation in carbon fiber/polypropylene composites by mapping electrical resistance in two dimensions. Due to their electrical conductivity, carbon fibres are utilised as sensing components in CFRP. In such investigations, the fundamental hypothesis was that electrical resistance (ER) measurement might be used to identify carbon fibre movement. In this study, carbon fiber/polypropylene/polyamide (CF/PP-PA) composites were examined for their prospective usage in thermoplastic automotive applications. To detect and forecast defects, two-dimensional electrical resistance (2D ER) mapping was employed. Using 2D ER mapping contour charts, the degree of random dispersion of carbon fibres (CF) in the PP-PA matrix was assessed. The evaluation of dispersion and micro-damages was conducted using ER data gathered at nine different places. For comparison, the homogeneity of CF dispersion on cracked surfaces was seen. The amount of CF in each part was determined using pyrolyzed tissues, and the results were compared to 2D ER mapping. To investigate their potential for use in real-time monitoring and damage sensing, the differences in ER for tensile and compressive stresses were investigated. The observed cracked surfaces showed a respectable concordance with the 2D ER findings. In the end, 2D ER mapping proved helpful in assessing and foretelling damages in Carbon Fiber/Poly Propylene composites under different loading circumstances.

(xi) Elliptical Method of damage detection: In this study, it is suggested that the elliptical plane modal identification method be employed as a damage identification method in and of itself. The area of the ellipse generated close to the resonant frequencies (which depends on the modal constants) is utilised to identify damage, specifically to composite carbon fibre reinforced polymer (CFRP) rectangular plates, according to authors [13]. Results indicate that the approach is sensitive to the presence of damage in the test plates, as the area of the ellipse changes with damage, even though a mathematical correlation has not yet been established. It was established that damage consistently affects the ellipse's area, which is connected to the modal constants (local modal characteristics). Because the elliptical plane modal identification method yields encouraging findings for damage identification in CFRP rectangular plates, this article opens up new opportunities for other researchers who are interested in damage diagnosis in lightly damped structures.

(xii) Fiber Bragg Grating Sensors: Based on an analysis of the relationship between changes in the strain distribution and damage expansion of CFRP laminated plates and the strain information shown in figure 5, the damage recognition method of CFRP laminated plates is proposed in this study [14]. The accuracy of the CFRP laminate damage detection method is next verified by performing the CFRP laminate damage identification experiment based on FBG sensor. Next, a Fibre Bragg Grating (FBG) sensor-based CFRP laminate damage monitoring system is developed. The results reveal that the difference between the load at which a damage appears on the FBG sensor and the load at which a damage to CFRP laminated plates expands in accordance with the simulated analysis is, at most, 16%. CFRP laminated plates' expansion process and damage recognition are both completed, and the efficacy of the damage recognition method for CFRP laminated plates is validated.

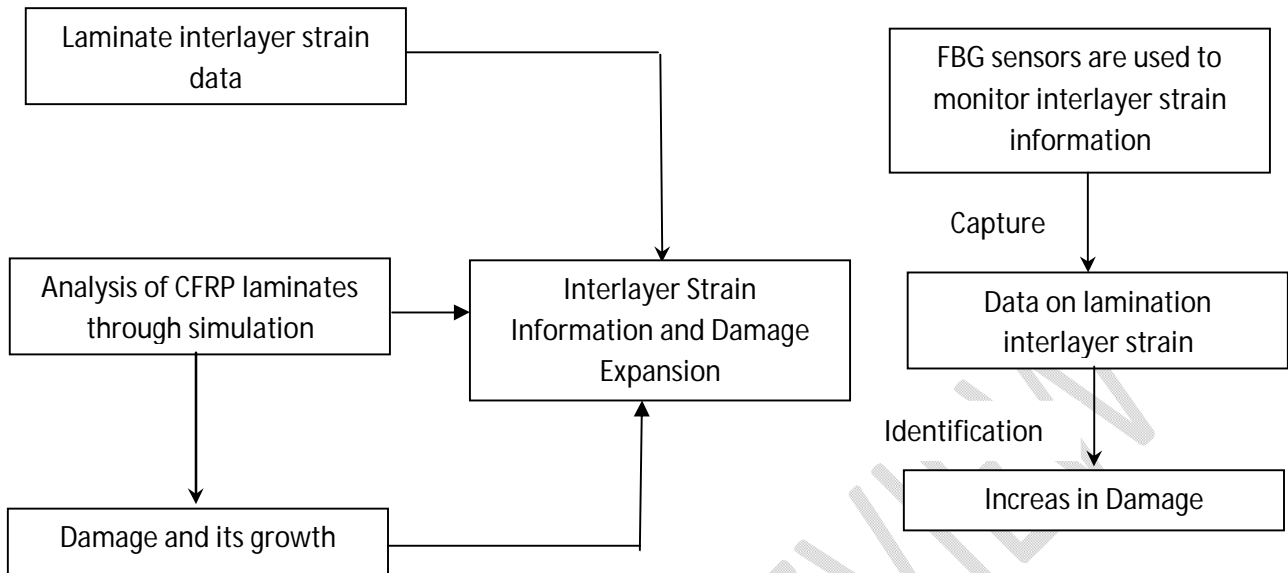

Figure 5. Damage recognition theory based on FBG Sensor for CFRP laminated plates

(xiii) Free-space microwave non-destructive techniques: A pair of common gain horn antennas encompassing the frequency range of 26.5 GHz to 40 GHz have been used in an investigation of a free-space microwave approach for non-destructive testing of unidirectional CFRPs [15]. The simulations link the fluctuations of the measured scattering parameters S_{ij} to the experimental findings concerning the existence and severity of the analysed faults. The method is based on a comparison between the electromagnetic signal that a healthy sheet material is able to reflect and transmit when a radio frequency (RF) wave is incident on it, and the electromagnetic signal that a damaged sheet is able to reflect and transmit. By measuring the difference between the two transmitted waveforms, the defect's potential existence can be determined. The effectiveness of this radio wave methodology is examined in connection to surface flaws as well as in relation to flaws that are harder to spot using this technique, like delaminations, cavities, and inclusions. The finite element method (FEM) and the finite integration technique (FIT) are both used in the simulations.

(xiv) Multimodal Damage Detection in Self-Sensing Fiber Reinforced Composites: Fibre reinforced polymer composite materials with functional elements have internal delamination damage. A vascular system that delivers fluids that precipitate magnetic particles upon mixing is used to achieve damage-triggered magnetization of the delaminated zone in figure 6. This magnetic substance is detected using a variety of detecting methods. By creating a biomimetic "bruise" with the magnetic particles that contrasts sharply between damaged and unharmed areas, visual detection is made possible. Even if the particles are covered in paint or opaque reinforcement, like carbon fibre, magnetic scanning can still find them. Inductive heating of the magnetic particles and infrared camera detection of the temperature difference are other methods for thermal detection. To determine accuracy, the efficacy of each detection mechanism is described [16] and contrasted with the accepted C-scan method. Visual detection measures the

damage area with a 76% accuracy, while magnetic detection measures it with a 91% accuracy, using the C-scan damage area as a baseline. Accuracy of thermal detection is time-dependent, as anticipated. Consistently, damage is found using every detecting method. The versatility of this material enables damage detection methods to be customised for the application and offers a parallel system to support and possibly improve self-healing.

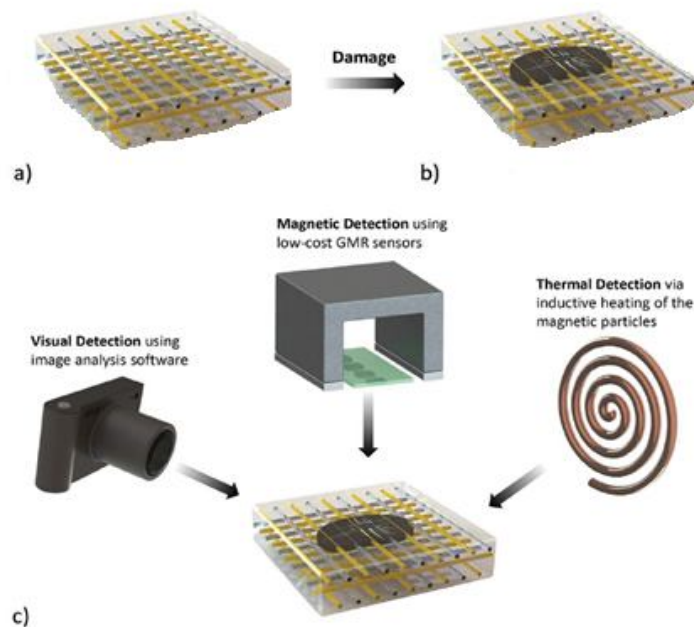

Figure 6. a) Schematic of the active vascular material system used to deliver the liquid constitutive parts of the magnetic particles. b) Mixing of the liquids causing precipitation of magnetic material in the damaged region. c) Schematic of three modes of damage detection: visual, magnetic, and thermal. Each mode is possible because of the high contrast between damaged and undamaged areas provided by the magnetic particles.

(xv) Phased Array Nondestructive Ultrasonic Inspection of Composite Materials: Due to their exceptional strength-to-weight ratio and resistance to corrosion, carbon- and glass-fiber reinforced polymer (CFRP and GFRP) composite materials have found employment in a variety of industries, including the automotive and aerospace sectors. For safe functioning, these materials' quality is crucial. Techniques for nondestructive testing (NDT) are a useful way to examine these composites. Although conventional ultrasonic NDT, utilising single element transducers, has disadvantages including high attenuation and low signal-to-noise ratio (SNR), it has been utilised in the past to inspect composite materials. Signals can be produced at appropriate angles and distances using the phased array ultrasonic testing (PAUT) procedures depicted in figure -7. For composites, where the anisotropic nature makes signal assessment difficult, these capabilities offer encouraging results. Detection of flaws in composites based on bulk and directed waves was reported by [17]. By comparing the signal characteristics to the traditional technique, the PAUT's potential and susceptibility to errors were assessed. According to the findings, PAUT can detect flaws with a size as tiny as 0.8 mm and a penetration depth of up to 25 mm, and the result signals exhibit better properties than those produced by traditional

ultrasonic technology. Additionally, it has been demonstrated that guided waves produced by PAUT have a remarkable capacity for finding flaws in composite materials.

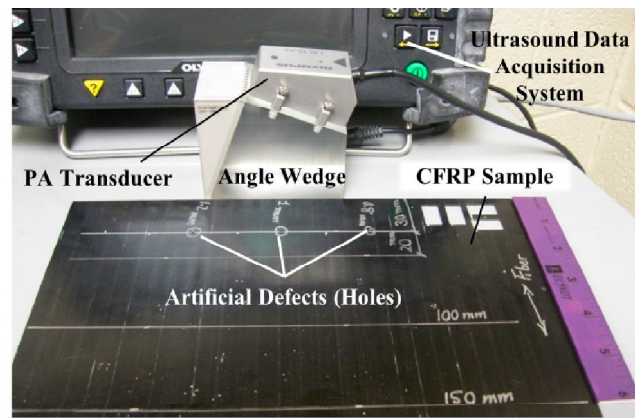

Figure 7. Experimental setup for flaw detection in CFRP sample using PAUT guided wave method

(xvi) ReliefF and LSSVM Method: For the prompt identification of structurally invisible damage and the prevention of catastrophic effects, the damage identification method of carbon fibre reinforced polymer structures is of major significance. [18] reported on a technique for identifying damage in composite materials based on ReliefF and LSSVM (Least Squares Support Vector Machine). First, using the non-damage active excitation approach, the damage signals of the composite structure were obtained. The damage feature is then extracted, and the ReliefF feature dimension is decreased, using the Fourier transform. The damage feature was used as input and the damage mode as an output to create the damage identification model based on LSSVM. According to the experimental findings, the proper recognition time for the 20 tests was 19 times, indicating a better degree of damage identification accuracy. This paper offers a workable technique for identifying damage in composite constructions. ReliefF is a feature weight algorithm that removes the feature selection and assigns various weights based on the correlation of each feature. This feature selection algorithm performs really well.

(xvii) Self-Sensing Curved Micro-Strip Line Method: The current study employs a self-sensing Time Domain Reflectometry (TDR) technique for CFRP laminate damage detection, which has been supported by [19]. In a gearbox line, carbon fibre sensors are used. Several research articles have been written about the self-sensing TDR technology. The self-sensing TDR technique reduces the amount of electrodes required to detect damage while sacrificing detection sensitivity. Using the micro-strip line (MSL) method to obtain impedance matching with a coaxial cable, damage to a CFRP laminate was successfully found in the earlier examination. In the current investigation, an impedance-matched transmission line for the larger region shown in figure 8 is experimentally tested as a long, curved MSL to identify damage to a CFRP laminate. Fibre breaking is simulated by drilling a hole. Since a CFRP laminate has a substantially orthotropic electric conductance and the electric properties of a CFRP laminate at

the high frequency are unknown, the impact of the orthotropic conductance at the bent gearbox line is experimentally examined

As a result, it is shown that orthotropic conductance at the curved strip line has no bearing and that the self-sensing curved MSL approach may identify fibre breakage that takes place close to the copper strip line.

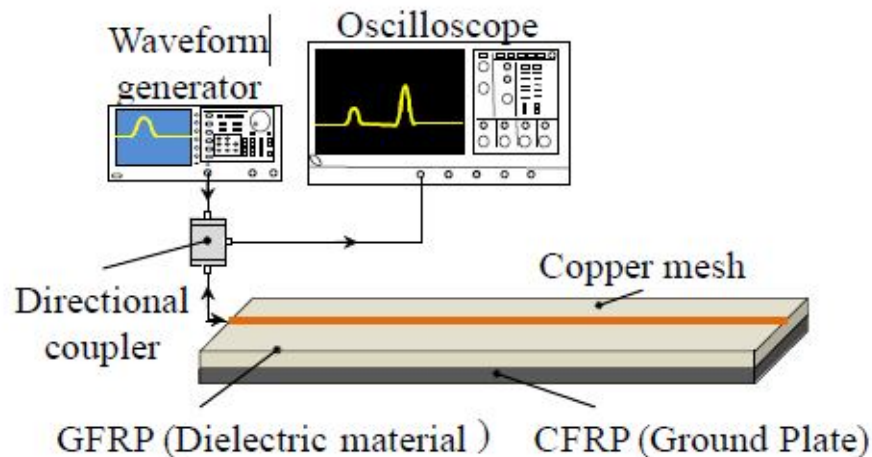

Figure 8. Schematic representation of self-sensing TDR method for damage detection of a CFRP laminate.

(xviii) Supramolecular approach: It has been reported that the introduction of a CB8-based ternary complex as an additive utilising a supramolecular technique enabled self-diagnosis of early-stage damage in a carbon fibre epoxy composite material [20]. The CB8-encapsulated complex, which consists of a fluorescent probe and a quencher, is added to the epoxy resin of the composite as a supramolecular crosslinking agent, causing its stress-induced dissociation to activate the probe's fluorescence. This makes it possible to identify irreversible mechanical strain and fatigue at an early stage, allowing for the evaluation of microdamage in the material depicted in figure -9.

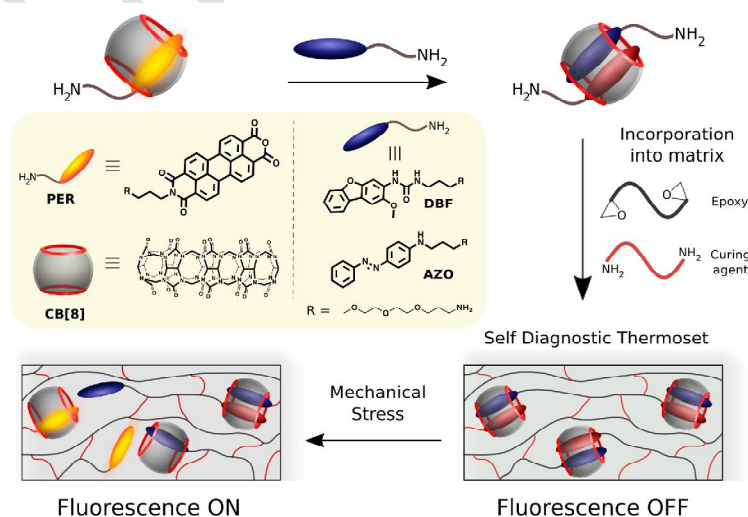

Figure 9. Schematic representation of the working principle and components of the damage reporting carbon fiber-epoxy resin composites

(xix) Ultrasound and electromagnetic method of detecting damage in CFRP composites:

The behaviour of carbon fibre woven-PPS composites at low velocity impacts is discussed by the authors [21] in this study. Since the plastic deformation after impacts changes the transversal electrical conductivity, electromagnetic procedures (figure 10a) can be used to evaluate CFRP using a high-resolution sensor with a metamaterials lens and compare the results to those from ultrasound testing with a phased array sensor. When phased array ultrasound is utilised (figure 10b), the area of the delamination is overstated, but electromagnetic testing significantly underestimates it. The finite element simulations and the experimental data were found to be in good agreement.

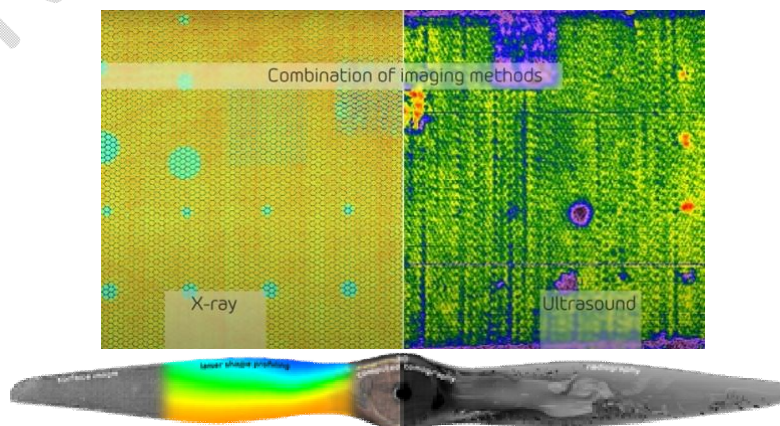

Figure 10.a - Electromagnetic testing



Figure 10.b - Ultrasound Testing

(xx) X-ray combined with Ultrasound for damage detection in CFRP: Radalytica [22] created a multimodal inspection method that combines ultrasonic testing (UT) and x-rays for the purpose of identifying impact damage to composite materials. Because delamination may be very accurately identified by ultrasound but cannot be detected by x-ray. If there are cracks in impact damage, high-resolution x-ray imaging gives a lot of information, but it is impossible to discern any surrounding delamination. However, with ultrasonography, only the delamination may be seen, not the entire impact. The current idea is to combine these two methods to give a far better overall picture of damage identification in composites.



III. Conclusions:

In order to give a thorough analysis of composite NDT, this research analysed many contemporary NDT techniques for evaluating damage detection in CFRP composites by classifying their advantages and disadvantages, as indicated in table 1. When it comes to load-bearing composite materials used in high-performance applications, the capacity to identify early deterioration is extremely important. Non-destructive testing of carbon fibre composite materials has grown more important and demanding as a result of the fact that carbon composites are mostly utilised in essential safety applications, such as the primary construction of aviation, automobile, marine, and transportation, etc. The optimum approach should be chosen after taking efficiency and safety into account. Additionally, the strategy picked ought to lower the expense of the process. It is based on techniques that employ physical quantities to ascertain the qualities of materials. Additionally, contemporary non-destructive tests [23 – 30] use physical concepts to identify and assess faults or destructive defects.

Table 1 – Advantages and Disadvantages of various NDT methods [31]

Sl. No.	NDT Techniques	Advantages	Disadvantages
1.	3D Vibrometry	<ul style="list-style-type: none"> For a better knowledge of the delamination in FRP Composites, 3D scanning laser vibrometry is applied. Only the out of plane wave component will interact with the damage, according to a high-resolution scan. 	<ul style="list-style-type: none"> Damages in the X-Y plane can be successfully found. Delamination or damage in the Z-plane, however, is challenging to accomplish yet produces encouraging results
2.	Ultrasonic Test Method	<ul style="list-style-type: none"> Capability of use in field testing Good resolution and flaw detecting capabilities and speed of scan. 	<ul style="list-style-type: none"> The difficulty of setup; the expertise required to accurately scan a part Requirement for a test sample to ensure accurate testing.
3.	Thermographic Testing	<ul style="list-style-type: none"> It may examine a part's large surface. The second benefit is that it does not require coupling, in contrast to many other methods of examination. This makes it possible to inspect parts that can only be inspected from one side. 	<ul style="list-style-type: none"> Need for sensitive, costly equipment Requirement for highly qualified inspectors to operate the equipment Lack of clarity of faults if they are too deeply embedded beneath the surface of the part.

4	Radiographic Testing	<ul style="list-style-type: none"> • Effective in locating significant voids, inclusions, trans-laminar cracks, uneven distribution of fibres, and fibre misorientation like wrinkles. 	<ul style="list-style-type: none"> • With this technique, delamination can only be noticed if its orientation is not parallel to the x-ray beam.
5.	Acoustic Emission	<ul style="list-style-type: none"> • It is a useful technique for analysing flaws. This mechanical vibration is caused by material flaws such fibre pullout and breakage, localised delamination, fiber-matrix debonding, and matrix microcracking. • It is particularly helpful in identifying numerous types brought on by fatigue loading. 	<ul style="list-style-type: none"> • Correlating acoustic emission data to certain categories of damage mechanisms demands a high level of expertise.
6.	Acousto-Ultrasonic	<ul style="list-style-type: none"> • This approach combines acoustic and ultrasonic testing and is used to assess the degree of internal flaws and inhomogeneity in composite materials. • Based on ideal economics, flexibility, and sensitivity, the acoustic/ultrasonic class of testing in nondestructive testing has considerable potential. 	<ul style="list-style-type: none"> • Pre-calculations and setup are required before any testing. • This form of testing is ineffective for identifying specific, significant faults like delamination or voids.
7.	Shearography Testing	<ul style="list-style-type: none"> • Shearography has the benefit that the failure of composite materials typically results from stress concentrations, and the degree of strain concentrations surrounding a specific defect makes determining the criticality of defects simple. • Compared to many other methods of non-destructive testing, it is less vulnerable to noise. This is advantageous since it enables less experienced users to examine and assess a part's suitability without requiring substantial training. 	<ul style="list-style-type: none"> • Shearography has a significant drawback in that it is very difficult to characterise defect forms other than delamination.
8.	Boot Strap Method	<ul style="list-style-type: none"> • In order to assess the effectiveness of the technology, the natural frequency is measured using a macro fibre composite sensor. • This statistical technique improves the estimation accuracy from small samples for identifying damage in CFRP. 	<ul style="list-style-type: none"> • The approach is just for minor constructions
9.	Capacitive Imaging	<ul style="list-style-type: none"> • Subsurface flaws and delamination are easily detectable 	<ul style="list-style-type: none"> • Due to their inhomogeneous and anisotropic nature, FRP composites present a

			highly difficult evaluation of damage over the skin depth.
--	--	--	--

10.	Micro-Strip Line Method	<ul style="list-style-type: none"> By using this technique, damage to a CFRP laminate was successfully detected and impedance matching with a coaxial cable was obtained. 	<ul style="list-style-type: none"> When the damage is distant from the strip line, it is difficult to find it.
11.	ReliefF and LSSVM method	<ul style="list-style-type: none"> ReliefF and LSSVM can be used to identify damage in composite materials in a practical and efficient manner 	<ul style="list-style-type: none"> A vast number of sampling points are necessary for a method to be reliable.

References

[1]	Wolterman, R. L., Kennedy, J. M., and Farley, G. L. "Fatigue damage in thick, cross-ply laminates with a center hole". ASTM Spec. Tech. Publ., STP 1156, Composite Materials. Fatigue and Fracture, 1993, 4, 473–490.
[2]	D D L Chung "Damage detection using self-sensing concepts" Proceedings of IMechE Vol 221, Part G: Journal of Aerospace Engineering, 2007, 509 -520.
[3]	S Grigg, M Pearson, R Marks, C Featherston and R Pullin, "Assessment of Damage Detection in Composite Structures Using 3D Vibrometry", 11th International Conference on Damage Assessment of Structures (DAMAS 2015), Journal of Physics: Conference Series 628, 2015
[4]	V. Munoz, B. Vales, M. Perrin, M.L. Pastor, H. Weleman, A. Cantarel, M. Karama, "Damage detection in CFRP by coupling acoustic emission and infrared thermography" Composites Part B, July 2015, page 1 – 25.
[5]	Alradix Djansena, Hiroaki Tanaka, Akira Kudo, "Bootstrap Method for Detecting Damage in Carbon Fiber Reinforced Plastic Using a Macro Fiber Composite Sensor", National Defense Academy, Japan, Vol. 55, No. 1, 2015, pp. 1-11
[6]	Maxim Morozov, William Jackson, S.G. Pierce, "Capacitive imaging of impact damage in composite material", Composites Part B Engineering, Vol. No. 113, 2017 page 1 – 20.
[7]	Zhenkai Wan*, Jianmin Guo and Minrui Jia, "Damage detection of three-dimensional braided composite materials using carbon nanotube thread", Science, Engineering Composite Materials, 2015
[8]	K.N. Antin L. Harhanen S. Bossuyt "Damage Detection in CFRP Components Using DIC" The Society for Experimental Mechanics, Inc. 2016, 57 – 62
[9]	Nozomi Saito, Takashi Yari1, Kanehiro Nagai and Kiyoshi Enomoto, "Development of the Damage Detection Method for CFRP Structures Using Distributed BOCDA Optical Fiber Sensor" Key Engineering Materials, 2013, Vol. 558, pp 218-226
[10]	Irfan Hilmy, MM. Abdel Wahab, Erry Yullian T. Adesta, Tasnim Firdaus, "Damage Detection based on the Natural Frequency shifting of a clamped rectangular plate model"

	Journal of Physics: Conference Series, 628, 2015, Page 1 – 6.
[11]	Xuan Lia, Zhiping Liua, Xiaoli Jiangb and Gabrol Lodewijksb, “Method for detecting damage in carbon-fibre reinforced plastic-steel structures based on eddy current pulsed Thermography”, <i>Nondestructive Testing and Evaluation</i> , 2018 Vol . 33, No. 1, 1–19

[12]	Park Joung-Man, Dong-Jun Kwon ¹ , Pyeong-Su Shin, Jong-Hyun Kim ¹ and Lawrence K DeVries, Gyeongsang, “New sensing method of damage detection of carbon fiber/polypropylene composites via 2 dimensional electrical resistance mapping”, 13 th International conference on “Nanotek & Expo”, December 05 – 07, 2016, USA, <i>Journal of Nanomedicine & Nanotechnology</i> , 2016.
[13]	D M Amafabia, Diogo Montalvão, Opukuro David-West and George Haritos “Elliptical Method for Damage Identification in Carbon Fibre Reinforced Polymer Laminates” <i>Advances in Materials Science and Engineering</i> , Volume 2019, Pages 1– 8.
[14]	Guoping Ding, Wenhao Song, Xiaoling Gao and Hao Cao “Damage Detection in Holed Carbon Fiber Composite Laminates Using Embedded Fiber Bragg Grating Sensors Based on Strain Information”, <i>Shock and Vibration</i> , Volume 2020, Pages 1– 11.
[15]	Daniela Munalli, Georgios Dimitrakis, Dimitrios Chronopoulos, Steve Greedy, and Andrew Long, “The use of free-space microwave non-destructive techniques: simulation of damage detection in carbon fibre reinforced composites”. 11 th International Symposium NDT in Aerospace, September 2019
[16]	Matthew D. Crall, Samuel G. Laney, and Michael W. Keller, “Multimodal Damage Detection in Self-Sensing Fiber Reinforced Composites”, <i>Advanced Functional Materials</i> , 2019, Page 1- 8.
[17]	Hossein Taheri, and Ahmed Arabi Hassen, “Nondestructive Ultrasonic Inspection of Composite Materials: A Comparative Advantage of Phased Array Ultrasonic” <i>Applied Sciences</i> , 2019, vol 9, page 2 – 16
[18]	Shizeng Lu, Hongliang Yu, Rongfeng Zhang, Xiaohong Wang, “Damage identification method of Carbon fiber reinforced polymer structure based on ReliefF and LSSVM”, The 30 th Chinese Control and Decision Conference, 2018, page 6257 – 5261
[19]	Akira Todoroki ¹ , Kazuhiro Yamada, Yoshihiro Mizutani ¹ , Yoshiro Suzuki, Ryosuke Matsuzaki, Hiroyasu Fujita, “Self-Sensing Curved Micro-Strip Line Method for Damage Detection of CFRP Composites”, <i>Open Journal of Composite Materials</i> , 2014, Vol. 4, Page 131-139
[20]	Anjali Devi Das, Giulia Mannoni, Andreas E. Fruh, Davide Orsi, Roberta Pinalli, and Enrico Dalcanale, “Damage-Reporting Carbon Fiber Epoxy Composites” <i>ACS Applied Polymer Materials</i> , 2019, 1, 2990–2997
[21]	A Savin, P D Barsanescu, P Vizureanu, M D Stanciu, I Curtu, N Iftimie, R Steigmann “Damage detection of carbon reinforced composites using nondestructive evaluation with ultrasound and electromagnetic methods”, <i>Materials Science and Engineering</i> , vol 133 2016, page 1 – 5
[22]	https://www.compositesworld.com/articles/robotic-computed-tomography-removing-ndt-barriers-for-composites
[23]	Alarifi, I. M., Movva, V., Rahimi-Gorji, M., and Asmatulu, R. (2019). Performance analysis of impact-damaged laminate composite structures for quality assurance. <i>Journal of Brazilian. Society of Mechanical Sciences Eng.</i> 41 (8), 27–34. doi:10.1007/s40430-019-

	1841-5
[24]	Antin, K.-N., Machado, M. A., Santos, T. G., and Vilaça, P. (2019). Evaluation of different non-destructive testing methods to detect imperfections in unidirectional carbon fiber composite ropes. <i>J. Nondestr. Eval.</i> 38 (1), 23–12. doi:10.1007/s10921-019-0564

[25]	Asokkumar, A., Jasiūnienė, E., Raišutis, R., and Kažys, R. J. (2021). Comparison of ultrasonic non-contact air-coupled techniques for characterization of impact-type defects in pultruded gfrp composites. <i>Materials</i> 14 (5), 1058. doi:10.3390/ma14051058
[26]	Bahonar, M., and Safizadeh, M. S. (2022). Investigation of real delamination detection in composite structure using air-coupled ultrasonic testing. <i>Compos. Struct.</i> 280, 114939. doi:10.1016/j.composite structures.2021.114939
[27]	Bang, H.-T., Park, S., and Jeon, H. (2020). Defect identification in composite materials via thermography and deep learning techniques. <i>Compos. Struct.</i> 246, 112405. doi:10.1016/j.composite structures.2020.112405
[28]	Ellison, A., and Kim, H. (2020). Shadowed delamination area estimation in ultrasonic C-scans of impacted composites validated by X-ray CT. <i>J. Compos. Mater.</i> 54 (4), 549–561. doi:10.1177/0021998319865311
[29]	Gao, T., Wang, Y., and Qing, X. (2021). A new laser ultrasonic inspection method for the detection of multiple delamination defects. <i>Materials</i> 14 (9), 2424. doi:10.3390/ma14092424
[30]	Han, D.-H., and Kang, L.-H. (2018). Nondestructive evaluation of GFRP composite including multi-delamination using THz spectroscopy and imaging. <i>Compos. Struct.</i> 185, 161–175. doi:10.1016/j.compstruct.2017.11.012
[31]	S. Gholizadeh “A review of non-destructive testing methods of composite materials”, XV Portuguese Conference on Fracture, Procedia Structural Integrity 1 (2016) 050–057

Acknowledgments

Authors would like to thankfully acknowledge Principal, Management and Heads of the Department of Mechanical Engineering and Industrial Engineering & Management for their constant and encouragement extended during this work.

Funding

We also thankfully acknowledge AICTE, New Delhi for funding this project work under Research Promotion Scheme Grant No. File No. 8-26/FDC/RPS (POLICY-1) /2019 – 20.