

Original Research Article

IMPLEMENTATION OF A MICROCONTROLLER BASED MULTIPLE SOURCE POWER SUPPLY SELECTOR WITH PRIORITY OPTION

Abstract

Increasing global use of technology in everyday chores has raised the need for electric power in our lives. The need for constant power thereby becomes very paramount for the smooth running of modern systems. In Nigeria incessant outages have led to failures in systems and sometimes lives, necessitating the use of multiple sources of power for homes, offices and industries, each of which costs differently to use. This work presents the design and implementation of a microcontroller based multiple source power selector with priority selector. The inclusion of priority selection means each source can be selected for use based on its cost or un-interruptibility. When cost is prioritized by selection then mains power is first selected for use before generator, and when both are absent then solar is optionally available for selection. When uninterruptible power (UP) is prioritized then the source with better quality is selected for use. The three sources are each stepped down using a transformer, rectified and sampled to an ATmega328 microcontroller which is programmed to select the most appropriate output based on the Cost or availability. The system was simulated in Proteus simulation environment, Simulation result show that in all cases of performance the source that is supplied to the output is based on the priority mode selected. This system can be used in economy mode for homes where cost of power is the criteria while in hospitals the UP-priority mode is recommended because availability is what matters. In conclusion the device reduced the possibility of power being off completely in case of power failure in any particular source if users connect their electronics gadget to it and reduced the response time needed to switch from one source to another.

Comment [pa1]: incomplete abstract, in the abstract complete with purpose, materials and methods, results and conclusions

Key word: Uninterruptible power, Simulation, Priority, Microcontroller, Graphic User interface, Outages

Introduction

Power supply in Nigeria and most developing countries of the world is anything but stable. This has adverse effects on the consumers of the electricity and the equipment that are operated from the mains sources of electricity supply in these parts of the world. Power instability and phase failure has posed serious threat to their economic development (khairul, *et al.*, 2014). This means where there is an erratic power supply, there is no development. However, most companies; Industrial, commercial and even domestic are dependent on public power supply which have erratic supply such as phase failure, phase imbalances or total power failure due to one or more technical problem in power generation, transmission or distribution (Adedokun, & Osun pidan., 2010). Hence, there is need for automation of phase change during phase failure or total power failure in order to safe guard consumer appliances from epileptic power supply.

In most cases, many manufacturing companies, be it domestic or industrial, which employ single phase equipment for its operation, sometimes experience challenges during unbalance voltages, overloads and under-voltages, in power supply, much time would be required in the process of manual change over. This means that time and the process needed for the phase change may cause serious damages to machines and even the products, hence, there is need for automatic phase switching system. Considering also a case where a single-phase public utility prepaid meter is operated with a single-phase power supply unit and there is phase failure from the public utility power supply, the prepaid meter will stop reading. At this point, if the phase is not manually changed, the single-phase prepaid meter will stop reading. That is to say someone needs to be present always to make the changes at any point in time. But to overcome these protocols, automatic systems need to be used.

Method of Design

In actualizing this system, the block diagram of figure 1 and 2 was employed as a guide for the calculation and or selection of components values.

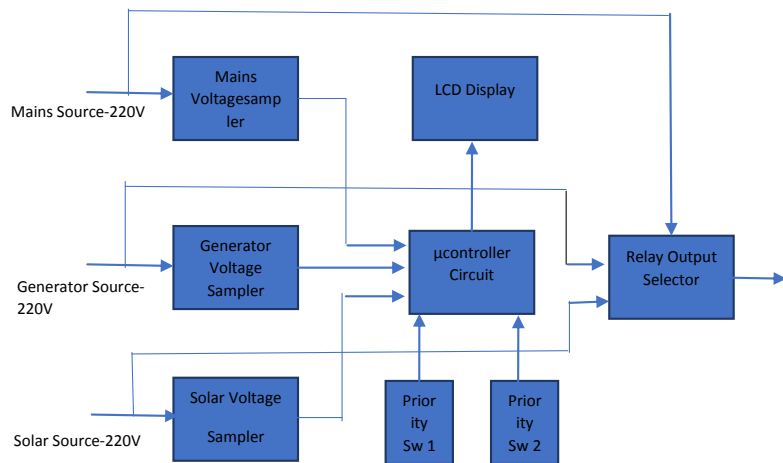

Figure 1: block diagram of the Multiple Source Power Selector

Voltage Sampler Design

Each of the source's voltage is stepped down via a 220V/12V stepped down transformer, the output of which is rectified and filtered to be used by the microcontroller as sample voltage. The connection for sampling is shown in figure 2.0.

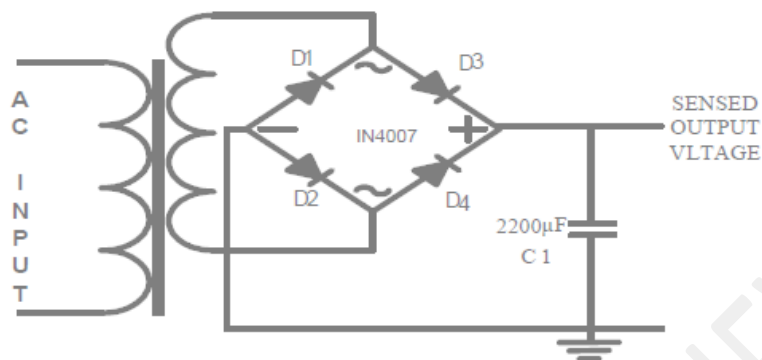

Fig. 2.0: Circuit Diagram of Sensing Unit

Peak Inverse voltage is twice the maximum voltage across the half wave (Mehta, V. K. and Mehta, R., 2008);

That is $PIV = 2VM = 2Vs$

Therefore, $PIV = 2 \times 12 = 24 \text{ V}$

The average DC current (I_{dp}) was calculated using the expression (Theraja, B. L., (2009).);

$$I_{dc} = (2Vm) (\pi RL) \quad (3.3)$$

A 200Ω load resistance was considered across the outputs.

Root mean square (R. m. s) of the secondary = 12 V

Maximum voltage across the secondary (VM) = $12 \times \sqrt{2} = 17 \text{ V}$

Dc current flowing through the load (I_{dc}) = 0.054 A

Average dc voltage across the load (V_{dc}) = $I_{dc} \times RL = 0.054 \times 200 = 10.8 \text{ V}$

However, the values of dc voltages and currents across the three phases were equally 10.8 Volts and 54 mA respectively.

The filter capacitors were calculated using the expression (*Theraja, B. L., 2009*)

$$C = \frac{1}{\sqrt{3}fyR^4} \quad (3.4)$$

But for full wave rectifier circuit;

f = frequency of ripple voltage = 50 Hz

y = Ripple factor = 5% = 0.05

R = Diode resistance = ?

$$R = \frac{V_{dc}}{I_{dc}} = 200 \Omega$$

$$C = 0.000288 \text{ } ^\circ\text{F}$$

$$C = 288 \mu\text{F}$$

Since 288 μ F capacitor is not standard, 330 μ F capacitors were used as in the standard value in the design.

The Circuit Diagram

The completed designed circuit diagram is given in figure 3.0

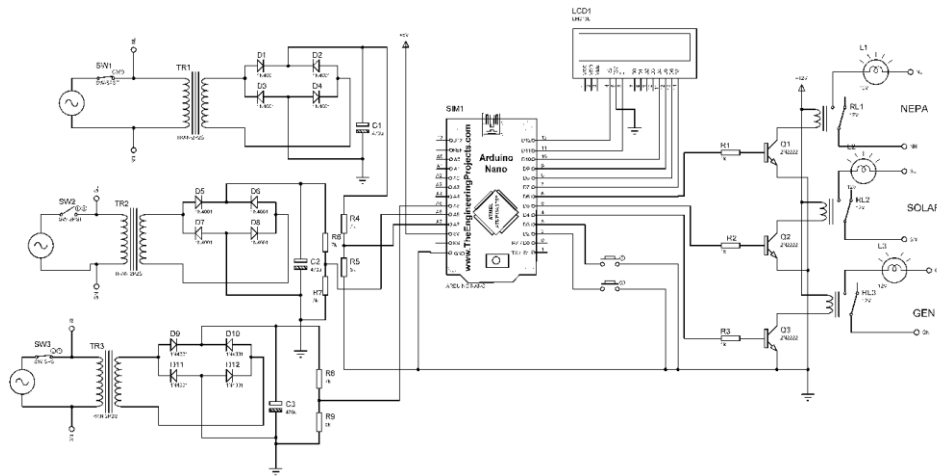

Figure 3.0: The Circuit diagram of the Multiple power source selector

Microcontroller/Programming

The microcontroller employed in this design is an Arduino nano microcontroller. This controller comprises of an ATMEGA328p chip. The Arduino program was written in C++ language, compiled by the Arduino IDE windows program and uploaded into the chip via USB connection.

The flow chart for the logic flow in the program is given in figure 4.0

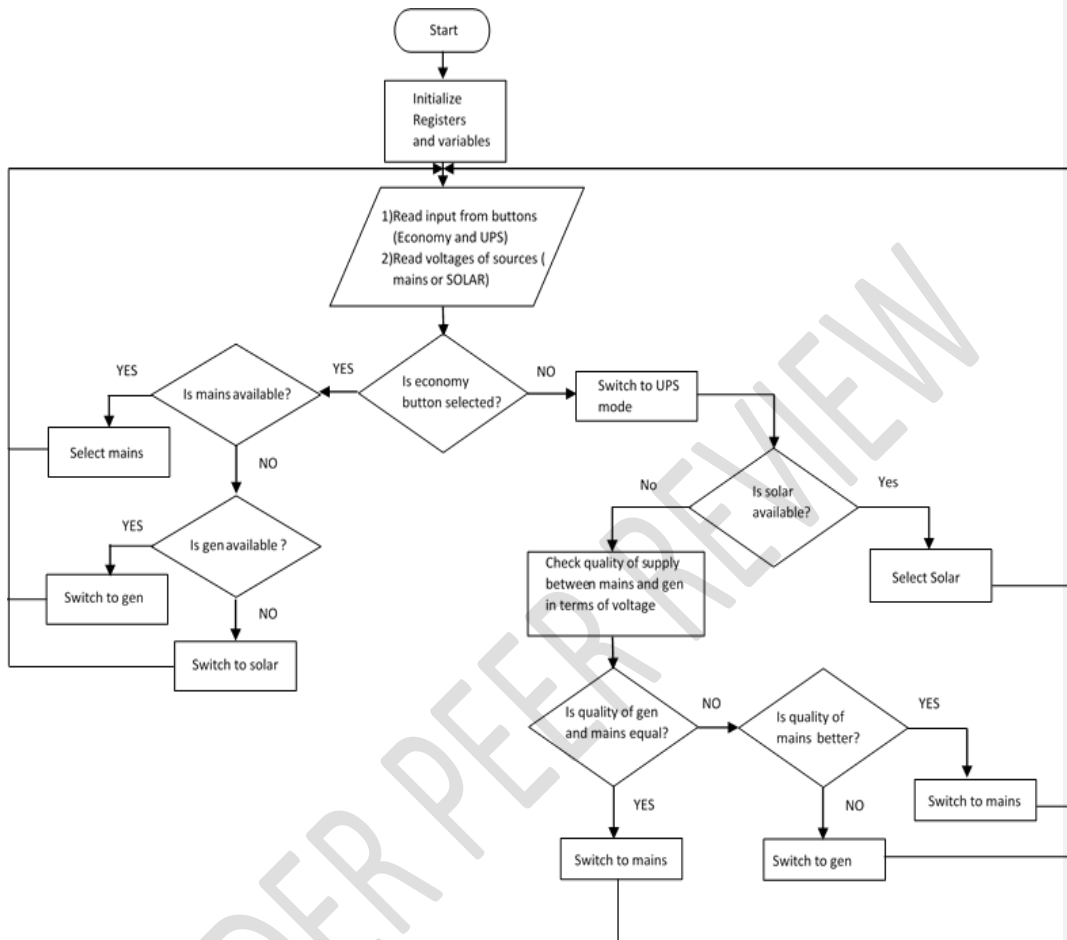

Figure 4.0: The Logic Flow Chart of the Program

Method of Simulation

The designed circuit was drawn in proteus 8.0 software in windows 10 platform. Simulation was done under twodifferent settings as tabulated in table 1.0. and table 2.0. The following scenarios were part of thesimulation.

Scenario 1: Simulation showing mode selection

Scenario 2: Simulation showing output as mains under economy mode when all three sources are available

Scenario 3: Simulation showing output as solar under UPS mode when all three sources are available

Scenario 4: Simulation showing output as gen under UPS mode when all only solar and mains are available

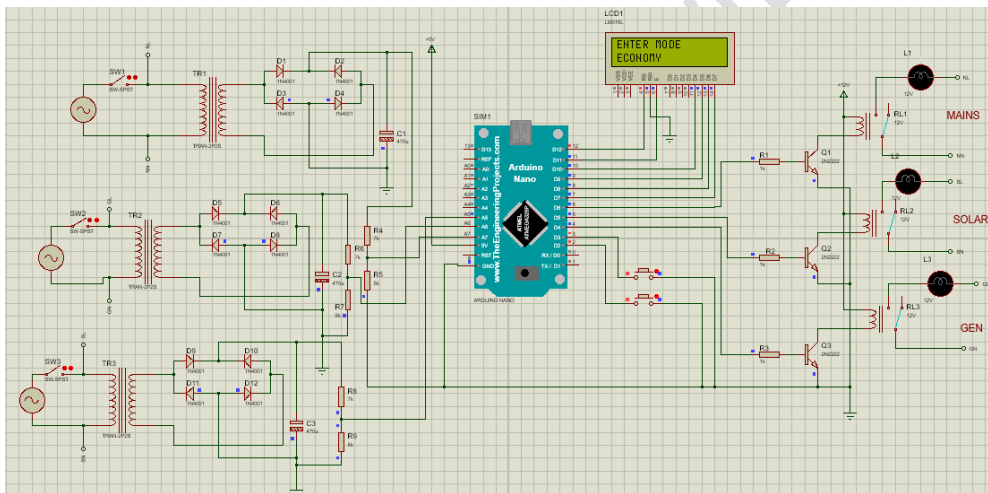

Fig 5: Scenario 1

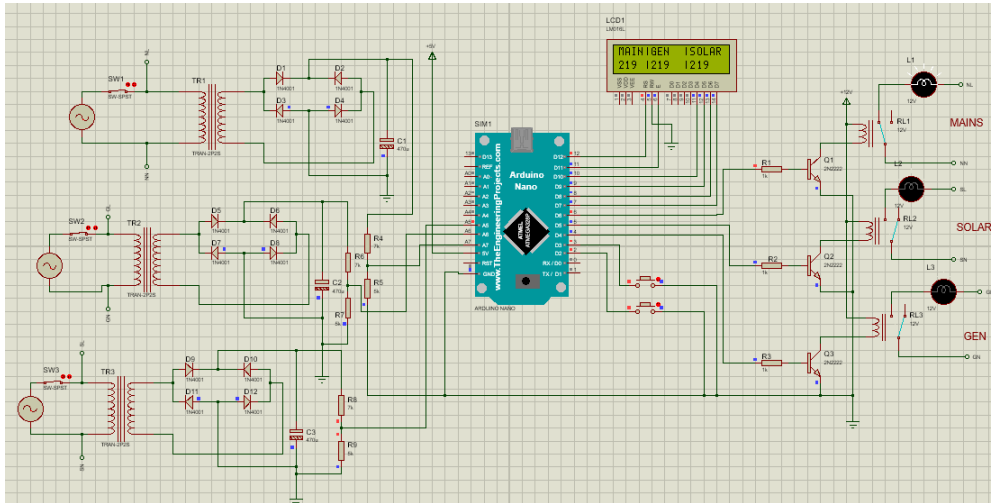

Fig 6: Scenario 2

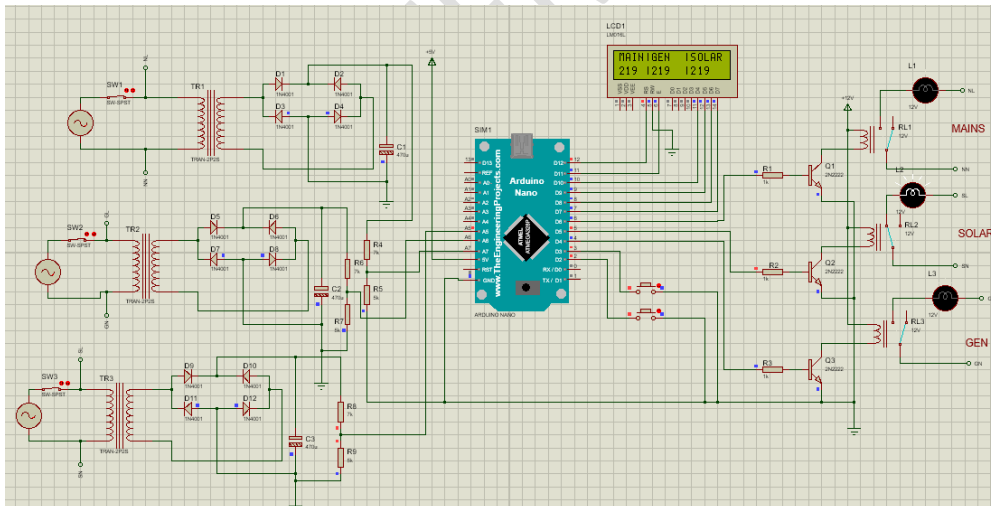

Fig 7: Scenario 3

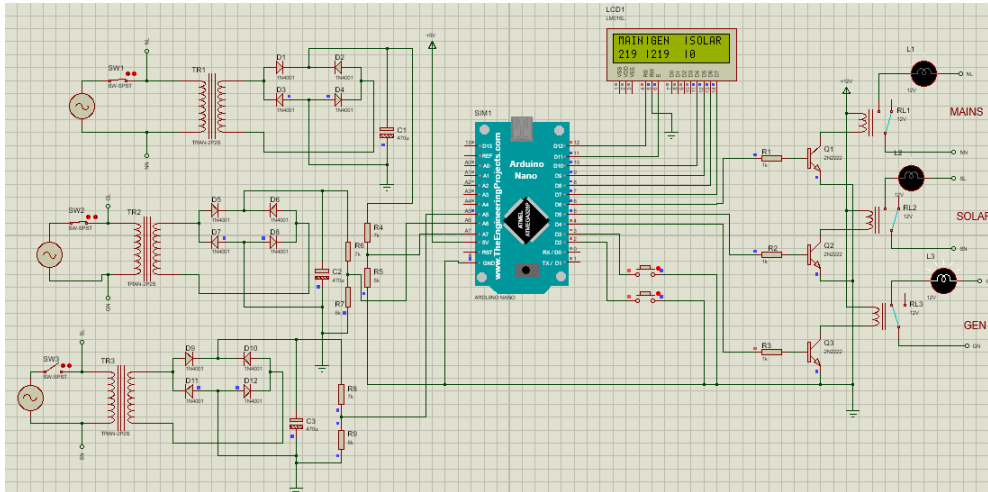

Fig8: Scenario 4

Result and Discussion

Table 1.0: Economy Priority Selected

S/N	Mains Source	Generator Source	Solar Source	Output
1	On	On	On	Mains
2	On	On	Off	Mains
3	On	Off	Off	Mains
4	Off	On	On	Generator
5	Off	On	Off	Generator
6	Off	Off	On	Option to Switch to Solar
7	On	Off	On	Mains

Table 2.0: UP priority selected

S/N	Mains Source	Generator Source	Solar Source	Output
1	On	On	On	Solar
2	On	On	Off	Generator

Comment [pa2]: add discussion

Comment [pa3]: the discussion is less deep, add to the results of research that has been done by other researchers

3	On	Off	Off	Mains
4	Off	On	On	Solar
5	Off	On	Off	Generator
6	Off	Off	On	Solar
7	On	Off	On	Solar

Conclusion

This work sets out the problem of prioritizing the selection of multiple sources based on need of the load. The multiple power source selector with priority option was designed and simulated to automatically select among multiple power sources based on a priority selection. The device improves economy when in economy mode and reduces the possibility of power being off completely when in UP mode. The device is able to detect the most economic source when in economy mode and the most qualitative source when in UP mode.

REFERENCES

Comment [pa4]: add references min 25 journals

- Aderinto, S. (2001). Design and construction of meteorological instruments-the Nigerian Experience. Nigerian meteorological Agency Quarterly Report, Lagos-Nigeria. [http://amper.ped.muni.cz/miler/indi/africa/weather/4\(3\)_Nigeria_1_Aderinto.pdf](http://amper.ped.muni.cz/miler/indi/africa/weather/4(3)_Nigeria_1_Aderinto.pdf)
- Bucci, F., Ciancetta, E., Fiorucci, D., Gallo, C. And Landi, M. (2018). A Low-Cost Ultrasonic Wind Speed and Direction Measurement System. <https://www.semanticscholar.org/paper/A-low-cost-ultrasonic-wind-speed-and-direction-Bucci-Ciancetta>
- Choe, K., Pak, H., Ri, C. and Che, M. (2015, April 6th). Ultrasonic Wind Speed Measurement Using a Polygon Approximation for the Signal Envelope. International Conference on Instrumentation and Measurement, Computer, Communication and Control. <https://www.semanticscholar.org/paper/Ultrasonic-Wind-Speed-Measurement-Using-a-Polygon-Chol-Yong>
- Deutsche Wind Guard. (2018). A report on Calibration of wind direction sensors. Deutsche Wind Guard Wind Tunnel Services GmbH Oldenburger.Varel Germany Project No.: VT180588. <https://www.windguard.de/veroeffentlichungen.html?>

- Fawad, A. (2014). A Cheap Wind Speed and Wind Direction Measurement System. Annual Report on Communication System Engineering, Institute of Space Technology, Islamabad, Pakistan. International Energy Commission (IEC). Wind Energy Generation Systems: Power Performance. 12(1):61400
- Japan Meteorological Agency (JMA). (2019). Measurement of surface wind. <https://www.jma.go.jp/CP4-Wind.pdf>
- Kuojun, X., & Kuijun, W. (2011). Measurement of Wind Speed and Direction with Ultrasonic Sensor Using FPGA. IEEE ICSGCE, Chengdu, China, Energy Procedia 12 (11): 837 – 843.
- Odeyemi, F., And Bakare, B. (2015). Design and Implementation of an Improved Wind Speed Meter (Anemometer). *IOSR Journal of Electronics and Communication Engineering (IOSR-JECE)* 10(1): 36-43
- Pindado, S., Vega, E., Martínez, A., Meseguer, E., Franchini, S. and Sarasola, I. (2011). Analysis of calibration results from cup and propeller anemometers. Influence on wind turbine Annual Energy Production (AEP) calculations. 14: 119–132.
- Rafael, M., Duarte, J., Mauricio, V., Maxwell, M., Costa, R. and Wendell, M. (2013). Ultrasonic Time of flight Estimation for Wind Speed Measurement Based on Time Frequency Domain Using STFT. Workshop Advances in Instrumentation and Sensors Interoperability. Barcelona, Spain. 19(4):78-90
- Siri, B. & Biki, B. (2013). Design & Implementation of an Efficient Windmill Anemometer for Wind Speed Measurement Using Microcontroller. International conference on electrical electronics, information and communication technology (ICEEICT). 978(1):5090-2906
- Triwahju, H., Bambang, S., Dedy, K., & Gunawan, F. (2017). Design of Real Time Anemometer Based on Wind Speed-Direction and Temperature. International Journal of Power Electronics and Drive System (IJPEDS). 8(2): 2088-8694
- Zou, Y., & Wang, Y. (2011). To Measure Wind Speed using the theory of One-dimensional Ultrasonic Anemometer. *Geomorphology*. 6(2jg):234-256.