

DESIGN, FABRICATION, TESTING AND EVALUATION OF A SUSTAINABLE CABINET DRYER FOR DRYING CASSAVA CHIPS

Abstract

The development of a sustainable cassava cabinet dryer requires a balanced approach to technological, economic and ecological aspects. The design – from conceptualization to design and performance evaluation – considered different input parameters and various structural design measures for durability and the ability for the selected materials to withstand thermally induced stress resultant on the drying process, in general and material selection for durable design, in particular. This work sets to design, construct and testing of the cassava chips cabinet dryer. The outcome of tests performed to evaluate the behaviour of the dryer shows that the drying time lies between 210 and 240 for tray 1 and 300 and 330 for tray 2 when compared to the drying time of sun-drying which lies between 720 and 750. This shows that there is evidence of loss of moisture in all the cases. However, loss of moisture in tray 1 of the cabinet dryer appears to be better compare to others. In the real essence, loss of moisture in trays 1 and 2 is expected to occur at the same rate but due to the observed uneven distribution of warm air, and re-absorption of moisture by drying cassava chips, the drying rate differs. Thus, this can be corrected as further improvement on the design. Investment in this design will not only making cassava production much easier and reduce the wastage but will also have a great effect in the economy of the country as recorded to be the highest producer of cassava in the world. This dryer can as well be adapted and used to dryer other food items. The optimum time for drying the cassava was estimated to be 133 mins using multiple regression analysis.

Keywords: sustainable dryer, Forced Convection, Cabinet dryer, Cassava Chips,

1.0 Introduction

The development of a sustainable cassava cabinet dryer requires a balanced approach to technological, economic and ecological aspects. The design – from conceptualization to design and performance evaluation – considered different in input parameters and various structural design measures for durability and the ability for the selected materials to withstand thermally induced stress resultant on the drying process, in general and material selection for durable design, in particular.

Drying technology aims to improve the quality of agricultural products to increase shelf life (Suherman et. al., 2020). Dry cassava chips widely used for alcohol, animal feed and cassava starch industry, alcohol plants, feed mills, starch plants all have a lot of cassava chips consumption. Compared with fresh cassava, cassava chips are more easily to shippment, also can storage longer time (Kosasih et. al., 2020; DOING, 2022). Characteristics and uses of dry cassava chips (Zhang et. al., 2016; Hougue et. al., 2022): low viscosity, low gelatinization temperature, short paste, clear paste, and storage resistant; they are widely used in industries such as food, paper products and modified starch processing. Also, cassava was further characterized (Nwokoro et. al., 2022; Zhang et. al., 2016; Hougue et. al., 2022) has no industrial wastes/residues as all its parts are rich in organic matters and suspended solids. Cassava industrial wastes provide excellent platform to adopt bio-refinery approach.

In Nigeria, optimum utilization of cassava after harvesting is on a fall due to the poor post-harvest practices. Therefore, it is essential to develop a machine that can aid in the drying of cassava chips since proper drying or substantial removal of the moisture content in cassava has proven to be the best way to store cassava, prepare it for further processing, and reduce the level of wastage encountered during its post-harvest processing.

Literatures abound as to the design and development of cassava drying machine. Bourdoux et al. (1982) studied the effects of oven drying on cassava tuber pieces at 60, 105, and 165°C. They found that the cyanide content in fresh tubers decreased from 116.7 mg/kg to 73.5 mg/kg when the chips were dried at 60 °C but was reduced to 28.8 mg/kg at 105°C and less than 1.0 mg/kg at 165°C. (Padmaja, 1995) reported that there is a breakdown of linamarin at higher temperatures and reported to be responsible for the low cyanide values at 105 and 165°C. This singular discovery marks a turning point in the field of cassava and its related studies, as cassava processing machines were developed at higher temperatures of between 105 and 165°C. They found that cyanide retention was dependent on the drying temperature and chip thickness. More cyanide was retained during drying at 60 than 105°C. Likewise (Udoro et. al., 2009) thinner chips (3mm) retained more cyanide than thick chips, which is as a result of faster drying of thin chips which reduced the contact time between linamarase and cyanoglucosides.

Silayo et. al., (2013) investigated the sun drying performance of cassava on various surfaces and drying bed depths. In their study, they showed that the traditional sun-drying method is highly inefficient, as it can take 2-3 days for the product to dry. Mold growth and other issues such as product contamination are likely and therefore require intervention. Interventions included sun drying on a raised platform 1 m above the ground compared to direct box solar dryer drying; by using trays with various bottom surfaces. The experiments were carried out with kiroba variety cassava, which was peeled and cut into thin slices (2-3 mm) and then dried in the sun on wire mesh, black polyethylene, white polyethylene and a woven mat for three days. After drying the cassava for eight (8) hours per day, the cassava was put indoors until day break. The surface with the highest sun-drying performance was wire mesh, while white polyethylene was the least. The 10 mm bed depth reached constant weight in about six hours of drying, while for the 20 and 30 mm bed depth it was about 16 hours and the 40 mm bed depth about 24 hours. There was moisture adsorption that was at 10, 22, and 28 hours for the 10-mm bed depth, 10, 20, 26, and 28 hours for the 20- and 30-mm bed depths, and 28 hours for the 40-mm bed depth. The times 0, 10 and 20 hours marked the beginning of drying while 8, 18 and 28 hours marked the end of drying. Therefore, the best performance was obtained in wire mesh and bed depth of 10 mm and it is recommended for sun-drying cassava. Nevertheless; It is necessary to investigate whether there is a significant quality difference between sun-dried cassava at different bed depths investigated in this study.

The characteristics of microwave hot air drying of cassava in a 2-plane microwave hot air dryer were investigated by Patomsok (2013). Drying experiments were carried out at two levels of sample surface temperature setpoints, viz. 70 and 80°C respectively. Cassava (Rayong-9) with a weight of 2.5 kg and a moisture content of 61% on a wet basis was dried in the dryer for about 5-5.3 h. Drying time was found to decrease with an increase in the sample surface temperature set point. The amount of moisture removed resulting from the drying process was approximately 89%. In all experiments a rapid decrease in moisture ratio values was found followed by a period of gradual decrease. Regarding the drying kinetics, 5 commonly used mathematical models were examined with the experimental data. Diffusion and Page models were found to provide good agreement between experimental and predicted moisture ratio values. The results of the regression indicated that high values of coefficient of determination and adjusted coefficient of determination were reported, as well as low values of standard error of estimation for the case of these two models.

Caitlyn et al, (2009) studied Solar-shed drying of cassava crops. In their study, the initial moisture content was found to be 60.7% which is the mean of three samples. This value was used for the drying at 50°C and 60°C, since the drying at 70°C yielded results where the final moisture content was below 0%, indicating that the value of 60.7% was too low for these samples. At almost moisture content of 0%, which was attained at 70°C, with the assumption the moisture content was 0% after 48

hours of drying. Colour changes were also observed during the drying process; more specifically darker colours appeared in the 3cm layer samples, regardless of the temperature used. The lighter colours, which represent the higher value cassava, were generally present in the 1cm layers, probably because their surfaces dried at a higher rate than the other samples.

Famurewa et al, (2014) carried out modelling of drying pattern of cassava chips at different air velocity and temperature using fluidized bed dryer. In their study, the drying kinetics of cassava chips using a fluidized bed dryer with a view to predicting the most suitable drying model for cassava drying. The experiment was carried out using a 4x4x2 factorial; (air velocities, air temperatures and cassava varieties) with three repetitions for each treatment. 100 g of the wet chips were subjected to drying using a preheated fluidized bed dryer at a specific temperature and varied air speed. The change in mass was recorded at a constant time interval of 20 min until constant weight was achieved. Twelve different mathematical drying models were fitted to the experimental data of moisture ratio against time using nonlinear regression analysis of Sigma Plot 10.0 and Microsoft Excel (2010). Models were compared based on their coefficients of determination (R^2), reduced chi-square (χ^2), root mean square errors (RMSE), and mean bias error (MBE). It was found that the modified model of Henderson and Pabis is the best mathematical model to describe the drying kinetics of cassava flakes for TMS30572 and TMS98/0581, respectively, which have the highest value of R^2 , the minimum values of χ^2 , RMSE and MBE. The result obtained includes; Cassava (TMS98/0581) chips at particular air velocity for varied temperature had higher drying rates than samples from TMS30572, drying curves of dried cassava chips showed a falling rate-drying period only under the experimental conditions employed for both varieties, the highest R^2 value, lowest value of χ^2 , RMSE and MBE for the thin layer drying process for cassava chips from TMS30572 and TMS98/0581 was obtained from the Modified Henderson and Pabis model at constant air velocity and varied temperature (40, 50, 60 and 70°C). Therefore, the Modified Henderson and Pabis model could adequately describe drying characteristics of cassava chips from TMS 30572 and TMS98/0581 than the other models and that air velocity has effect on the drying process of the chips from both varieties as moisture ratio decreases with increase in air velocity at specific temperature.

Benjamin (2011) evaluated three different drying technologies (sol, solar, and bin) used for cassava chip production in Ghana. In their study, moisture content, pH, total titratable acidity, starch yield, bulk density, and paste characteristics were determined for cassava. From the results, container drying at a loading density of 4 kg had the lowest moisture content at 6.77%. A pH value of 6.38 was recorded for drying in containers with a loading density of 2 kg and 4 kg, respectively. The lowest total titratable acidity of 0.24 was recorded for a loading density of 2 kg under the container and sun drying, while sun drying was at a loading density of 3 kg. The starch yield of cassava flour was higher in sun drying (67.74%) than in bin drying. The loading density of 2 kg under sun drying had the highest starch yield of 69.46%. The bulk density of the flour was high in hopper drying (0.74 g/cm³). The dough characteristics of the flour showed that the cooking temperature of the flour was lower in pot drying (67.93 °C). The cassava flour from the sun drying technology had the highest final viscosity of 289.78BU. The 2 kg loading density recorded the highest final viscosity of 278.44 BU. Solar drying at a loading density of 4 kg also resulted in the highest final viscosity of 293.44 BU. Container drying at a loading density of 4 kg had the highest breakdown with a value of 413.00 BU. Among the technologies, the highest setback value of 108.22BU was recorded by cassava flour produced by the bin drying technology. Container drying at a loading density of 2 kg also recorded the highest recoil value of 121.33 BU. Their study showed that sun and solar drying gave a higher yield of starch than container drying.

Sanni, et al, (2015) carried out mathematical modeling of the drying kinetics of thin layer cassava flour in a conductive rotary dryer. In their study, a conductive rotary dryer was developed for the indirect drying of cassava flour for the production of gari and cassava flour. The drum temperature, T_d , the batch quantity, Q_b , and the vapor extraction rate, R_v of the dryer influence the drying kinetics of cassava flour. Cassava flour drying data under different drying conditions were fitted with seven thin layer drying models and the logarithmic model had the best goodness of fit with $R^2 > 0.97$ for each of the parameters. The model constants, a , k and c were generated based on each parameter and three logarithmic models were developed that relate the moisture ratio, MR based on each parameter. The predicted and experimental values of MR correlated well at $R^2 > 0.97$ for each model. The gradients of the moisture loss drying curves, ML , versus drying time, t , were linear between $t = 0$ and a critical time t_c when drying actually stopped. A mathematical model was developed based on the linearity of the drying rate, DR , to predict MR based on T_d , Q_b , R_v and t . The model was validated by comparing the experimental and predicted values of MR in various combinations of dryer parameters. Drum temperature and batch quantity had greater effects on drying kinetics than vapor extraction rate. At $T_d = 200^\circ\text{C}$, the cassava flour was gelatinized and gari with swelling index, $SI > 2.0$, was produced. Cassava flour was produced with $SI < 2.0$ at $T_d = 140^\circ\text{C}$. However, the activation energy required for vaporization was strictly due to heat conduction and not convection. They studied the effects of drum temperature, vapor extraction rate, and amount of cassava flour on drying kinetics. It can be concluded that the drying kinetics of cassava flour in the recently developed conductive rotary dryer can be validly described by the logarithmic thin-layer drying model. However, this study went a step further by showing that, depending on the dryer parameter levels, a linear function of drying rate can be assumed. A general model based on this assumption was developed that accurately predicted the drying kinetics of cassava flour in the conductive rotary dryer. Another result of this study is that both gari and high quality cassava flour (HQCF), which are different but highly demanded food products, can be produced using the same dryer.

Ajayeoba et. al., (2014) designed and developed a locally manufactured biscuit cabinet dryer to be operated in households. The dryer is made up of three sections, the power source (electricity), the fan, and the drying cabinet sections. The power supply is located behind the dryer, which is used to connect the dryer to an electrical source for proper operation. The blower is located in the center of the drying chamber and is rated at 1.02 watts. The blower helps circulate heat for effective and efficient heat flow within the drying cabinet. During this period, the blower helps to maintain the temperature inside the drying chamber. The cabinet is made from 2mm thick mild steel and fiberglass was used as insulation to control conductive heat loss. The trays are perforated to effectively allow airflow into the chamber. The materials used were sourced locally and selected based on the following factors; ability to withstand heat, vibration, humid air fatigue and stress without failure during operation. Basumatary et al (2013) designed and manufactured a multi-food cabinet dryer. The built dryer is a mixed-mode cabin solar dryer where the combined action of the solar radiation that falls on the material to be dried and the air preheated in the solar collector provides the necessary heat for the drying operations. Here, atmospheric air enters through the inlet portion of the solar collector at the lower end, and moist air leaves through the outlet portion. No mechanical or electrical energy is applied. Here, fresh air with atmospheric temperature enters the dryer at the lower end of the solar collector and exits at the top of the drying chamber through the exhaust air outlet.

Akpan et al (2017) designed and developed a locally manufactured agricultural biomaterial. The machine dries agricultural products in batches. Each batch occupies about 60.3 kg on average for the

three trays. The dryer is composed of three units: drying chamber, blower and heat exchanger. Chappell et al (2009) worked on a dryer consisting of a bare plate (made from a metal panel painted black) or corrugated galvanized iron sheet (painted opaque black) with a solar energy collector for heating air. chipboard or thermopile insulation and a multi-stack drying chamber glazed at the front and at the top. The air outlet is through rear side grilles, so the dryer is not equipped with a chimney. However, the tall column of the drying chamber (about 1.27 m) was expected to generate the necessary buoyant head for natural convective airflow. Loading and unloading of the dryer is done through a wooden access door at the rear. The glass front is oriented appropriately, depending on the location of the dryer.

Adesoji et al (2014) in their study, designed, manufactured and tested a five-shelf charcoal-fired dryer for drying rice, tomato, okro and fish to make these products available throughout the year. The multi-food is made up of combustion chamber, heat exchanger, suction unit and drying chamber. Its operation is such that charcoal is burned in the combustion chamber, then the heated air passes through the heat exchanger that filters the hot air with the help of the suction unit before being transported to the drying chamber. In the hot air chamber, the hot air absorbs and transports moisture from the product through the process of heat and mass transfer and diffusion, while the residual air is discharged through the chimney at the top of the chamber. Onifade et al (2016) improved the design of an existing electric crop dryer in order to optimize its efficiency, reduce drying time and produce quality and hygienic products. The cabinet dryer has a chamber to keep the product dry and a means of moving air to generate heat for the drying process. It consisted of three main units, the drying section constructed of mild steel and its inner wall lined with fiberglass to prevent moist air from being drawn from the drying product and to reduce heat loss. The heating section is electric with a temperature regulator that makes the dryer a multipurpose type. It also consists of a heat exchanger, a perforated plate above the heat exchanger to facilitate the uniform distribution of hot air to the drying chamber. At the top of the drying cabinet a steam pipe was mounted through the hot air exhausts from the chamber. The blower section is a centrifugal fan installed and controlled at the control panel with the primary purpose of blowing ambient air to the heater.

In Nigeria, cassava is a large shareholder across the country's vast diet needs to be given more attention to ensure its proper utilization. Employing technological approaches in its production will reduce most and possibly the entire problem faced by the current practices been made and also increases the level of production. Thus, it gives room for research into production of possible derivable products from cassava. Various drying technologies have been developed over the years; adopting one of them in drying cassava into cassava chips will be beneficial as many researchers have been done in these areas for proper guide. However, practical application is yet to be put into play owing to the poor attention given to the agricultural sector of the economy. Considering the situation, investment in most of these technologies are capital intensive and cannot be done by the local farmers but these technologies can be adapted effectively using the local material available to us and still achieve the same result paying attention to all the design processes to ensure the product is user friendly and easily operated with no professional skill required.

Cassava production in Nigeria as well as other agricultural products is yet to meet their full potential due to the level of technological advancement in the nation. With the vast agricultural resources naturally gifted to the nation, adequate technological investment will not only boost the economy of the nation but also grow her to becoming a vital shareholder in the world's economic power.

2.0 Materials and methods

The cabinet dryer is made up of standard and non-standard parts. The standard parts are the electric stove and heating adapted from an aluminum pot. The non-standard parts are the cabinet body and the trays. The fabrication of non-standard parts of the cabinet dryer was done following all manufacturing techniques, such as cutting, joining, grinding and finishing, as needed to actualize the design with infancies on availability due to locality. The cabinet dryer was constructed so as to meet the market standard. Some aspect of the construction work is given in figure 2.1-2.6 of the fabrication section in the appendix.

In view of the design consideration and requirement for the cabinet dryer, the following criteria are considered in evaluating the identified candidate materials for the selection of material for each component of the dryer;

- Mechanical properties
- Thermal properties
- Physical properties
- Manufacturing properties
- Cost

However, weighted property index analysis as a material selection tool is also carried out in selecting the most suitable material for each component of the dryer system and can be seen in Table 1 of the appendix. The materials selected for each component of the dryer to meet the market demand is discussed below.

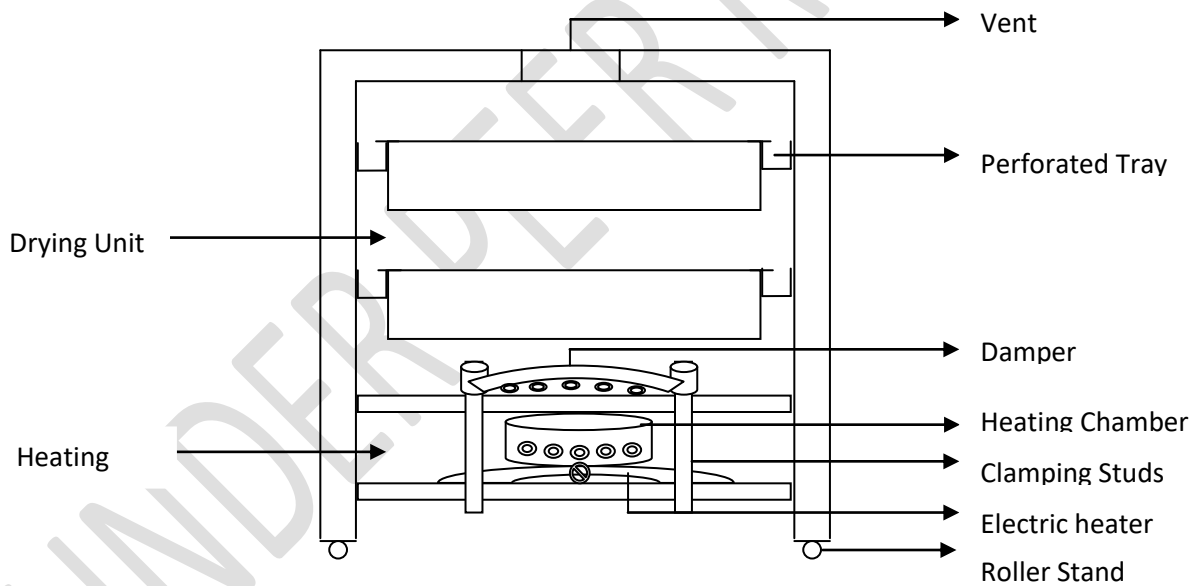

Figure 1 Schematic Diagram of the Cabinet Dryer

Table 1 Material Selection for the Dryer

MATERIALS SELECTION

S/N	Design Components	Required Material	Used Material
1	Cabinet Frame	Galvanized Steel Pipe	Mild Steel Pipe
2	Cabinet Body	Galvanized Steel Sheet Plate	Mild Steel Sheet Plate
3	Drying Tray	Mild Steel	Mild Steel
4	Heat Chamber	Aluminum	Aluminum Pot
5	Damper	Aluminum	Aluminum Sieve
6	Insulator	Fiber Glass	Wood Particles (Saw Dust)

The final materials selected for each component used for the construction was done considering cost and availability of these materials in our immediate locality (Agbarho) so as to ensure that the cost of production will not exceed that affordable by the local farmers who are the intended end users of the product.

2.1. Design Calculations and Analysis

Design Parameters

Some design parameters were used in to assist in the design of the cabinet dryer they are given below;

Table 2 Recorded Daily Temperature in Agbarho in the month of March, 2019 (Google)

Time (hrs)	8:00	9:00	10:00	11:00	12:00	13:00	14:00	15:00	16:00	17:00	18:00
Temperature (°C)	22	23	25	25	26	27	27	27	25	22	22

Table 3: Input parameters used in the computation

Input parameters	Symbol	Computation	Numerical value for input parameters

Initial Moisture Content	MC	Measured	70%
Ambient Temperature (Average)	$T1$	Measured	24.6 °C
Inlet temperature of the dryer		Measured	37°C
Control temperature of the dryer		Measured	80°C
Cabinet Dimension		0.51m*0.41m*0.79m	
Volume of Cabinet		Measured	0.165m ³
Dimension of chips		0.007m*0.003m*0.002m	
Volume of a single chip		Measured	42*10 ⁻⁸ m ³
Dimension of tray section		0.478m*0.35m*0.114m	
Volume of tray section		Measured	0.019m ³
Total volume of the two trays		2*0.019m ³	0.038m ³
Number of chips		0.038/42*10 ⁻⁸ m ³	90476
Number of chips/tray		90476/2	45238
A single chip weighs		measured	1 gram
Total load containable on a single tray		(1*45238)/1000	45.238kg
Total load on both tray		2*45.238	90.476
density of mild steel.	ρ	Measured	7700kg/m ³
volume of the two tray capacity	V	Calculated	0.038m ³

2.1.1 Design for Load Capacity of the Tray

Considering mild steel as material for wire gauze which will be used as the base for the tray construction.

$$l^c = \rho * V \quad [1]$$

$l^c = \text{loading capacity}$

$$l_{max}^c = 7700 * 0.019 = 146.3\text{Kg} \quad [2]$$

$l_{max}^c = \text{Maximum loading Capacity for a single tray}$

2.1.2 Moisture Content Contained in the Dryer

$$M_R = M_R \left[\frac{Q_1 - Q_2}{100 - Q_2} \right] \quad [3]$$

Q_1 =Initial moisture content of the chips

Q_2 =Final moisture content of the chips

M_R = Mass of moisture content removed

M_W = Mass of the wet sample or the dryer capacity per batch in kg.

$Q_1 = 70\%$; 0.7.

$Q_2 = 6\%$; 0.06.

$$M_R = 90.476 \left[\frac{0.7 - 0.06}{1 - 0.06} \right]$$

$M_R = 61.6\text{kg}$

M_D = Mass of dried sample

$$M_D = 90.476 - 61.6 = 28.876\text{kg}$$

Mass of sample after drying is estimated to be 28.88

2.1.3 Design for Heat Duty

$$C_s = 1.005 + 1.88H \quad [4]$$

C_s - The specific heat capacity of air in Agbarho

H- Humidity ratio of air in Agbarho

Ranging temperature within the environment at 20°C-32°C

Ambient temperature of air = 25°C

Relative humidity = 91%

Humidity Ratio = 0.0182kg of water/kg of dry air

$$C_s = 1.005 + 1.88(0.0182) = 1.039216$$

Varied moisture content and temperature resulting in different heat duty and dried sample mass

2.1.4. Quantity of heat required

$$Q_{air} = \left[\frac{M_r}{H_r^1 - H_r^2} \right] \quad [5]$$

Q_{air} = Quantity of heat required

M_r = Mass of moisture content removed

H_r^1 = Humidity ratio at 37°C and Relative humidity of 46%

H_r^2 = Humidity ratio at 80°C and Relative humidity of 6%

From psychometric chart

$H_{r_{ambient}}$ = At 25°C and Relative Humidity of 91% is 0.0182

H_r^1 = At 37°C and relative humidity of 46% is 0.01836

$H_r^2 =$ At 80°C and Relative humidity of 60% is 0.0178

Q_{air} = Actual heat required to remove moisture

$$Q_{air} = \frac{61.6}{0.01836 - 0.0178}$$

$$Q_{air} = 110000\text{j}$$

$$Q_{air} = 110\text{kJ}$$

M_{air} = Mass flow rate required to remove moisture

$$M_{air} = \left[\frac{Q_a}{C_s + \Delta t} \right] \quad [6]$$

$$M_{air} = \frac{110}{1.039216 * (80 - 37)}$$

$$M_{air} = 2.4616\text{kg/hr}$$

$$H = \frac{M_{vapor}}{M_{air}} + H_{25^\circ C} \quad [7]$$

$$H = \frac{2.6956}{2.4616} + 0.0182$$

$$H = 1.1133$$

Humidity of outlet air is 1.1133kg/kg of water

$$V_{air} = \frac{Q_{air}}{\rho_{air}} \quad [8]$$

$$V_{air} = \text{Volume of air}$$

ρ_{air} = The density of air in kg/m^3 is 1.115kg/m^3 at 0°C based on properties of common fluid. (Ehiem et al, 2009).

$$V_{air} = \frac{110}{1.115}$$

$$V_{air} = 98.655\text{m}^3.$$

2.1.5. Quantity of heat required to remove moisture content.

$$Q_{(t)} = M_R C_p \Delta T \quad [9]$$

C_p = Specific heat capacity of water = 4.182

$$\Delta T = 80 - 37 = 43^\circ\text{C}$$

$$M_R = 61.6$$

$$Q_{(t)} = 61.6 * 4.182 * 43 = 11077.28\text{kJ}$$

$$\text{Power} = \frac{\text{quantity of heat required to remove moisture}}{\text{estimated time of drying in seconds}} \quad [10]$$

$$P = \frac{11077.28}{180 \times 60}$$

$$P = 1.02367 \text{kw}$$

Drying time is designed to take at most 3 hours

Therefore the amount of power required to power the heater is 1.3kw

$$1 \text{hp} = 0.746 \text{kw}$$

Therefore 1.3749hp will be adequate for the power heater.

2.1.6. Actual heat used to effect drying

$$H_D = C_{air} T_c M_R V_c \quad [11]$$

C_{air} = Specific heat capacity of air = 1.005KJ/Kg°C

M_R = Amount of moisture removed

T_c = Temperature difference (80-25) =55

V_c = Volume of drying chamber

Dimension of drying chamber = 0.51*0.41*0.381

Volume of drying chamber, V_c = 0.51*0.41*0.381 = 0.0797m³

$$H_D = 1.005 \times 61.6 \times 55 \times 0.0797$$

$$H_D = 271.37 \text{KJ}$$

2.1.7. Rate of Mass Transfer

$$Q_{air} = \left[\frac{M_r}{H_r^1 - H_r^2} \right] \quad [12]$$

$$Q_{MTR} = M_c A_t (H_r^1 - H_r^2) q_2 \quad [13]$$

M_c = Mass transfer co-efficient of free water

$$M_c = 0.083 \text{kg/m}^2 \text{s}$$

A_t = Total Area of two trays = (0.478m*0.35m)*2 = 0.3346m²

$$H_r^1 - H_r^2 = 0.01836 - 0.0178 = 5.6 \times 10^{-4}$$

$$q_2 = 2.2 \times 10^{-6}$$

$$Q = 0.083 \times 0.225 \times 5.6 \times 10^{-4} \times 2.2 \times 10^{-6}$$

$$Q = 2.30076 \times 10^{-12} / \text{s}^2$$

2.1.8. Mass Balance

To determine if the system mass in a dryer is balance this equation is used;

$$m_{air} W_2 + m_p w_1 = m_{air} W_1 + m_p w_2 \quad [14]$$

If L.H.S = R.H.S then the system is balanced.

m_{air} = mass air flow rate

m_p = mass product flow rate

W_1 = Humidity at entry temperature 37°C

w_1 = product moisture content at entry which is 70%

W_2 = Humidity at exit temperature 80°C

w_2 = product moisture content removed (estimation 0.7-0.06) = 0.63.

Time for 61.6kg of moisture to be extracted is 2.9hrs

$m_{air} = 2.4616\text{kg/hr}$

$m_{air} = 6.8378 \times 10^{-4} \text{ kg/s}$

$$m_p = \frac{\text{mass}}{\text{time}} \quad [15]$$

$$m_p = \frac{61.6}{2.9 \times 60 \times 60} = 0.00590 \text{ kg/s}$$

$W_1 = 0.0182$

$w_1 = 0.7$

$W_2 = 0.0178$

$w_2 = 0.06.$

For L.H.S

$$6.8378 \times 10^{-4} \times 0.0178 + 0.00590 \times 0.7 = 0.004142$$

For R.H.S

$$6.8378 \times 10^{-4} \times 0.01836 + 0.0590 \times 0.06 = 0.003553$$

Moisture content that the dryer will vaporize is 70.3%

Therefore the chips can be totally dried without any form of water remaining in the chips within three hours.

2.1.9. Energy Balance

The energy balance for the dryer is determined by the equation given by;

$$m_{air}H_{air}^2 + m_pH_p^2 = m_{air}H_{air}^1 + m_pH_p^1 + q \quad [16]$$

H_{air}^1 = thermal energy of air in kj/kg dry air.

H_p^2 = thermal energy of product kj/kg dry solids

q = energy loss from the drying system

$$H_{air} = C_s(T_{air} - T_0) + WH_L \quad [17]$$

C_s = specific heat capacity of air at that region (agbarho)



Figure 2.1



Figure 2.2



Figure 2.3



Figure 2.4



figure 2.5



figure 2.6

Figures 2.1 to 2.6 show the construction of the cassava dryer

UNDETA



Figure 2.7: Cassava chips before drying



Figure 2.8: Cassava chips after drying



Figure 2.9 Cassava chips used for Testing



Figure 2.10 Cassava chips weighed



Figure 2.11 Digital weighing equipment

using a digital weighing device

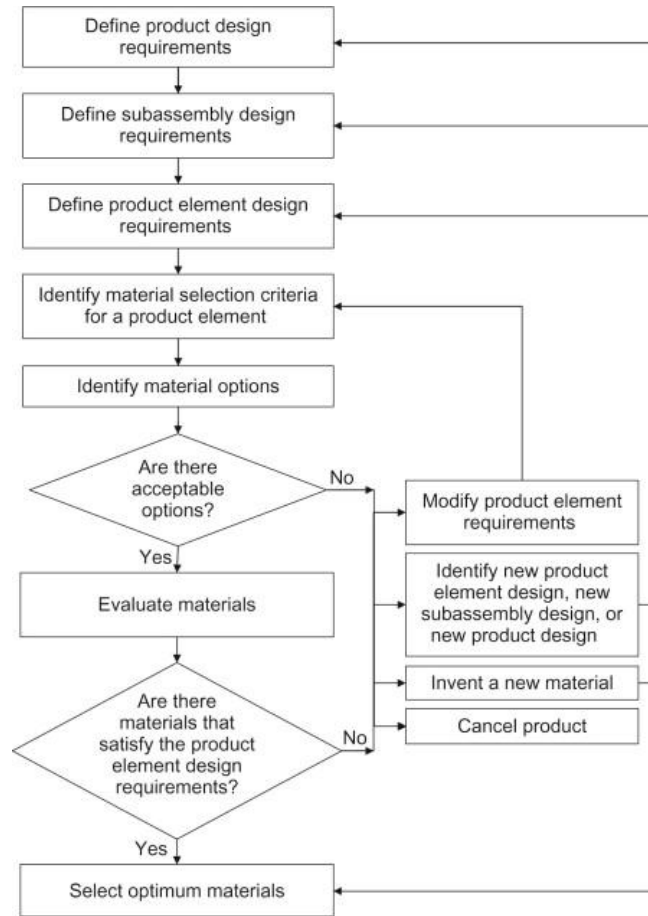

Figure 2.12: Material selection methodology (Myyas et. al., 2016)

Table 4: Weighted Property Index for the Material Selection of the Design Components

Note: Mechanical properties: Weight factor of 10 is assigned

Thermal properties: Weight factor of 20 is assigned

Cost: Weight factor of 40 is assigned

Material (Sheet Metal)	Relative Unit 1 (Thermal Stress) A	Relative Unit 2 (Ultimate Strength) B	Relative Unit 3 (Modulus of Elasticity) C	Relative Unit 4 (Corrosion Resistance) D	Relative Unit 5 (Ease of Fabrication) E	Relative Unit 6 (Melting Point) F	Relative Unit 6 (Cost) G	(1-Cost)	Total Relative Unit (=10A+10B+10C+20D+20E+40F)/110
Mild Steel	0.51	0.8	0.98	0.5	1	0.85	0.01	0.99	0.91
Aluminum	1	0.17	0.34	1	0.5	0.40	0.03	0.97	0.79
Copper	0.75	0.44	0.57	1	0.5	0.65	0.10	0.90	0.81
Brass	0.85	0.83	0.49	1	0.5	0.56	0.04	0.96	0.86
Nickel	0.99	0.04	0.15	1	0.5	0.14	0.29	0.71	0.62
Tin	0.44	0.613	1	1	0.25	0.87	0.19	0.81	0.79
Stainless Steel	0.73	1	0.95	1	0.5	0.90	0.1	0.9	0.94
Titanium	0.36	0.8	0.5	1	0.5	1	1	0	0.50

2.1.11. Statistical modeling

Statistical analyzes Data were presented as mean \pm standard deviation. Mean separation using Duncan's ad hoc test and analysis of variance (ANOVA) was performed using SPSS 16.0® (SPSS Inc., Chicago, Illinois, USA). Multiple regression analysis was performed using Microsoft Excel® 2007 (Microsoft, Redmond, WA, USA). The mathematical adjustment of the experimental data was performed with Curve Expert professional 2.6. The accuracy of the model fit was assessed using the coefficient of determination (R^2), root mean square error (RMSE), and Chi square (2) (Taheri-Garavand et al., 2011; Kim et al., 2009; Darvishi et al., 2012; Zhao et al., 2014).

$$R^2 = 1 - \left[\frac{\sum_{i=1}^n (X_{exp} - X_{pred})^2}{\sum_{i=1}^n (X_{exp} - \bar{X}_{exp})^2} \right] \quad [21]$$

$$RSME = \sqrt{\frac{1}{n} * \sum_{i=1}^n (X_{exp} - X_{pred})^2} \quad [22]$$

$$chi\ square\ (\chi^2) = \sum_{i=1}^n \frac{(X_{exp} - X_{pred})^2}{X_{pred}} \quad [23]$$

3.1 RESULT

3.1.1 Moisture Content Test

Results of moisture content tests run on the cabinet cassava chips dryer are given in Table 5 together with that of sun-drying of cassava chips. For the purpose of comparison, plots of the obtained data are given in Fig 3.1. The figure shows nonlinear plots of percentage moisture contents for sun drying, and cabinet drying in trays 1 and 2 against drying time. It also shows there is significant loss of moisture from cassava chips during sun drying, and cabinet drying in trays 1 and 2. How fast these processes occur differ. In comparison with sun drying, loss of moisture from cassava chips is shown to be faster in tray 2, with shorter drying time. However, it is shown to be fastest in tray 1, with shortest drying time. This can be seen from the initial moisture content of 70%w.b, which gradually reduced to 61.4%w.b, 19.1%w.b and 33.4%w.b for sun drying, and cabinet drying in trays 1 and 2, respectively.

Table 5 Observed data from drying cassava chips

Drying Time (min)	Moisture Content (%): Sun Drying	Moisture Content (%): Drying Tray 1	Moisture Content (%): Drying Tray 2
0	70	70	70
30	69.5	64.5	66.2
60	68.2	57.3	59.1
90	66.8	48.7	52.4
120	65.3	41.5	45.4
150	63.8	31.1	38.3
180	61.4	19.1	33.4

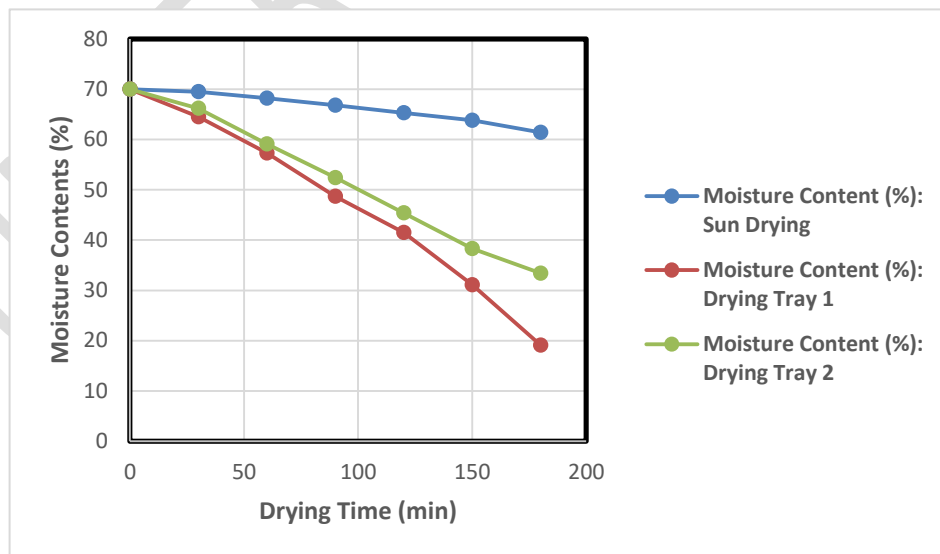

Figure 3.1 Plot of moisture content against drying time

3.2 DISCUSSION

Normally, cassava chips in tray 1 and 2 are expected to dry at the same rate, but due to the observed non-uniform distribution of warm air and re-absorption of moisture by cassava chips in the drying chamber, the outcome is different. This situation is a defect, and therefore, needs to be corrected in future to achieve optimum performance of the dryer. This can be achieved by ensuring the following amendments on the dryer.

- The resistance to warm air flow between trays 1 and 2 is to be minimized through perforated part ways on the sides of the drying trays.
- The inflow of warm air from the damper on the heating chamber is equivalent to the outflow of the same through vent holes on the dryer by properly sizing and numbering the perforations on these parts of the dryer.
- The exiting warm air must be dry so that the drying cassava chips will not absorb moisture from it as it will affect the drying rate.

The general trend of the data shows that a second-order polynomial, or simply, a quadratic equations of the form $MC = aT^2 + bT + c$, where MC is the moisture content and T is the drying time, could be fitted to predict the behavior of the cassava chips subjected to the different drying conditions. Plots of moisture content (MC) against drying time (T) fitted to second-order polynomial trend lines, in MS Excel environment, are shown in Fig 3.2.

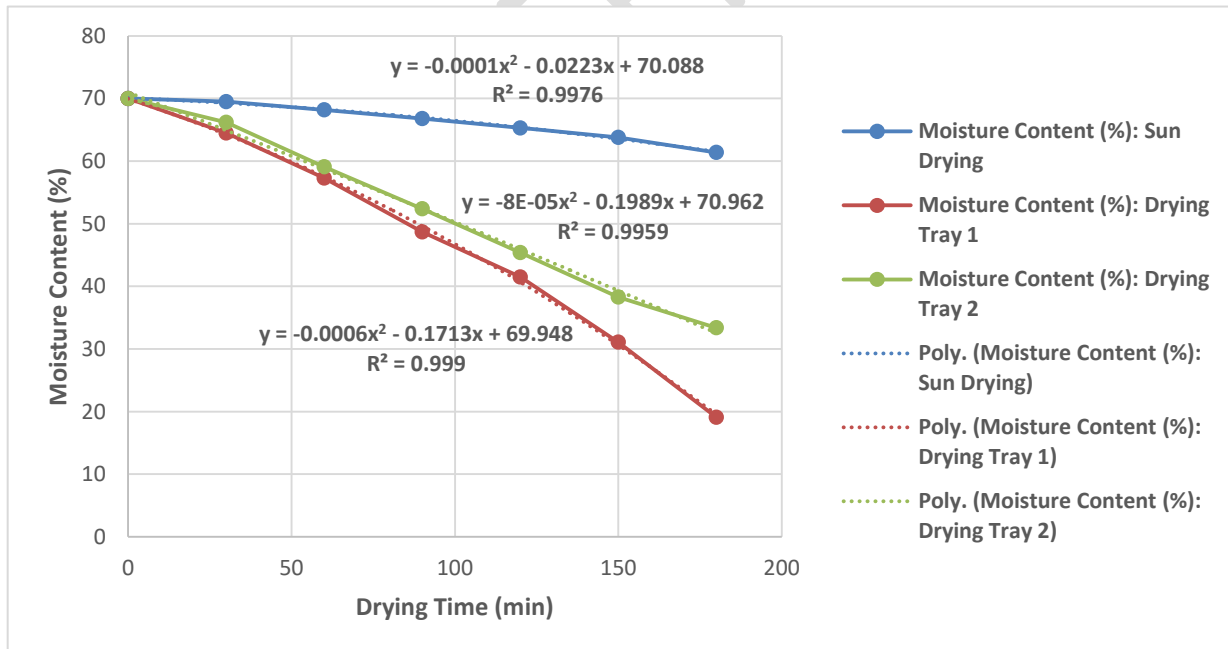

Figure 3.2 Plots of moisture content against drying time fitted to trend lines

The obtained R-squared value of 0.997, 0.999, and 0.9959 for sun drying, and cabinet drying in trays 1 and 2, respectively, show near perfect correlation of moisture content with drying time. They also show the polynomial equation of the second order as a quite suitable equation for

prediction of the total time it will take to completely remove the moisture in the cassava. This can be seen in Table 6, and in a graph showing their relationship as given in Fig 3.3. As shown, the total drying times lie between 720 and 750 min, for sun drying, 210 and 240 min, for cabinet drying in tray 1, and between 300 and 330 min, for cabinet drying in tray 2. The overall performance of the dryer is above average. The drying process was found to be effective as the moisture was significantly removed from the cassava chips. The cassava chips were clean and whitish, free from contaminants after drying.

Table 6 Predicted data from drying of cassava chips

Drying Time (min)	Moisture Content (%): Sun Drying $MC = -0.0001T^2 - 0.0223T + 70.088$ $R^2 = 0.9976$	Moisture Content (%): Drying Tray 1 $MC = -0.0006T^2 - 0.1713T + 69.948$ $R^2 = 0.999$	Moisture Content (%): Drying Tray 2 $MC = -8E-05T^2 - 0.1989T + 70.962$ $R^2 = 0.9959$
0	70.088	69.948	70.962
30	69.329	64.269	64.923
60	68.39	57.51	58.74
90	67.271	49.671	52.413
120	65.972	40.752	45.942
150	64.493	30.753	39.327
180	62.834	19.674	32.568
210	60.995	7.515	25.665
240	58.976	-5.724	18.618
270	56.777	-20.043	11.427
300	54.398	-35.442	4.092
330	51.839	-51.921	-3.387
360	49.1	-69.48	-11.01
390	46.181	-88.119	-18.777

420	43.082	-107.838	-26.688
450	39.803	-128.637	-34.743
480	36.344	-150.516	-42.942
510	32.705	-173.475	-51.285
540	28.886	-197.514	-59.772
570	24.887	-222.633	-68.403
600	20.708	-248.832	-77.178
630	16.349	-276.111	-86.097
660	11.81	-304.47	-95.16
690	7.091	-333.909	-104.367
720	2.192	-364.428	-113.718
750	-2.887	-396.027	-123.213
780	-8.146	-428.706	-132.852
810	-13.585	-462.465	-142.635

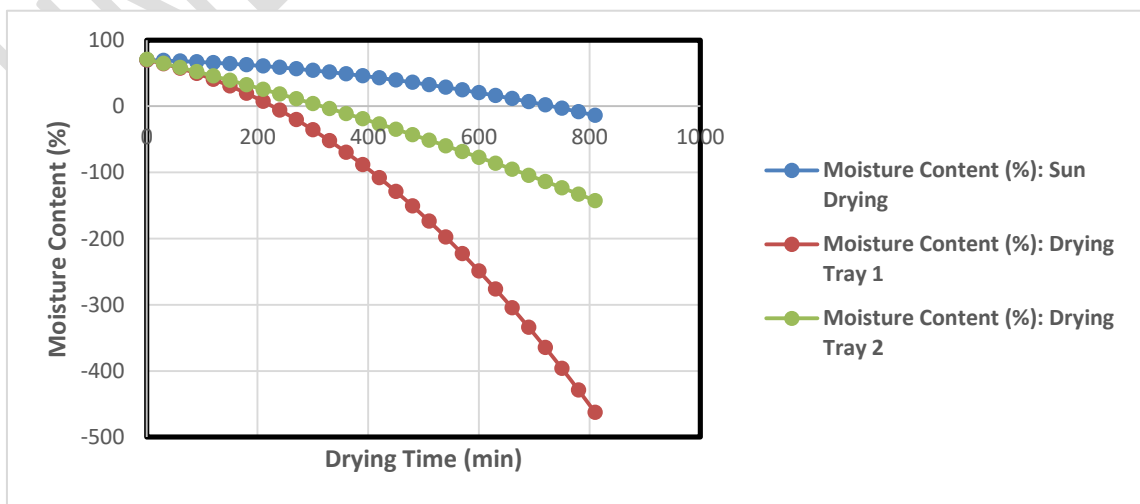

Figure 3.3 Estimated moisture content and drying time

The observed major limitations of the dryer are outlined as follows:

- Frequent power failure within the environment of its used, and high fuel consumption if the power supply is backed with a generating set limits the application of the dryer. Therefore, the need for solar input implemented alongside the electric dryer in hybrid cannot be over emphasized.
- Other limitation includes dryer instrumentation absence of which made it difficult for one to read drying temperature, volumetric warm air flow rate, and moisture removal rate at any given point in time. Thus there is need to include it as part of further improvement in dryer design.
- In attempt to reduce cost, materials used for prototyping of the dryer were not those selected. It will be better if the right materials are used as they will yield better results than the current design and will reduce energy loss.

Apart from these limitations the dryer is suitable for small scale drying of cassava chips as well as drying closely related food items.

Table 7: Results of statistics modeling

SUMMARY OUTPUT

<i>Regression Statistics</i>	
Multiple R	0.99775692
R Square	0.995518871
Adjusted R Square	0.994622645
Standard Error	4.752356356
Observations	7

ANOVA

	<i>df</i>	<i>SS</i>	<i>MS</i>	<i>F</i>	<i>ignificance F</i>
Regression	1	25087.08	25087.08	1110.79	4.57E-07
Residual	5	112.9245	22.58489		
Total	6	25200			

	<i>Coefficients</i>	<i>andard Err</i>	<i>t Stat</i>	<i>P-value</i>	<i>Lower 95%</i>	<i>Upper 95%</i>	<i>ower 95.0%</i>	<i>pper 95.0%</i>
Intercept	333.0554049	7.510666	44.34432	1.1E-07	313.7486	352.3622	313.7486	352.3622
Moisture Content (%): Drying Tray 2	-4.66389209	0.139937	-33.3285	4.57E-07	-5.02361	-4.30417	-5.02361	-4.30417

Multiple R (Correlation Coefficient): Multiple R refers to the degree of linear relationship between the variables.

R Square (Coefficient of Determination): R Square reveals the goodness of fit. That means how many points fit with the regression line. The higher the R Square value, the better fit the regression line you get. Here, the R Square value represents an excellent fit as it is 0.995. It means that the 99% variation in the dependent variable can be explained by the independent variable. In the case of multiple regression relationships, you should pay attention to the adjusted R-square.

Adjusted R Squared: Adjusted R Squared is useful when you have two or more independent variables. As it provides the comparison between the variables which is more important than the other. The value will be greater than R Squared if a new independent variable improves the model or vice versa. In this data set, the adjusted R-squared value is 0.994. That means that 99% of the points fit the regression line.

Standard Error – Simply put, the standard error tells you about the accuracy of your multiple regression analysis. The standard error for this statistical analysis having 7 observations is 4.7523

4.0 Conclusion and recommendation

Cassava chip drying is an effective way of not only preparing cassava for storage, but also, enhances its further processing thereby increasing its level of production and consequently reduce the possible wastage as experienced in cassava production in Nigeria. The design, construction and testing of the cassava chips cabinet dryer has been undertaken. The outcome of tests performed to evaluate the behaviour of the dryer shows that the drying time lies between 210 and 240 for tray 1 and 300 and 330 for tray 2 when compared to the drying time of sun-drying which lies between 720 and 750. This shows that there is evidence of loss of moisture in all the cases. However, loss of moisture in tray 1 of the cabinet dryer appears to be better compare to others. In the real essence, loss of moisture in trays 1 and 2 is expected to occur at the same rate but due to the observed uneven distribution of warm air, and re-absorption of moisture by drying cassava chips, the drying rate differs. Thus, this can be corrected as further improvement on the design. Investment in this design will not only making cassava production much easier and reduce the wastage but will also have a great effect in the economy of the country as recorded to be the highest producer of cassava in the world. This dryer can as well be adapted and used to dryer other food items.

References

A.T. Mayyas, A.R. Mayyas, M. Omar, 11 - Sustainable lightweight vehicle design: A case study in eco-material selection for body-in-white, *Lightweight Composite Structures in Transport*, Woodhead Publishing, 2016, Pages 267-302, ISBN 9781782423256, <https://doi.org/10.1016/B978-1-78242-325-6.00011-6>.

Charles Chigemezu Nwokoro, Christine Kreye, Magdalena Necpalova, Olojede Adeyemi, Matti Barthel, Pieter Pypers, Stefan Hauser, Johan Six, Cassava-maize intercropping systems in southern Nigeria: Radiation use efficiency, soil moisture dynamics, and yields of component crops, *Field Crops Research*, Volume 283, 2022, 108550, ISSN 0378-4290, <https://doi.org/10.1016/j.fcr.2022.108550>.
(<https://www.sciencedirect.com/science/article/pii/S0378429022001216>)

Darvishi, H., Banakar, A., Zarein, M., 2012. Mathematical modeling and thin layer drying kinetics of carrot slices. *Glob. J. Sci. Front. Res. (GJSFR)* 12, 57e64.

Elohor O. Udoro, Olasunkanmis. Gbadamosi and Kehinde A. Taiwo, Chapter 17 of *Using Food Science and Technology to Improve Nutrition and Promote National Development*, Robertson, G.L. & Lupien, J.R. (Eds), © International Union of Food Science and Technology (2008) Studies on the production and utilization of dried cassava flakes as human food

Engkos Achmad Kosasih, Ahmad Zikri, Muhammad Irfan Dzaky, Effects of drying temperature, airflow, and cut segment on drying rate and activation energy of elephant cassava, *Case Studies in Thermal Engineering*, Volume 19, 2020, 100633, ISSN 2214-157X, <https://doi.org/10.1016/j.csite.2020.100633>. (<https://www.sciencedirect.com/science/article/pii/S2214157X20300708>)

Jerome Anani Houngue, Serge Sètonджи Houédjissin, Corneille Ahanhanzo, Justin S. Pita, Méline S. Ella Houndénoukon, Martine Zandjanakou-Tachin, Cassava mosaic disease (CMD) in Benin: Incidence, severity and its whitefly abundance from field surveys in 2020, *Crop Protection*, Volume 158, 2022, 106007, ISSN 0261-2194, <https://doi.org/10.1016/j.cropro.2022.106007>. (<https://www.sciencedirect.com/science/article/pii/S026121942200103X>)

https://www.cassavaprocessingplant.com/news/cassava_chips_uses_1321.html assessed on 5/19/2022 @ 4:55 pm

Ming Zhang, Li Xie, Zhixuan Yin, Samir Kumar Khanal, Qi Zhou, Biorefinery approach for cassava-based industrial wastes: Current status and opportunities, *Bioresource Technology*, Volume 215, 2016, Pages 50-62, ISSN 0960-8524, <https://doi.org/10.1016/j.biortech.2016.04.026>.

Suherman Suherman, Evan Eduard Susanto, Asif Widodo Zardani, Nur Haniza Roviqoh Dewi, and H. Hadiyanto, Energy-Exergy Analysis and Mathematical Modeling of Cassava Starch Drying with a Hybrid Solar Dryer, *Compelling Engineering*, Vol. 7, no. 1. 2020, <https://doi.org/10.1080/23311916.2020.1771819>

Taheri-Garavand, A., Rafiee, S., Keyhani, A., 2011. Mathematical modeling of thin layer drying kinetics of tomato influence of air dryer conditions. *Int. Trans. J. Eng. Manag. Appl. Sci. Technol.* 2, 147e160.

Zhao, P., Ge, S., Ma, D., Areprasert, C., Yoshikawa, K., 2014. Effect of hydrothermal pretreatment on convective drying characteristics of paper sludge. *ACS Sustain. Chem. Eng.* 2, 665e671.