

Analysis of an electrical transmission tower by CFD: a comparison to the Mexico Standards

ABSTRACT

Place and duration of Study: Faculty of Engineering, Autonomous University of Queretaro, January 2022 to May 2023.

This study analyzed wind pressures in two ways: first, according to current Mexican standards, and second, by performing a dynamic wind analysis using Computational Fluid Dynamics (CFD).

The present study focused on analyzing the transmission tower E71W21, which is commonly used as a suspension tower in Mexico. This tower has a height of 46.9 m and a base of 12 m, and is similar to the type of towers that collapsed in the city of Los Cabos, Mexico, by the passage of Hurricane Odile in 2014.

Current regulations establish that transmission line towers may be out of scope and must be designed with particular specifications for each case, by numerical models and experimental studies in the wind tunnel.

Two models were made, the first model which consisted of dividing the tower into 5 parts, in order to reduce the computational cost. The model was detailed by modeling the bars with their corresponding section and simplified to the most predominant thickness of the section. The second model is the complete tower as a rigid solid without distinction between the elements.

The wind pressure values obtained using the current standards in Mexico and according to specification J100-50 were found to be 15-20% lower than the values obtained from the CFD simulation results. The difference can be presented by the mesh quality, turbulence model used, or simplifications by the need to reduce the computational cost. The analysis results are presented graphically as pressure and velocity contours, as well as streamlines.

Computational fluid dynamics is a very useful tool for simulating physical experiments such as in a wind tunnel, although it cannot replace the need for physical experimentation. With the help of high-performance computers, Computational fluid dynamics models offer a detailed exploration of physical phenomena.

Keywords: Wind Forces, computational fluid dynamics, electric transmission tower, Mexican Standards, Pressure and suction forces.

1. INTRODUCTION

Mexico has approximately 11,122 km of continental coastline, which border two important oceans, the Pacific and the Atlantic. Due to its geographic location and oceanic activity, Mexico has regions prone to recurrent hurricane impact. The regions with the highest frequency of impacts are the peninsulas of Baja California and Yucatan.; The coasts of Nayarit, Jalisco, Colima, Michoacan, Guerrero, Oaxaca, Chiapas, Veracruz and Tabasco are also areas with recurrent impact.

Mexico is the only country in the world with two sources of hurricanes in the world, has the ideal conditions of latitude and sea temperature during summertime [1].

On September 14, 2014, hurricane Odile, category III on the Saffir-Simpson scale made landfall in Baja California Sur, entering through Cabo San Lucas with speeds of 205 km/h and wind gusts up to 240 km/h, the consequences of this hurricane on the infrastructure of the state of Baja California Sur in economic terms is estimated at more 24 billion pesos, furthermore, ninety- five percent of users were affected by the lack of electrical energy for damage to the electricity sector (transmission lines).This hurricane has been one of the highest wind speeds made landfall in Baja California Sur.

Although there are design manuals available for the design of transmission towers as the Civil Works Design Manual (MDOC, for its acronym in Spanish) and specification J100-50 of the Federal Electricity Commission (CFE, for its acronym in Spanish), with the passage of hurricane Odile, the vulnerability of transmission tower to the action of the wind it became evident. In contrast to the other types of structures, transmission towers are sensitive to wind turbulence and have natural periods that present unstable aerodynamic problems. Hurricane Odile did the most damage to transmission infrastructure of the history of the Federal Electricity Commission, an approximate damage of 534 transmission towers and 7,963 electric poles in the distribution of electric power [2].

Electricity is an indispensable factor in the development and operation of the country, the failure of some of the elements that compose the power transmission lines is the cause of economic losses and loss of life.

In view of the evidence of power transmission tower failures after the passage of hurricane Odile, it is proposed to evaluate the wind pressures with a model of computational fluid dynamics (CFD) and it have compared with the current standards in Mexico (update after hurricane Odile), to determine the difference between the two methods.

Computational fluid dynamics (CFD) is a valuable tool for research and the design of systems involving the movement of fluids. CFD uses numerical methods to simulate the behavior of liquids and gases with surfaces. Due to the complexity of the equations that govern the behavior of fluids, CFD problem solving involves an iterative process that seeks to achieve an acceptable residual.

The conservation of mass is based on the Reynolds transport theorem applied to a control volume and can be expressed as follows:

$$\int_{VC} \frac{\partial \rho}{\partial t} dV + \int_{SC} \rho \vec{V} \cdot \vec{n} dA \quad (1)$$

Applying the divergence theorem to the above equation, it transforms from a volume integral to an area integral over the surface area of the volume.

$$\int_V \vec{v} \cdot \vec{G} dV = \oint_A \vec{G} \cdot \vec{n} dA \quad (2)$$

Substituting equation 2 into 1, results a general differential equation called the continuity equation.

$$\frac{\partial \rho}{\partial t} + \vec{v} \cdot (\rho \vec{v}) = 0 \quad (3)$$

For the conservation of the quantity of linear motion we have a differential equation called Cauchy equation.

$$\frac{\partial}{\partial t} (\rho \vec{v}) + \vec{v} \cdot (\rho \vec{v} \vec{v}) \quad (4)$$

In conclusion, we solve the Navier Stokes equation, the basis for Computational Fluid Dynamics (CFD), which is a second order nonlinear partial differential equation defined as:

$$\rho \frac{D\vec{v}}{Dt} = -\vec{\nabla} P + \rho \vec{g} + \mu \nabla^2 \vec{v} \quad (5)$$

Where ρ is the density of the fluid, \vec{v} is the fluid velocity, t is the time, P is the fluid pressure, g is the acceleration due to gravity, μ is the dynamic viscosity of the fluid and $\vec{\nabla}$ is the nabla operator, which operates on vector and scalar fields.

Engineers and designers use CFD to understand the behavior of fluids and improve the efficiency and performance of the systems that use them[3]. A CFD model can be used to understand important physical aspects of the flow field similar to those that can be seen visually in a laboratory by experimenting with a wind tunnel [4], this is one of the reasons why current regulations establish that transmission line towers may be out of scope and must be designed with particular specifications for each case, in this case CFE Specification J 1000-50 or with the support of numerical models, experimental studies in the wind tunnel, a CFD model was used in this paper.

Several international investigations have been made to evaluate wind-induced forces for lattice towers or electric transmission towers by computational fluid dynamics [5,6,7,8], the values obtained with computational fluid dynamics (CFD) are reasonably compared with regulations in different countries, it is concluded that CFD analysis is a theoretical and practical modeling tool for the optimization of structures subjected to wind flow.

A lot of research has been done, recommends simulating transmission towers by approximating them as a porous medium, with the objective of reducing the number of finite volumes in order to reduce the computational cost [9,10,].

Turbulence and wind gusts are caused by eddies or vortices within the air flow. These vortices occur due to friction on the earth's surface or shearing between air moving in opposite directions at high altitudes.

When wind interacts with a structure, as an electrical transmission tower, air flow is diverted, which produces suction on the opposite side in the normal direction of the wind. This

phenomenon is visible in the angles of the tower, with CFD model is possible to visualize these phenomena by streamlines, which help us to understand and analyze the flow behavior in complex systems.

2. METHODOLOGY

The structure analyzed is an E71W21 suspension tower with a height of 46.9 m and a 12 m of base, tower used in Mexico as a suspension tower, this tower is similar to those that collapsed in Los Cabos, Baja California Sur, Mexico by the passage of Hurricane Odile.

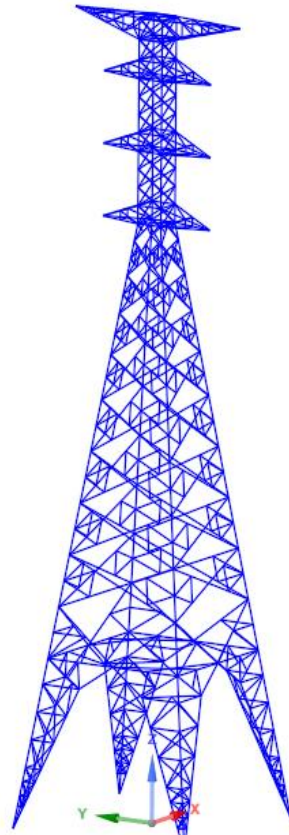

Figure 1 Transmission tower E71W21

To obtain the wind pressures for the supporting structure, must be analyzed at least two horizontal directions, perpendicular to each other, directions with wind angle of attack with respect to the tower of 0° and 90° were analyzed.

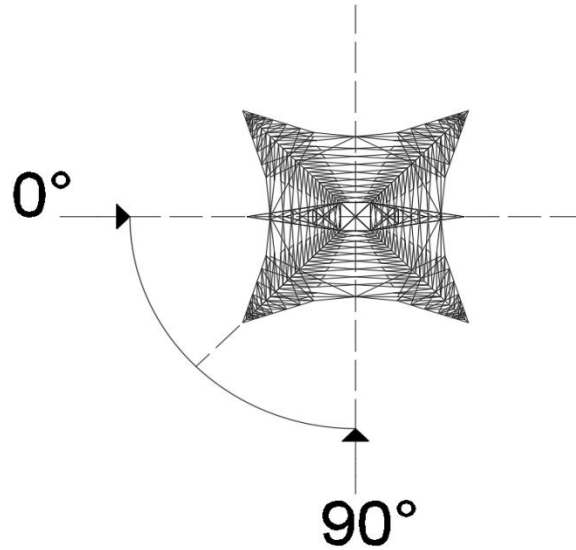

Figure 2 Directions for analysis

For a transmission tower it is necessary to use a dynamic analysis to evaluate the dynamic interaction between the wind flow and the structure. The Civil Works Design Manual (MDOC 2020) and the National Electricity Commission specification J1000-50, its purpose is the analysis, design and manufacture of self-supported towers used in transmission lines in Mexico [11,12], figure 3 shows the steps to follow to obtain the wind pressures in the tower.

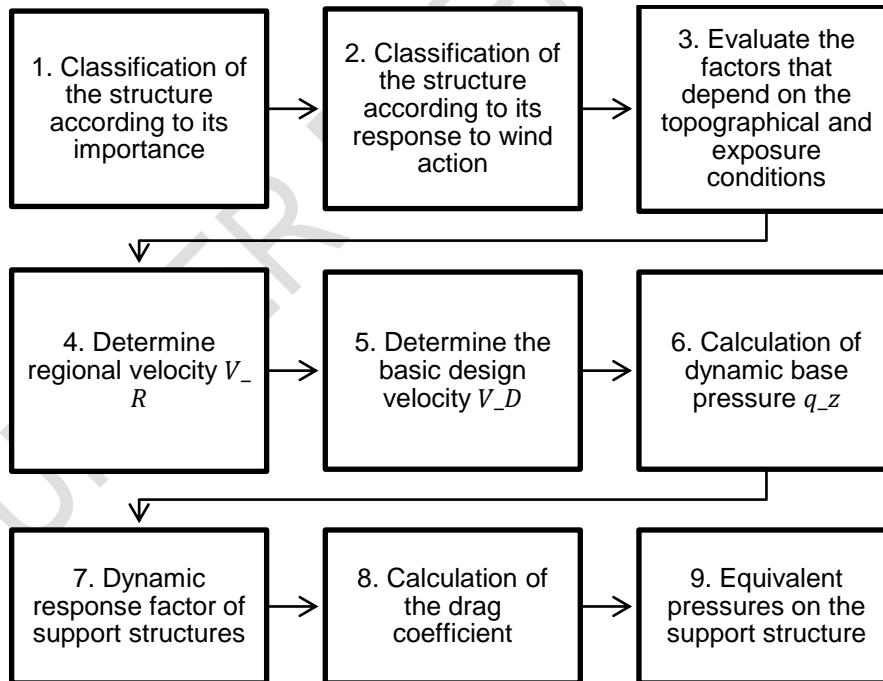

Figure 3 Steps for developing a dynamic wind analysis according to the specification J1000-50 (2019).

For the simulation of fluids in the CFD model, the methodology to be followed is described in Figure 4.

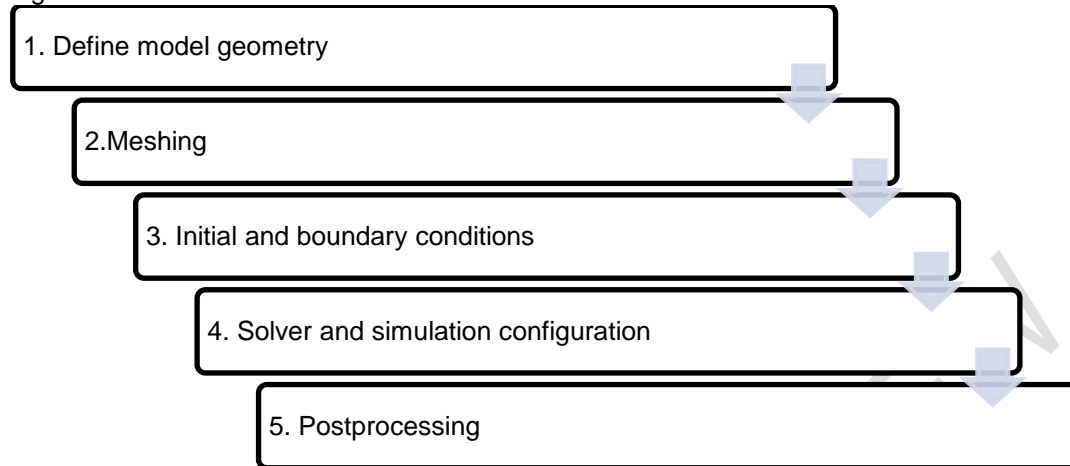

Figure 4 Steps for CFD model development.

We defined the geometry, imported the file that was previously drawn, the geometry of the tower was drawn as a rigid solid, without distinction between the elements and exported as an IGES file.

Two geometries were made, the first model consisted of dividing the tower into 5 parts, to reduce the computational cost, was detailed by modeling the bars with their corresponding section and simplified to the most predominant thickness of the section, which was 0.0048m. The second was modeled as a solid volume.

For the CFD model a control volume has been established, its dimensions were chosen based on the ratio that the height of the control volume should be 5 times the height of the geometry to be analyzed and a width on each side of 2.3 times the height of the tower, the distance to the front of the tunnel should be 5 times the height, the distance behind the tower is 15 times the height [13].

In the same way, a parameter that helps to define a correct size in the control volume is the blocking ratio. A maximum blocking rate of 5% for wind tunnel research and 3% for CFD model research is suggested [14]. The blocking ratio was kept between 1% to 2% maximum, for the simulation.

The quality of the mesh is verified with the parameters of orthogonal quality, if it is close to unity, the mesh has an excellent quality, the other parameter is the asymmetry, if it is close to zero, a good quality mesh is obtained.

Numerical parameters and solution algorithms are selected, a k-epsilon model and a coupled scheme based on least-squares cells were used. The first approximation values for the flow field variables are specified for each cell (initial conditions), the design velocity was used (V_D) with equation 6 for the upper panel of the segment to be analyzed in which the tower body was subdivided for the analysis in the CFD environment.

$$V_D = F_T F_{Tz} V_R \quad (6)$$

Where F_T factor depending on local topography, F_{rz} Local exposure factor and V_R regional burst velocity.

Starting with the first interaction values, interactions are made until the residual becomes almost equal to zero for each cell of the domain (convergence of the solution). When the solution converges, flow field variables such as velocity and pressure are plotted and analyzed graphically.

The convergence criteria used was 10^{-4} , it was established that the scaled residuals are reduced by 4 orders of magnitude, the convergence measure the imbalance or error in the conservation equations, to corroborate that the CFD model was viable, a mesh convergence analysis was performed by varying the control volume and the mesh configuration, increasing the number of elements.

Once the simulation is completed, move on to the final stage, which is post-processing, where Figure 5 shows the flow chart for CFD postprocessing.

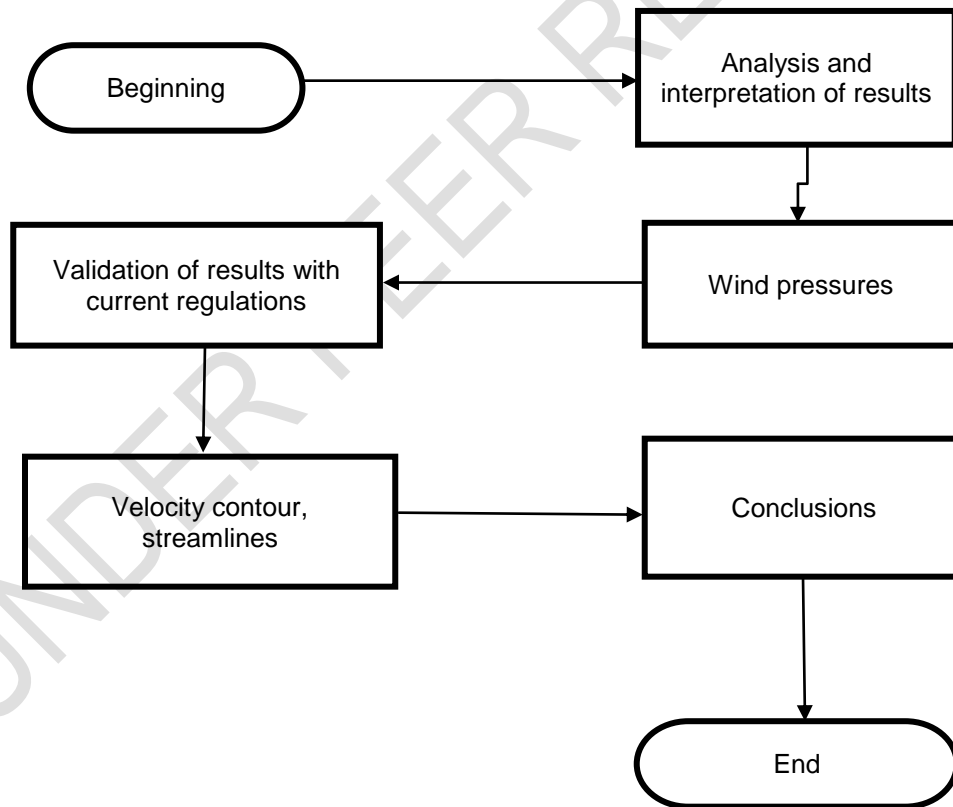

Figure 5 Steps for CFD postprocessing

3. RESULTS AND DISCUSSION

With the values calculated with Equation 6, the design velocities were obtained, used as boundary conditions on the inlet side for each segment analyzed (see Table 1).

Table 1 Design velocity values for each tower segment E71W21

Segment	Height (m)	V_D (km/h)	V_D (m/s)
A	11.00	233.000	64.722
B	34.20	249.700	69.361
C	39.43	251.860	69.961
D	43.63	253.420	70.394
E	45.99	254.240	70.622

The velocity profile for tower E71W21 is shown in Figure 6.

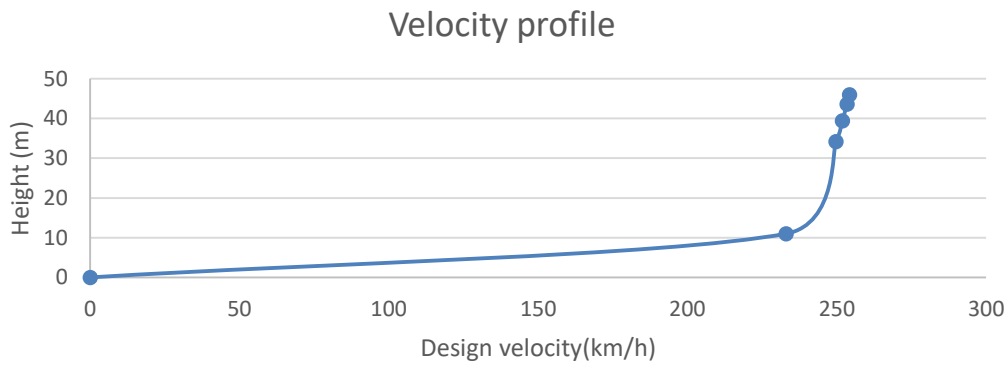

Figure 6 Tower velocity profile E71W21

Table 2 and 3 show the differences between the pressures obtained from the models with an analysis direction at 90° and 0°, compared with those obtained based on CFE standards in Mexico (MDOC).

Table 2 Pressure differences between the current standard and the CFD model at 90°

Segment	Height (m)	Pressures (Pa)		% Difference
		MDOC (2020)	CFD	
A	11.00	2692.40	3203.12	18.97
B	34.20	3092.00	3801.98	22.96
C	39.43	3146.10	3653.98	16.14
D	43.63	3185.20	3657.54	14.83
E	45.99	3205.76	3673.05	14.58

The maximum difference of pressures is in the last segment, this may be due to the fact that the pressure increases around the height, also the upper crossheads presented difficulty for the meshing due to the directions of their crossheads, this may influence the differences.

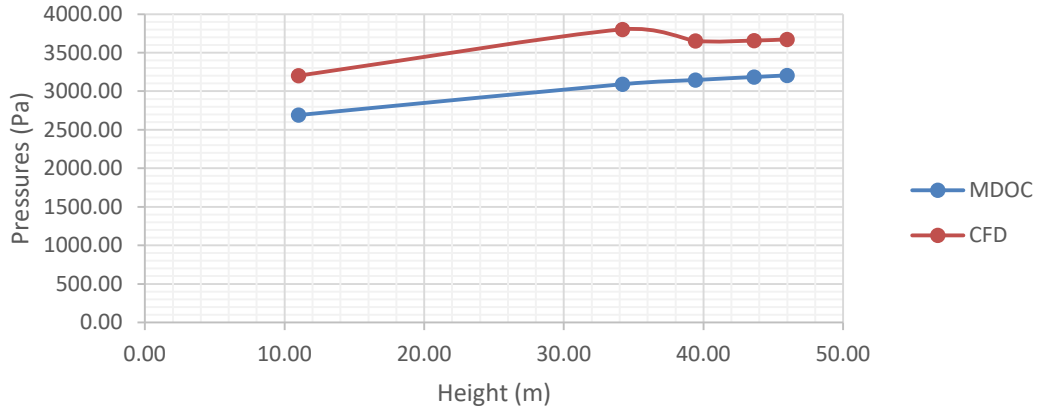

Figure 7 Comparison of pressures on the tower at 90°.

Table 3 shows the differences between the pressures obtained from the model with an analysis direction at 0°, compared with those obtained based on CFE standards in Mexico, there is an average difference of 16%.

Table 3 Pressure differences between MDOC (2020) and CFD model at 0°

Segment	Height (m)	Pressures (Pa)		% Difference
		MDOC (2020)	CFD	
A	11.00	2692.40	3203.12	18.97
B	34.20	3092.00	3801.98	22.96
C	39.43	3146.10	3542.67	12.60
D	43.63	3185.20	3547.38	11.37
E	45.99	3205.76	3645.8	13.73

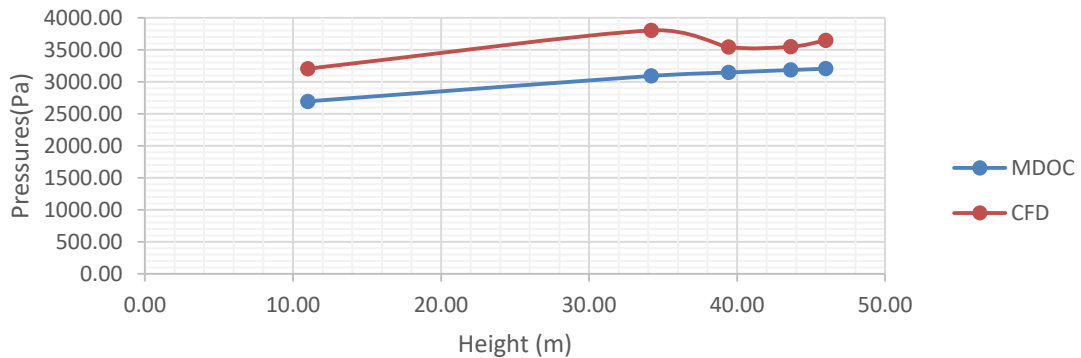

Figure 8 Comparison of pressures on the tower at 0°.

The following section shows the images corresponding to the post-processing of the CFD models (see figure 9,10).

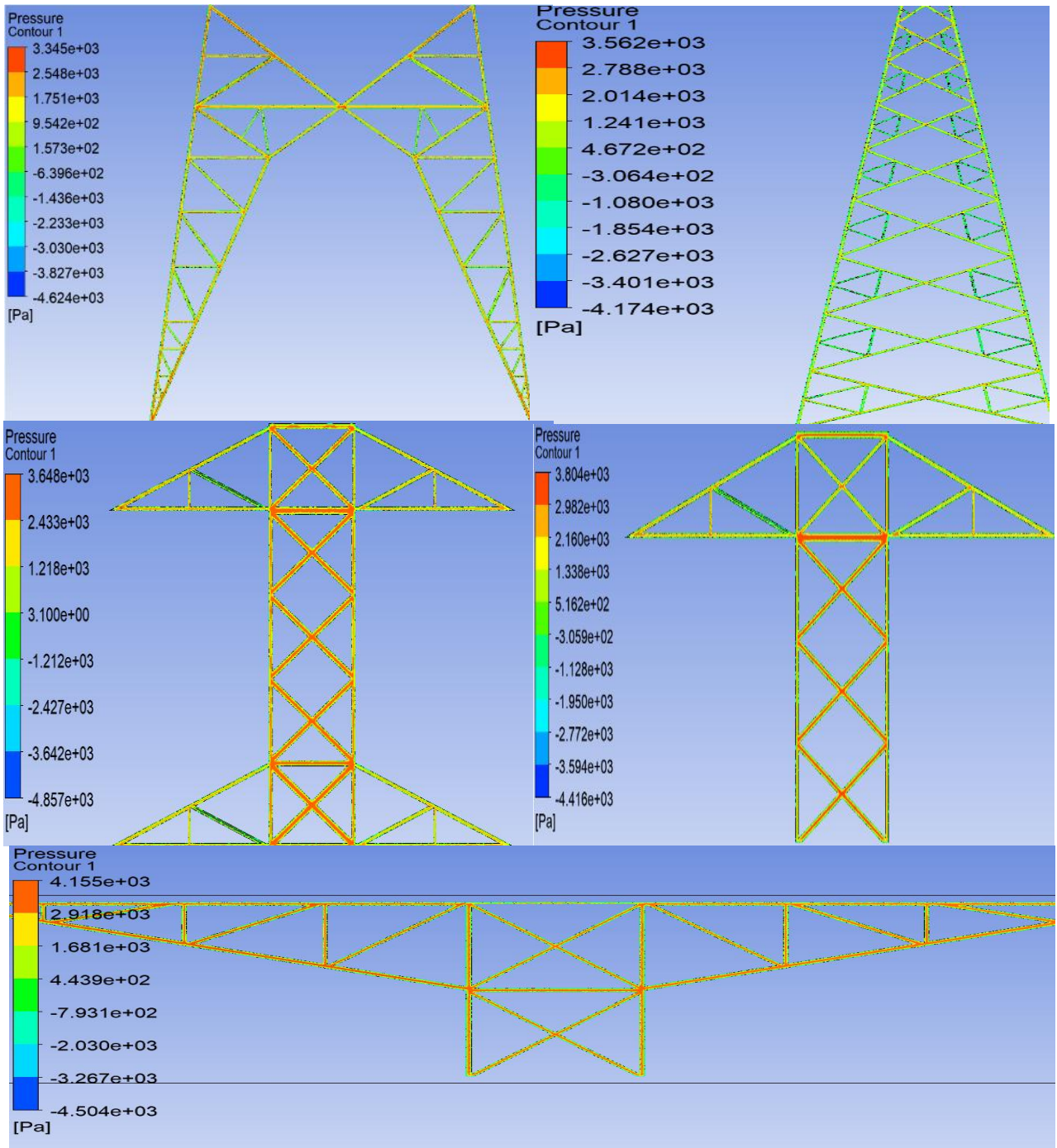

Figure 9 Pressures in the tower divided into 5 segments.

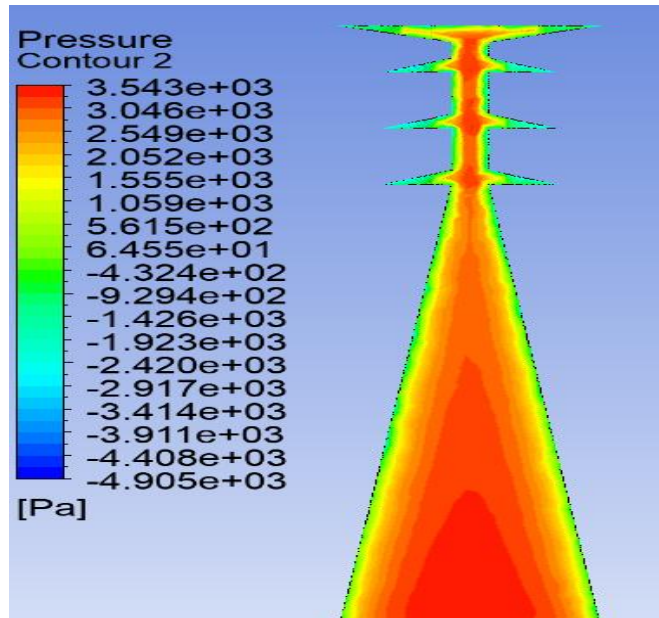

Figure 10 Tower pressures as solid volume.

The following results is the analysis of the tower considering it as a solid volume without distinction of the elements that conform it, so the passage of air does not occur through these elements, it is compared against the pressures obtained with the current regulations in Mexico resulting in a difference of 15% (see table 4).

This model is 6 times shorter in processing time, the model serves only to obtain a generalized pressure but for obtain an aerodynamic behavior close to reality, it is necessary to analyze it as a porous medium in future works.

Table 4 Pressure differences between the MDOC (2020) and the model as a solid volume

Segment	Height (m)	Pressures (Pa) a 90°		% Difference
		MDOC (2020)	CFD	
A	31.07	3064.29	3543.4	15.64

Segment	Height (m)	Pressures (Pa) a 0°		% Difference
		MDOC (2020)	CFD	
A	31.07	3064.29	3519.81	14.87

Figure 11 shows the velocity contour and the streamlines in the upper crosshead of the E71W21 tower, this part of the tower shows the turbulent flow generated by the presentation of vortices where there is a change of velocities in the wind flow, this helps to understand the aerodynamic behavior in this part of the tower in particular. Low-viscosity fluid flow such as air at high velocities is usually turbulent.

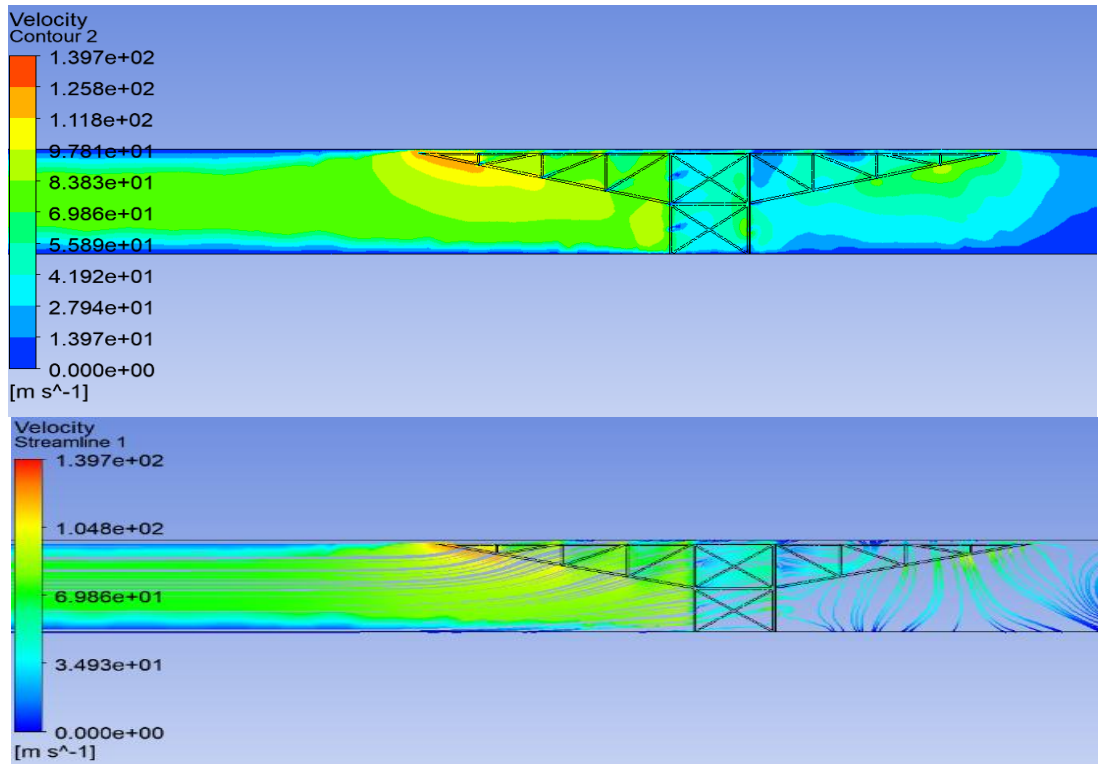

Figure 11 Velocity contour and streamlines on the top crosshead of the tower.

4. CONCLUSION

Computational fluid dynamics is a very useful tool for simulating physical experiments in a wind tunnel, although it cannot replace the need for physical experimentation.

When comparing the simulation results with those obtained according to the current Mexican regulations such as the civil works design manual (2020), it was found that the wind pressure values are 15-20% higher in the CFD model.

Differences in pressures between current regulations in Mexico and CFD may be due to non-simulated factors such as topography and roughness factors. These could be considered in a scaled wind tunnel, although, subdividing the tower reduces the computational cost, could involve differences.

Also, the difference can be presented by the mesh quality, turbulence model used, or simplifications by the need to reduce the computational cost, since the processing time per tower segment ranged from 6 to 8 hours.

It is possible to observe the presence of turbulent flow in the crossarms of electrical transmission towers, generated by the formation of vortices due to changes in wind speed. This phenomenon is useful for understanding the aerodynamic behavior of towers and its implications.

The option of modeling the tower as a solid volume is adequate to obtain the general pressure, but it does not allow visualization of streamlines and vortex behavior, which causes higher suction on the leeward side at the bottom of the tower and the drag coefficients could not be correct.

Recommendations for future research are:

1. Evaluate the CFD models with different turbulence models, analyze which gives better results in processing time and better residual values in the convergence of the solution.
2. Compare the results of the CFD model against a wind tunnel simulating ground and transmission tower conditions.
3. Change in the standards in Mexico to evaluate the transmission tower with a return period greater than 50 years, the regional wind speed for this return period has been exceeded in recent hurricanes that have impacted the country.
4. Calculate an elastoplastic analysis to know the collapse mechanism of the structure.
5. Evaluate the tower as a porous medium with the objective to reduce the computational cost, although to determine the pressure drop, the initial resistance and permeability factor needs to be known, physical experimental support is required for the different tower geometries to be analyzed.

REFERENCES

- [1] D. Murià Vila *et al.*, *El huracán Odile y sus efectos en la infraestructura del sur de la península de Baja California*. México, DF: Universidad Autónoma de México, 2015.
- [2] N. M. García Arróliga, K. M. Méndez Estrada, S. Nava Sánchez, and F. Vázquez Bravo, "Impacto socioeconómico de los principales desastres ocurridos en la república mexicana en 2014," Ciudad de México, 2016.
- [3] Y. A. Çengel and J. M. Cimbala, *Mecánica de fluidos*. México, DF: McGraw-Hill, 2006.
- [4] C. L. Jiyuan Tu, Guan-Heng Yeoh, *Computational Fluid Dynamics: A Practical Approach*, Third., vol. 53, no. 9. United Kingdom: Elsevier, 2018.
- [5] S. Chitra Ganapathi, P. Harikrishna, and N. R. Iyer, "Numerical investigations of aerodynamic forces on 2-D square lattice tower section using two-equation turbulence models," *Proc. 8th Asia-Pacific Conf. Wind Eng. APCWE 2013*, vol. 150, pp. 640–649, 2013.
- [6] A. Costa, F. Paiva, and R. Barros, "Aerodynamic Study of Wind Flow through a Lattice Tower of Angular Section Profiles , Using Computational Fluid Dynamics," *Proc. 2014 Int. Conf. Mech. Civ. Eng.*, pp. 83–87, 2014.
- [7] P. S. Oza, M. Kumar, and P. K. Mohapatra, "Aerodynamic forces on a high-voltage delta-configuration lattice transmission tower segment," *J. Wind Eng. Ind. Aerodyn.*, vol. 216, 2021.
- [8] Ya'nán Tang *et al.*, "Evaluation of wind loads on square transmission towers with angle members under skewed winds," *J. Wind Eng. Ind. Aerodyn.*, vol. 229, 2022.
- [9] J. Allegrini, J. Maesschalck, G. Alessi, G. Glabeke, and J. Christophe, "Porous and geometry-resolved CFD modelling of a lattice transmission tower validated by drag force and flow field measurements," *Eng. Struct.*, vol. 168, pp. 462–472, 2018.
- [10] M. L. Pezo, N. S. Mirkov, and V. V. Bakic, "Determination of the drag coefficient of lattice structures under wind loading using porous media approach," *Therm. Sci.* 2021, pp. 233–245, 2021.
- [11] Comisión Federal de Electricidad, *Torres para líneas de transmisión y subtransmisión y subtransmisión de 69 kV y mayores*. México, D.F., 2019, p. 46.
- [12] Comisión Federal de Electricidad, *Diseño por viento capítulo C.1.4*. México, DF: Comisión Federal de Electricidad, 2020.
- [13] J. Franke, A. Hellsten, H. Schlünzen, and B. Carissimo, *Best practice guideline for the CFD simulation of flows in the urban environment*, vol. 44, no. May. Hamburg, Germany: COST Office, 2007.

- [14] Y. Tominaga, A. Mochida, and R. Yoshie, "AIJ guidelines for practical applications of CFD to pedestrian wind environment around buildings," *ELSEVIER*, vol. 96, pp. 1749–1761, 2008

UNDER PEER REVIEW