

Original Research Article

Numerical Design of an off-Grid Wind Energy Systems for Small Scale Residential Power Supply

Abstract

The socio-economic developments of all nations depend duly on electrical energy supply. Nigeria as a country is faced with challenges of poor electric power supply due to the challenges from the power holding company of Nigeria (PHCN) which have left many households and isolated areas with no access to electricity. The fact that fossil fuel generators contributes to climate changes, renewable energy such as wind could be the best alternative. This paper presents the numerical design of an off-grid wind energy systems for powering load demand of two bedrooms apartment. The load demand of two bedroom flats were estimated and sizes of wind turbine, storage batteries and inverter with respect to typical load demand were numerically estimated. The performance of three 1 KW horizontal axis wind turbines of the same capacity but from different manufacturers namely; Bergey's (BWC XL.1), Wind energy (WE.7) and Hummer wind energy (H3.1) were numerically tested using the average monthly wind speed data of Aliero Kebbi state, Nigeria. The result shows that integrating 1 kW wind turbine with 6 pieces of 200 Ah batteries on 24 V system and 1 kVA inverter would be feasible for 505 W (4.37 kWh/day) load demand with two days autonomy. The annual mean energy generated by the BWC XL.1, WE.7 and H3.1 using annual mean wind speed 5.03 m/s were 1782 kWh/yr, 1451kWh/yr and 1909 kWh/yr, attaining efficiencies of 44.45 % 33.22 % and 33.22 % respectively. Based on these results, BWC XL.1 could be best alternative wind turbine for the location because of its optimum efficiency. In addition, its energy generation of 1782 kWh/yr is 11.72% greater than 1595 kWh/year, the typical residential household load demand.

Key Words: Wind Speed, Wind turbine, Load demand, Renewable Energy

1.0 Introduction

Electrical energy is needed for socio-economic development in both rural and urban areas. The residences of some rural areas are not connected with national grid due to some economic reasons. However, due to the rapid increase of population in Nigeria and some shortcomings from the Power Holding Companies which created large barrier between power generation capacity and energy demand, the power supply in the urban settlements is not stable and reliable for domestic and industrial use. This attracted attention of many people towards utilization of fossil fuel generators for alternative use. The combustion of fossil fuels is not economical and can contribute to climate changes. Renewable energy technology have attracts attention of many nations due to the negative effects of fossil fuels to the environment, and its contribution to global warming and climate change. Wind and solar energy, as the most abundant renewable energy sources, are periodically and seasonally intermittent. An essential feature of most renewable energy sources is their intermittency that conflicts with reliability of electricity supply (Robert and Lorena, 2011). Renewable energy systems based on intermittent sources exhibit strong short – term and seasonal variations in their energy outputs (Shakya *et al.*, 2005).

1.1 Wind Turbines

Wind turbine captures the wind power available in its swept area and converts into electricity. The wind power driven stand-alone systems have becomes one of the most promising way to overcome the electricity demand of several off-grid consumers worldwide (Erkan, 2011). Neither a solar nor a wind energy system alone can fully satisfy load consumption because of seasonal and periodic climatic variations. Energy storage technology is very essential for proper utilization of wind powered renewable energy stand-alone systems and it could only be stored if the generated power is greater than the load demand. Many batteries might be used because of its short term storage and its associated problems of energy loss, limited life cycle, depth of discharge and replacement. However, at high peak of generation, batteries might become fully charged under load condition and the surplus might be diverted to auxiliary load.

A wind energy system comprises a wind turbine, charge controller, storage batteries and inverter to serve a particular load demand. This research entailed estimation of wind energy system components sizing using numerical equations and investigation of the techno-economic feasibility of the configuration of wind energy system for stand-alone application in Aliero. Based on the load demand, energy resources of the location and cost implication of the system.

The Figure 1 shows a block diagram of the stand-alone wind energy system. The wind turbine generates AC electricity; the AC/DC charge controller controls the charging of batteries, the batteries stores energy and feed the load when needed through the DC/AC inverter,

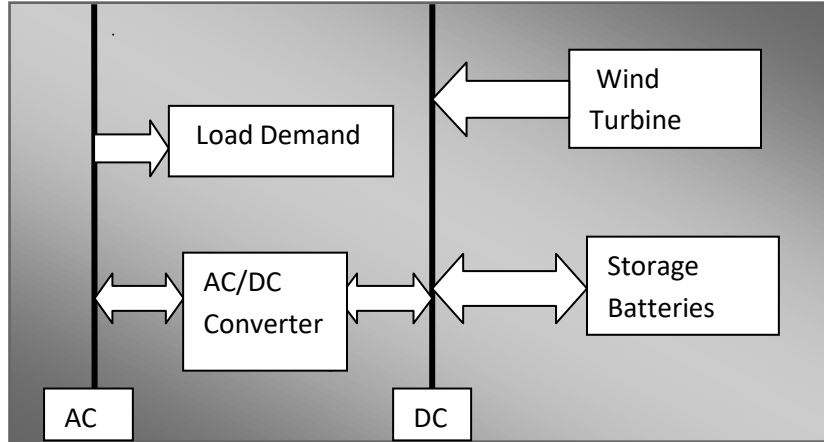

Figure1: Block Diagram of Stand-alone Wind Energy System

Wind energy can be captured, harnessed and converted to electricity by wind turbines. The magnitude of electricity generation depends on the intensity of wind speed and technical specifications of the turbine. Wind energy conversion and applications researches in the world have been rapidly increasing, so the efficiency of wind energy implementations has theoretically reached the maximum benefit of 59.3% according to the Betz Limit. Today, available wind energy ratio reaches about 40-45% in average, with modern types of wind turbines (Akyuz, *et al.*, 2012).

Energy efficiency investigation is a crucial issue for designing a stand- alone energy system. The turbine coefficient of power (C_p), gear box η_{gb} , and generator η_g efficiencies for small scale wind turbine (1kW to 100kW), ranges from 20 - 40%, 70 - 80% and 60 - 80% respectively (Shepherd, 2007). Bergey Wind power's 1 kW (BWC XL1) is a good example of the conventional three bladed upwind horizontal axis wind turbine (HAWT), which was the predominant configuration at the market survey. The rotor blades are 2.5 m diameter protruded fiberglass, the over speed control is passive furling, the yaw control is via the wind vane, and the tower is tubular steel tilt-up. Figure 2 shows a horizontal BWC XL.1 turbine.

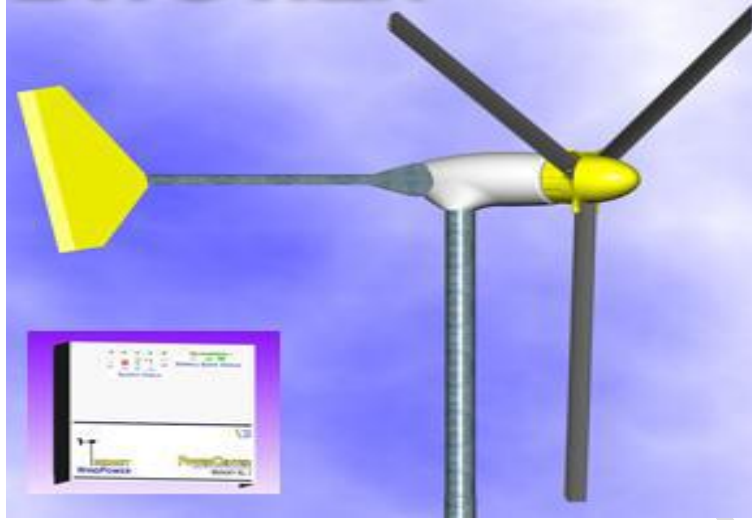

Figure 2: BWC XL.1 Wind Turbine (Bergey Wind power. Co 2010)

The power laws can be used to extrapolate the average monthly wind speed data measured at anemometer height to different hub height of the turbines by using equation 1

$$\frac{V_2}{V_1} = \left[\frac{H_2}{H_1} \right]^\alpha \quad (1)$$

Where

V_1 is the original wind speed

H_1 the original height,

V_2 is the reference wind speed

H_2 is the reference height and

α the coefficient of wind power given as 1/7 (0.1428) (Caisheng and Hashem, 2008).

Wind turbine choice is necessary due to the unpredictable nature of wind speed. The wind turbine adequate sizing with respect to load is very essential, the sizes of the turbines for a specific load demand could be determined by using equation 2 (Mehmed *et al.*, 2011). The fact that the total energy generation should be equals or greater than the load demand. Energy deficits would be observed if the load demand is greater than the generation, while excess energy is observed when the generation is greater than the load. The size of the wind turbine could be calculated using equation 2

$$P_{wt} = \frac{P_{ed}(W)}{\eta_{wt}\eta_{bt}\eta_{in}} \quad (2)$$

Where P_{wt} is the rated wind power, P_{ed} is the electric power demand and η_{wt}, η_{bt} and η_{in} are efficiencies of wind turbine, batteries and inverter, respectively. The wind power available, and

the wind energy turbine output could be modeled by equation 3 and 4 (Shepherd, 2007, Hamane *et al.*, 2010).

$$P_{av} = \frac{1}{2} \rho A V^3 \text{ (kW)} \quad (3)$$

$$E_{wn} = \frac{1}{2} \rho A V^3 C_p \eta_g \eta_{gb} \text{ (kW)} \quad (4)$$

Where:

P_{av} is the power available,

E_{wn} is the wind energy output and

ρ is the air density (kg/m^3),

A is the turbine cross-sectional area (m^2),

V the wind speed (m/s) and C_p , η_{gb} and η_g are the turbine, gear box and generator efficiencies respectively.

1.2 Load Demand

Load demand profile determines the number of electrical components desired to be powered by electrical power system in a particular household. The electrical energy consumption in kWh/day from a typical household in a study area is necessary for adequate component sizing and efficient power supply from the source to the load. Dabai *et al.*, (2012) and Mehmed *et al.*, (2011) used equation 5 for estimation of total energy demand.

$$E_{ed} = \sum_{i=1}^n I_n V_n D_n \quad (5)$$

Where $I_n, V_n = P_{ed}$ and D_n are total power demand and duty cycle of each electrical appliance in a house hold.

The Batteries are essentially required for short term energy storage due to fluctuation nature of wind energy. The capacity and number of the required batteries for the system could be determined by using equation 6 and 7 adopted by (Mehmed *et al.*, 2011).

$$Ih = \frac{\alpha E_{ed}}{\eta_s V_s (1 - SOC_m / 100)} \quad (6)$$

Where Ih is the required power capacity of the battery, V_s is the voltage supply, SOC_m is the minimum state of charge of the battery and α the days of autonomy, η_s system efficiency

$$N_B = \frac{Ih(Ah)}{B_R(Ah)} \quad (7)$$

Where B_R is the rating of battery in (Ah) and (N_B) is the number of batteries required for the system operation

The Inverter is an electronic device that converts the direct energy supply DC to alternating current AC for interfacing wind energy system. To determine the size of inverter for the system, the total load power and nominal efficiencies could be used in equation 8 (Dabai *et al.*, 2012).

$$INV_R = \frac{P_{ed}(W)}{\eta_i \eta_w} + 25\%P_{ed} \quad (8)$$

Where η_w is Efficiency of wiring, η_i is inverter efficiency and $P_{ed}(W)$ is power demand.

The numerical system design by using physical equations has enormous importance, because it determines the accurate sizes of the electrical components required to serve the load demand of the individual households.

2.0 Methodology

In order to numerically design a wind energy system for any suitable location, the wind speed data of the location, and a survey on load demand are mostly required. These parameters were essentially used for the estimation of wind turbine, inverter and battery bank sizes. The study was conducted at the Kebbi State University of Science and Technology, Aliero, located in Kebbi State latitude 12.2737 and longitude 4.451

2.1 Wind Speed dataset

The renewable energy resource used in this research is wind speed. The daily average wind speed dataset for the year 2016 collected from Meteorological Centre in KSUSTA at Faculty of Agriculture was used for numerical estimation of wind power potential. While the average monthly wind speed was deducted from the daily average dataset. Table 1 shows the average monthly wind speed data of Aliero.

Table 1: Monthly Average Wind Speed of Aliero for the year 2016

Month	Average wind speed (m/s)
January	7.13
February	5.99
March	5.55
April	4.51
May	4.44
June	5.64
July	4.97
August	4.35
September	3.64
October	3.74
November	4.78
December	5.64
Ann. Mean	5.03

The load demand of two bedroom flat at Aliero town was obtained by conducting a survey to identify energy consumption in a typical off-grid. This was achieved by identifying the number of electrical appliances commonly used by a typical electrical consumer. The summary of the residential load requirement is presented in Table 2.

The total load demand is calculated to be 505 W. However, depending on the daily hours of operating every component, the energy consumption of the household is estimated as 4370 Wh/day with 960 W peak as shown in Table 2. However the energy demand of 4370Wh is interpreted as 1595.05 kWh /yr by the relation using equation 5:

$$\begin{aligned}
 E_{ed} &= \frac{4370 \text{ Wh}}{1000 * \text{day}} * \frac{365 \text{ days}}{\text{year}} \\
 &= 1595 \text{ kWh/yr}
 \end{aligned}$$

Table 2: Summary of the Residential load requirements

S/N	Location	Electrical appliances	No. of Units	Power Rating (W)	Total Power (W)	Daily use (hr)	Daily Energy Use (Wh/day)
1	Outside	Florescent	2	40	80	12	960
		Florescent	2	20	40	6	240
2	Bedroom	Ceiling Fan	2	50	100	8	800
		Florescent	2	40	80	6	240
3	Sitting room	Ceiling Fan	1	50	50	8	400
		Television	1	70	70	12	840
		Decoder	1	30	30	12	360
		Refrigerator	1	85	85	6	510
		Disco light	1	10	10	2	20
Total					$P_{ed} = 505 \text{ W}$		$E_{ed} = 4370 \text{ Wh/day}$

The size of the wind turbine is obtained by using the wiring efficiency, batteries efficiency and inverter efficiency from Table 4 and the power (P_{wt}) load demand of two bedroom flat in Aliero is calculated using equation 2 to be $1184.3 \text{ KW} \approx 1.2 \text{ kW}$.

Due to the fact that different turbines from different manufacturers have different specifications, they might perform differently at the same location. In this study, three different 1 kW wind turbines from Bergey Wind BWC XL.1, Wind Energy7 WE7 and Hummer Wind Energy H31 were considered. The technical specifications of these proposed turbines are shown in Table 3. Moreover, the constants parameters used in numerical equations for the estimation of the component sizes and wind energy potentials are shown in Table 4.

Table 3: Technical Specifications of Wind turbines

Wind turbine model	Rated power(w)	Cut in wind speed (m/s)	Rated wind speed (m/s)	Rotor diameter (m)	Swept area (m^2)
BWC XL1	1000	2.5	11	2.5	4.9
WE7	1000	2	9	2.7	5.7
H 3.1	1000	3	10	3.1	7.5

Table 4: Wind Energy System Efficiency and constants values as they are used in this research

Constant	symbol	Value
Efficiency of wind turbine	C_p	59.23%
Efficiency of the battery	η_{bt}	80%
Efficiency of inverter	η_{in}	90%
Air density	ρ_a	1.23Kg/m ³
Minimum battery state of charge	SOC_m	50%
Wiring efficiency	η_w	80%
Days of autonomy	α	2 days
System Voltage	V_s	24 V
Efficiency of gear box	η_{gb}	70% - 80%
Efficiency of generator	η_g	60% - 80%

2.2 Estimation of Available and Extractible power and Efficiency

The power available and extractible from each of the three different wind turbine were calculated presented for the case of the month of January. Equation 2 was used to calculate the power available (P_{av}), (W) for the three different wind turbines as follows;

The power available (P_{av}), (W) in a swept area 4.9 m² of a three bladed 1 kW, BWC XL.1 wind turbines can be calculated using equation 3. Using the available average wind speed data of 7.13 m/s in January the power available is calculated in *kWh/year* to be 9599.617 *kWh/year*

Then for a three bladed WE.7 Horizontal wind turbines, the power available in its swept area of 5.7 m² using 7.13 m/s average monthly wind speed of Aliero in January is estimated also using equation 3 the power available is calculated in *kWh/year* to be 11166.902 *kWh/year*.

Moreover, the power available in a swept area 7.5 m² of three bladed H3.1 horizontal wind turbines using average monthly wind speed of 7.13 m/s for January in Aliero is estimated using same equation 3 where the power available is calculated in *kWh/year* to be 14693.292 *kWh/year*.

This procedure was applied for estimation of power available in the swept area of the three respective wind turbines from February, to December. However, the annual mean of power available in each turbine is estimated and compared.

On the other hand the power extractible by the turbines was estimated using equation 4, by which in January with monthly average wind speed of 7.13 m/s, the BWC XL.1 having 4.9 m² swept area, without gear box is calculated to be $E_{win} = 4555.578 \text{ kWh/year}$.

While the electrical energy generated by the WE.7 wind turbines with 5.7 m² swept area by January with monthly average wind speed of 7.13 m/s is estimated using the same equation 4 at 80% and 70% as efficiencies of generator and gear box. it was calculated to be $E_{wn} = 3709.56 \text{ kWh/year}$.

Furthermore, the electrical energy generated by the H3.1 wind turbines with 7.5 m² swept area by January with monthly average wind speed of 7.13 m/s is estimated using the same equation 4 using 80% and 70% as efficiencies of generator and gear box is also calculated to be $E_{wn} = 4880.99 \text{ kWh/year}$

The same procedures were applied for the month of February to December. The average annual powers generated by the three different turbines estimated were compared.

The Power efficiency as the ratio of power output to input is hereby determined as the ration of power extractable by the generator to the power available in its swept area. The efficiencies of BWC XL.1, WE.7 and H3.1 three bladed horizontal wind turbines are evaluated using equation 9:

$$\eta_{wt} = \frac{\frac{1}{2}\rho AV^3 C_p \eta_g \eta_{gb}}{\frac{1}{2}\rho AV^3} \quad (9)$$

From equation (9) the efficiency for all the three wind turbines were calculated for the month of January. From the calculations, the efficiency of BWC XL.1, WE.7, and H3.1 wind turbines is calculated to be 47.45 %, 33.22 % and 33.22 % respectively.

The same procedures were applied for evaluation of efficiencies of wind turbines with respect to wind speed data from February, to December. The average annual efficiencies were compared.

3.0 Results and Discussions

The results summery of the estimated components sizing for wind energy system in Aliero is shown in Table 5.

Table 5: Summary of system components sizes

Components	Specification	Quantity
Load demand	505W	
Wind Turbine	1Kw	1
Storage Batteries	200Ah, 24V	6
Inverter	1kVA, 24V	1

The results from Table 5 shows the acceptable sizes of the wind turbine, storage batteries, and inverter that can serve exactly 4370 Wh/day (4.370 kWh /day), 505 W load demands of typical two bedrooms flat at 960 W peaks which is the same as 1595.05 kWh /yr. The size of the turbine which is 1 kW can suitably satisfy the load demand. The size of the inverter was estimated at 826 VA but due to market availability, 1 kVA is considered. This indicated that with the load demand less than the capacity of the wind turbine and inverter, the system would have stable operation towards enhancing sustainable power supply.

Energy storage is essential parameter for operating wind energy system. The results of components specifications from Table 5 revealed that 6 number of 12V; 200Ah deep storage batteries are desirable for the designed wind energy system. This indicated that for the proposed 24V system, 2 batteries should be connected in series and 3 in parallel through 24 V in built charge controller of the wind turbine. This gives 14.4 kWh stored by the batteries which is three times greater than 4.37 kWh /day the load demand, indicating that the stored energy would serve the load for 3 days in the absence of wind speed.

The graph of average monthly variation of wind speed against months in a year is presented in Figure 3. The graph is interpreted by dividing the year into winter and summer months. The winter months include November, December, January, February, March and April. While the summer months are May, June, July, August, September and October. The result shows that maximum average monthly wind speed of 7.13 m/s was obtained in January which is a winter month, while minimum average monthly wind speed of 3.64 m/s was obtained in September which is in summer season. This indicates that high wind speed was observed in winter season compared to summer season in Aliero. This is because the sub-Sahara region where Aliero is located experiences high wind speed during harmatan season than in rainy season.

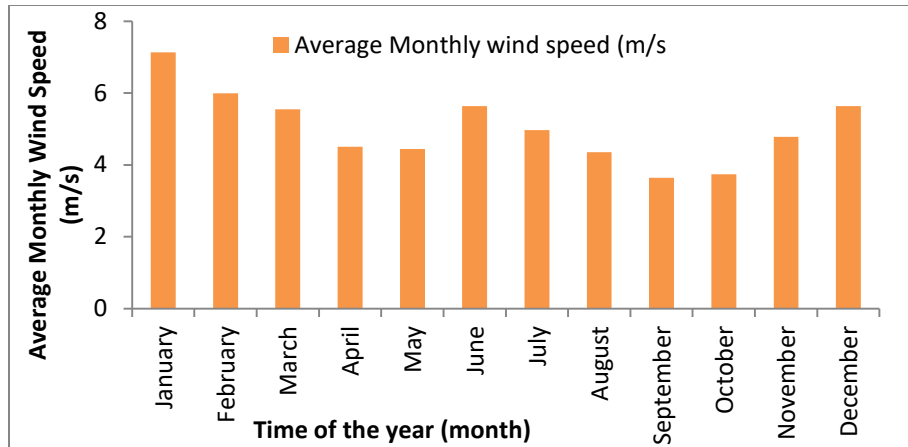

Figure 3: is a graph representation of power available in a swept area which is the same power input to BWC XL.1, WE7 and H3.1 wind turbines against average monthly wind speed of the location. The result shows that in winter season, peak wind speed of 7.13 m/s was observed in January at which BWC XL.1 delivers 9599.62 kWh/yr, WE.7 delivers 11166.9 kWh/yr and H3.1delivers 14693.33 kWh/yr for electrical power generation. However, in this same season, low wind speeds of 4.5 m/s was observed in April, which has been captured by the respective turbines to delivers 2429.49 kWh /yr, 2816 kWh/yr and 3718.6 kWh /yr for power generation. Meanwhile, in June a summer month, the BWC.XL.1, WE.7 and H3.1wind turbines harnessed maximum wind speed of 5.64 m/s and delivers 4751.41 kWh /yr, 5527.2 kWh/yr and 7272.6 kWh/yr respectively to turbine generators for power production. It has also been shown that in September a summer month, low wind speed of 3.6 m/s has been harnessed by the respective wind turbines to deliver 1277.29 kWh /yr, 1485.8 kWh /yr and 1955 kWh/yr for electrical power generation. These indicated that the both turbines harnesses more wind speed available in winter than in summer months which cause more power delivering to the generators. However, H3.1 delivers more power in both winter and summer months than the BWC xL.1 and WE.7 wind turbines. Thus the power available in the wind turbine depends duly on the intensity of wind speed. The result has also indicated that the power inputs flows the same trends with monthly variation of wind speed. However the H3.1 turbine obtained greater value of power input because its swept area is greater than that of BWC.XL.1 and WE.7 turbines.

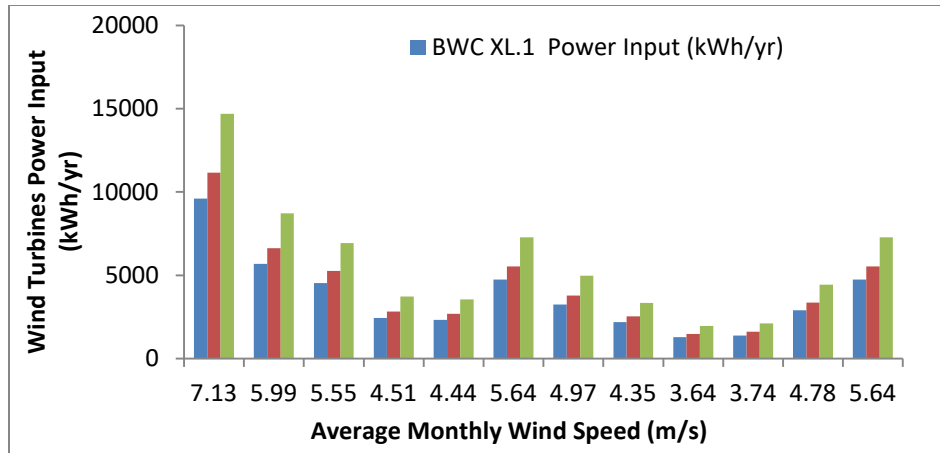

Figure 4: Graph of Wind Turbine Power inputs against Wind Speed

Figure 5 presents graph of power outputs from three different wind turbines against average monthly wind speed. The result shows that at maximum average monthly wind speed of 7.13 m/s in January a winter month, the BWC XL.1, WE.7 and H3.1 wind turbines generates maximum power outputs of 4555.48 kWh /yr, 3709.56 kWh /yr and 4880.99 kWh /yr respectively. In April also a winter month with minimum wind speed of 4.51m/s, these three respective wind turbines generates 1152.91 kWh /yr, 938.83 kWh /yr and 1235.29 kWh /yr. The result has further shows that in June a summer month, with maximum monthly average wind speed of 5.64 m/s, the BWC XL.1 wind turbine generates 2254.77 kWh /yr, WE.7 generates 1836.08 kWh/yr and H3.1 generates 2415.89 kWh/yr. Meanwhile, in September a summer month with minimum monthly average wind speed of 3.6 m/s the BWC XL.1, WE.7 and H3.1 wind turbines generates 606.13 kWh/yr, 493.58kWh/yr and 649.45 kWh/yr respectively. This generally indicates that Both turbines performs better in winter months than in summer months, but the H3.1 wind turbine generates power greater than BWC and WE.7 in every season of the year. Thus the power generates by the turbines is affected directly by the power available which in turns depend on the intensity of wind speed.

The result has further shown that the wind turbines power outputs responded to the fluctuating nature and seasonal variation of wind speed. The H3.1 wind turbine generates power output greater than the BWC and WE.7 because of its large swept area. Although the WE.7 has large swept area compared to BWC wind turbine but the BWC generates more power than the WE.7turbines, because it has no gear box.

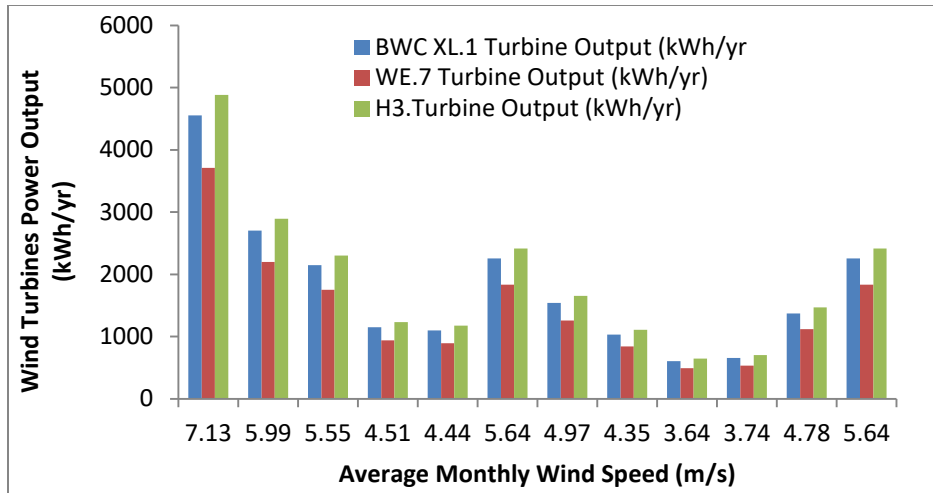

Figure 5: Graph of Wind Turbines Power Output against Wind Speed

Figure 6 presents graph of wind turbines power output against average daily wind speed which determines wind turbines power curves. The power curves of BWC XL.1, WE.7 and H3.1 wind turbines plots are based on the average daily wind speed data for 365 days in a year. The results revealed that BWC, WE.7 and H3.1 turbines have reached their maximum power outputs of 1.35 kW, 1.26 kW and 1.46 kW respectively at wind speed of 10.79 m/s each which are greater the rated output by the manufacturers. It has been observed that both turbines start generation at a wind speed of 2.31m /s which less than their cut in wind speeds. The curves of all the turbines showed good fittings for power generation using the wind speed data of Aliero. Results has further indicated that the wind turbines output have responds to the manufacturers cut-in and rated wind speed and in fact at 10.79 m/s the wind turbines were able to generate 1.35 kW, 1.26 kW and 1.46 kW more than the rated power output of 1 kW by the manufacturers which is an added advantage.

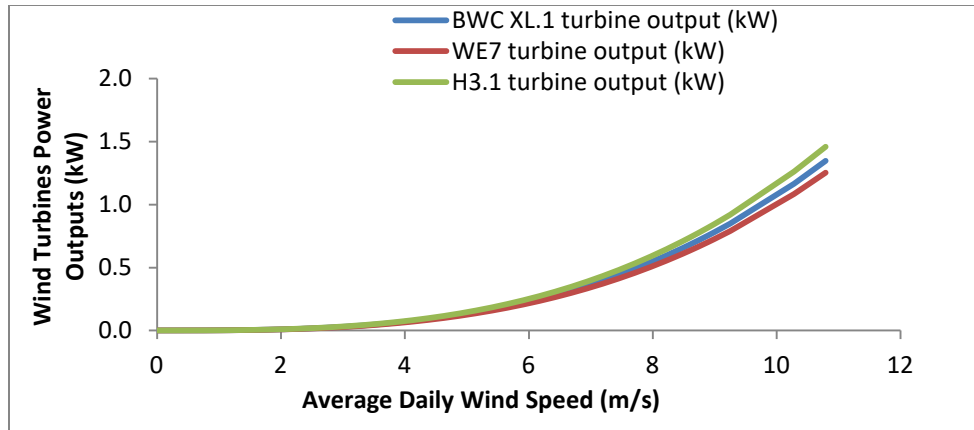

Figure 6: Wind Turbine power output versus Average Daily Wind speed

The results of the annual mean wind speed, the mean power input and output of BWC XL.1, WE.7 and H3.1 wind turbines and their efficiencies are summarized in Table 6.

Table 6: Summary of Mean Wind Speed, Turbines Power input and output and Efficiencies

Wind Turbine	Annual Mean Wind Speed	Mean Wind Power input (kWh/yr)	Mean Wind Power output (kWh/yr)	Wind Turbine Efficiency (%)
BWC XL.1	5.032±1.004	3755	1782	47.45
WE.7	5.032±1.004	4368	1451	33.22
H3.1	5.032±1.004	5747	1909	33.22

The result presented in Table 6 revealed that at annual mean wind speed of (5.032±1.004), the BWC XL.1, WE.7 and H3.1 have captured 3755 kWh/yr, 4368 kWh/yr and 5747 kWh/yr mean power input to generate mean power output of 1782 kWh/yr, 1451 kWh/yr and 1909 kWh/yr respectively. It has also been shown that the turbines have attained efficiencies of 47.45 %, 33.22 % and 33.22 %. This indicates that both turbines attains efficiency within the acceptable limit but the BWC XL.1 has high efficiency compared to WE.7 and H3.1 wind turbines

The result in Table 6 presented the annual mean power outputs and efficiencies of BWC XL.1 WE.7 and H3.1 wind turbines. The result revealed that the annual mean outputs of BWC and H3.1 which are 1782 kWh /yr and 1909 kWh /yr respectively are greater than the load demand 4.37 kWh/day (1595.05 kWh /yr) indicating that both two turbines can serve the desired load. However, considering the efficiencies, the BWC XL.1 has higher value 47.45 % greater than 33.22 % enhances by H3.1. This happens due to the presence of gear box although it has larger

swept area, power input and output. This result agreed with Aderamola and Oyelowo (2011) who obtained 1,561kWh/yr with 7.8 m/s in Sokoto. Therefore, the BWC XL.1 is chosen as suitable wind turbine for Aliero. It has also agreed with Muhammad *et al*, (2013) who reported efficiency of 31.4% for 2.5 kW wind turbine in Sokoto with average wind speed of 5.64 m/s.

4.0 Conclusions

The off-grid wind energy system has been designed using numerical methods. The specifications of wind turbine, storage batteries and inverter for supplying 4.37 kWh /day typical load demand of two bedroom flat in Aliero were determined. The wind energy potential in Aliero with respect to wind speed data has been investigated by choosing BWC XL.1 WE.7 and H3.1 wind turbines which are of the same rating but different specifications. The annual mean power output of 1782 kWh/yr from BWC XL.1 is greater than 1595.05 kWh /yr typical two bedroom load demand in Aliero. Consequently the stored energy in the batteries 14.4 kWh would serve the load of 4.37 kWh /day in three days. The results revealed that Aliero has enough wind potential for harnessing electricity using BWC.XL.1 as the best wind turbine for the location. However, 1 kW BWC XL.1 wind turbine with inbuilt rectifier rated 24 V, could be interconnected with 6, 200 Ah batteries and 1 kVA, 24 V inverter to serve 4.370 kWh/day load for stable and reliable operation of stand-alone off-grid electrical power supply.

References

- Adaramola, M.S. and Oyelowo,O. (2011). Wind Speed Distribution and Characteristics in Nigeria, *Journal of Engineering and Applied Sciences*, **6**, 2 pp 82- 86
- Akyuz, E., Oktay, Z. and Dincer, I. (2012). Performance Investigation of Hydrogen Production from a Hybrid Wind-PV System, *International Journal of Hydrogen Energy*, **37**, 16623-16630.
- Bergey BWC.XL.1 Wind Turbine Manufacturers [online] at www.BergeyWindpower.com
- Caisheng, W. and Heshem, N., M. (2008). Power Management of a Stand-alone Wind/Photovoltaic/Fuel cell Energy System, *IEE Transaction of Energy Conversion*, **23**, 957-967.
- Dabai, K. A., Buda,S. and Yahaya, H. N. (2010). Design of Stand-alone Photovoltaic System for a Typical two Bedroom Flat in Sokoto, *Nigerian Journal of renewable Energy*, **15**. 140 – 145.
- Erkan, D. Bora, A. and Osman, K. (2012). Modeling of Hydrogen Production with a Stand-alone Renewable Hybrid Power System, *International Journal of Hydrogen Energy*, **37**, 3098-3107.

- Hamane, L. A., Belhamel, M., Benyoucef, B., and Hamane, M. (2010). Study of Hydrogen Production from Wind Power in Algeria, *18th World Wind Hydrogen Energy Production Technologies WHEC*.
- Kham, M. J. and Iqbal, M.T. (2005). Pre-Feasibility Study of Stand-alone Hybrid Energy System for Application in Newfoundland, *Renewable Energy*, **30**, pp 835-854
- Mehmed, E., Erkan, D., Suat, S., Junseok, S., Suha, Y. and Osman, K (2011). A mobile Renewable House Using Wind/PV Fuel cell Hybrid Power System, *International Journal of Hydrogen Energy*, **36**, 7985-7992.
- Méziane, F., Khellaf, A., and Chellali, F., (2012). Study and Dimensioning of a Wind-Electrolyzer-Fuel cell System for the Power Supply of an Isolated Site, *Revue des Energies Renouvelables* , **12**, 381 – 391.
- Muhammad, U.K., Umar, S., Musa, M., Garba, M. and Zangina, U. (2013). Utilization of Excess Wind Energy for Electrolytic Hydrogen Production, *International Journal of Engineering Science*, **2**, 28 – 38.
- Roberto, C. and Lorena, G. (2012). Modeling and Optimization of an Energy Generation; Island Base on Renewable Technologies and Hydrogen Storage System, *International Journal of hydrogen Energy*, **37**, 2081 – 2093.
- Shakya, B. D., Aye, L. and Musgrave, P. (2005). Technical Feasibility and Financial Analysis of Hybrid Photovoltaic System with Hydrogen Storage for Cooma, *International Journal of Hydrogen*, **30**, 9 – 20
- Shepherd, W. and Shepherd, D. W. (2007). *Energy Studies*: London, Imperial College Press, 270pp.