

Design and Development of a Cowpea Decorticator

ABSTRACT

ABSTRACT:

Introduction: Cowpea decorticating is a crucial post-harvest process that involves removing the seed coats from the kernels to produce ready-to-use cowpea products such as flour, grits, and protein concentrates and food products such as Akara and Moinmoin in south western Nigeria.

Methodology: In this study, a locally developed cowpea decorticator was tested and evaluated using small oloka (a Nigerian local cowpea breed) cowpea grains. The machine was allowed to run empty for five minutes before the experiment commenced. Three samples of 1kg each were weighed and wetted with same quantity of water for 10, 20, and 30 minutes, respectively. The samples were then fed into the developed decorticator running at a speed of 420 rpm, and the operating speed and time taken were determined using a digital tachometer and stop watch, respectively. Samples of decorticated, undecorticated, and broken cowpea were collected and weighed to evaluate the efficiency of the machine based on the decorticating length and wetting time of cowpea grains.

Results: The study revealed that as the decorticating length increased from 44.5 to 178 mm and wetting time increased from 10 to 30 minutes, the decorticating efficiency increased from 55 to 92.1%. The highest average decorticating efficiency of 92.1% was obtained at 178 mm decorticating length and 30 minutes wetting time.

Conclusion: These findings showed that the decorticating efficiency of the machine depends on the wetting time and the decorticating length of the machine.

Keywords: Cowpea decorticator; Decorticating speed; Soaking time; decorticating efficiency

1. INTRODUCTION

Cowpea (*Vigna unguiculata*) is a widely cultivated leguminous crop that is known as "black-eyed peas" in America and "beans" in Nigeria. It is a significant food source worldwide, providing substantial nutritional and economic benefits. Cowpea is one of the most highly proteinaceous African crops that serve as foods, feeds and fertilizer. It has more calcium than meat, iron content equal to milk and water-soluble vitamins comparable to the levels found in fish and lean meat [1]. Cowpeas are starch-protein seeds with wider pattern of utilization than any other legume in West Africa [2 and 3]. The Cowpea grains are highly rich in lysine and tryptophan amino acids, making them a better dietary option than cereals and root/tuber-based diets of many coastal and forest communities [1 and 4].

In 2020, the global production of dry beans exceeded 35 million metric tons, with Africa contributing over a quarter of the production. Sub-Saharan Africa accounted for around 80% of the continent's total production, with a per capita consumption of approximately 9 kg, which is above the global average. Nigeria is a major producer, accounting for one-third of Africa's total production [2]. Cowpea is consumed in various forms in Nigeria, including as porridge, bean cake, *moin-moin*, and cowpea stew. Common varieties include SAMPEA 10, SAMPEA 8, -0loyin, and Oloka white and brown varieties [5].

Decortications is a crucial and most delicate operation in cowpea processing; it involves the removal of the cortex without tampering or deformed the seed structure. It removes anti-nutritional substances like tannins and phytic acid found in the hulls, improving the digestibility and nutritional quality of cowpea products [6]. It also enhances the taste and texture of cowpea products, making them more appealing to consumers. Additionally, decorticating reduces the volume of material that needs to be processed, promoting efficiency in downstream processing phases like milling and protein extraction [7]. Cowpea products with the hulls removed have a longer shelf life as the hulls can contribute to spoilage by providing a substrate for microorganisms to grow.

In Nigeria and some other sub-Saharan African countries, decorticating and other cowpea processing is done through traditional methods by households or small-scale processors [8 and 6]. This involves water soaking the cowpea at room temperature to facilitate seeds coat removal. The cowpea seeds absorb moisture and swell, the seed coats is then removed by the roughly bruise and stirring action of hand, grinding stone or mortar. These methods are inefficient, time consuming, laborious, damage the cotyledon, low output and at times unhygienic [3]. The lack of efficient method of processing and handling cowpea has limits its use as a staple food product with the desired export quality [9].

Various methods are available for medium to large scale cowpea decorticating, including mechanical, thermal, and enzymatic methods. Abrasive decorticating is commonly used and highly efficient but may cause damage to the cotyledons, resulting in a high percentage of broken or damaged beans [8]. Impact decorticator requires high energy and may be less efficient [10]. Enzymatic dehulling/decortications is a gentle method that uses enzymes to break down the cell walls of the hulls, resulting in high efficiency, but requires specific enzymes and longer processing times [11]. Other methods include milling and boiling or soaking.

The aim of this work is to design, fabricate and evaluate cowpea decorticating machine using the selected machine parameter i.e decorticating distance and selected crop parameter i.e seed soaking time.

2. MATERIAL AND METHODS

Design and development of the cowpea decorticator and its performance evaluation has been carried out at the Food Processing laboratories of Department of Agricultural Engineering, LAUTECH, Ogbomoso, Nigeria (latitude 21.30052° N, longitude 70.26504° E). The machine was designed using Autodesk Inventor (2023) software and fabricated at the departmental workshop.

2.1 Development of the Machine

To ensure effective design of the machine, various physical and mechanical properties of different cowpea varieties were taken into account, including axial dimension, shape, true density, bulk density, and porosity. The selection of materials for construction of the machine was based on a balance between hygiene, cost, strength, and availability.

2.1.1 Decorticating mechanism

The machine utilizes an auger that rotates and creates frictional forces to detach the hulls from the beans. The cowpeas collide with the auger and the decorticating chamber, leading to the separation of the hulls from the cotyledons. To estimate the needed materials, the volume of each component was estimated.

2.1.2 General description of dehuller

The cowpea decorticating machine consist of a fixed metal frame, feeding hopper, decorticating auger, pulley, belt and a petrol engine as shown in Fig 1.

2.1.3 The hopper (feeding unit)

The cowpea decorticating machine's hopper is responsible for feeding the cowpea into the decorticating chamber. The hopper's geometry initiate the material flow rate into the decorticating chamber, and its design is based on the material's mechanical behavior. To determining the proper slanting angle for the hopper, semi-included angle, which is determined experimentally by measuring the coefficient of friction ((Equation 1) [12 and 13], was used. For a steady flow of cowpea seeds during decortications, the outlet dimensions were determined using Beverloo's equation, Equation 2, [14] which has been used by [15 and 13]). The hopper is constructed using 2 mm-thick mild steel plate, chosen for its strength. The detailed hopper view is shown in Fig 2.

$$\Phi = 0.0023\delta^2 - 1.5646\delta + 43.343 \quad (1)$$

$$W = 0.58\rho_b g^{0.5} (B - Kd_p)^{2.5} \quad (2)$$

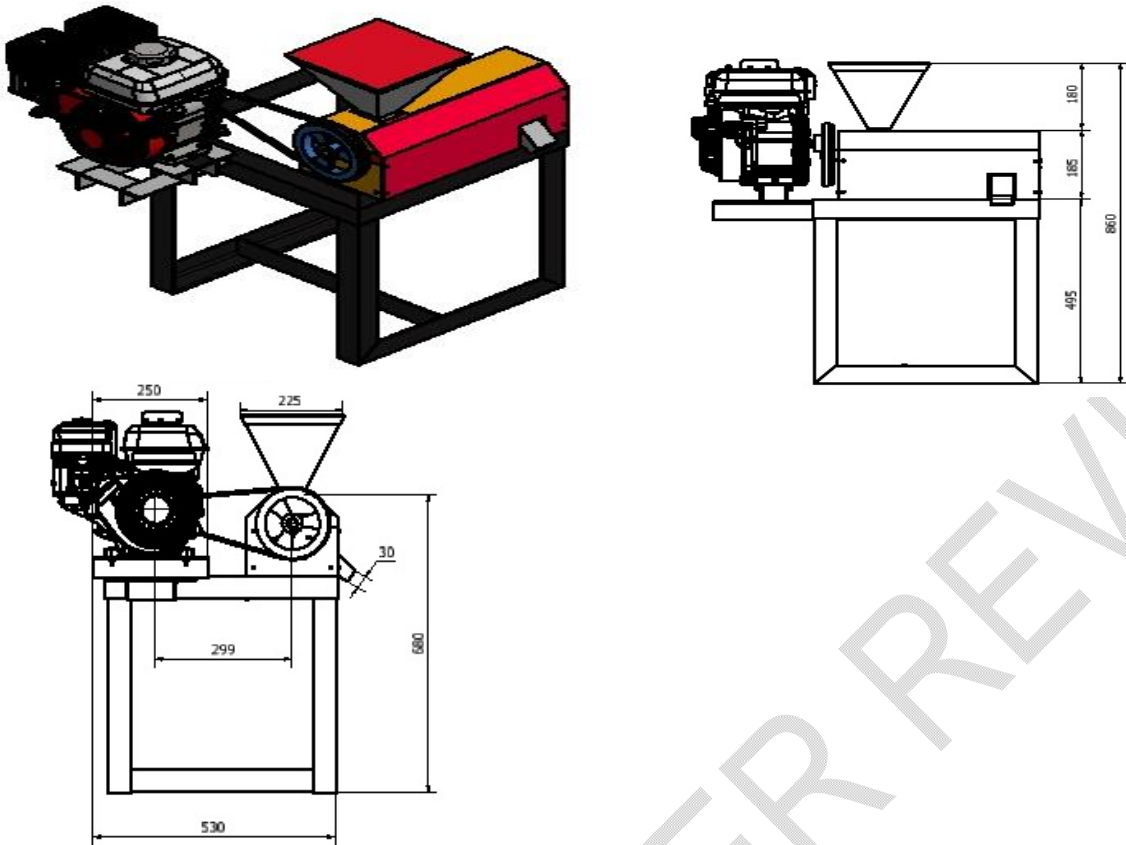

Fig 1: Orthographic view of the cowpea decorticating machine

Where W is discharge rate (kg/sec), ρ_b is bulk density (kg/m^3) and g is gravitational constant, B is outlet size (m) and K is Beveloo constant (typically 1.4) and d_p is particle size (m).

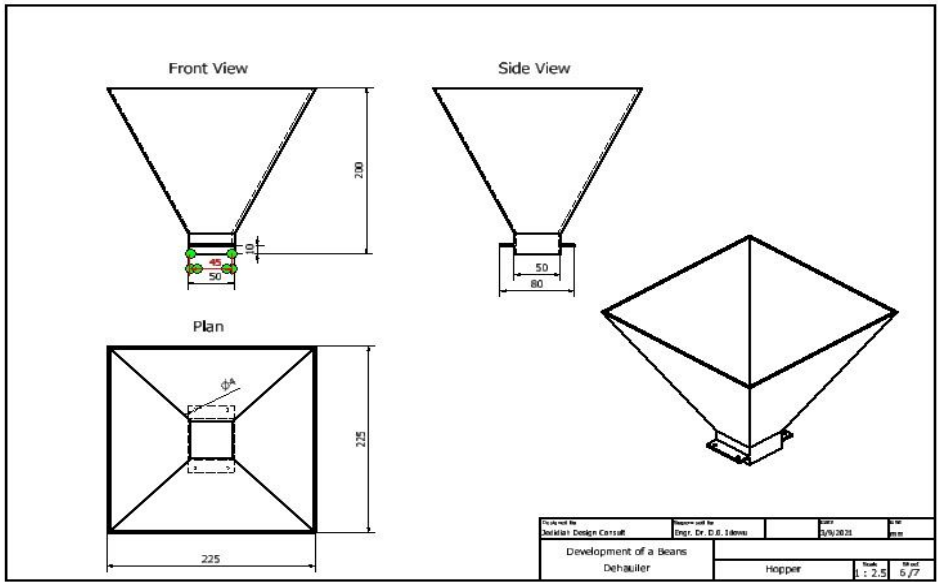

Fig 2: Isometric view of the hopper

2.1.4 Shaft

Fig 3 shows the orthographic view of shaft and pulley decorticating shaft. The spiral structure on the shaft provides the required frictional forces to remove the wet cowpea seed's coat upon the application of sufficient frictional force created by the rotating shaft.

Determination of power requirement for decorticating mechanisms

Equation – shows total power required

$$P_T = P_s + P_{dc} \quad (3)$$

Where P_T is the total power required,

P_s is Power required by the shaft

P_{dc} is Power required for shelling

Maximum torsional moment acting on the shaft,

$$M_t = \frac{P \times 60}{2\pi N} \quad (4)$$

Where M_t the torsional moment and P is is the equivalent

$$\text{Therefore } P = P_s = \frac{M_t \times 2\pi N}{60}$$

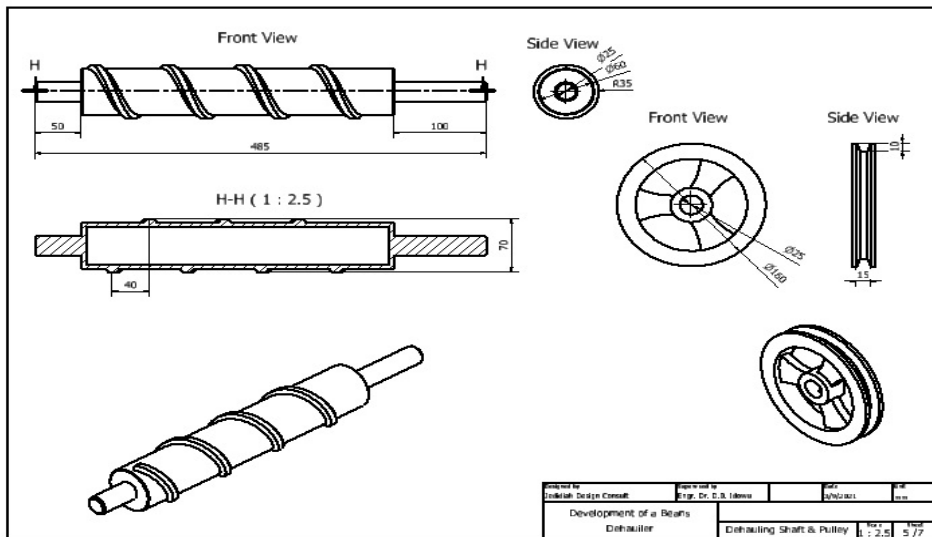

Fig 3: Orthographic view of shaft and pulley

2.1.5 Speed of the decorticating drum

The machine was designed to be powered by gasoline engine, 2.5 Hp at 3600 rpm with max torque 4.5 Hp at 2500 rpm being the lowest gasoline engine in the market was adopted. Using the theory [15] that the product of the diameter and speed of one pulley is equal to that of the other; the speed of the hammer was calculated using Equation 5.

$$D_1 N_1 = D_2 N_2 \quad (5)$$

Where;

N_1 is the speed of the decorticating shaft (rpm),

D_1 is the diameter of the pulley on the petrol engine = 55 mm

D_2 is the diameter of pulley attached to the decorticating shaft

N_2 is the speed of the petrol engine (rpm)

Analysis of the pulley

The total mass of the pulley was calculated using

$$\text{Volume of the pulley (V)} = \pi \left(\frac{D^2}{4} \right) \times t \quad (6)$$

Where D is the diameter of the pulley and t is the thickness of the pulley.

Mass of the pulley was calculated using:

$$\rho_p = \frac{m_p}{V_p} \quad ([17]) \quad (7)$$

Where m_p is the mass of the pulley

V_p is the volume of the pulley and

ρ_p = density of the pulley

2.1.6 Belt size determination

The length of the pulley belt was determined using Equation 8 to determine the centre distance, C, of the two pulley and equation to determine the length of the belt.

$$C = D + 1.5d \quad [17 \text{ and } 13] \quad (8)$$

Where d_{ps} is the diameter of the pulley on the shaft of prime mover and

D_{pt} is the diameter of the pulley on the decorticating shaft

C is the centre distance between the shaft of the decorticating shaft and the shaft of the prime mover.

The length of the belt was then calculated using

$$L = 2C + 1.57(D + d) \frac{(D - d)^2}{4C} \quad [17 \text{ and } 13] \quad (9)$$

Angle of contact was calculated using Equation 10.

$$\theta = \pi - \frac{D - d}{C} \text{ rad} \quad [17 \text{ and } 13] \quad (10)$$

Where:

L is total length of the belt in mm,

D_1 is the diameter of the driving pulley

D_2 is the diameter of the driven pulley

X is the distance between the centres of the two pulleys

θ_p is the contact of the pulley

2.1.7 Decorticating unit

The decorticating unit consists of the decorticating chamber, decorticating shaft and the discharge chute. The decorticating chamber is a horizontal cylindrical drum closed with a circular flange. The unit is split to half, coupled with bolt and nut via the flange at both extreme. The upper half has a central opening of 50 mm extended to the feeding unit (Fig 4). The chamber houses the decorticator, which is a cylindrical shaft with a screw auger for creating frictional force within the cowpea and between the cowpea and the decorticating chamber and also as conveyance. The screw auger with 4 flight rounds, 335 mm long with a screw pitch width of 60 mm and screw depth 10 mm, giving 70 mm outside diameter. The auger is coupled with a pulley to provide the shaft rotation. The discharge chute directs the flow of the cowpea to a receptacle. The chute is a 40 cm by 20 cm cuboid inclined to the bottom of the decorticating chamber at 45°. The mixture of decorticated cowpea and hull is collected via the discharge chute for manual separation.

Weight, volume and area of the decortivating cylinder, W_c , was determined using equation -

$$W_c = \ell g V_c \quad (11)$$

$$V_c = A_c \times L_c \quad (12)$$

$$A_c = \frac{\pi}{4} \times D_c^2 \quad (13)$$

Where,

V_c , is the volume of the decortivating cylinder

ℓ is the density of the cast iron (kg/m^3)

G is the acceleration due to gravity (m/s^2)

V_c is the area of the decortivating cylinder (m^2)

2.1.8 Determination of the capacity of the machine

The capacity of the machine was determine by determine the volume of the seed that the decortivating chamber can accommodate. The decortivating chamber is cylindrical in shape; the volume of the seed (V_{cs}) in the decortivating chamber is obtained by subtracting the volume of shaft (V_s) from the volume of the decortivating chamber as presented in Equation 14 and 15

$$V_{cs} = V_{dc} - V_s \quad (14)$$

$$V_{cs} = \pi L (r_{dc}^2 - r_s^2) \quad (15)$$

Where;

V_{dc} is the volume of the dehulling chamber

V_s is the volume of the shaft

R_{dc} is radius of dehulling chamber (m)

r_s is radius of shaft (m)

l is length of dehulling chamber (m)

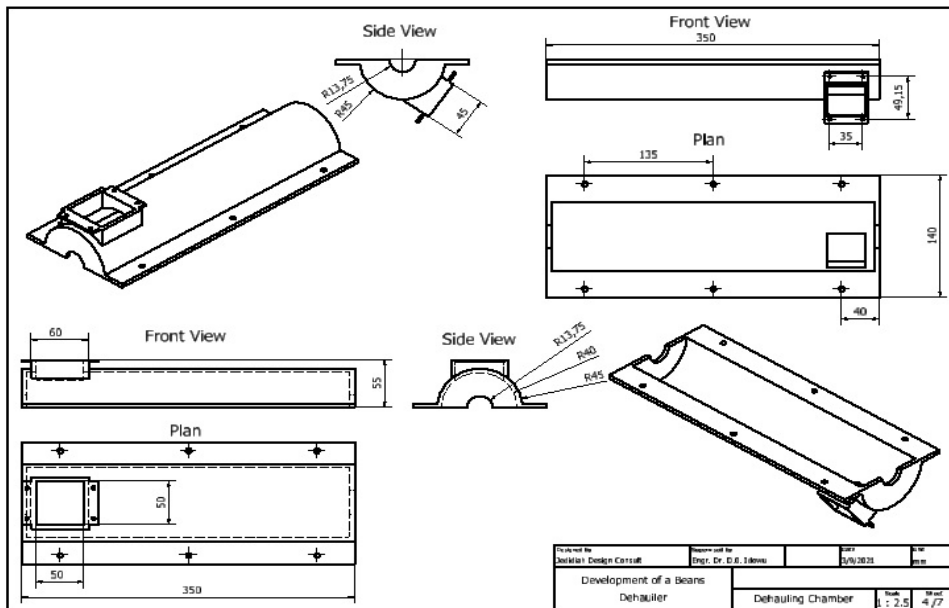

Fig 4: Orthographic view of the decortivating chamber

2.2 Experimental Methodology

The experimental procedure is as reported below.

2.2.1 Sample preparation

The cowpea varieties were sourced from the central market in Ogbomosho. The beans were cleaned, sorted for removing undesirable materials like dust, dirt, stones and immature seeds.

2.2.2 Batch experiment

The cowpea decorticator was allowed to run empty for five minutes when a steady momentum was achieved. Local cowpea grains (small Oloka) were used in testing the performance evaluation of the machine. Bulk sample (10 kg) of the grains was used for testing the machine. A Weighed sub-samples of (1kg) each into three parts which were wetted with the same quantity of water and allowed to wait for 10, 20 and 30 minutes and then fed through the hopper into the machine. The operating speed and time taken was determined by using digital tachometer and stop watch. Samples of decorticated cowpea were collected and weighed. They were then separated into decorticated seeds, undecorticated seeds and broken seeds then weighed respectively.

2.3 Performance Evaluation

The performance evaluation was done as presented below.

2.3.1 Performance indices

The performance indices that were used include; percentage seeds decorticated (%), percentage undecorticated seeds (%), and percentage broken seeds (%) and decortivating efficiency (%). All these were determined using equations 16, 17, 18 and 19 respectively.

2.3.2 Percentage of decorticated seeds - S_D

$$S_D = \frac{W_d}{WT} \times 100\% \quad (16)$$

W_d is Weight of decorticated seeds

S_D is percentage of decorticated seeds

2.3.3 Percentage of undecorticated seeds - S_{UN}

$$S_{UN} = \frac{W_{ud}}{WT} \times 100 \quad (17)$$

S_{UN} is percentage of undecorticated seeds

W_{ud} is weight of undecorticated seeds

2.3.4 Percentage of broken kernel

This was calculated from Equation 10.

$$T_B = \frac{M_C}{M_C + M_B} \times 100 \quad (18)$$

Where:

T_B is percentage broken

M_B is mass of whole cotyledons

M_C is mass of broken cotyledons

Note all decorticated but fractured, changed in form, oppressed or flatten seed were classified as broken [18].

2.3.5 Decortivating efficiency (η_s)

The decortivating efficiency is the ability of the machine to effectively remove the shell of the seed. It was calculated using Equation 10 as reported by [19] and [13].

$$D_{Ef} = \frac{W_d}{W} \times 100 \quad (19)$$

Where D_{Ef} is decortivating efficiency

W_d is weight of decorticated seeds

W is total weight of the sample introduced

The factors that were considered in the evaluation of the decortivating machine were decortivating length and Wetting time. Decortivating length is the distance travel by the cowpea during decortivating. The decortivating machine was evaluated with three decortivating lengths: 44.5, 89, 133.5 and 178 mm. and three wetting time 10, 20 and 30 mins.

2.4 Statistical analysis

The data were analyzed and standardized using the MS- Excel 2010 and ANOVA done by factorial completely randomized design (F-CRD) to describe the dependence of decortivating efficiency on variables studied. Forty eight treatment combinations with three replications were evaluated in this study and the mean values were reported. Means and analysis of variance (ANOVA) were conducted ($p = .05$).

3.0 RESULTS AND DISCUSSION

The results of the experiments is as reported below

3.1 The design and fabricated machine

The cowpea decortivating machine design and fabricated is as shown in (Fig 5).



Fig 5: Cowpea decorticator in operation

3.2.1 Effects of soaking time and decortivating length on percentage of broken cowpea

An effect of soaking time and decortivating length on percentage of broken cowpea is presented in Fig 6. The diagram shows that increasing the decortivating length and soaking time results in a higher percentage of broken cowpea. Although the broken percentage for both parameters varies by less than 3%, it suggests that other factors could be contributing to the breakage. Notably, the differences in broken percentage are more significant between 20 to 30 minutes soaking time compared to 10 to 20 minutes soaking time. Additionally, the longest shaft length (178 mm) has a considerably higher broken percentage than the first three shaft lengths (44.5, 89, and 133 mm). These results imply that longer decortivating length and soaking time may increase the risk of cowpea breakage due to the brittle or fragile nature of the kernel at higher moisture content. Longer decortivating length also result in larger centrifugal force acting on the fragile kernel, causing more breakage [10]. Therefore, it is essential to carefully consider the decortivating length and soaking time to achieve optimal results with minimal breakage.

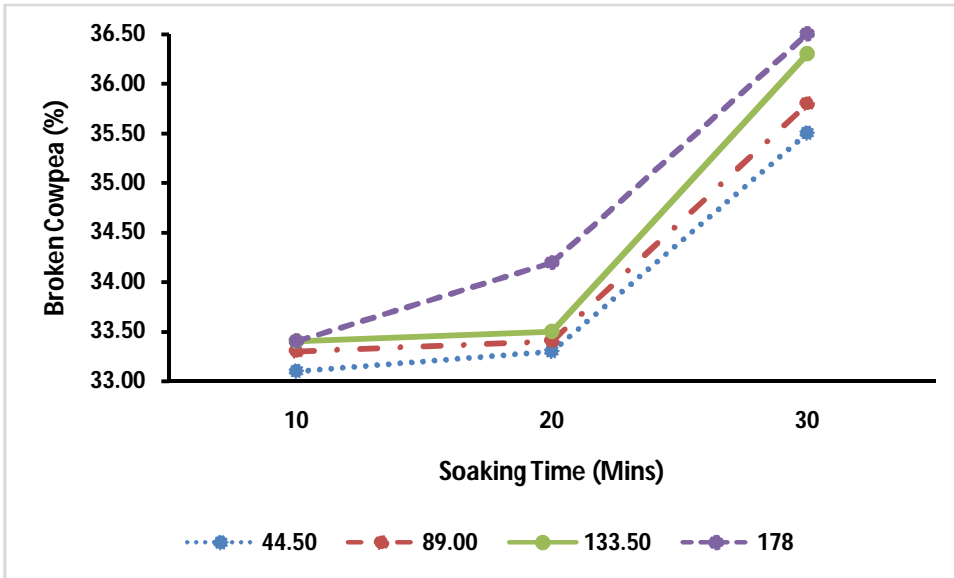

Fig 6: Effect of soaking time and decortivating length on cowpea breakage

3.2.2 Effects of Soaking Time and Decortivating Length on Decortivating Efficiency

The effects of soaking time and decortivating length on decortivating efficiency is as presented in Fig 7. The percentage of seed coat removed during processing is an indication of the efficiency of the machine. It was observed that as the soaking time and decortivating length increased the efficiency also increased. The highest efficiency of 92.1% was achieved at 30 minutes of soaking time and 178 mm of decortivating length. This trend is in agreement with previous studies by [5 and 10] who reported that longer residence time offered by longer decortivating length and low speed allowed the soaked cowpea seeds to rub against each other and the wall of the decortivating chamber, resulting in increase in decortivating efficiency.

However, it should be noted that longer soaking times may lead to a greater difference in moisture content between the coat and the cotyledon, resulting in a softer cotyledon that is easily broken. This finding is agreement with the studies of [8] who reported that excessively long soaking times could result in undesirable outcomes such as seed breakage. The result shows that the best soaking time is 20 minutes.

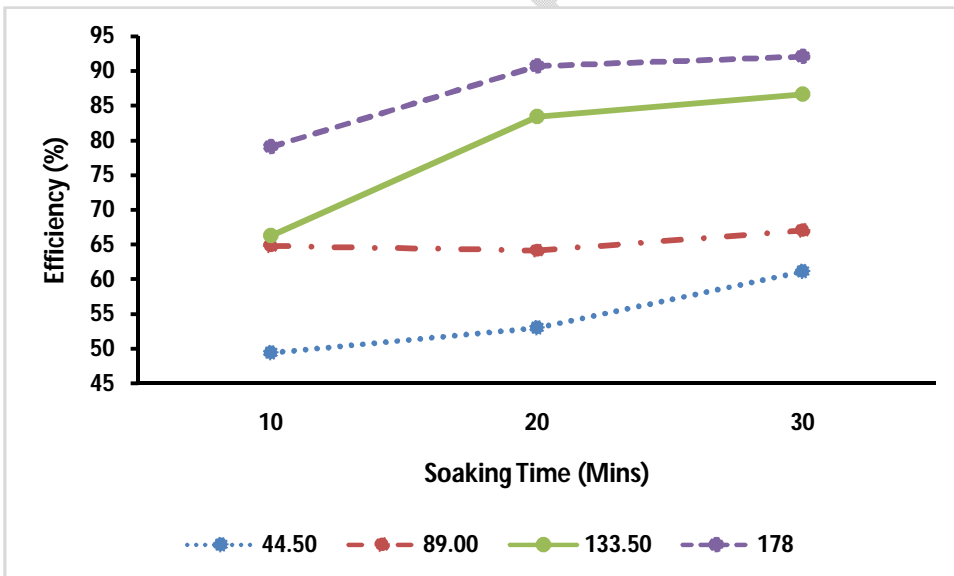

Fig 7: Effects of soaking time and decortivating length on decortivating efficiency

3.2.3 The Interaction between broken percentage and decortivating efficiency

The interaction between broken percentage and decortivating efficiency is as presented in Fig 8. The interaction effect showed that an increase in decortivating lengths leads to marginal differences of less than 1% in broken percentage and a 29% to 37% increase in efficiency. However, increasing the wetting time results in a higher percentage of broken cowpea, ranging from 2.4% to 3.1%, and increase in decortivating efficiency from 2.8% to 20.3%. The results indicate that both decortivating shaft length and wetting time influence the broken percentage and efficiency. Nonetheless, longer decortivating lengths result in more efficient decortivating, while longer soaking times increase the risk of breaking of cowpea.

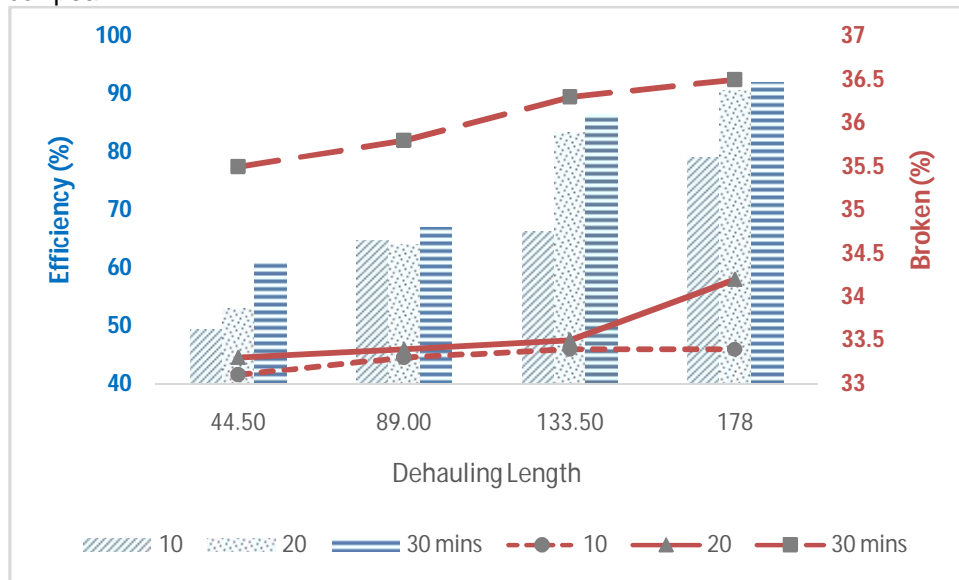

Fig 8: Interaction effect of the decortivating length and wetting time on decortivating efficiency

CONCLUSION

The cowpea decorticator evaluated in this study presents a promising alternative to traditional methods of cowpea processing. The decorticator's performance was assessed across various decortivating lengths and wetting times, with the efficiency reaching its peak at 30 minutes of wetting time and 178 mm of decortivating length. However, it is important to note that longer wetting times increase the risk of cowpea breakage, highlighting the need to optimize both decortivating efficiency and the percentage of broken cowpea for efficient and cost-effective cowpea processing, particularly for small and medium-scale cowpea processors.

REFERENCES

1. Ngoma, T. N., Chimimba, U. K., Mwangwela, A. M., Thakwalakwa, C., Maleta, K. M., Manary, M. J., & Trehan, I. (2018). *Effect of cowpea flour processing on the chemical properties and acceptability of a novel cowpea blended maize porridge*. 1–10.
2. Affrifah, N. S. (2021). *Cowpeas: Nutritional profile, processing methods and products A review*. September, 1–12. <https://doi.org/10.1002/leg3.131>
3. Henshaw, F. O., Mcwatters, K. H., Oguntunde, A. O., & Phillips, R. D. (1996). Pasting Properties of Cowpea Flour: Effects of Soaking and Decortication Method. *American Chemical Society*, 1864–1870.
4. Rangel, L., Jorge, M. D. C., Guerra, A., & Fullen, M. (2019). Soil erosion and land degradation on trail systems in mountainous areas: Two case studies from South-East Brazil. *Soil Systems*, 3(3), 1–14. <https://doi.org/10.3390/soilsystems3030056>
5. Os, K., Ef, A., Isiaka, M., & Ka, A. (2017). *Journal of Applied Performance Evaluation of the Cowpea Wet De-Hulling Machine*. 6(1), 1–6. <https://doi.org/10.4172/2168-9873.1000248>
6. Uzogara, S. G. (2016). Processing and utilization of cowpeas in developing countries: A review. *Journal of Food Processing and Preservation*, May 2007. <https://doi.org/10.1111/j.1745-4549.1992.tb00195.x>
7. Hamid, S., Muzaffar, S., Wani, I. A., Ahmad, F., & Munaf, M. (2016). Physical and cooking characteristics of two cowpea cultivars grown in temperate Indian climate. *Journal of the Saudi Society of Agricultural Sciences*, 15(2), 127–134. <https://doi.org/10.1016/j.jssas.2014.08.002>
8. Ogunnigbo, C. O., & Adetan, D. A. (2018). Assessment of a modified mixer for wet dehulling of cowpea (

- Vigna unguiculata). *AgricEngInt: CIGR Journal*, 2018, 20(2).
9. Olawale, C., Aderibigbe, D., & Femi, O. Effect of soaking time on some engineering properties of cowpea (*Vigna unguiculata*). *AgricEngInt: CIGR Journal*, July.2018
 10. Solanki, C., Mridula, D., Kudos, S. K. A., & Gupta, R. K. (2018). Optimization of dehulling parameters using indigenous oat dehulling machine. *International Journal of Chemical Studies*, 6(6), 169–175.
 11. Sreerama, Y. N., Sashikala, V. B., & Pratape, V. M. (2009). Effect of enzyme pre-dehulling treatments on dehulling and cooking properties of legumes. *Journal of Food Engineering*, 92, 389–395. <https://doi.org/10.1016/j.jfoodeng.2008.12.008>
 12. Jenike, A.W. (1994). Storage and Flow of Solids. Bulletin No.123. *Engineering Experimentation*, University of Utah.
 13. Idowu D.O. and Owolarafe, O.K. Development of a Snake Gourd Seed Decorticating Machine. *Journal of Engineering Research and Reports*.2021; 20 (12):177-192.
 14. Beveloo, W.A., Leniger, H.A., and Van de Velde., J. The Flow of Granular Solids through Orifices. *Chemical Engineering Science*. 1961;15: 260 -269.
 15. Khurmi, R.S. and Gupta, J.K. A textbook of machine Design. 15th Edition Schand and company Ltd. New Delhi, India, 2005.
 16. Singh, R. and Mangaraj S.(2013). Development and Evaluation of Centrifugal Sheller for Muskmelon Seed. *International Research Journal of Biological Sciences*, 2(3): 7- 10.
 17. Hall, A.S, Hollowenko, A.R., Laughlin, H.G. Schaums.. outline Series of theory and probles of machine design. new york;McGraw-hill. Publishers incorporated.1983
 18. Gojiya, D., and Gohil, V. Design and development of low cost sesame dehuller and its process standardization. *Journal of Food Science and Technology*, June. 2022. <https://doi.org/10.1007/s13197-022-05524-y>
 19. Amoah F. Modification and evaluation of a Groundnut Craker for Craking Jatropha Seeds. Unpublished (MSc) thesis submitted to the Department of Agricultural Engineering, Kwame Nkrumah University of Science and Technology, Ghana. 2013.