

Review Article Wearable technologies for handisports applications

ABSTRACT

In this survey, the concept of wearable technologies will be studied. It will be applied to the case of disability and mainly vision loss.

Indeed, the vision loss severely restricts a person's lifestyle and activities. The mobility of the visually impaired is important and can be difficult due to the inability to determine their positions and the location of objects in the environment. For the visually impaired, it can be difficult to observe the surrounding environment to gain knowledge and navigate to find the shortest and easiest path to their final destination. They just have the ability to walk through static routines that are important in their lives, with mobility equipment and the memories stored in their exploration long-term.

The electronic device can now merge seamlessly into ordinary clothing. Using various conductive textiles, data and power distribution as well as sensing circuitry can be incorporated directly into clothing.

In this work, we try to innovate and to participate in the creation of the "functional textile products" of tomorrow and to provide the best products to fulfil the customer's requirements, with a big level of functionalities and especially to give a comfort sensation to the consumer, to relax and to relieve the body pains and stress. This relaxing touch can be used in the physiotherapy to contribute in reducing many pains especially those of back.

This paper describes also some of the techniques used to build shirt from commercially available fabrics, yarns, fasteners, and electronic components dedicated to guide visually impaired persons. To solve the problem of navigation for visually impaired people, especially athletes, we will propose some wearable (sportswear) system that can help them know their route in the competitions of disabled sports (running).

Keywords: Disability, Wearable Smart textile, handisports.

1. INTRODUCTION

The designer-researchers have gone deeper into the field of textile and clothing design. Today we find high-tech inventions and innovations in clothing, particularly disabled sports clothing. These garments have primary functions such as safety, comfort and performance. It is important to do research and development for disabled sports equipment. Today, it is the trend to innovate in the functional side of these clothes. This is important research to satisfy the physical side and the psychological side of disabled athletes, visually impaired for example. It should also be mentioned that textile design initiatives are essential for this disability. Visually impaired athletes have many common problems and difficulties when practicing sport, but mobility and especially its autonomy remains the biggest problem. This highlights the role of the designer to meet the common need of visually impaired athletes. The latter require clothing that is both functional and aesthetic to protect them and facilitate their sporting activity, by providing these athletes with a certain physical and psychological comfort [1].

In general, this vision loss severely restricts a person's lifestyle and activities. The mobility of the visually impaired is important and can be difficult due to the inability to determine their positions and the location of objects in the environment. For the visually impaired, it can be difficult to observe the surrounding environment to gain knowledge and navigate to find the shortest and easiest path to their final destination. They just have the ability to walk through static routines that are important in their lives, with mobility equipment and the memories stored in their exploration long-term.

To solve the problem of navigation for visually impaired people, especially athletes, we will propose some wearable (sportswear) system that can help them know their route in the competitions of disabled sports (running).

Research made of textile constantly speeds up to the clarification of new products to the various properties: warming, air-conditioning, refreshing, relaxing, massaging,

While Electronic devices are empowering fashion accessories, clothes are still the heart of fashion, and as humans we prefer to wear woven cloth against our bodies. The tactile and material properties of what people wear are important to them, and people are reluctant to have wires and hard plastic cases against their bodies. Those electronic devices use passive components sewn from conductive yarns as well as conventional components, to create interactive electronic devices, such as LED giving light when we need it [2].

In this context, integrating electronics into clothing is a major new concept, which opens up a whole array of multi-functional, wearable electro-textiles for sensing/monitoring body functions, delivering communication facilities, data transfer, individual environment control, and many other applications. With revolutionary advancements occurring at an unprecedented rate in many fields of science and electronics the possibilities offered by wearable technologies are tremendous and widespread. These advancements will transform the world and will soon begin to permeate into commercial products [3].

One goal of our work is to create electronic garments and textiles that exhibit integrity, that is, garments that look, feel, wash, and wear as well as ordinary clothing. In this context, system integration becomes the art of partitioning an electric device across several items of clothing.

This electronic device in this survey will be used to create a relaxing shirt. The idea of a textile as second skin, that touches to the pleasures of the senses answering a need for more comfort and functionalities.

Slater [2] defined comfort as a "pleasant state of physiological, psychological, and physical harmony between a human being and the environment". Slater identified the importance of environment to comfort and defined the three type's names. Physiological comfort is related to the human body's ability to maintain life, psychological comfort to the mind's ability to keep itself functioning satisfactorily with external help, and physical comfort to the effect of the external environment on the body [3].

The fashion industry is facing new challenges: "intelligent textiles", "smart clothes", "i-wear" and "fashion engineering" are only a few of the keywords which will revolutionise new and old industry within the next 5 to 10 years. The integration of high-technology into textiles, e.g. modern communication or monitoring systems or the development of new materials with new functions, has just started with timidity, but the branch already propagates an enormous boom for this sector. Especially applications for the health and security sector, e.g. clothes with extern monitoring systems, are already today anticipating a great demand.

There is a major potential for European companies to improve and strengthen their position in the global market for "smart clothes".

Besides, High-tech-textiles, intelligent clothes and generally new concepts for wearable electronics, embedded technologies and disappearing computing has attained high importance in multidisciplinary cross-section development and the market. The creation of these new technologies requires resolving various questions of new developments in smart fashion products and intelligent fashion interfaces.

In this context, with the advancement of miniaturisation of electronic components, increasing efficiency of wireless communication (Bluetooth), and also the UMTS standards, a higher growth of well above average is expected and especially in wearable electronic textile.

This new tendency is due to requirement of consumer for more and more comfort and functionalities, so the modern consumers are interested in textile products that not only look good, but also feel good. They would like those textiles to coincide with their chosen attitudes, roles, and images. It has been identified, by both natural and synthetic fiber

marketers, that consumers are increasingly involving more than their visual sense and are allowing touch, smell, intuition, and emotion to influence their experience. Interest is growing in better feeling fabrics. Comfort is being reinforced as a key parameter in clothing [4]. So comfort is a fundamental and universal need for consumers. As consumers ourselves, everything we do can be considered to be an effort to improve our level of comfort in life. Clothing and textile products are essential materials that we used everyday to obtain physiological and psychological comfort and more fundamentally, to ensure physical condition around our body suitable for survival. Therefore research on comfort textile materials has fundamental meanings for the business management of textile enterprises, clothing comfort research has substantial financial implications in the effort to satisfy the needs and wants of consumers in order to obtain sustainable competitive advantages in modern consumer markets [5].

Finally consumers' requirements for textile products are for much more than comfort but also aesthetic appeal, ease of care, and durability [12].

2. MATERIAL

Human skin has a very complex structure. The skin has two layers: the epidermis and the dermis. The epidermis is the outer layer, consisting of several layers of dead cells on top of a single living cell. The dermis is the inner layer, containing most of the nerve endings in the skin [6, 7, 8]. So the human skin is the interface between the human body and its environment; it is richly innervated and contains specialized sensory receptors to detect various external stimuli. There are three major stimuli:

In corresponding to these stimuli, the skin receptors produce the sensations of touch, warmth or cold, and pain [9]

During wear, textile products contacts with the skin of most part of our body, dynamically and continuously. This contact has a number of features:

- The areas of contact are large and cross over regions with various sensitivity
- The body very often changes its physiological parameters such as skin temperature, sweating rate, and humidity at the skin surface, which generate various new thermal stimuli
- The body is often in movement causing clothing to move towards and away from the skin frequently, which often induces new mechanical stimuli. These thermal and mechanical stimuli triggers responses from various sensory receptors and formulate various perceptions such us touch, tactile, thermal, moisture and more complex synthetic sensation, which affect the comfort status of the wearer.

2.1 The sport Technologies: Sports Engineering

Sport is an activity that requires physical and/or mental effort and is governed by a number of rules and customs. Bernard Lefort affirms that sport "is a generic term covering a whole set of activities (leisure, spectacle, competition, educational) and very diverse representation". In addition, sport is a driver of technical innovation in terms of textiles or form since clothing is used in extreme contexts: movements, external conditions, friction. High-tech materials are thus developed, providing specific technical qualities. Technology makes it possible to make a range of comfortable and performance-enhancing sportswear.

The use of technology by sport exists, electronic materials have long been invited into sport. Advances in electronic engineering in particular pose real questions for sport in the coming decades. Today we are talking about clothing with properties adjusted to the competition of the day, electronic materials that are included in sports clothing in order to regulate the temperature, tension and heartbeat of athletes. On the side of human physiology, one of the current avenues of research is the monitoring of physiological parameters of athletes[11] .

2.2 The main concepts of sport

Sport like any field has main concepts, which are performance, comfort and safety.

2.2.1. The performance

The performance is directly related to the contribution of the textile garment, an athlete who feels good in his clothes is able to produce more effort and he feels less fatigue. Talking about the handling of the ergonomics of the garment which is an important factor for the wearer, it is one of the success factors in areas such as work and leisure and it will be

increasingly important for an athlete especially in the disabled. According to Fabien Roland, ergonomics is defined by: "the adequacy of a material, and not only of a garment, to the function assigned to it. Each sport will have its own needs, therefore its own clothes, with one constant: to serve the athlete and in particular not to hinder his movements. and improves aerodynamics. In this context, Fabien Roland indicated that: "In most cases, it is essential to offer the external environment the minimum of asperities, friction, and on the contrary to favor the penetration of the fluid , air or water depending on the sport, what is called aero or hydrodynamics". In addition, an elastic garment that tightens parts of the body increases blood flow to the muscles and improves their performance. The elasticity of the textile will allow an activation of its blood flow thanks to the phenomenon of compression of the athlete's body
In addition, a slight restraint of various parts of the body will increase the muscular performance of the athlete and his recovery after the effort. It is therefore a relationship between performance and textile clothing which is expressed differently and at three main levels which are the ergonomics of the garment, elasticity and compression (activation of blood flow), and the aero surface / hydrodynamic.

2.2.2. Comfort

Comfort is a rather complicated concept, in which enter certain factors such as: thermal regulation, breathing and drying, feeling of displeasure from bad odors, protection vis-à-vis the environment, and wearing comfort. or the second skin.

- the thermal regulation makes it possible to feel an almost constant temperature throughout the movement, also it makes it possible to balance between the sensations of cold and heat.
- the almost instantaneous breathing and drying prevent the sportsman from bathing in his perspiration. In addition, humidity causes a bad feeling. In this case, it excites a risk that the sportsman cools down quickly and subsequently there is a loss in his performance.
- the feeling of displeasure comes from bad odors, against which it is necessary to fight, especially in sports requiring long-lasting effort.
- the protection of the environment in which the athlete moves, i.e. it is necessary to protect oneself from the climatic conditions which can change during the sporting activity.
- the pleasure of dressing is a particular aspect of comfort. A light and soft garment can be talked about in the technical aspects as well as in the fashion aspects. This is "comfort to wear".

For a visually impaired person, comfort comes when they can move easily during these movements. After the canes, the guide dog and all the classic means of assistance, clothing equipment is beginning to appear allowing to combine all the requirements, all the needs. We take the need for navigation which can be served by functional clothing using electronic components [28] .

2.2.3 Security

Security needs arise from the aspiration to be physically and morally protected. Moreover, they evolve with the times and the systemic environment of society. They are mainly related to several themes, we are interested in all three: physical security; moral and psychological safety as well as health.

Clothing can be a means of protecting the wearer against uses that require a high-performance level of safety, such as protection against flames (firefighters), chemical risks, concrete obstacles (visually impaired people). For athletes, it is also obviously necessary that it be protected. Sports suits are functional garments and accessories made to guarantee individual safety.

Safety aspects are essential in many sports, and not only the risks incurred in fencing, shocks and falls in cycling, skiing, hockey, etc., but also particular risks such as deviation for the visually impaired during athletics at disabled sports competitions. Innovations in protection lead the textile designer to design new specific products, particularly for the visually impaired to solve the problem of navigation [10] .

In this context, according to Jürgen Weineck, "Sports performance capacity represents the degree of possible improvement of a certain motor activity and, being part of a complex framework, it is conditioned by a plurality of specific factors".

3. TECHNOLOGY

3.1 Technology at the service of sport

The constant search for performance leads the sportsman to the use of new composite materials for sports equipment. at the service of the disabled sports field. In this context, "Sports performance is really that of the 'Human/Material pair'. The world of sport is always at the forefront of the use of novelties that will make it grab a few tens or hundredths of a second in order to establish the new record. The development of materials capable of promoting sliding, of resisting shocks and vibrations, of fibers with high mechanical and thermal performance have enabled the sportsman to be more efficient in action thanks to better comfort and increased protection [30] . .

3.1.1 Technology at the service of sports equipment.

In terms of sports equipment, in order to design them, designers and engineers must study the physical phenomena that occur during its operation. We take the example of shoe design with an electronic chip. This example allows the sportsman to know the characteristics of his race (calculation of the speed, the number of kilometers covered).

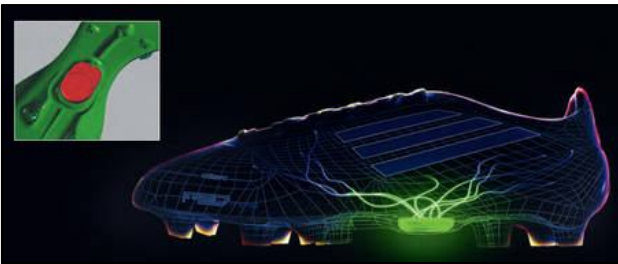

Fig. 1. the shoe of a microchip [11]

Another example that confirms the intervention of technology and electronic innovation in the field of sports, the 'StretchSense' is an attractive technology in the wearable equipment sector. This product also offers an interesting range of integration options. These are electronic sensors that naturally measure the movements of athletes on the field. They are light, robust and connected to a Bluetooth circuit. As an athlete moves, the sensor stretches and an Android app displays real-time motion feedback.



Fig. 2. StretchSense from StretchSense Ltd., New Zealand [12]

Another example of electronic technology in the field of sport is the use in particular of timing in athletics during the 2012 Olympic Games, 'Scan'O'Vision'. This new photo-finish camera is an "online scanner" that displays an image as an LED strip with a varying frame rate depending on the camera.



Fig. 3. installation of timing equipment [13]

3.1.2 Technology at the service of sportswear

The improvement of textile equipment through the intervention of advanced technologies allows athletes to achieve comfort and safety in their activities and to increase their performance. From a comfort point of view, the improvement of performance may be possible thanks to the elasticity of the textile which can cause a phenomenon of compression of the athlete facilitating the activation of his blood flow. This is why in the field of sport, it is the use of elastane which exerts compression on the body to have an activation of blood flow, which has the effect of increasing muscle performance. Another type of fabric used, cotton, which is a comfortable material and which the athlete is not bothered by the feeling of humidity that perspiration can cause.

The new generation technical materials are able to fight against bad odors due to excessive perspiration, to regulate the body temperature, even to evacuate the heat produced by the body during the intensive practice of a sport and moreover, for visually impaired athletes, we are looking for a way to have clothing that guides them during practiced disabled sports.

3.1.3 Technology at the service of disabled sports.

Competitive disabled sport is a driver of innovation. It has known several developments such as the evolution of specific materials such as the wheelchair and the prosthesis. According to the magazine Santé et Bien-être, "Faced with this development, the concept of specific equipment adapted to sport quickly imposed itself. Initially, individual and empirical initiatives attempted to find solutions. They had the merit of moving things forward and provoking more scientific reflections, designs, experiments and achievements".

Indeed, during the Paralympic Games in London in 2012, futuristic equipment allowed athletes to achieve interesting performances. Researched tools have been jointly designed by researchers and athletes. In this context, Santé et bien-être affirms that "The remarkable performances of athletes are linked to the appearance of futuristic equipment but above all to the courage and the will to surpass themselves and to achieve exploits of these extraordinary athletes. As Philippe Croizon says, "nothing is impossible" and also "the Paralympic champions deserve to be recognized as the gods of the Olympic stadium".

Technology and innovation have a complementary relationship, but there is a type of innovation that can be present without or with the intervention of technology [14.]

3.2 Types of innovation

There are two types of innovation which are incremental innovation and disruptive innovation.

3.2.1 Incremental innovation

Incremental innovation is a change aimed at improving the characteristics of an existing product or a range of products. These improvements are often detected by the marketing function and correspond to needs expressed by the user. For example canned soft drinks versus bottled. These innovations literally make the product live or survive. The Business Dictionary has defined incremental innovation as: "regularly used in the high-tech business by companies that need to keep improving their products to include new features that are increasingly desired by consumers". context, we are going to present an example of the incremental innovation that is Enflux, these are smart clothes for athletes, their operation is

connected with a smartphone application and which allows them to reproduce the right movements during their training sessions.



Fig. 4. Enflux, sports clothing [15]

Enflux follows the movement of the body during exercise and captures data thanks to its 10 integrated movement sensors then transmitted to the smartphone application. "This smart garment is interesting since the quality of movement is essential for improving sports performance".

3.2.2 Disruptive innovation

Disruptive innovation consists in offering the user the same result, the same service, the same functional value, but through a different technology or process and far from current technology. For example the ballpoint pen and the fountain pen.

Not only electronic innovation is on the rise but also biological innovation, these two innovations help us to offer clothing to sports enthusiasts. Biology is constantly innovating to improve the safety and comfort of athletes. In this context, we cite the example of researchers from the MIT group who used a bacterium to design sports clothing considered to be a "second skin". MIT researchers design a tray that responds to human interaction (see Figure N15). They create a synthetic material from a programmable bacterium. When the material is activated by specific thresholds of heat and humidity, it physically transforms, opening flaps that allow sweat to evaporate.



Fig. 5. The bacterial jacket, seen from behind, the touch interface plate. Flaps open during climate change [16]

The group investigated how different bacteria change when exposed to moisture and how to take advantage of these properties. The secret of this garment is the *Bacillus Subtilis Natto* bacterium, it is a bacterium found in the soil in Japan.

Additionally, this product includes fluorescent bacteria that can light up when the athlete exercises in the dark and odor-producing bacteria that can make them feel better after training.

To conclude, this part shows the strong presence of innovation in the field of functional textiles. We can introduce technology-centric innovation in functional textiles as a key concept for designers, researchers, and engineers. It is a reciprocal relationship between the field of design and advanced technologies.

4. METHODS

The electronic materials used in this experimental part are the "Localino 2.0" navigation system, the "ERM" and "LRA" vibrators, cables, the "power bank", a "smart phone" and also the cartography of the place through a computer. We will use the 'Localino' to locate visually impaired people during the race. In addition, we will use the ERM and LRM vibrators for obstacle detection, as well as the cables to connect them (the 'Localino' 2.0 and the Vibrators) [16] . The 'Localino' is composed of a 'Tag' and 'Anchors'. The 'Tag' is intended to send signals to the 'Anchors'. Also using the 'power bank' to keep more energy for the system, a smart phone for the application and the stadium mapping to know the precise position visually impaired people.

The 'Localino' 2.0 is based on a 'Decawave UWB transceiver', an 'MCU' of the STM32F1 series and 'anchors', offers a backup 'WIFI' link. In this way, it can be integrated into any existing wireless network and transfer telemetry data to a server in near real time.

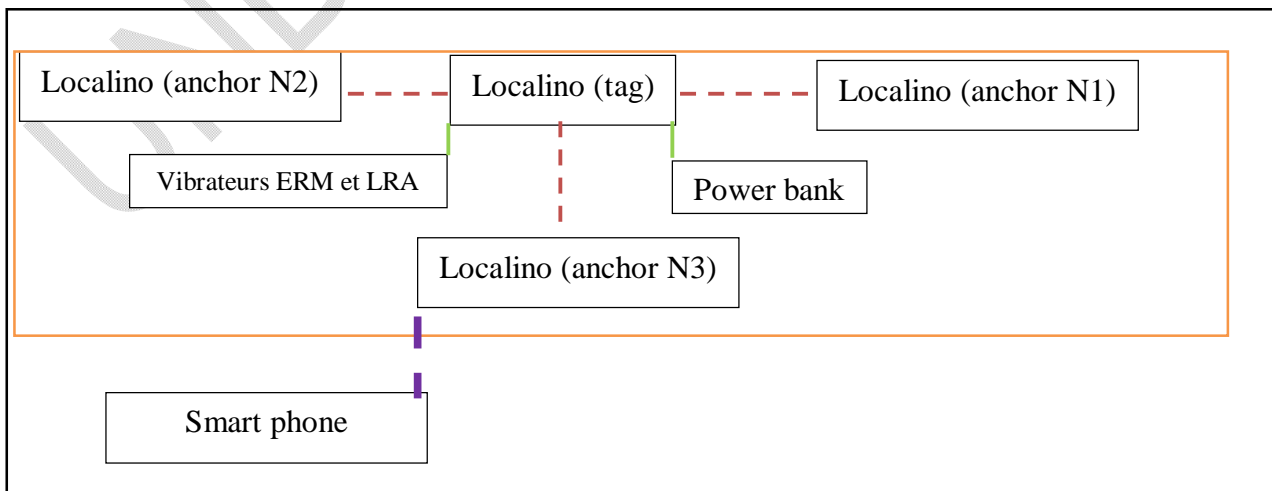

Legend

Cables



-  Cables
-  Connection via 'Localino' application
-  Connection via « localino » network

Fig. 6. Connected components

The indoor accuracy of the 'Localino' is less than 10 cm. It is a very competitive indoor location system. We use the 'Localino', placing the 'Tag' worn by the visually impaired person in different positions. Next, we will measure the distance between the 'Tag' and the 'Anchors', placing the 'Anchors' which are three in different positions. At the beginning we put the 'Tag' in the center of the experiment space, and the 'Anchors' marks the distance measurement (D1). After, the visually impaired when he changes his position, the 'Localino' marks the distance (D2), then we compare (D1) and (D2) [38] .

5. EXPERIMENTATION: INDOOR EXPERIMENTATION (WITHOUT VIBRATOR)

In order to experience the operation of the 'Localino', it is important that the first experimentation be in an indoor environment. At first, we downloaded the 'Localino' app, proceeding with the following steps:

- Connect the router and the anchors.
- Select the WI-FI icon on the computer, open the network and change the settings. (Compatible with 'Localino')
- Choose the wireless network and click on the Internet protocol version 4, after choosing the properties and use the following IP address, "file 'Localino', TCP-IP settings".
- Open the 'Localino' file and choose the 'Localino' processor.
- Open the 'Localino' application and access the configuration parameters.
- Ensure that once the 'Localino' is connected to the 'anchors' and WI-FI.
- Fix three 'anchors' in different places and make a large distance between them. The 'anchors' are fixed in different places in the rooms and the person to be monitored must wear the 'tag'.
- Put the 'tag' in the person's clothing; now he is ready to change position and the 'Localino' device is able to measure the distance between the 'anchors' and the person.



Fig. 7. The main component of the experiment: 'Localino'

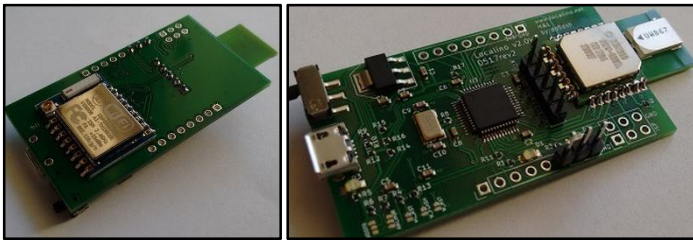

Fig. 8. And 9. 'Localino' front and rear view



Fig. 10. the experiment T-shirt. The 'Localino' and the power Bank inserted in the clothing of the experiment (A basic cotton t-shirt)

The results of the experiment were encouraging. The 'Localino' detected the positioning of the visually impaired person. The latter will be able to cross his path in his house, but the detection was not in a fast way. This problem is definitely related to the quality of 'Localino'. Regarding the first results of the first experiment, we found that during a period of time, the 'Localino' marks the change of the distance between the receiver and the transmitter in a slow way.

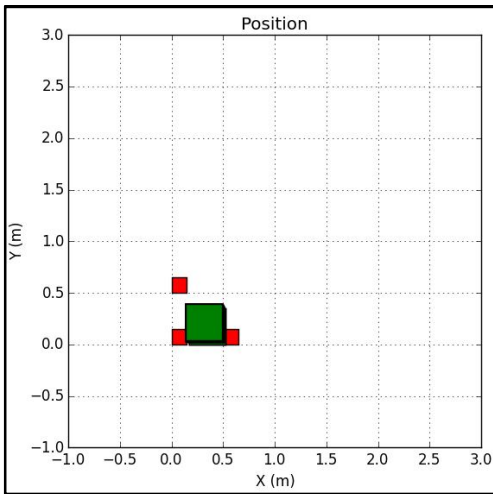

Fig. 11. Position of 'Localino' after connecting 'tag' and 'anchors'

5.2 Proposals for sportswear

We have offered the following sportswear sketches in a mood board, and we have indicated the electronic components used in our experimentation.

These two models represent two combinations. The first is intended for female athletes and the second is intended for male athletes. Each of them is composed of a top and a bottom. The top is in the form of a tank top, round neck and with a belt at the waist that the athlete can fix the 'Tag' of the 'Localino' using velcro. The bottom is in the form of mid-leg shorts which are designed with a pocket on the right where the athlete puts the "power Bank" and a waistband equipped with elastic at the pelvis to adapt to the morphology of the athlete's user. There are some decorative details in the top at the sleeves and at the hem of the shorts.

In the different phases of the experimentation, we encountered problems related to the connectivity of the components and the delay in the responses of the main component, the 'Localino', also problems related to the comfort and the way to camouflage the components in the clothes.

Indeed, we seek to find improvements for this experimentation such as the miniaturization of components from the search for other connection components which transmit results more quickly (more reactive) and which give more performance and which are less complicated for the different phases (installation, connection, operation).

Finally, our idea of guiding and helping visually impaired athletes from a navigation system is a particular case that we can generalize for other visually impaired people and which can be an idea conveyed for other users to guide them in their navigations.

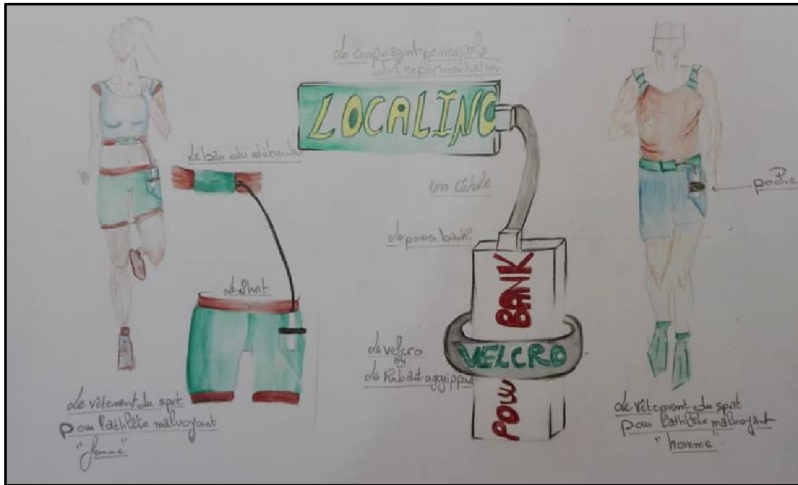

Fig. 12. Products mood board proposition

7. CONCLUSION

The complementarity of researchers in the field of textile design and electronic engineering has marked this scientific research. This interdisciplinarity in design research can give us hope to improve the quality of life of many of us who suffer from different problems on a daily basis.

Despite the miniaturisation of electronics, common technologies still limit the comfortable integration of electronic device into simple, everyday fashion objects.

In this survey, we have shown some methods to combine conventional sewing and electronics techniques with a novel class of materials to create more functional textile dedicated to the textile product using wearable technologies for visually impaired person.

Others functional textiles can help the textile designer to create new applications to facilitate our daily by improving comfort sensation and especially relaxation as solutions for future applications in the textile domains for answering consumer comfort requirement and well being for disable persons.

As perspectives of this work, we can cite:

- Improve the aesthetic aspect of the garment so that it is more of a design product.
- Experiment with other electronic components such as the 'Nanotron' device instead of the 'Localino'.
- Improve the performance of electronic components.
- Focus on the concept of component minimization.
- Generalize the idea of navigation: idea conveyed to other users

REFERENCES

1. L. Fourt and N.R.S. Hollies. *Clothing: comfort and function*, Marcel Dekker Inc., New York, NY, USA, 1970
2. K. Slater. *Human comfort*, Thomas Springfield, USA, 1985
3. K.L. Hatch. *Textile Science*, West Publishing Company, New York, NY, USA, 1993
4. Ann. Fibers of the ninties. *Textile view Magazine*, 1991, 1-11
5. Y. Li , “The science of clothing comfort”, *Textile progress* Volume 31, Number ½ , 2001, ISSN 0040-5167,
6. G.J. Pontrelli. “Partial Analysis of Comfort’s Gestalt”, in *clothing comfort* (eds N.R.S. Hollies and R.F. Goldman), Ann Arbor Science Publishers Inc., Michigan, USA, 1977, 71-80
7. M.A. Heller and W. Schiff. *The psychology of touch*, Lawrence Erlbaum Associates, Hove and London, UK, 1991, 354.
8. S. Coren and L.M. Waed. *Sensation and perception*. Harcourt Brace Jovanovich, New York, NY, USA, 1989
9. A. Iggo. *Sensory receptors, cutaneous, in sensory system II, Senses other than vision* (ed J.M. Wolfe), A Pro Scientia Viva Title, Boston, USA, 1988, 109-110
10. W.J. Kirk and S.M. Ibrahim, “Fundamental relationship of fabric extensibility to Antropometric requirement and garment performance”, in *Textile Research Journal*, 1966, 57, 37-47
11. M.J. Denton. Fit, “Stitch and comfort”. Presented at 3rd Shirley Int. Seminar: *textiles for comfort*, Manchester, UK, 1970
12. R. Vatsala and V. Subramaniam. “The Integral Evaluation of fabric performance”, in *Journal of Textile Institute*, 1993, 84, 495-500
13. Y. Li “Wool Sensory Properties and Products Development”, in *Textile Asia*, 1998, Vol. XXIX, 5, 35-39.
14. THE linen AND HEALTH
15. E. Rehmi Post, Maggie Orth, “Smart Fabric, or Washable Computing”, of the First *IEEE International Symposium on Wearable Computers*, October 13-14, 1997, pp. 167-168, held in Cambridge, Massachusetts.
16. X M Tao, *Wearable electronics and photonics*, Edited by, Hong Kong Polytechnic University, Hong Kong, ISBN 1 85573 605 , 5, March 2005.