

## Diversity analysis of *Rhizoctoniasolani*Kuhn isolates causing sheath blight of rice in Eastern Uttar Pradesh, India

### Abstract

The sheath blight of rice is a devastating fungal disease, which is caused by *Rhizoctoniasolani* AG1 IA. Twenty-one sheath blight isolates of rice were collected from different locations in eastern Uttar Pradesh, India, to study the variation in cultural, pathogenic, and molecular characterization. All the *R. solani* isolates were classified into four groups depending on the arrangement of sclerotia, i.e., peripheral, centre, scattered, periphery and centre 11, 1, 5, and 4 isolates, respectively. Depending on pathogenicity isolates are grouped into weakly virulent, virulent and highly virulent representing 12, 4, and 5 isolates, respectively. The random amplified polymorphic DNA has been successfully used for molecular characterization. In our study, ITS1/ITS4 and AG-1 IA-specific markers yielded reproducible banding patterns. UPGMA cluster analysis revealed two major clusters, A and B, with a 13.85% dissimilarity value. This study does not correlate with virulence, geographical location, and RAPD profile groupings.

**Keywords:** *Rhizoctoniasolani*AG1 IA, cultural, pathogenicity, molecular characterization, Rice

### Introduction

Rice (*Oryzasativa*L.) is a major source of carbohydrates, protein, and other essential nutrients for billions of people worldwide, especially in developing countries (Parengamet al., 2010). Moreover, it is cultivated in more than a hundred countries, with a total cultivated area of nearly 1.5 billion hectares, producing about 481.54 million tons annually, but the consumption of rice is at an extreme level by the world population of tremendously developing low-income countries ([www.statista.com](http://www.statista.com); GRiSP, 2013). To meet the increasing population's demands and maintain self-sufficiency, the present production levels need to be increased by over 40% by 2030 and 70% by 2050 (FAO, 2018). However, China and India are the largest rice-producing countries in the world; jointly they account for 51.4% of the global rice production (Yellareddygarriet al., 2014; Naveenkumar et al., 2017). In India, nearly 112.9 million tonnes of rice are grown in 43.5 million hectares with a productivity of 2578 kg/ha. ([www.indiastat.com](http://www.indiastat.com)).

The production and productivity of rice are affected by many abiotic and biotic factors, which cause yield losses of up to 45% (Margani and widadi-Widadi2018). Among all the biotic stresses, the fungal diseases in rice are the most predominant worldwide

**Comment [u1]:** Here are five groups. "Centre" repeats itself. Probably 'Central and peripheral'. Needs to be corrected.

**Comment [u2]:** Need to edit the citation or references  
Margani R., Hadiwiyono H., Widadi S. 2018. Utilizing *Bacillus* to inhibit the growth and infection by sheath blight pathogen.

(Naveenkumaret al.,2021). The productivity of rice is affected by several fungal pathogens (Margani and widadi2018), of which *Rhizoctoniasolani* Kuhn causes sheath blight (ShB) disease of rice is one of the most destructive pathogens causing disease in rice and considered as world's significant disease, second most prevalent to the blast disease (Neha et al., 2016; Mollaet al., 2020). It became more prevalent in most of the improved varieties grown in India (Prakasamet al., 2013).

Formatted: Font color: Red

*Rhizoctoniasolani* is a universal ubiquitous and ecologically diverse soil-borne and facultative plant pathogen, which causes diseases such as sheath blight, banded leaf blight and brown patch in many plants with more than 27 families of dicots and monocots.

(Margani and widadi2018).*R. solani*isolates are genetically diverse in their cultural characteristics and the range of host plants they infect. *R. solani* is a species complex that is classified into 14 anastomosis groups (AGs) (AG 1 to AG 13 and AG B1) based on their host specificity and their hyphal fusion reaction (Tuncer and Eken., 2013; Misawa et al., 2019). *R. solani* AG-1 has been further classified into six intraspecific groups (ISGs), i.e., IA, IB, IC, 1D, IE, and IF, depending on their characteristic features like bio-chemical, cultural, genetic, and pathogenicity (Yang and Li 2012; Ghosh et al., 2014). In India, *R. solani* isolates infecting rice belonged to the AG-1 IA group, while in Japan and Taiwan belonged to AG-1 IA and AG-2-2 (Gonzalez-Vera et al., 2010).

Formatted: Font color: Red

Symptoms of this disease generally appear at the maximum tilleringstage as a lesion on leaf sheath and affect all plant parts above the waterline,viz., sheath, internodes, upper leaves, and panicles (Uppala and Zhou, 2018). In general, the disease may be diagnosed by the appearance of one or more relatively large, oblong, or irregularly elongated, greenish grey, water-soaked lesions on the leaf sheaths. As the lesion develops,the centre becomes bleached with an irregular purple-brown margin (Yellareddygarriet al., 2014; Singh et al., 2016). Finally, the disease results in the blighting of leaf sheaths andis commonly known as sheath blight. The sclerotia of the pathogen remain in soil and water viable for up to 3 years (Kumar et al.,2009), indicating that soil-borne sclerotia are asignificantsource of disease inoculum.Sclerotia are formed on the basal leaf sheaths, whichseem white when young and become brown or dark brown later (Uppala and Zhou, 2018). Various estimates of crop losses due to sheath blight fungus on rice ranging from negligible to 50% have been reported under favourable environmental conditions (Richaet al., 2016; Neha et al., 2016).

Formatted: Font: Not Italic

However, understanding the concept of plant-pathogen interactions and disease epidemiology is highly dependent on knowledge of the pathogen diversity at the field level. Thus, there is a need to characterise isolates/pathotypes through morphological, cultural,

virulence analysis and genetics of pathogen with molecular markers and phylogenetic relationship. Lore et al. (2015) and Goswami et al. (2017) reported morphological and virulence patterns of various isolates of *R. solani*.

Perhaps, the evaluation of genetic variation in the pathogen isolates has become the first step in understanding the population structure (Banerjee et al., 2012). The molecular techniques become reliable and highly suitable tools for identifying pathogen species and assessing genetic variation within collections and populations (Sundravada et al., 2011).

The host range/ specificity of pathotypes and the fluctuations in pathogen character within the local population is a crucial factor influencing the management strategies of ShB. Nowadays, integrated plant disease management is gaining popularity for controlling plant diseases to reduce fungicide usage and achieve eco-friendly, inexpensive, and effective management methods by combined application of all available management strategies such as cultural, biological, and chemical along with resistant varieties (Singh et al., 2016; Chakrabarti et al., 2018).

## **Materials and methods**

### **Collection of sheath blight disease samples**

During *Kharif* 2019, a targeted sample survey was conducted in various parts of Eastern Uttar Pradesh, India viz., in Varanasi, Mirzapur, Prayagraj, Chandauli, and Jaunpur districts that were selected to collect infected sheath blight rice samples for diversity studies in *R. solani* (Table 1). A stratified random sampling method (transect sampling by walking around the field) was used for sampling at the boot stage from 7 to 10 transects, at least 10m apart, in each area (Linde et al., 2005).

### **Isolation and purification of *Rhizoctonia solani***

Symptoms on rice sheaths, leaf portions, and signs (sclerotia) on the disease isolate at each observation during the survey are recorded. Besides, information like plant characters and geographical information (longitude/latitude) were collected. Infected plant tissues are cut into pieces (~0.5 cm), surface sterilised with 1% sodium hypochlorite solution for 30 seconds, rinsed three times with sterile distilled water and blotted dry, and transferred to an isolation medium, i.e., (2%) water agar. The plates are then incubated at 26±2 °C. After 2-3 days, cultures were examined microscopically for morphological characters typical of *R. solani*. Hyphal tips of each isolate growing from the infected plant tissue are sub-cultured on fresh PDA plates and incubated at 26 ± 2° C for further purification. Following pure cultures of the pathogen, isolates were kept at 4°C for short-term storage.

### **Cultural variability among *R. solani* isolates**

Isolates of *R. solani* were grown on fresh PDA medium plates in three replications and incubated at  $26\pm 2^{\circ}\text{C}$  for studying colony characters such in terms of mycelial growth rate, mycelial dispersion, and growth rate, the pattern of sclerotia, time of occurrence, the texture of sclerotia, colony colour, and sclerotial colour as described by Susheela and Reddy (2013), Mishra et al., (2014).

#### **Colony diameter and growth rate**

The diameter of the colony was recorded at regular intervals of 24, 48, and 72 hours at  $26\pm 2^{\circ}\text{C}$ . Isolates were classified into three groups such as fast, medium, and slow. Growth was measured for each isolate with three replications.

#### **Type of mycelium dispersion of *R. solani* isolates**

The mycelial dispersion of *R. solani* isolates was determined at 7 DAI and was classified into three groups based on different growth patterns viz., fluffy, appressed, and raised.

#### **Colony colour**

The colour of the colony was determined by using Adobe Photoshop CS3 (Version 10) in the form of RGB (Red, Green, and Blue) values. The colour of mycelium was examined 4 days after incubation (DAI). Based on mycelial pigmentation, the cultures were assigned to different groups. The grey coefficient/value was calculated by using the following formula:

$$\begin{aligned}\text{Grey coefficient/value} &= 0.2989*R+0.5870*G+0.1140*B \\ \text{Range of RGB values} &= 0-250 \text{ (Pure white}=250: \text{ Pure black}=0)\end{aligned}$$

Where R=Red; B=Blue; G=Green

#### **Sclerotial variability of *R. solani* isolates**

Time taken for sclerotial formation, colour, number, sclerotial pattern, size, sclerotia location, and texture of sclerotia of each isolate were recorded at 10 DAI at  $26\pm 2^{\circ}\text{C}$  sterilized plates containing PDA medium.

#### **Time taken for sclerotia formation**

The time required for initiation of sclerotia of *R. solani* isolates was recorded by regular observation of culture plates for every 12h interval. Depending on the sclerotia initiation, the isolates were categorised into three groups fast, moderate, and slow (Kuiry et al., 2014).

#### **Location and distribution pattern sclerotia**

The location of sclerotia of each isolate was recorded as sclerotia produced on the PDA surface after 10 DAI and recorded as surface sclerotia and aerial and surface sclerotia.

The Sclerotial position of each isolate was further divided into four different categories depending on their distribution on the culture plate, viz., periphery, centre, scattered and periphery and centre located.

#### **Number of sclerotia**

The sclerotia count was recorded by counting the number of sclerotia per culture plate. The number of sclerotia was estimated at 10 DAI and classified into three groups: more, moderate, and less.

#### **Texture of sclerotia**

The sclerotial texture of each isolate was recorded as smooth texture and rough texture after 15 DAI.

#### **Sclerotial colour**

The colour of sclerotia was determined with Adobe Photoshop CS3 (version 10) software for 15 DAI sclerotia on PDA and grouped them into four categories: brown, light brown, dark brown, and grey.

#### **Clump formation in sclerotia**

Based on the formation of sclerotia, the mature cluster by sclerotia is recorded after 15 DAI and divided into fewer, moderate, and more clumps.

#### **Honeydew secretions**

The honeydew allocation for each isolate was determined based on the formed sclerotia. Honeydew secretion of each isolate is examined and marked (+) with honeydew and (-) without honeydew.

#### **The aggressiveness of *R. solani* isolates**

The pathogenicity of all *R. solani* isolates was established by artificial inoculation in the leaf sheath of the Pusa Basmati-1 (PB-1) rice cultivar at the booting stage. The control rice plants were regularly monitored for plant growth and development of disease symptoms. Two seedlings per hill and three hills per pot were maintained. Three replications were maintained for each treatment.

#### **Inoculation of *Rhizoctonia solani* AG-1 IA**

In the greenhouse, inoculation was made by inserting a single sclerotium from the 5-day-old immature culture of *R. solani* between the leaf sheath and the culm near the ligule in the boot stage of rice. The inoculation spot was covered by wet absorbent cotton, and sterile water was added. The symptoms appeared about 48 hours after inoculation and exactly resembled those observed in field conditions.

#### **Lesion length**

The lesion length was recorded 28 days after inoculation (DAI) of various *R. solani* AG-1 IA isolates in the Pusa Basmathi-1 rice cultivar.

### **Plant Height**

Plant height was measured using a meter scale recorded at 28 days of inoculation (DAI) from ground level to the highest panicle tip.

### **Relative lesion height (RLH)**

The Relative lesion height (RLH) was calculated per tiller, the formula given by Sharma *et al.* (1990)

Relative lesion height = lesion length/plant height X 100

### **Percentage Disease Index**

The Percentage Disease Index (PDI) is calculated by ranking the RLH on a scale from 0 to 9, which gives an estimate of the disease severity for each plant.

$$\text{PDI} = \frac{(\text{sum of all ratings} \times 100)}{(\text{Total no. of observations} \times \text{Maximum scale value})}$$

### **Virulence**

Virulence of twenty-one isolates of *R. solani* was classified into 3 groups *i.e.*, Highly virulent (HV), Virulent (V), and Weakly virulent (WV). PDI% (<41.5%)=WV; PDI% (41.5 - 71.89%)=V; PDI% (>71.89%)=HV.

### **Molecular characterisation of *R. solani* isolates**

#### **Preparation of mycelial mat of a fungal isolate of *R. solani* in liquid cultures**

Fresh *R. solani* cultures were obtained from PDA plates, and a 5mm plug of mycelium was inoculated aseptically into potato dextrose broth (PDB) flasks. After inoculation, these culture flasks were maintained on an incubator cum shaker at 28°C for seven days at 150 rpm. After ten days of incubation, the fungal mycelial mat was harvested by funnel filtration and blotted dry with (Whatman No. 3) paper.

#### **Isolation of DNA**

After chilling in liquid nitrogen, the mycelial mat was macerated in mortar and pestle. Total genomic DNA of individual *R. solani* was extracted using the Cetyltrimethyl ammonium bromide (CTAB; Sigma Chemical Co. St. Louis, MO, USA) method (Murray and Thompson, 1980). Approximately 30-40 mg of powdered mycelium was suspended in 800µl of extraction buffer (2% CTAB; 100 mM Tris, pH 8.0; 20 mM EDTA; 1.4M NaCl), incubated at 65°C, purification with phenol: chloroform: isoamyl alcohol (25: 24: 1) and cellular proteins were precipitated with 50µl of potassium acetate (3 M potassium and 5 M acetate, pH 4.8), and then, DNA was precipitated using chilled isopropanol. The DNA was dissolved in 50 µl

of sterile distilled water, and its purity was checked by running the samples on 0.8 per cent agarose gel. Nanodrop quantified dissolved DNA. 1.6µl DNA solution (50 ng) was used as a template for polymerase chain reaction (PCR). Random Amplification of Polymorphic DNA (RAPD) primers were used in the present investigation to fingerprint *R. solani* isolates (Lee et al., 1988; Wu et al., 2001).

The internal transcribed spacer (ITS) and species-specific (AG-1 IA) regions of fungal DNA were amplified using the RAPD primer pairs ITS1 (5'-TCC GTA GGT GAA CCT GCG G-3'), ITS4 (5'-TCC TCC GCT TAT TGA TAT GC-3') (White et al., 1990) and AG-1 IA forward (5'-CTCAAACAGGATGCTC-3'), and reverse primers (5'-CAGCAATAGTTGGTGGA-3'), respectively (Matsumoto, 2002).

#### **PCR amplification of DNA using RAPD primers**

The composition of the reaction mixture for PCR was prepared using the following reagents for each DNA sample.

Milli-Q-Water	: 17 µl
10 x Taq Buffer A	: 2.5 µl
2.5 mM dNTPs	: 1.5 µl
Primer	: 1.0 µl
MgCl <sub>2</sub> (80mM)	: 1.0 µl
Taq polymerase	: 0.5 µl

The master mix is prepared by mixing all the components except template DNA in a separate Eppendorf tube. Then, 23.4 µl of the master mix was added to another tube containing 1.6 µl of template DNA, and a spin was given. The PCR tubes were capped and kept in a PCR machine by the following program.

Reaction program: Initial denaturation: 5 minutes at 94 °C, Denaturation at 94 °C for 1 min, annealing at 36 °C for 1 minute, Extension at 72 °C for 2 minutes, repeat for 38 cycles, Final extension at 72°C for 10 minutes, Storage at 4 °C forever. After electrophoresis in agarose(1%) gel solution, the PCR products were stained with ethidium bromide and a 100bp DNA ladder and then analysed by a UV trans-illuminator imaging system.

For the dendrogram construction, RAPD bands successfully amplified were recorded as a presence "1" or otherwise absence "0". Probability estimates are generated from the binary data using the UPGMA cluster DARWIN version 6.0 program.

#### **Results and discussions**

The present investigation revealed the variation in cultural, pathological, and molecular variation among the isolates of *R. solani* collected from five different geographical

locations in eastern Uttar Pradesh. The isolates of *R. solani* were assigned based on the cultural features like colony colour, diameter, mycelial dispersion, time taken for sclerotia initiation, distribution pattern and location of sclerotia, texture, sclerotia colour, sclerotia number per plate. The criteria used for sub-specific grouping are cultural attributes, pathogenicity, and molecular parameters (RAPD).

#### **Cultural variability among isolates of *Rhizoctonia solani***

Cultural diversity was studied in the *R. solani* isolates and was examined at different intervals after inoculation on PDA, and the results are shown in **Table 1; Table 2; Table 3**. *R. solani* isolates were classified into four groups according to cultural characteristics, *i.e.*, Group-1, Group-2, Group-3, and Group-4, containing 11, 1, 5, and 4 isolates, respectively. Isolates showed peripheral (G-1), centre (G-2), scattered (G-3), periphery, and centre (G-4) sclerotial distribution.

**Comment [u3]:** 'Central and peripheral' in the Table 3. To be corrected.

In this study, it was shown that out of 21 isolates, 11 (52%) isolates were fluffy, 9 (42%) were appressed mycelium, and only one isolate showed raised colony texture (**Table 2**). The same type of observations was reported by Guravet al. (2017), who paid attention to three kinds of mycelial texture, *i.e.*, appressed, raised, and fluffy. Out of 18 isolates, 6 were observed as raised mycelium, 9 isolates had fluffy colonies, and 3 isolates had appressed growth on PDA media.

Among the 21 isolates, the fastest growth was recorded in 5 isolates with (>57.4 mm/day) colony diameter, while the least growth was recorded in RS-2 (26.25 mm/day) and RS-13 (27.25 mm/day) isolates on PDA media (**Table 2**). A similar type of results was made by Guvravet al. (2017) and Reddy et al. (2019). Lal et al. (2014) recorded abundant colony growth (90 mm) in eight isolates among twenty-five isolates. Whereas 4 isolates exhibited moderate increase (75-85 mm), and 13 isolates showed the slowest growth (60 mm) in 48h. Goswami et al. (2019) examined that a total of 45 isolates were grouped in fast (>26.0 mm/day) growth, 35 were moderate (25-26 mm/day) growth, while 32 were slow (<25 mm/day) growing isolates.

RGB (red, green and blue) based image analysis algorithms are the main factors for advancing image-based research for genuine and authentic phenotypic properties (Li et al., 2014). All isolates varied significantly concerning spectral RGB coefficient value in the range of (119-176.4) calculated using Adobe Photoshop CS3 version 10. These groups were (I) brown (RGB coefficient  $\leq$  148) and (II) light brown (RGB coefficient >148) (**Table 1**). Among all isolates, 12 (57%) isolates belonged to group I with lesser RGB values, and 9

(42.8%) isolates were categorised into group II with more spectral values. A similar type of results was shown by Susheela and Reddy (2013) and Goswami et al. (2019).

The *R. solani* isolates were grouped into 4 groups based on the distribution pattern of sclerotia viz., sclerotia at the periphery (11), center as a ring (1), both centered and periphery ring (4), and scattered pattern (5) (**Table 3**). The similar results agree with Sandoval et al., (2019), who categorized the formation of the sclerotic body as central, peripheral, scattered, and ring pattern. Among thirty-eight isolates, twenty-eight isolates had scattered distribution, five had centered sclerotia, three isolates had a peripheral pattern, and two isolates had a ring pattern. Goswami et al. (2019) also reported the sclerotial arrangement in a similar manner, i.e., central (35), periphery (28), scattered (44), centered, and periphery (3).

The colour of sclerotia produced by all isolates varied significantly concerning spectral RGB coefficient value (13.3-135.24). Four distinct patterns of sclerotial colour were observed i.e., light brown (RGB coefficient  $\geq 103$ ), brown (RGB coefficient = 73.3-103), dark brown (RGB coefficient = 43.3-73.3) and deep dark brown (RGB coefficient  $\leq 43.3$ ) (**Table 1**). Three (19%) isolates produced light brown pigmentation of sclerotia. In comparison, brown pigmentation was observed in five (38%) isolates, dark brown pigmentation was observed in nine (42%) isolates, and deep dark brown pigmentation was obtained in four (19%) isolates.

The time required for initiation of sclerotia formation of *R. solani* isolates varied between 36 – 96 hrs. Depending on the time taken for initiation of sclerotia formation of *R. solani*, all the isolates were classified into 3 groups viz., (I) fast growers (3), (II) moderate growers (13), and (III) slow growers (5) (**Table 1; Table 3**). However, the maximum number of sclerotia observed was 377 (RSV-9), while the minimum number of sclerotia was 22 (RSV-14). These results were consistent with the observations of several researchers (Yadumanet et al., 2019; Goswami et al., 2019; Kuiry et al., 2014). Similarly, Goswami et al. (2019) classified all the isolates into 4 groups, i.e., more, moderate, less, and absent. The maximum number (192) of sclerotia was produced in RSMRZ58 and RSMRZ63 isolates, and the time taken for initiation of sclerotia formation ranged from 4 to 6 days.

The location of each isolate was determined at 10 DAI and classified into two groups: surface sclerotia and surface and aerial sclerotia (**Table 3**). Sclerotia of seventeen (80.9%) isolates were located on the surface, and four (19%) isolates were found to be both on the surface and aerially located. These results were confirmed by Reddy et al. (2019).

Depending on the criterion, the clump formation of all isolates was recorded and divided into three groups (More, moderate, and absent). Among the 21 isolates, 10 isolates

showed more clump formation, 4 isolates showed moderate, while clump formation is lacking in 7 isolates. Our results were supported by Goswami et al. (2019), who reported a more significant number of clump formations observed in 36 isolates, moderate (36), less (9), and no clumps formed in 29 isolates (**Table 3**). Among 21 isolates, twelve (57%) isolates had secreted honeydew, whereas the other nine (43%) isolates did not secrete honeydew (**Table 1**). Similarly, Reddy et al. (2019) observed sclerotial secretion and categorised it into two groups, positive and negative.

Further studies on the characterisation of *R. solani* isolates revealed the existence of morphological variability in isolates with no persistent feature that is analogous to the origin, which the studies conducted by various workers confirm (Susheela and Reddy 2013; Kuiry et al., 2014; Goswami et al., 2019; Yaduman et al., 2019; Reddy et al., 2019).

Similarly, Kumar et al. (2008) isolated 25 *R. solani* isolates from various locations in eastern UP (India) and analysed their variability using morphological and virulent characteristics. Among the morphological features, diversity was recorded in hyphal growth and pattern of distribution, colour, size, and mass sclerotia on PDA media.

#### **Pathogenic variation**

Virulence analysis of 21 isolates was recorded on susceptible cv. PB-1 and found variation in the degree of virulence towards rice, which produced lesions on leaves, sheath, and stem of rice. Among all the isolates, twelve isolates (57.1%) showed low levels of infection. They were categorised as weakly virulent, whereas the remaining four isolates (19%) were virulent, while five isolates (23.80%) showed a high level of infection and were categorised as highly virulent. The range of relative lesion height varied from 13.9 to 77.7%. Moreover, maximum RLH% was depicted by RS-8 (77.7%), followed by RS-1 (68.3), while RS-13 showed the least value of RLH%. Pathotype WV, consisting of the most isolates, was dominant in the field population. The results of pathogenic variability did not show any correlation between isolates and their morphological analysis and geographical origins (**Table 4**).

The morphological and virulence diversity among *R. solani* AG-1 IA isolates could be associated with high genetic diversity, as disclosed earlier by Yugander et al., (2015), and Pavani and Singh (2018). Similarly, Kumar et al. (2008) revealed that highly virulent isolates are fast-growing with macro-sized sclerotia while slow-growing micro-sized sclerotia isolates are weakly virulent. Moreover, Goswami et al. (2019) explained the correlation between the relative lesion height and susceptibility index with a significant difference in PDI. The isolates were categorised into highly virulent (HV), moderately virulent (MV), virulent (V),

and weakly virulent (WV) groups and the highly virulent isolates predominated in the *R. solani* population with 33.3% depending on the percent disease index (PDI).

### **Molecular variability**

The RAPD-PCR had been successfully used for molecular characterisation of various *R. solani* isolates collected from different geographical locations. In our study, 2 RAPD markers yielded scorable and reproducible banding patterns (**Fig. 1; Fig. 2**).

### **Cluster analysis**

A combined data set of amplified bands were obtained for all isolates, and primers were analysed using the Unweighted Pair-Group Method (UPGMA) based cluster analysis with dissimilarities ranging from 1 – 13.85 %. A dendrogram was generated using pooled RAPD data which divided 21 isolates of *R. solani* into 2 major clusters, A and B (**Fig. 3**). Maximum isolates were grouped in cluster A with 19 isolates (90%). The first group consists of 19 isolates, further divided into two subgroups, A1 and A2. Subgroup A1 is further subdivided into two subclusters, A1-I and A1-II. Subgroup A1-I contained 8 isolates (RS-20, RS-19, RS-18, RS-17, RS-16, RS-13, RS-11, RS1) with 80% genetic similarity. Subgroup A1-II is formed from 10 isolates (RS-15, RS-14, RS-12, RS-9, RS-8, RS-7, RS-5, RS-4, RS-3, RS-2), all of which belonged to different locations but shared the similarity of 70% among isolates. While subcluster A2 is composed of only one individual solitary isolate, RS-21, which does not belong to AG1-IA. The two strains of *R. solani*, RS-10 and RS-6, did not produce any bands on the ITS region, did not share any of the groups, and formed a separate primary cluster B. The current study could also identify a clear pathway of no band formation in RS-21, which different anastomosis groups obtained.

Manjunatha et al. (2018) resolved the genetic structure of the isolates using 10 RAPD markers and revealed the average pairwise similarities in the range of 0.2 - 0.5, thus indicating considerable variation within the isolates. Interestingly, such a wide diversity was found only among the few isolates used in our study.

Sharma et al. (2005) used 11 RAPD markers to analyse 24 *R. solani* isolated from different locations and hosts and reported a similarity index of 0.16 – 0.53. The markers revealed the host-specific band profiles. However, our study did not correlate with virulence, geographical locations, and RAPD profile groupings. Similarly, Yi et al. (2002) also found no correlation between virulence and RAPD groupings.

Several studies have previously been conducted to assess various factors in *R. solani* using RAPD fingerprints by Neeraja et al. (2002a), Banerjee et al. (2012), Susheela and Reddy (2013) Lal et al. (2013), and Manjunatha et al. (2018). However, previous studies indicated

that the RAPD primers have potential as a tool for identifying isolates of rice sheath blight pathogen and enhance our understanding of the ecology and biology of these fungi by providing measurements of the relationship and genetic diversity of the isolates.

Although the primers and isolates used in our study were relatively small, they could establish molecular variability effectively among all the sheath blight isolates, proposing that RAPD can still be considered an efficient, reliable, and effective marker technology for detecting the genetic relatedness in *Rhizoctonia* spp.

### **Conclusion**

This study indicates that *R. solani* isolates have considerable variation in cultural, pathogenic, and molecular characteristics. Moreover, it shows a continuous evolution and pathogen adaptability. This ability of pathogenic fungus makes it even more damaging to the rice crop. The complex nature of the pathogen creates a problem in the description, examination, and management of the pathogen. This diversity analysis may develop further strategies for managing the disease.

UNDER PEER REVIEW

**Table 1** List of *Rhizoctoniasolani* AG-1 IA isolates from eastern Uttar Pradesh collected during the *Kharif*-2019 crop season and their morphological characterisation.

Isolates	Place	Geographical location	Sclerotia initiation (hrs)	No. of Sclerotia/Plate	(RGB values)		Honeydew formation
					Mycelium colour	Sclerotial colour	
RSV-1	Dhara	25.10'44"N 82.58'51"E	48	260.5	149.86	68.66	+
RSV-2	Kailahatt	25.8'55"N 82.57'22"E	72	139.5	137.73	95.85	-
RSV-3	Jalalpur	25.7'38"N 82.54'55"E	72	143	149.89	115.3	+
RSV-4	Pulwari	25.5'9"N 82.55'2"E	36	32	134.9	41.72	+
RSV-5	BHU	25.16'9"N 82.54'9"E	96	150	144.24	60.7	-
RSV-6	Khajuri	25.20'19"N 82.59'28"E	96	173	149.33	78.3	+
RSV-7	Ali Nagar	25.15'49"N 83.8'17"E	72	156.5	123.37	88.4	+
RSV-8	Ganja khwaja	25.15'57"N 83.11'54"E	72	60	119.11	135.4	-
RSV-9	Bichhiyakhurd	25.15'16"N 83.12'12"E	72	377	164.60	92.7	-
RSV-10	Sadalpura	25.17'45"N 83.12'12"E	72	214.5	134.27	67.1	+
RSV-11	Maudli	25.24'19"N 83.4'8"E	48	149	135.19	71.5	-
RSV-12	Satahara	25.8'33"N 82.71'18"E	72	129	157.57	121.2	-
RSV-13	SHUATS	25.42'11"N 81.84'13"E	72	311	121.01	52.2	-
RSV-14	Naini	25.38'96"N 81.88'79"E	96	22	153.49	54.6	+
RSV-15	Phaphamau	25.53'13"N 81.84'91"E	72	145.5	159.83	43.35	-
RSV-16	Dandupur	25.33'96"N 81.82'03"E	96	87	130.73	27.7	+
RSV-17	Saidanpur	25.71'93"N 82.66'32"E	72	84	176.45	51.7	+
RSV-18	Kalichabad	25.73'98"N 82.66'05"E	96	118	138.7	54.24	+
RSV-19	Wazidpur	25.72'91"N 82.68'21"E	72	144	162.38	89.26	-
RSV-20	Puarikala	25.43'92"N 82.92'33"E	72	84	137.27	13.29	+
RSV-21	Cholapur	25.47'40"N 83.00'53"E	72	93.5	130.59	14.08	+
C.D (5%)			7.74	20.13			

C.D- critical difference at 5%; RGB= red, green, blue; (+) present, (-) absent

**Table 2** Cultural characteristics of different isolates of *Rhizoctoniasolani* on PDA medium incubated at  $26\pm 2^{\circ}\text{C}$

Mycelial characteristics	Characteristics	Isolate(s) code	Number of isolates
<b>Mycelial growth rate (mm h<sup>-1</sup>)</b>	Fast (> 57.4 mm d <sup>-1</sup> )	RSV-5, RSV-6, RSV-12, RSV-15, RSV-18, RSV-21	6
	Moderate (41.9-49.7 mm d <sup>-1</sup> )	RSV-4, RSV-8, RSV-14, RSV-17, RSV-20	5
	Slow (<34.2 mm d <sup>-1</sup> )	RSV-1, RSV-2, RSV-3, RSV-7, RSV-9, RSV-10, RSV11, RSV-13, RSV-16, RSV-19	10
<b>Type of mycelial dispersion (5 DAI)</b>	Fluffy	RSV-1, RSV-2, RSV-3, RSV-6, RSV-7, RSV-10, RSV-11, RSV-12, RSV-14, RSV-15, RSV-21	11
	Appressed	RSV-4, RSV-8, RSV-9, RSV-13, RSV-16, RSV-17, RSV-18, RSV-19, RSV-20	9
	Aerial	RSV-5	1

**Table 3** Sclerotial characteristic of different isolates of *Rhizoctoniasolani* on PDA medium incubated at  $26\pm 2^{\circ}\text{C}$

Sclerotial characteristics	Characteristics	Isolate(s) code	Number of isolates
<b>a) Distribution pattern</b>	Peripheral	RSV-2, RSV-3, RSV-5, RSV-7, RSV-8, RSV-11, RSV-12, RSV-13, RSV-15, RSV-16, RSV-17	11
	Scattered	RSV-1, RSV-6, RSV-9, RSV-10, RSV-20	5
	Central	RSV-4	1
	Central and peripheral	RSV-14, RSV-18, RSV-19, RSV-21	4
<b>b) Time for sclerotia formation</b>	Fast	RSV-1, RSV-4, RSV-11	3
	Moderate	RSV-2, RSV-3, RSV-7, RSV-8, RSV-9, RSV-10, RSV-12, RSV-13, RSV-15, RSV17, RSV-19, RSV-20, RSV-21	13
	Slow	RSV-5, RSV-6, RSV-14, RSV-16, RSV-18	5
<b>c) Location</b>	Surface	RSV-1, RSV-3, RSV-4, RSV-5, RSV-6, RSV-7, RSV-8, RSV-9, RSV-10, RSV11, RS-13, RSV-15, RSV-17, RSV-18, RSV-19, RSV-20, RSV-21	17

	Surface and aerial	RSV-2, RSV-12, RSV-14, RSV-16	4
<b>d) Texture</b>	Smooth	RSV-1, RSV-6, RSV-7, RSV-10, RSV-11, RSV-13, RSV-14, RSV-15, RSV-16, RSV-18, RSV-19	11
	Rough	RSV-2, RSV-3, RSV-4, RSV-5, RSV-8, RSV-9, RSV-12, RSV-17, RSV-20, RSV-21	10
<b>e) Number (10 DAI)</b>	More (>183)	RSV-1, RSV-9, RSV-10, RSV-13	4
	Moderate (102-183)	RSV-2, RSV-3, RSV-5, RSV-6, RSV-7, RSV-11, RSV-12, RSV-15, RSV-18, RSV-19	10
	Less (<102)	RSV-4, RSV-8, RSV-14, RSV-16, RSV-17, RSV-20, RSV-21	7
<b>f) Honeydew secretion</b>	Present	RSV-1, RSV-3, RSV-4, RSV-6, RSV-7, RSV-10, RSV-14, RSV-16, RSV-17, RSV-18, RSV-20, RSV-21	12
	Absent	RSV-2, RSV-5, RSV-8, RSV-11, RSV-12, RSV-13, RSV-15, RSV-19	9

**Table 4** Grouping, the isolates of *Rhizoctoniasolanib* based on virulence on rice cultivar PB-1 under artificial inoculation conditions during the cropping season of 2019

Virulence pattern	PDI (%)	Isolates	No of isolates
Weakly virulent	<41.5	RSV-2, RSV-5, RSV-6, RSV-9, RSV-11, RSV-12, RSV-13, RSV-15, RSV-16, RSV-17, RSV-18, RSV-21	12
Virulent	41.5-71.89	RSV-4, RSV-10, RSV-19, RSV-20	4
Highly virulent	>71.89	RSV-1, RSV-3, RSV-7, RSV-8, RSV-14	5

PDI-Per cent disease index

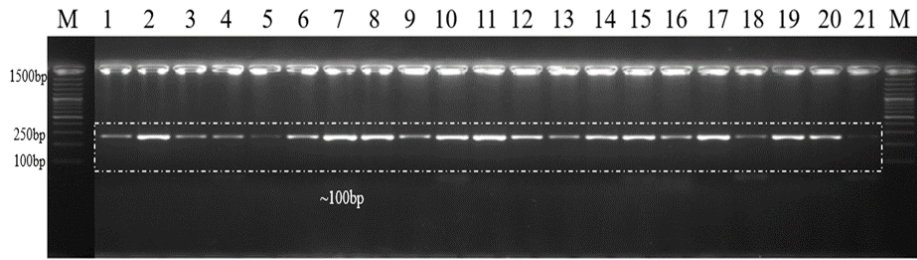

**Fig 1** DNA fingerprinting profiles of ITS1/ITS4 products of *Rhizoctoniaspp.* Showing bands of ~650-700bp; M – size marker (100 bp).

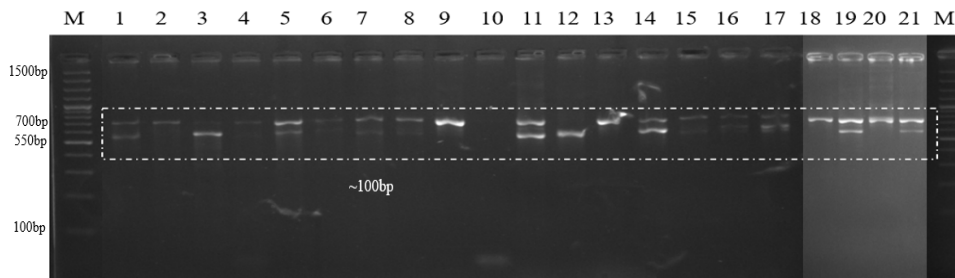

**Fig 2** Gel documentation of the resolved DNA products using the specific primers for *R. solani* AG1-IA. Isolates that belong to subgroup AG1-IA are expected to produce a band of ~265bp. Suspected *R. solani* isolates made a band size of ~250bp (Lanes 1-20). The suspected *R. oryzae-sativae* lane (21) did not produce ~250bp bands; M- size marker (100 bp).

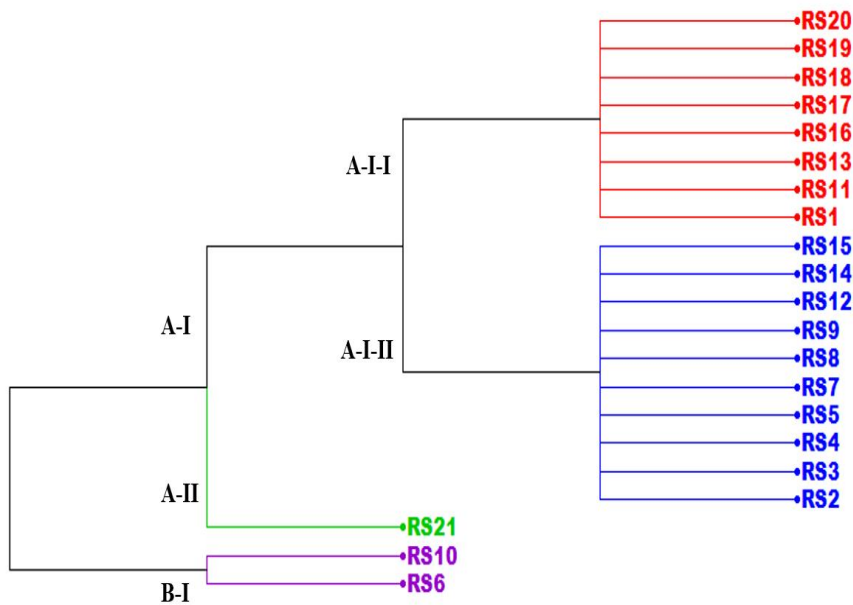

**Fig 3** RAPD-based dendrogram obtained from the combined data set of 21 *Rhizoctonia solani* isolates generated by Unweighted pair group method arithmetic mean (UPGMA) analysis.

## Declarations:

**Data availability statement:** All data generated or analysed during this study are included in this published article.

## References

- Banerjee S., Dutta S., Mondal A., Mandal N., Bhattacharya S. 2012. Characterisation of molecular variability in *Rhizoctoniasolani* isolates from different agro-ecological zones by random amplified polymorphic DNA (RAPD) markers. African Journal of Biotechnology 11(40): 9543-9548. DOI: [10.5897/AJB11.4197](https://doi.org/10.5897/AJB11.4197)
- Chakrabarti R.R., Majumdar N., Nath R. 2018. Sustainable Management of Rice Sheath Blight Disease through Antagonists, Fungicide and Soil Amendments. International Journal of Pure Applied Bioscience 6(5): 1005- 1009.
- FAO updates, 2018 available: [www.fao.org/wporldfoodsituation/csdb/en/](http://www.fao.org/wporldfoodsituation/csdb/en/)
- Ghosh S., Gupta S.K., Jha G. 2014. Identification and functional analysis of AG1-IA specific genes of *Rhizoctoniasolani*. Current genetics, 60(4): 327–341. <https://doi.org/10.1007/s00294-014-0438-x>
- Gonzalez-Vera A.D., Bernardes-de-Assis J., Zala M., McDonald B.A., Correa-Victoria F., GraterolMatute E.J. 2010. Divergence between sympatric rice and maize-infecting populations of *Rhizoctoniasolani* AG1 IA from Latin America. Phytopathology 100: 172-182.
- Goswami S., Singh V., Kashyap P.L., 2017. Population genetics structure of *Rhizoctoniasolani* AG1IA from a rice field in North India. Phytoparasitica. 45:299–316.
- Goswami S., Singh V., Kashyap P., Singh P.K. 2019. Morphological characterization and screening for sheath blight resistance using Indian isolates of *Rhizoctoniasolani* AG1IA. Indian Phytopathology. 72. 1-18. [10.1007/s42360-018-0103-2](https://doi.org/10.1007/s42360-018-0103-2).
- GRiSP (Global Rice Science Partnership). 2013. Rice almanac, 4<sup>th</sup> edition. Los Banos (Philippines): International Rice Research Institute. 283 p.
- Gurav N.P., Mehta N.K., Singh S., Basavaraj K. 2018. Cultural, Morphological Variability and Anastomosis behavior in *Rhizoctoniasolani* isolate causing Sheath blight of Rice. Journal of Mycology and Plant Pathology. 7(7): 2438-2445.
- India statistics updates, 2018 available: [www.indiastat.com](http://www.indiastat.com)
- Kuiry S.P., Mondal A., Banerjee S., Dutta S. 2014. Morphological variability in *Rhizoctoniasolani* isolates from different agro-ecological zones of West Bengal,

Formatted: Font: Not Bold

- India, Archives of Phytopathology and Plant Protection, 47:6, 728-736, DOI: [10.1080/03235408.2013.820388](https://doi.org/10.1080/03235408.2013.820388)
- Kumar K.V.K., Reddy M.S., Klopper J.W., Lawrence K.S., Groth D.E., Miller M.E. 2009. Sheath blight disease of rice (*Oryza sativa* L.) an overview. Bioscience Biotechnology Research Asia, 6:465–480.
- Kumar M., Singh V., Singh N., Vikram P. 2008. Morphological and virulence characterization of *Rhizoctoniasolani* causing sheath blight of rice. Environmental Ecology. 26 (3): 1158-1166.
- Lal M., Singh V., Kandhari J., Sharma P., Kumar V., Murti S. 2014. Diversity analysis of *Rhizoctoniasolani* causing sheath blight of rice in India. African Journal of Biotechnology, 13(51): 4594-4605.
- Lee S.B., Milgroom M.G., Taylor J.W. 1988. A rapid, high-yield mini-prep method for isolation of total genomic DNA from fungi. Fungal Genet News. 35: 23–24.
- Li L., Zhang Q., Huang D. 2014. A review of imaging techniques for plant phenotyping. Sensor 14:20078–20111.
- Linde C.C., Zala M., Paulraj R.S.D., McDonald B.A., Gnanamanickam S.S. 2005. Population structure of the rice sheath blight pathogen *Rhizoctoniasolani* AG-1 IA from India. European Journal of Plant Pathology, 112(2): 113-121. DOI: [10.1007/S10658-005-1753-3](https://doi.org/10.1007/S10658-005-1753-3).
- Lore J.S., Jain J., Hunjan M.S., Gargas G., Mangat G.S., Sandhu J.S. 2015. Virulence spectrum and genetic structure of *Rhizoctonia* isolates associated with rice sheath blight in the northern region of India. European Journal of Plant Pathology 143: 847–860. <https://doi.org/10.1007/s10658-015-0736-2>
- Manjunatha O., Sagar V., Prakasam V., Reddy C.N. 2018. Variability Studies on Sheath Blight of Rice in Karnataka. International Journal of Current Microbiology and Applied Sciences. 7(10): 724-736. DOI: <https://doi.org/10.20546/ijcmas.2018.710.080>
- Margani R., Hadiwiyono H., Widadi S. 2018. Utilizing Bacillus to inhibit the growth and infection by sheath blight pathogen, *Rhizoctoniasolani* in rice. IOP Conference Series: Earth and Environmental Science. 142. 012070. DOI: <https://doi.org/10.1088/1755-1315/142/1/012070>.
- Matsumoto M., 2002. Trials of direct detection and identification of *Rhizoctoniasolani* AG 1 and AG 2 subgroups using specifically primed PCR analysis. Mycoscience, 43(2): 185-189. DOI: <https://doi.org/10.1007/S102670200>

- Mew T.W., Leung H., Savary S., Vera Cruz C, M., Leach J.E. 2004. Looking Ahead in Rice Disease Research and Management, Critical Reviews in Plant Sciences, 23(2): 103-127, DOI: <https://doi.org/10.1080/07352680490433231>
- Misawa T., Kurose D. 2019. Anastomosis group and subgroup identification of *Rhizoctoniasolani* strains deposited in NARO Gene-bank, Japan. Journal of General Plant Pathology. 85: 282-294. <https://doi.org/10.1007/s10327-019-00848-8>.
- Mishra P.K., Gogoi R., Singh P.K., Rai S.N., Singode A., Kumar A., Manjunathan C. 2014. Morpho-cultural and pathogenic variability in *Rhizoctoniasolani* isolates from rice, maize, and green gram. Indian Phytopathology. 67(2): 147-154.
- Molla K.A., Karmakar S., Molla J., Bajaj P., Varshney R.K., Datta S. K., Datta K. 2020. Understanding sheath blight resistance in rice: the road behind and the road ahead. Plant Biotechnology Journal, 18(4), 895–915.
- Naveenkumar R., Muthukumar A., Sangeetha G., Mohanapriya R. 2017. Developing Eco-friendly biofungicide for the management of major seed-borne diseases of rice and assessing their physical stability and storage life. ComptesRendusBiologies 340:214–225.
- Naveenkumar R., Singh V., Singh P.K., Anandan A. 2021. Pattern of genetic variation in rice (*Oryzasativa* L.) population for sheath blight resistance over the seasons. Indian Journal of Genetics, 81(1): 132-134.
- Neeraja C.N., Shenoy V.V., Reddy C.S.,Sarmag N.P. 2002a. Isozyme polymorphism and virulence of Indian isolates of the rice sheath blight fungus. Mycopathologia. 156 (2): 101-108.
- Neha K.V., Naveenkumar R., Balabaskar P., Pakkirisamy M. 2017. Evaluation of fungicides against sheath blight of rice caused by *Rhizoctoniasolani* (Kuhn.). ORYZA- An International Journal on Rice. 54. 470.
- Parengam M.,Judprasong K.,Srianujata S.,Jittinandana S.,Laoharajanaphand S.,Busamongko A. 2010. Study of nutrients and toxic minerals in rice and legumes by instrumental neutron activation analysis and graphite furnace atomic absorption spectrophotometry. Journal of Food Composition and Analysis. 340–345. 10.1016/j.jfca.2009.12.012.
- Pavani S.L., Singh V. 2018. Assessment of Virulence Diversity of *Rhizoctoniasolani* Causing Sheath Blight Disease in Rice from Eastern UP. Current Journal of Applied Science and Technology. 26(6): 1-10.

- Prakasam V., Ladhakshmi D., Laha G.S, Krishnaveni D., Sheshu M.M., JyothiBadri, SrinivasPrasad M., Viraktamath B.C. 2013. Sheath blight of rice and its management. Technical Bulletin No. 72, Directorate of Rice Research(ICAR), Rajendranagar.
- Reddy B.D., Sagar B.V., Sridevi G.,Prakasam V. 2019. Variability among *Rhizoctoniasolani* inciting rice sheath blight from different agro-climatic zones of Telangana state. *Journal of Mycology and Plant Pathology*. 49(1): 56-66.
- Richa K., Tiwari I.M., Kumari M., Devanna B.N, Sonah H., Kumari A., Nagar R., Sharma V., Botella J.R., Sharma T.R. 2016. Functional Characterization of Novel Chitinase Genes Present in the Sheath Blight Resistance QTL: qSBR11-1 in Rice Line Tetep. *Frontiers of Plant Science*. 7:244. doi: 10.3389/fpls.2016.00244
- Sandoval R.F.C., Cumagun C.J.R. 2019. Phenotypic and Molecular Analyses of *Rhizoctonia* spp. Associated with Rice and Other Hosts. *Microorganisms*. 7. 88. <https://doi.org/10.3390/microorganisms7030088>
- Sharma M., Gupta S.K., Sharma T.R. 2005. Characterization of variability in *Rhizoctoniasolani* by using morphological and molecular markers. *Journal of Phytopathology*. 153: 449-456.
- Sharma N.R., Teng P.S., Oliver F.M. 1990. Comparisons of assessment methods for rice sheath blight disease. *Philippines. Phytopathology*. 26:20-24.
- Singh R., Sunder S., Kumar P. 2016. Sheath blight of rice: current status and perspectives. *Indian Phytopathology*, 69(4), 340-351.
- Sundravadana S., Thirumurugan S., Devadason A. 2011. Exploration of Molecular Variability in *Rhizoctoniabataicola*, the Incitant of Root Rot Disease of Pulse Crops. *Journal of Plant Protection Research*. 51(2): 184-189. <https://doi.org/10.2478/v10045-011-0032-x>
- Susheela K., Reddy C.S. 2013. Variability in *Rhizoctoniasolani* (AG-11A) isolates causing sheath blight of rice in India. *Indian Phytopathology*. 66 (4): 341-350.
- Tuncer S., and Eken C. 2013. Anastomosis grouping of *Rhizoctoniasolani* and Binucleate *Rhizoctonia* spp. isolated from Pepper in Erzincan, Turkey. *Plant Protection Science*. 49. 127-131. <https://doi.org/10.17221/77/2012-PPS>
- Uppala L., and Zhou X. 2018. Rice Sheath Blight. *Plant Health Instructor*. <https://doi.org/10.1094/PHI-I-2018-0403-01>
- White T., Bruns T., Lee S., Taylor J., Innis M., Gelfand D., Sninsky J. 1990. Amplification and Direct Sequencing of Fungal Ribosomal RNA Genes for Phylogenetics. *PCR Protocols*, Academic Press, 315-322.

- Wu Z.H., Wang T.H., Huang W., Qu Y.B. 2001. A simplified method for chromosome DNA preparation from filamentous Fungi. *Mycosystema*20, 575–577.
- Yang G., and Li C. 2012. General description of *Rhizoctonia* species complex. In: Cumagun CJ (ed) *Plant Pathology*, pp 41–52
- Yellareddygar S.K.R., Reddy M.S., Kloepper J.W., Lawrence K.S., Fadamiro H. 2014. Rice sheath blight: A review of disease and pathogen management approaches. *Journal Plant Pathology and Microbiology*. 5: 241
- Yi R.H., Liang C.Y., Zhu X.R., Zhou E.X. 2002. Genetic diversity and virulence variation of rice sheath blight pathogen (*Rhizoctoniasolani* AG-1 IA) from different rice varieties. *Journal of South China Agricultural University*. 23:22–26
- Yugander A., Ladhakshmi D., Prakasham V., Mangrauthia S.K., Prasad M.S., Krishnaveni D., Madhav M.S., Sundaram R.M., Laha G.S. 2015. Pathogenic and genetic variation among the isolates of *Rhizoctoniasolani* (AG-1 IA), the rice sheath blight pathogen. *Journal of Phytopathology*.163: 465-474.

UNDER PEER REVIEW