

## A Review of linear Fresnel collector receivers used in solar thermal technology

### Abstract

Linear Fresnel collectors (LFC) have, among the four technologies of concentrating solar power (CSP), the simpler technology. They have a one axis sun tracking, plane mirrors and a fix receiver. All these elements make them the most suitable for small scales CSP plants adapted to rural area of the Sub-Saharan region. The receiver is an important part of the LFC. There is a wide variety of receivers that differ in the shape of the absorber: mono-tube, multi-tube, plane. The shape of the secondary concentrator or its absence allows to categorize the receivers in a butterfly, compound parabolic concentrator, segmented parabolic secondary concentrator or trapezoidal receiver. Vacuum mono-tube receivers have heat losses between 200 W/m and 270 W/m at an absorber temperature of 350°C. A mono tube receiver at partial vacuum losses more than 350 W/m at 350°C. The lowest heat losses of a multi-tube receiver with a trapezoidal secondary concentrator can reach 500 W/m at an absorber temperature of 350°C. This paper discusses a comparative study of existing receiver designs in order to find the most suitable for rural areas in the sub-Saharan region, i.e. easy to design by hand and low cost. Although they do not have the best thermal performance, trapezoidal receivers with a black-painted copper multi-tube absorber and a glass cover seem to be the most suitable.

**Keywords:** Concentrating solar power (CSP), linear Fresnel collector (LFC), receiver, rural area, thermal losses.

Nomenclature		
CAPEX		Capital expenditure
CSP		Concentrating Solar Power
CPC		Compound Parabolic Secondary Concentrator
CLFR		Compact Linear Fresnel Reflector
LFC		Linear Fresnel Collector
OPEX		Operating expenses
PDS		Parabolic Dish Systems
PTC		Parabolic Trough Collector
SPT		Solar Power Tower
SLFR		scalable linear Fresnel reflector

## I. Introduction

The solar thermal technology includes processes like solar space heating, solar cooking, solar water heating, concentrating solar power. The concentrating solar power (CSP) technology allows to convert solar radiation to a high heat source and then used that heat for electricity generation, cooling, water desalination and cooking [1]. The most popular CSP is large-scale, more than 500 kW<sub>e</sub>, but small scales CSP, less than 500 kW<sub>e</sub>, are also available [2]. Among the most common CSP technologies, including parabolic dish systems (PDS), parabolic

trough collector (PTC), solar power tower (SPT) and linear Fresnel collector (LFC), the LFC appears the most suitable for rural areas of the Sub-Saharan region of Africa more precisely in their socio-economic context. The region has a young population, so a higher labour force. By their socio-economic context, we mean that they are low-income countries. In fact, according to World Bank Group's classification, there are twenty-seven (27) low-income countries, fourteen (14) lower-middle-income countries, and seven (7) upper-middle-income countries in the Sub-Saharan region. This work has been carried out in order to find the most appropriate receiver for an efficient and low-cost small scale LFC that may be built using material available in West Africa by local labor. In fact, LFC has a simplified technology, the lowest operating expenses (OPEX) cost among CSP and an important Capital expenditure (CAPEX) reduction potential [1,3,4]. LFC technology proved itself with more than nine large-scale power plants in operation and two power plants under construction in 2022 [5].

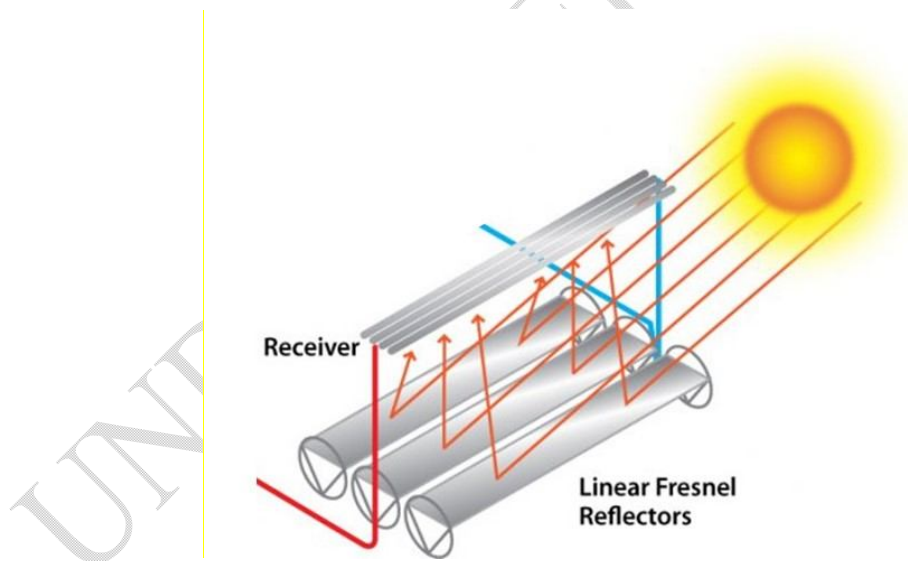

Figure 1: A LFR overview [6].

An LFC, as shown in Figure 1, consists of three parts: the concentrator, the receiver, and the sun tracker. It is the combination of their action that converts solar radiation into heat. There are two families of LFC type: collectors with a single receiver, this is the standard and most

widespread technology, and collectors with at least two receivers called Compact Linear Fresnel Reflector (CLFR) [7–10].

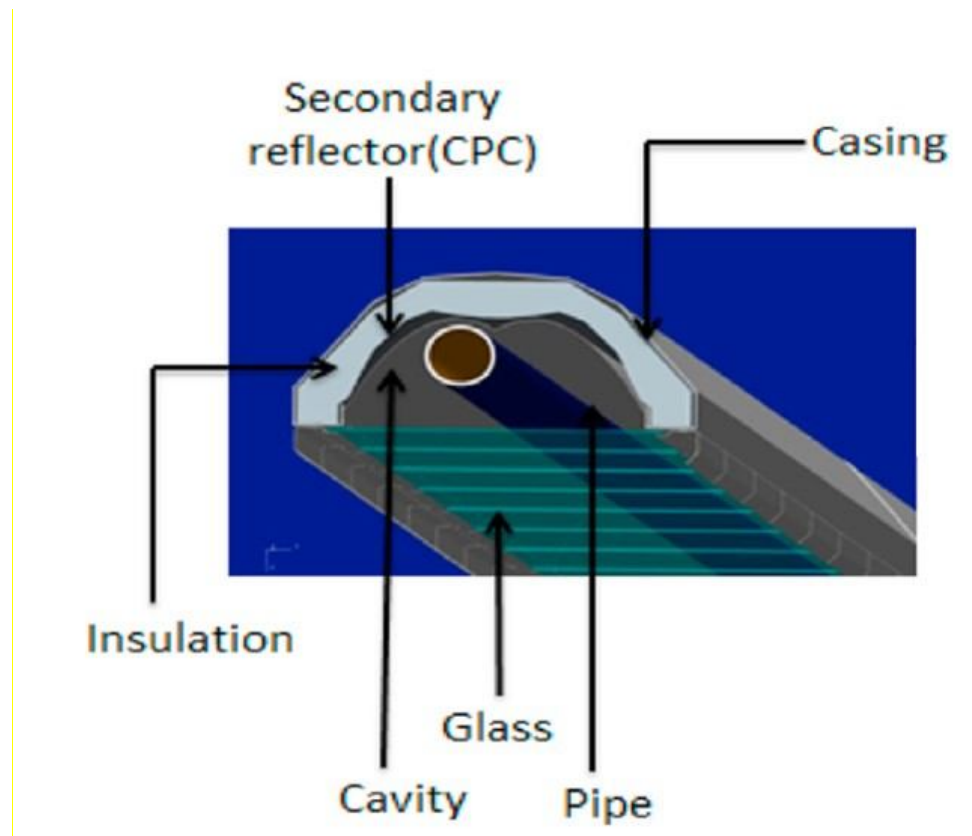

Figure 2. Receiver for LFC with secondary concentrator [11]

The absorber, the secondary concentrator, the thermal insulation and a protective envelope (casing) are the main elements found in a receiver Figure 2. The receiver is a combination of all these elements [12–14]. The operation of a receiver can be summarized as follows. Mirrors of the concentrator focus incident sun beams on the receiver precisely on absorber; there the radiation is converted as heat and then transfer by conduction and convection to heat transfer fluid (HTF) that going through the absorber. The Absorber is the heart of the receiver where heat exchange occurs. There are different shapes of the absorber: mono-tube, multi-tube or plane [7,13,15–23]. Each shape has advantages and drawbacks related to both heat transfer from the absorber to the HTF and heat losses. Temperature in absorber can reach 400 °C in

LFC; due to that high temperature there are significant heat losses. Radiative heat losses are the most important [80-90%] [14,24] followed by convective and conductive heat losses. [21,25,26]. The percentage of radiative losses can be explained by temperature on the absorber. A hot body emits radiation in infrared wavelengths the amount of energy emitted is functioning of body emissivity and its temperature; because of its high temperature absorber emits a lot on the infrared wavelength. The difference between absorber temperature and ambient temperature around absorber are factors of convective losses. Conductive losses are due to contact between absorber and the metallic part of the receiver. In addition to heat losses, there are optical losses, when some part of the reflected sun beam missed absorber. In order to reduce all these losses on the absorber, some elements are added to the absorber. A secondary concentrator is usually used to reduce optical losses. It allows to refocus on absorber the reflected sun beams that have already missed it. The secondary concentrator also allows to homogenize the distribution of the reflected sun beam on the absorber. It can take different shape, but all of them must be adapted to absorber shape [27]. Selective properties of glass are used to reduce radiative heat losses. The use of glass covers or glass envelopes creates a partial vacuum that reduces convection. Insulation is put between secondary concentrator and the metallic part of the receiver in order to reduce heat losses by conduction [28]. Absorber can be horizontal or vertical [8,29–32] but most of the time absorber has a horizontal position. A vertical absorber receives radiation on both sides without a secondary concentrator. The left side receives concentrated sun beam from left of the concentrator and right side of the right of the concentrator. Mathur, Negi [29,30] and Mills [7] studied a vertical receiver with respectively plane and Dewar tubes absorbers. The effects of absorber orientation are explained in the section : 'Receivers with plan absorbers'. Reflector's mirrors width and position influence the width of the absorber. There are two ways as to design a collector. When the shape of the receiver is imposed, the concentrator must be adapted to that

particular receiver; mirrors width and position are choosing in order that each incident sun beam must be reflected on the absorber. Mirrors have different widths and different shifts between consecutive mirrors. In the second approach the absorber, width is chosen according to mirrors of reflector width they must be more or less equal. Mirror width is the same for all. When mirrors have equal width, absorber width must be approximately the same. In fact, under good concentration conditions, the reflected image has a width identical to that of the mirrors [3,7,8,10]. The receiver optimal height and its impact on collector total efficiency are the he subject of considerable scientific research [30,33–35]. Receiver height is a function of the concentrator width; they are joint by an optical ratio: (half of concentrator width) / (receiver height) and excessive height of the receiver gives a spread reflected image on the receiver so important optical losses [30]. The optical ratio has been investigated by researchers; the ratio must: (= 1) [30], (<1.2) [34], (<1.75) [33]. In this paper, we will focus on different types of receivers that have been modeled [4,12] and experimented [9,13,14] according to their absorber shape and material.

## II. Design and layout of receivers of linear Fresnel collectors

### i. Receivers with mono-tube absorber

Tubular absorber is the most used in LFC systems. The absorber tube can be at ambient pressure, under partial vacuum or under vacuum. Stainless steel or aluminium tubes covered with a selective coating are the typical materials used in vacuum absorbers. The absorber tube is then surrounded by glass envelope; between the absorber tube and the glass envelope, there is a vacuum. At each end, a glass-to-metal sealing element and a bellows allow to keep the vacuum. Vacuum absorber tubes are commercialized by Schott Solar CSP, Siemens Solar Power (formerly Solel Solar Systems), Huiyin Group, Gear Solar and Archimede Solar

Energy. The vacuum tubes are standardized: tube diameter ~ 70 mm, glass envelope diameter ~120 mm length 4.06 m. the absorber tubes are placed in series to reach the total length of the concentrator. The heat losses are in the range of 70 W/m to 250 W/m at 250 °C - 400 °C [36]. The vacuum absorber tubes are mostly used for parabolic trough collectors where the receiver moves according to sun position. This restriction forces manufacturers to make lightweight absorber; in the case of LFC, receiver does not move so evacuated absorber for LFC will therefore be less expensive. In order to reduce heat and optical losses, a secondary concentrator of different shape can be used. Nevertheless, a receiver with vacuum absorber avoid using glass cover. Ambient or partial vacuum absorber tubes are not commercialized; they are manufactured with copper, stainless steel, aluminium tube. They are not standardized, each manufacturer making his own absorber. The tube is most of the time covered with a selective coating, a glass plate, insulation and a secondary concentrator to reduce heat and optical losses respectively. The secondary concentrators also increase the concentration ratio [37]. They are made of reflective material such as silvered-glass mirror or aluminium reflectors [37]. There are alternative of secondary concentrator shape adapted for vacuum or non-vacuum absorber.

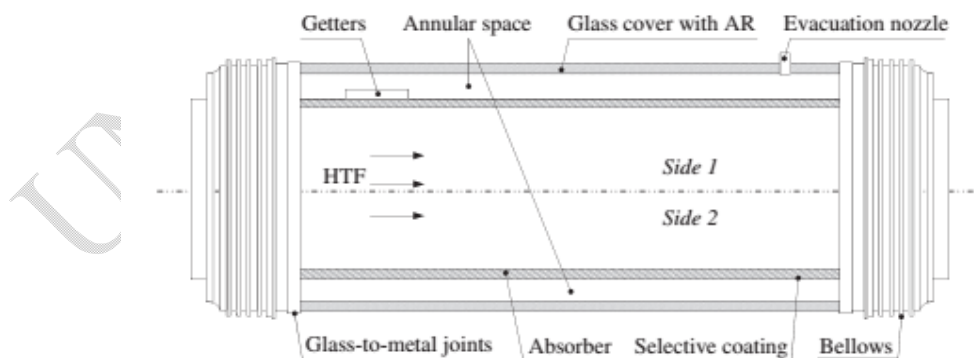

Figure 3: vacuum absorber tube [38].

a. Without secondary concentrator

A tubular absorber under partial vacuum without a secondary concentrator was tested by Negi et al.[39]. The partial vacuum was provided by a tubular glass envelope. The heat losses, in the prototype by Negi et al.[39], were [4-12 W/m<sup>2</sup>/ C] at [0-120 °C]. The vacuum and partial vacuum tubular absorber was experimented by Choudhury et al. [15]. They achieved a stagnation temperature of 385 °C for the vacuum absorber and 360°C for the partial vacuum absorber at 600 W/m<sup>2</sup> with a concentration ratio of 18. Zhu et al. [40] developed a scalable linear Fresnel reflector (SLFR) in order to reduce optical losses due to shading, blocking and end losses; they also experimented with a vacuum absorber without secondary concentrator [40]. They achieved a global efficiency, useful heat gain divided by incident radiation of the aperture area of the SLFR, of about 64 % for an average direct normal insolation of 858 W/m<sup>2</sup>.



Figure 4. Tubular receiver without secondary concentrator [39].

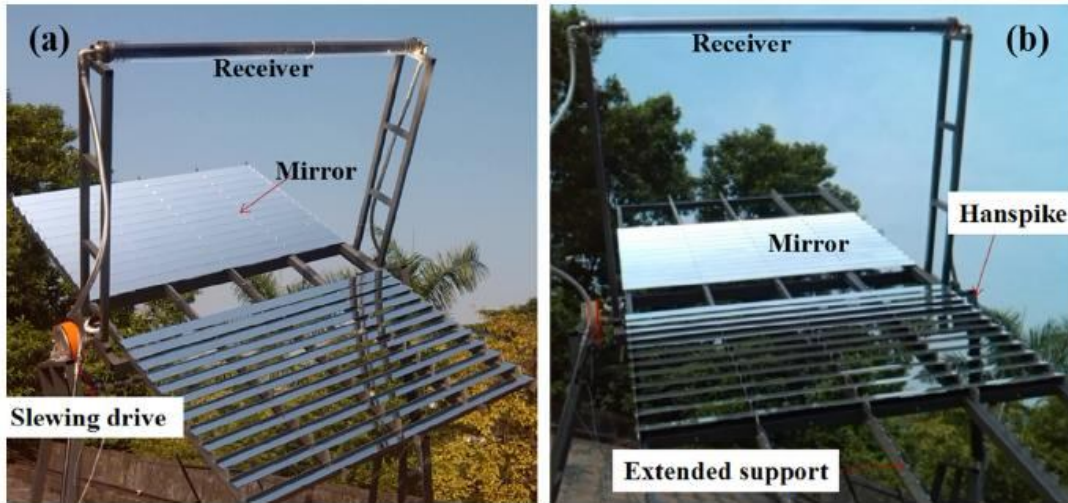

Figure 5. SLFR with a vacuum absorber as receiver [40].

a. Secondary concentrator with two parabolic wings or Butterfly secondary concentrator

This type of secondary concentrator enables a uniform distribution of the concentrated radiation on each side of the absorber; however, secondary concentrators with two parabolic wings can only be used with a vacuum absorber tube. This is because the shape of the secondary concentrator does not allow the use of a glass cover or insulation. Each wing receives the concentrated radiation from opposite sides of concentrator and reflects it onto the corresponding upper side of the absorber. The bottom side of the absorber receives the radiation from the concentrator. Grena et al. [33] explained the design of this secondary concentrator; it is patterned and under development for commercialization. The width of the concentrator and the height of the receiver must be considered when designing the secondary concentrator. This secondary concentrator allows for a wide concentrator for the same height of absorber, thus a higher concentration factor.

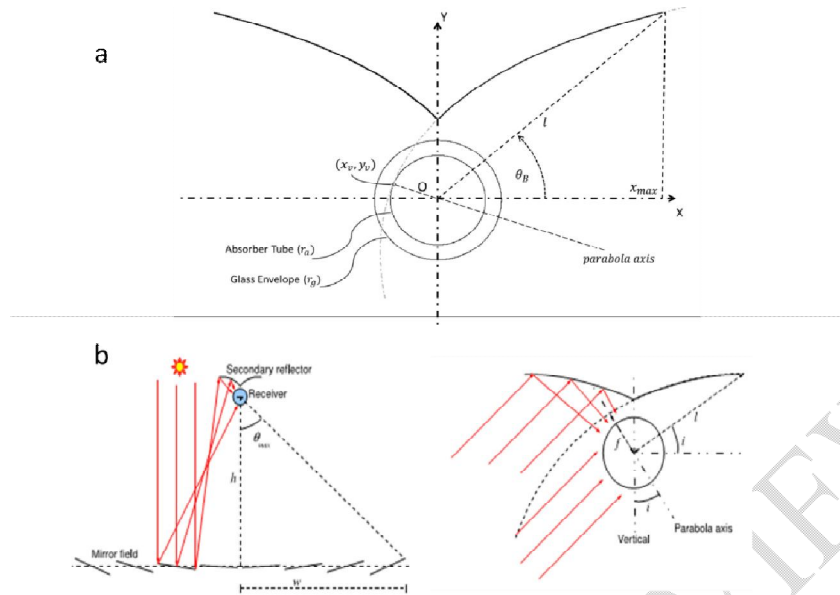

Figure 6: vacuum tubular absorber with butterfly secondary concentrator: a)[41] b) [33].

b. Secondary concentrator with trapezoidal shape.

Trapezoidal secondary concentrator also know trapezoidal concentrator [42] can be used with a vacuum, partial evacuated or with non-vacuum tubular absorber. When the non-vacuum tubular absorber is used, a glass cover is placed at the bottom of the trapezoidal cavity to reduce heat loss through the vacuum in the annulus [43]. There are a many trapezoidal secondary concentrators; some allow uniform distribution of the radiation over the absorber [44] Figure 7, Figure 8 and Figure 9 [27]; others are used to refocus the missed sun beam on the principal concentrator and protect absorber from convective heat losses Figure 10, [45]. Secondary concentrators are designed by considering the absorber and the principal concentrator.

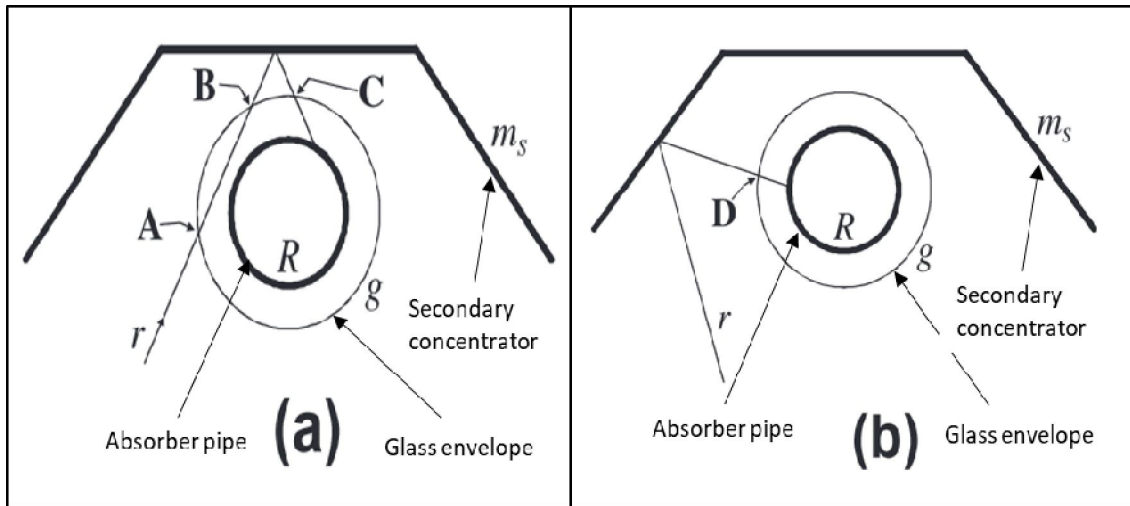

Figure 7. Mono-tube absorber with trapezoidal secondary concentrator used to refocus on absorber sun ray that missed the absorber after a first reflection on principal concentrator [40].

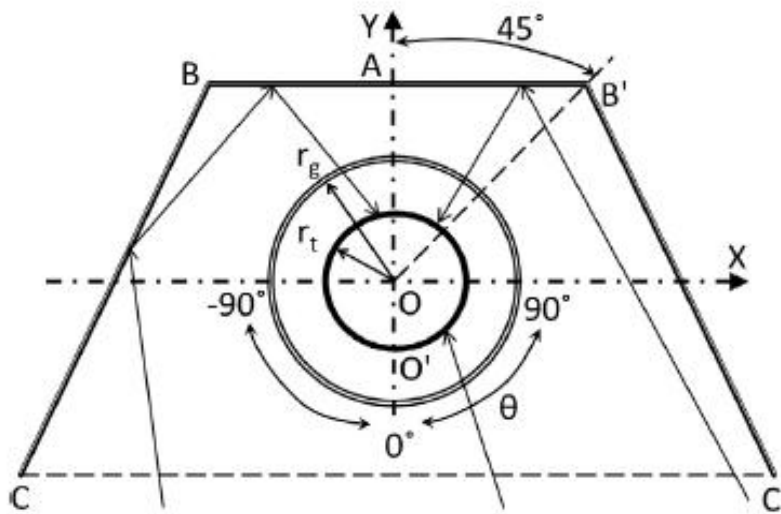

Figure 8. Mono-tube absorber with trapezoidal secondary concentrator used to refocus on absorber sun ray that missed the absorber after a first reflection on principal concentrator [42]

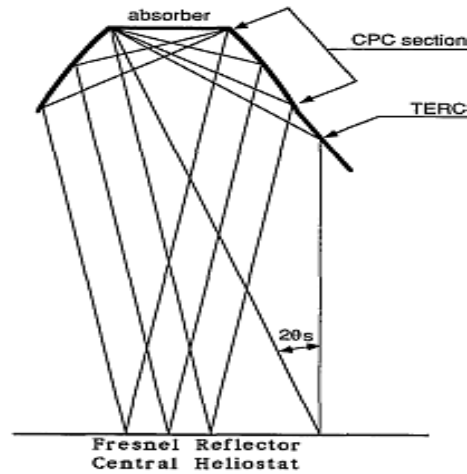

Figure 9. Gordon et al. trapezoidal secondary concentrator [27].

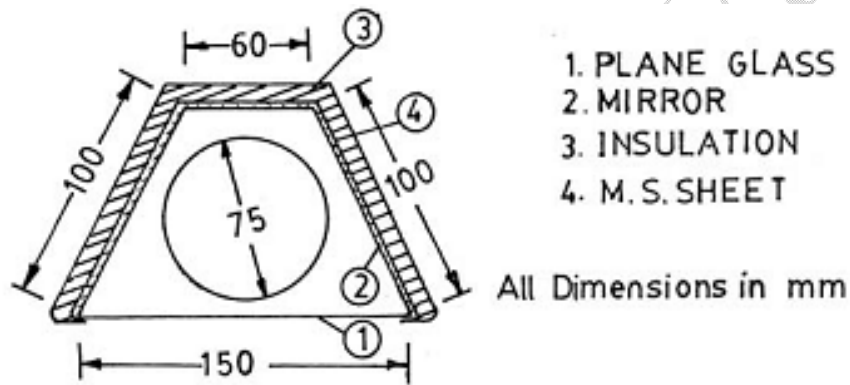

Figure 10: Non-vacuum mono-tube absorber with trapezoidal secondary concentrator and glass cover [45].

c. Compound parabolic secondary concentrator

Compound parabolic secondary concentrator (CPC) and butterfly secondary concentrator have several things in common, but CPC can be used with any type of absorber: vacuum or non vacuum Figure 11 and Figure 12. The parabolic secondary concentrator is less flat than the butterfly secondary concentrator so we can add a glass cover underneath in order to reduce convective heat losses. The glass cover can be a glass plate or glass envelope Figure 13. However, the receiver must be large, so we have a lot of convective heat losses [25]. There are a many methods to design an efficient CPC the absorber, the principal

concentrator, and the acceptance **angle** must be considered for CPC design. The upper part of the CPC can be open or closed in fact it does not work [25]. This secondary concentrator used to irradiate the upper of absorber Figure 14. The principal element of **the** CPC is the acceptance **angle** which depends on receiver height and the half-width of the concentrator. A small acceptance angle makes a depth secondary concentrator. **The** recommended acceptance **angle** must be greater than  $30^\circ$  [25]. Nevertheless, there are still important decisions to be made in the design of the receiver, such as whether to use one large tube or many thinner tubes (multi-tube receiver). The prototype built at Plataforma Solar de Almeria (PSA) by DLR and Solarmundo – later called Solar Power Group – [46] uses a one tube receiver, with a secondary concentrator above and a window below. Similarly, Novatec Solar, another Germany company, used such technology for commercial power plants PE1 and PE2 in Spain [46]. On the other hand, Ausra – later acquired by Areva Solar – built the Kimberlina power plant in California in 2008, with an open air multi-tube receiver [47]. The eLLO plant built by SUNCNIM in France consists of a mono-tube absorber with a CPC secondary receiver and a glass plate [47,48].

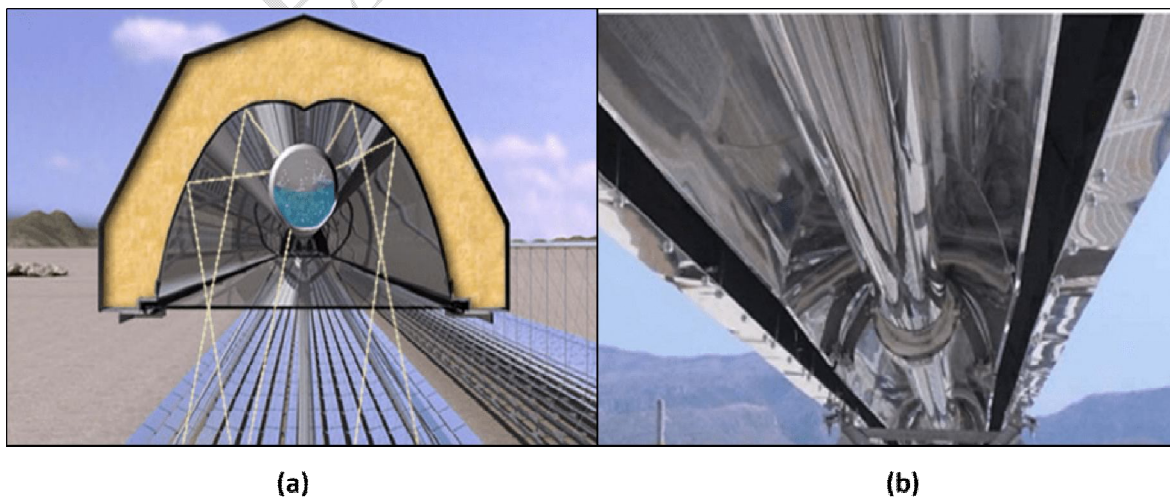

Figure 11. Mono-tube receiver of Novatec Solar with CPC secondary concentrator a) Nova-1 non- vacuum absorber used for Puerto Errado 2 power plant [46], b) Supernova with vacuum absorber

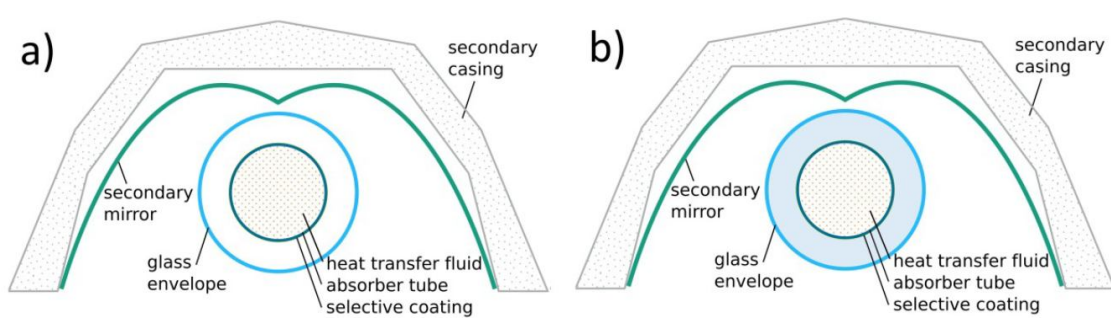

Figure 12: Mono-tube receiver with CPC secondary concentrator a) non- vacuum absorber, b) vacuum absorber [49].

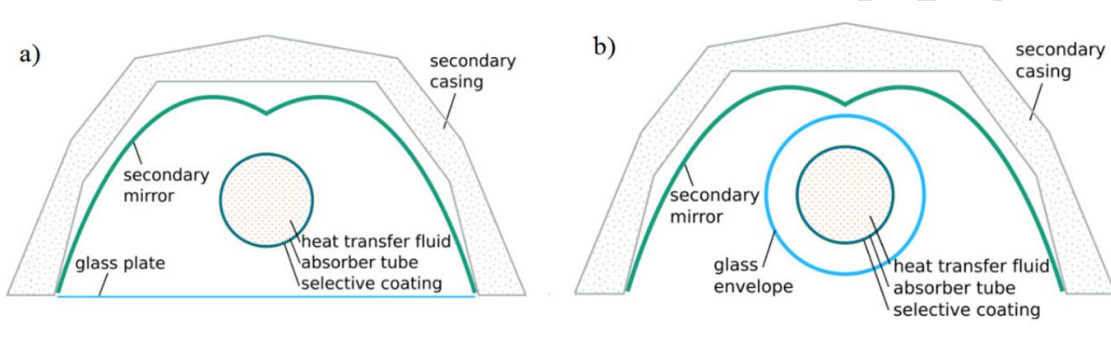

Figure 13: Receiver with CPC secondary concentrator a) glass plate cover; b) glass envelope cover [50].

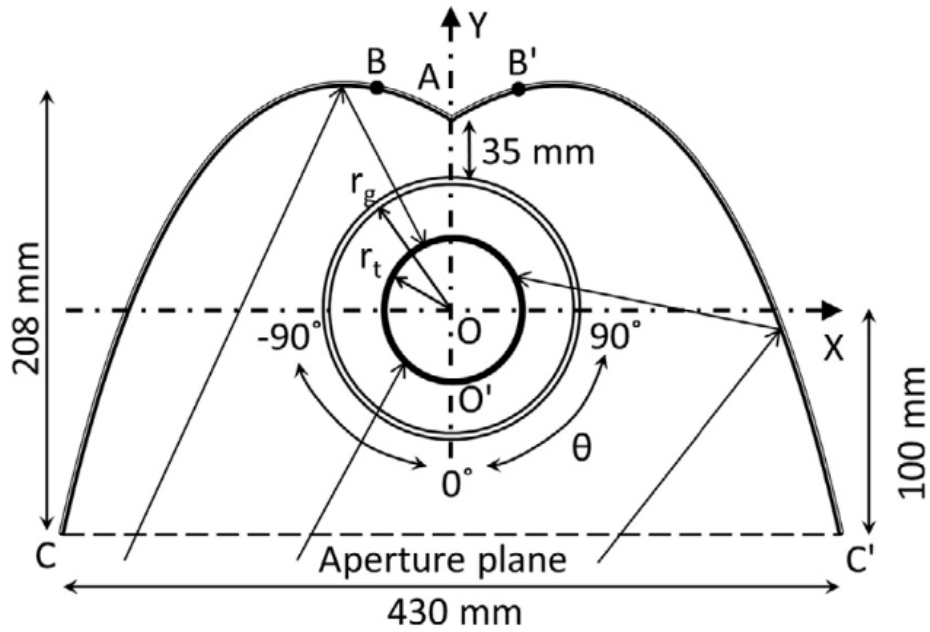

Figure 14. Receiver with CPC secondary concentrator allowing to irradiate the upper of absorber [42]

Montes et al. [51] developed a hybrid receiver with non-evacuated and evacuated receivers put in series with a CPC secondary concentrator. The non-evacuated receivers are used at the beginning of the collector when the heat transfer fluid is not very hot, so radiative losses are low and then evacuated receivers are used at the end when heat transfer fluid is not very hot. They do not use a glass cover at the bottom of the cavity.

A novel Segmented Parabolic secondary Concentrator (SPC) shape has been developed by Chaitanya Prasad et al. [42]. It is a combination of trapezoidal and Compound parabolic concentrator. They conclude that the highest optical efficiency is obtained for the SPC.

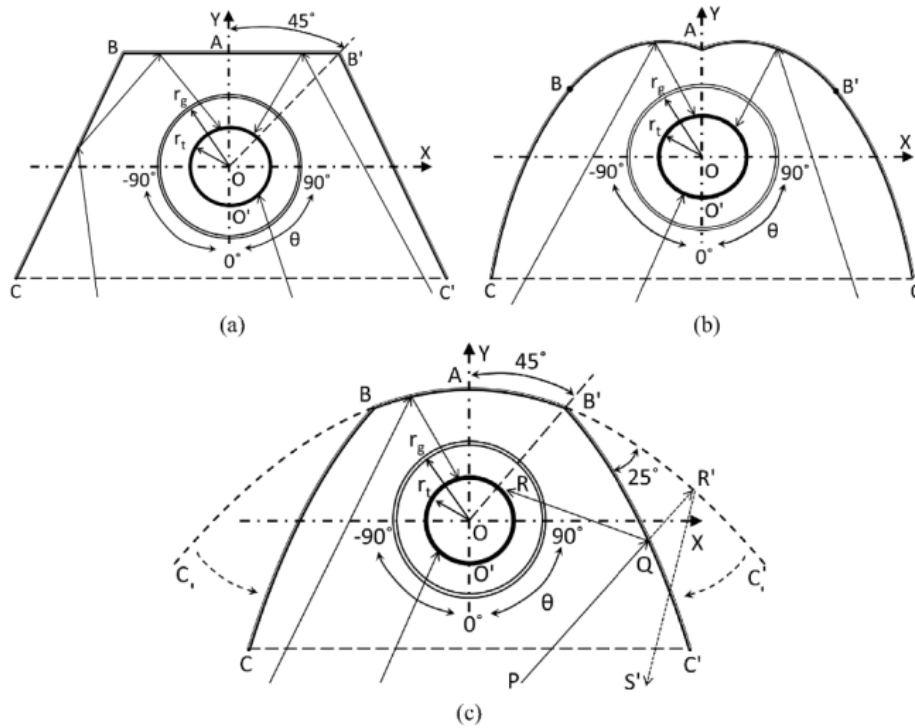

Figure 15. Different profiles of secondary concentrator (a) Trapezoidal Concentrator (b) Compound parabolic concentrator and (c) Segmented Parabolic secondary Concentrator [42]

Hack et al.[41] have studied four different secondary concentrator designs for LFC [41] : an adaptive design which takes to care for the collector optical errors to design the secondary receiver; the Compound parabolic concentrator (CPC) design, the trapezoidal design and the butterfly design. They conclude that adaptive design presents the best performance among all four designs. The CPC, the trapezoid and the butterfly, have the second, third and fourth place the respectively.

Beltagy [11] studied the effect of the use of two absorber tubes on the optical performance of LFC. He concludes that it is possible to increase the annual gain in optical efficiency estimated from 40.49 to 46.79% using two receivers instead of one Figure 156.

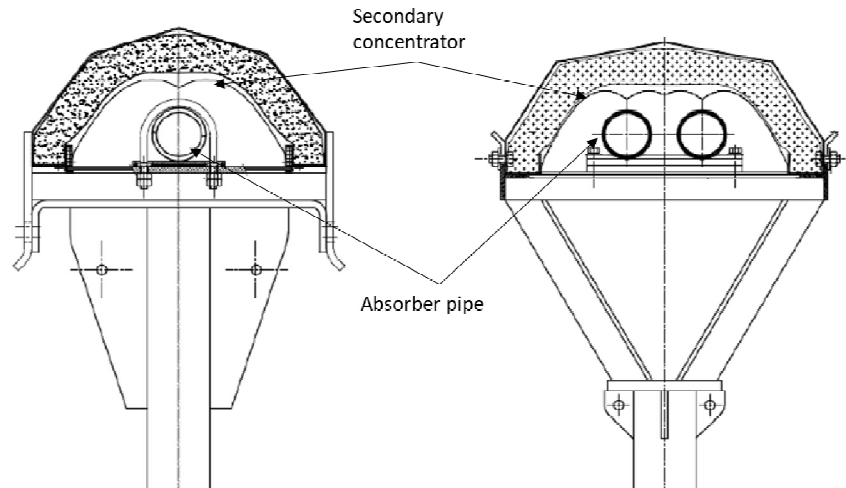

Figure 156. using of two absorbers two instead of one with a CPC secondary concentrator [11].

## ii. Receivers with multi-tube absorbers

The absorber is a kind of heat exchanger and it behaves as such. However, the total width of absorber is the same with one or multi-tube absorber its surface isn't the same it is greater. The increase of the exchange surface in a heat exchanger allows to increase its efficiency, so receiver with a multi-tubes absorbers have a better efficiency than the same receiver with one absorber. Absorber tube can be in copper, stainless steel, aluminium at placed under vacuum [7] or without any vacuum [14,24,45,52,53]. Tubes have the length of the concentrator and are put in a parallel direction with space between each one because they can dilate due to high temperature [16,21]. The diameter, number, thickness and position of tube have been studied by Dey CJ [52] the choice taking into account the pressure of the receiver, the materials used to make tubes, and the total width of absorber required. Most of the time heat transfer fluid went in a parallel direction in each tube, but sometimes edge tubes can be used to preheat heat transfer fluid by putting tubes in serial [54]. Receivers are named according to their secondary concentrator shape or their arrangement; there are: trapezoidal receiver, V-shape receiver or

triangular receiver. That kind of secondary concentrator does not allow to distribute the flux on the top of absorber [33]; it allows to refocus the missed sun beam on concentrator [55].

d. Secondary concentrator with trapezoidal shape

Multi-tube absorbers with trapezoidal secondary concentrator have been the subject of many research [14,16–19,21,24,28,53,56–58]. Receivers have been modelled and some have been experimented [26,53]. The overall heat losses varied from  $7.2 \text{ W/m}^2$  at  $150 \text{ }^\circ\text{C}$  without selective coating to  $5 \text{ W/m}$  with a selective coating. Experimental and theoretic results allow to give a standard for secondary concentrator design. Five elements must be carefully chosen for a trapezoidal secondary concentrator: the large base  $B$ , the small base  $b$ , the height  $H$ , the angle  $\theta$  and the lodge Figure 165.  $H$ ,  $B$ ,  $\theta$ , lodge can be varied in order to increase efficiency of the receiver; they are related; the variation of  $H$  involves a variation of  $\theta$  and lodge, likewise variation of  $B$  means variation of  $\theta$  and lodge. The small base  $b$  value is fixed by the absorber width.

As to reduce convective heat losses near the absorber air must be at rest so the lodge area must be very small [21,26]. Concerning  $\theta$  the authors have different about it optimal values. According to Moghimi et al. [59], the value of  $\theta$  must be  $< 30^\circ$ ,  $34^\circ$  for Singh et al. [14]. However Natarajan et al. [17], think that  $\theta$  value must be  $25^\circ < \theta < 85^\circ$ . Façao et al.[28] give other point of view; they have said that the value of  $\theta$  must be the complementary to angular between the receiver and the edge mirror. Nevertheless, all that considerations are not false. in fact, as to fluctuate the value of  $\theta$  Natarajan et al.[17] change the value of  $B$ ; so for  $\theta = 25^\circ$   $B$  is approximatively twice big then for  $\theta = 85^\circ$  with augmentation of the lodge area as consequences. According to Moghimi et al.[59] observation's  $\theta$  fluctuate with variation of  $B$  and  $H$  values and  $30^\circ$  allows to reduce lodge area. The observation of Façao et al. [28] that taking into account the principal concentrator can also be applied.

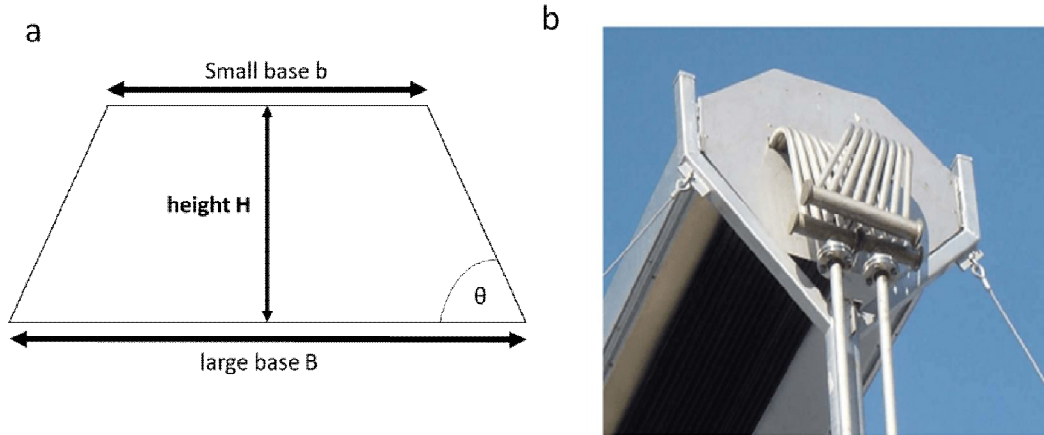
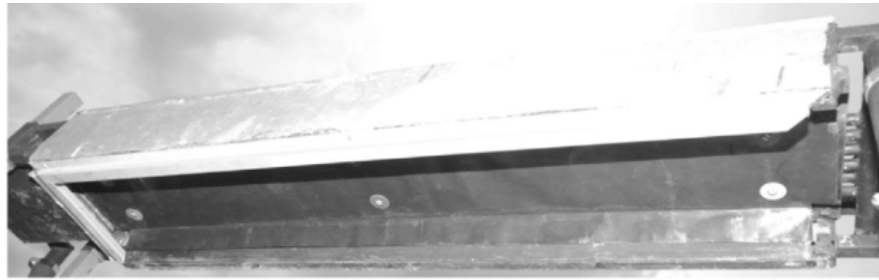

Figure 167: a-cavity overview et b-trapezoidal receiver of Areva Solar.

There are two options for trapezoidal receivers with multi-tube absorber: in the first option the absorber tubes receive directly concentrated sun beam [14,18,21,21,24,45], according to the second option absorber tubes received heat by conduction from metallic plate that receives a firstly concentrated sun beam sometimes this plate is the small base  $b$  [18,52,53].

The thickness of the metal plate is very important; the contact between tubes and plate is also important. They can be weld together, machine-made or tubes can just be put on the plate. The plate must allow a better heat reparation and make easy the use of a selective coating. Manikumar et al. [17] investigate the performance of two trapezoidal multi-tube receivers with plate surface and without plate surface Figure 176 and Figure7. They concluded that the used of the plate allow to reduce heat losses of the receiver.



(a)

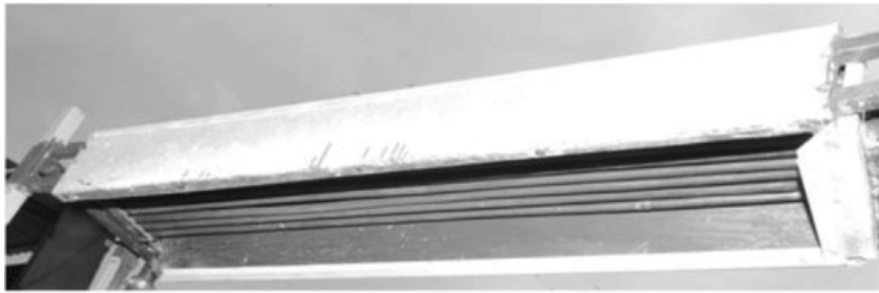

(b)

Figure 178. Trapezoidal cavity absorber (a) with plate (b) without plate [18].

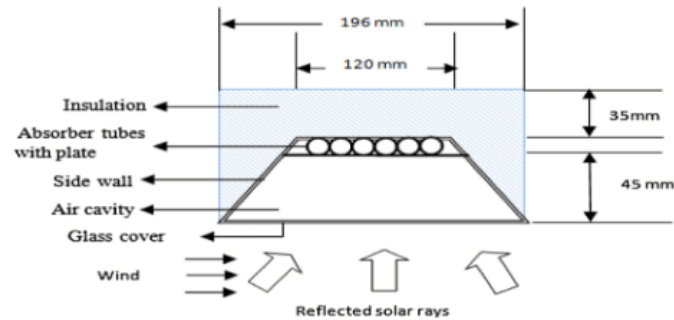

(a)

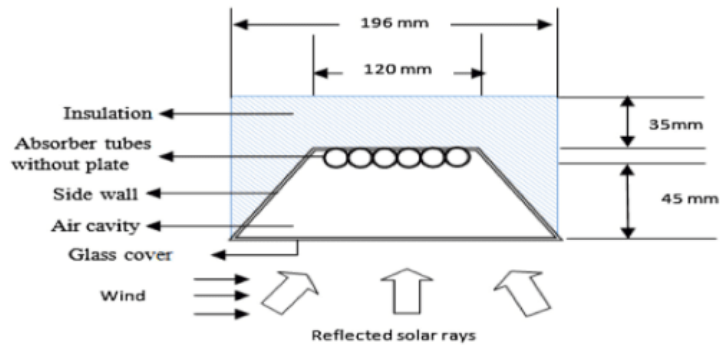

(b)

Figure 19. Sketch of trapezoidal cavity absorber (a) with plate (b) without plate [18].

e. Secondary concentrator with V shape

Tubes can be welded to give a V shape or triangular shape [60]. The design on each side of the triangle is like for secondary concentrator with two parabolic wings[33]. That receiver does not have a secondary concentrator.

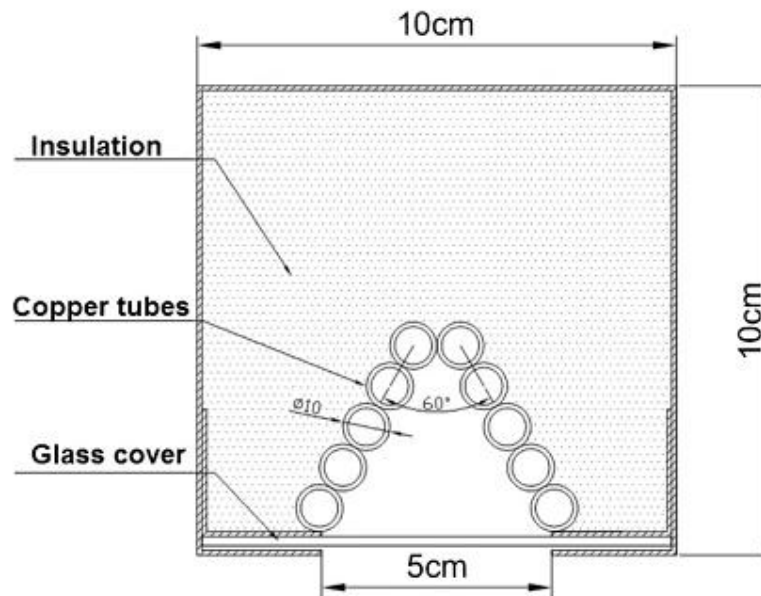

Figure 180: Reverse V-shape or triangular receiver [60].

f. Vacuum absorber

Dewar tubes are vacuum multi-tube absorber they are designed to be used as solar collectors without concentration, but they can be used as a receiver for CSP. Mills and Morrison [7,61] are they first who decide to use Dewar tubes as Fresnel receiver. Dewar tubes are sold with standard dimensions; they can be put together in series or parallel to achieve the desired receiver. Dewar tubes can be horizontal or vertical, but for each orientation secondary concentrator has a particular shape that is adapted to orientation.

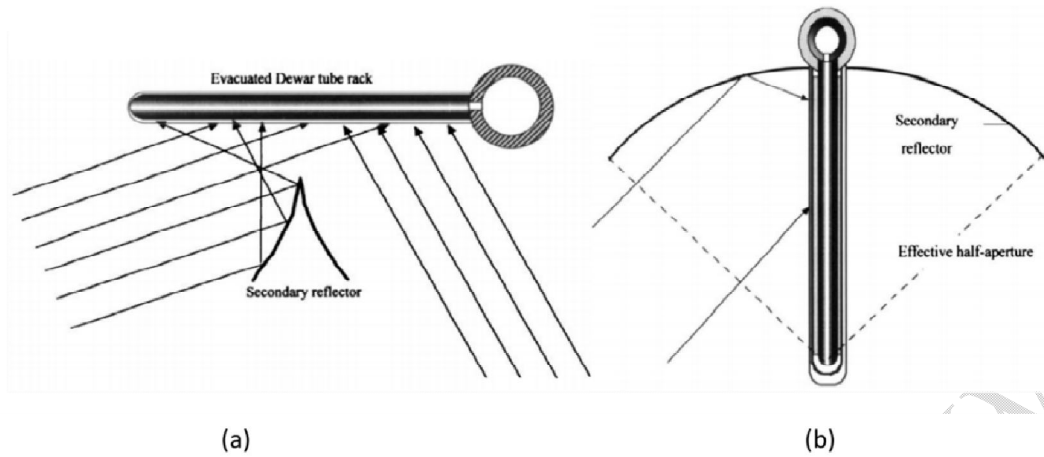

Figure 191: Dewar tubes receiver: a) horizontal orientation; b) vertical orientation [7].

### iii. Receivers with plan absorbers

Plan absorber has a rectangular parallelepiped shape [14,24,29,30,62,63]. Most of the time the inside of the parallelepiped is empty, but some researchers design a plane absorber with inside texturing in order to increase thermal exchange between absorber and heat transfer fluid. Texturing can be made with tube Figure 21. Two identical receivers, one with multi-tube absorber the other with plan absorber Figure 222 have been experienced by Singh et al. [14]. They have shown that multi-tube absorbers are 8% more efficient than plan one; in fact, multi-tube absorber have more exchange surface.

Different orientation, vertical and horizontal, of a plan absorber has been designed by Mathur et al. [29,30] using two different methods: one of the methods consisted of using mirrors of varied width because the concentrator is designed for the receiver; the second method used mirror of equal width that meaning that the receiver must be adapted to the concentrator. Vertical orientation allows to reduce shading losses due to the receiver and give a better distribution of concentrated sun beam on two faces of the absorber. In horizontal orientation the illuminated face is one that meets mirrors. With a vertical absorber when mirrors must be

adapted to the receiver their width increases with the distance to the receiver Figure 200 a). On the contrary, for horizontal absorber mirrors width decreases with the distance to the receiver Figure 200 b). Two opposite phenomena can explain that: in regard to vertical absorber, the more the mirrors are close to the receiver the more reflective image is a spread one. Therefore, the nearest mirrors must be small to avoid losses by spreading. In the horizontal position the most distant mirrors from the receiver have a spreading reflected image so they must be narrow to avoid losses by spreading.

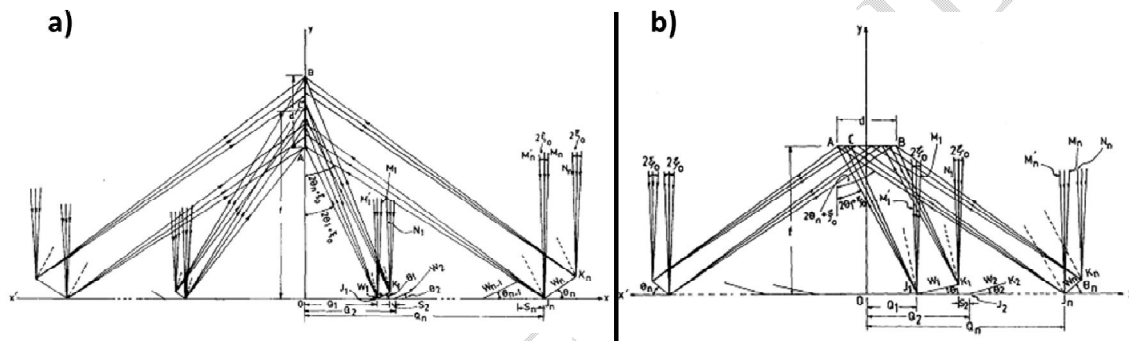

Figure 202: plan absorber a) vertical [30] and b) horizontal [29].

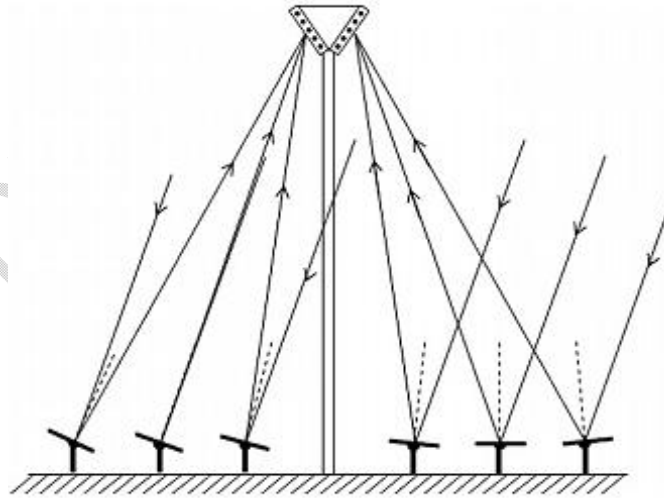

Figure 213: Texturing V-shape absorber [20].

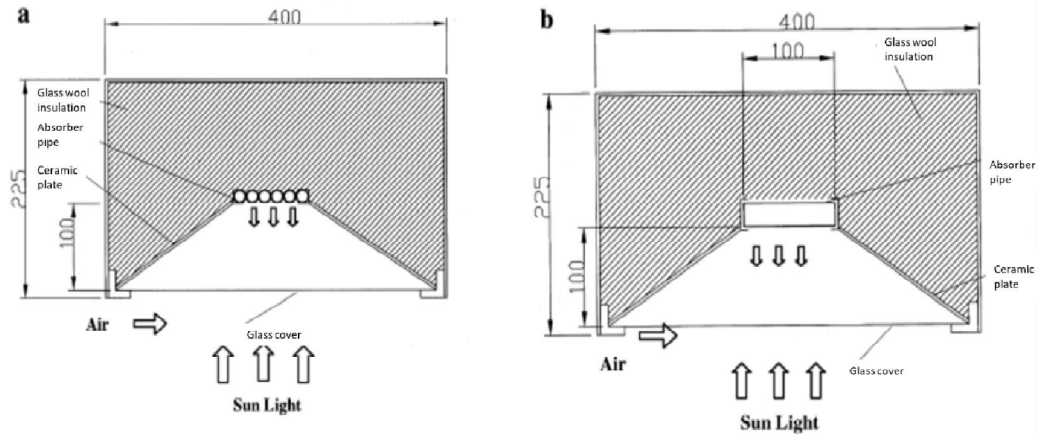

Figure 224: Two identical receivers one with multi-tube absorber the other with plan absorber [14].

Hack et al. [41] have done a comparison study between an adaptive design of secondary concentrator design by Zhu [64] and conventional design of secondary concentrator : CPC, trapezoidal and butterfly. They concluded that, for a mono-tube absorber, the adaptive design of secondary concentrator has better optical performance following by CPC, trapezoidal and the butterfly, respectively. However, for multi-tube absorbers, trapezoidal secondary concentrator has good results.

### III. Materials used in the construction of receivers

#### i. Selective coating for absorbers

One of the important steps in the design of the receiver is the choice of materials to be used for all the elements with particular attention to the absorber. Indeed, to be effective, the absorber must have certain properties which depend on the materials used. The liner material used for the absorber should:

- ✓ ideally absorb all incident radiation. It must tend towards the absorptivity of the black body in the solar spectrum [65] ;

- ✓ have a low emissivity in the infrared;
- ✓ have a very good thermal conductivity;
- ✓ be resistant to chemical attack from the heat transfer fluid used; this fluid can be water, corrosive oil or molten salt;
- ✓ resist attacks from the surrounding environment;
- ✓ be low cost, easy to handle and have a long lifespan.

It is very rare that a single material combines all these properties. Most often, we used to use a combination of different materials, each providing one or more of the required properties. The substrates most often used are copper [66,67], aluminium [68], stainless steel [69], ceramics [66,67] and mild steel [52]. These materials are chosen for their good thermal conductivity, low infrared emissivity, low cost and corrosion resistance. The basic solar receivers are made from the materials mentioned above and then covered with a matte black paint. This matte black paint increases the absorptivity of the absorber. The most efficient absorbers are covered with a selective coating.

Selective coatings impart two essential optical properties: high absorptivity (>92%) in the solar spectrum and low emissivity (<15%) in the far infrared. Many researchers have experimentally compared conventional absorbers painted black with the same absorbers coated with a selective coating. They concluded that the selective coating reduced the radiative losses observed at the receiver by 20-30% [24,39,62]. There are several mechanisms for obtaining selective coatings. These mechanisms can be grouped into different large families depending on the materials and the principle used [65–67,70–72,74]: intrinsic or “mass absorbers [62,65–67,70,71,74], Semiconductor-metal tandems [65–67,71], Multilayer absorbers [65–67,71,72], Surface texturing [65,66,71,75,76], Metal-dielectric composite coating or cermets [65,66,69,71,77].

Selective coatings can be directly spread on the substrate, or the top layers of the substrate can be made into a selective coating [72]. Spreading can be done by painting, by Anodization, by a vacuum sputtering, by pyrolytically depositing, by electrolysis, by chemical or Physical vacuum deposition or by sol-gel coating [69]. Metal is transformed into a textured surface by a chemical reaction.

The absorbant black paints are the least expensive and easiest to apply selective coatings. They make it possible to obtain a fairly good selectivity  $\alpha = 0.83 - 0.96$  and  $\epsilon = 0.13 - 0.3$  provided that they are applied to the appropriate substrate: polished copper, polished aluminum, stainless steel [71]. Cermets can be used as a pigment for selective paints. The major drawback is that the cermets cannot be exposed to the ambient environment; they must be protected by a glass envelope or sometimes be under vacuum [33]. The most used materials for the absorbers of LFC receivers are copper and steel coated with a high absorptivity paint. The most marketed products are Solkote [78], MAXORB foil [39], Pyromark [79,80], Cobalt [80].

## ii. Glass used for greenhouse effect

Using a suitable material, an absorber can absorb and transfer a maximum heat to HTF, but it is necessary to keep that heat. Glass due to its selective property is also an excellent candidate for reducing radiative losses. In fact, glass is transparent at low wavelengths of solar radiation  $< 2.5 \mu\text{m}$  and is almost opaque at high wavelengths such as those of the far infrared; that is calls greenhouse effect. The heated absorber emits far infrared radiation. By enclosing the absorber in a glass-covered enclosure, radiative losses are reduced [11,81–85]. In addition, the use of glass makes it possible to create a closed environment which also makes it possible to

limit convective losses. The vacuum is used to insulate the absorber face looking at mirrors; which reduces convection losses. The most used glass cover is borosilicate [11,36,52,56].

#### IV. Technical analysis

The receivers in the LFCs are basically composed of an absorber and a protective envelope. To the above elements, can be added: a secondary concentrator and a thermal insulation. There is a wide variety of receivers that can be distinguished by the shape of the absorber: mono-tube, multi-tube, plane. The shape of the secondary concentrator or its absence allows to categorize the receivers. The secondary concentrator can be: butterfly, CPC, segmented parabolic secondary concentrator or trapezoidal. Vacuum mono-tube receivers have heat losses between 200 W/m and 270 W/m for an absorber temperature of 350 °C [86]. They have the best thermal efficiency. However, without a secondary concentrator there is an optical loss. There are different types of secondary concentrators that can fit a vacuum mono tube: butterfly secondary concentrator, CPC secondary concentrator and trapezoidal secondary concentrator. However, vacuum absorbers are very expensive and there are no local manufacturers in the sub-Saharan African regions. The vacuum mono-tube can be replaced by mono-tube under partial vacuum. The partial vacuum can be provided with a glass envelope or a glass cover, but they must have a secondary concentrator. A mono tube receiver at partial vacuum loses more than 350 W/m at 350 °C [86]. Since an absorber is a heat exchanger, it is possible to improve the heat transfer by increasing the exchange surface and in this case instead of having one tube more than two tubes can be used: multi-tube receivers. The multi-tube receivers are under partial vacuum with a trapezoidal secondary receiver. Receivers at the partial vacuum are cheaper, easy to manufacture and to handle by hand because even when there is breakage there is no vacuum loss. They can be made of copper or stainless steel, which are available in sub-Saharan Africa. In order to increase the absorptivity of the receiver

by 20 to 30% it should be coated with a high absorptivity paint. The lowest heat losses of a multi-tube receiver with a trapezoidal secondary concentrator can reach 500 W/m at an absorber temperature of 350 °C [17]. Among the secondary concentrators, the trapezoidal one is the simplest to design and the least expensive.

## V. Conclusion

A state of art of receivers for LFC are reviewed in this paper. By carrying out this review, we want to identify the most suitable type of receiver for small scale LFC suitable for rural areas of Sub-Saharan. A classification of receivers was presented according to their shapes and the type of tubes used as absorbers. The materials generally used to improve the performance of the receiver were also discussed. Despite the fact that vacuum single tube receivers have the best efficiency, they are not commercialized in Sub-Saharan African countries. In addition, their implementation may be technologically complex unlike trapezoidal receivers with a multi-tube copper absorber. For these reasons, We concluded that a trapezoidal receiver with a multi-tube absorber in copper coated with black paint and glass cover is a kind of LFC receiver that can be used in rural area of Sub-Saharan Africa.

### References:

- [1] Singh T, Hussien MAA, Al-Ansari T, Saoud K, McKay G. Critical review of solar thermal resources in GCC and application of nanofluids for development of efficient and cost effective CSP technologies. *Renew Sustain Energy Rev* 2018;91:708–19. <https://doi.org/10.1016/j.rser.2018.03.050>.
- [2] Seshie YM, N'Tsoukpoe KE, Neveu P, Coulibaly Y, Azoumah YK. Small scale concentrating solar plants for rural electrification. *Renew Sustain Energy Rev* 2018;90:195–209. <https://doi.org/10.1016/j.rser.2018.03.036>.
- [3] European Academies Science Advisory Council. Concentrating solar power: its potential contribution to a sustainable energy future. Halle (Saale): EASAC Secretariat; 2011.
- [4] IEA-ETSAP and IRENA. Concentrating Solar Power Technology Brief. 2013.
- [5] Concentrating Solar Power Projects by Technology | Concentrating Solar Power Projects | NREL n.d. <https://solarpaces.nrel.gov/by-technology> (accessed December 3, 2022).

- [6] Linear Concentrator System Concentrating Solar-Thermal Power Basics. EnergyGov n.d. <https://www.energy.gov/eere/solar/linear-concentrator-system-concentrating-solar-thermal-power-basics> (accessed December 14, 2022).
- [7] Mills DR, Morrison GL. Compact Linear Fresnel Reflector solar thermal powerplants. *Sol Energy* 2000;68:263–83. [https://doi.org/10.1016/S0038-092X\(99\)00068-7](https://doi.org/10.1016/S0038-092X(99)00068-7).
- [8] Zhu G, Wendelin T, Wagner MJ, Kutscher C. History, current state, and future of linear Fresnel concentrating solar collectors. *Sol Energy* 2014;103:639–52. <https://doi.org/10.1016/j.solener.2013.05.021>.
- [9] Chaves J, Collares-Pereira M. Etendue-matched two-stage concentrators with multiple receivers. *Sol Energy* 2010;84:196–207. <https://doi.org/10.1016/j.solener.2009.10.022>.
- [10] Zhu J, Chen Z. Optical design of compact linear fresnel reflector systems. *Sol Energy Mater Sol Cells* 2018;176:239–50. <https://doi.org/10.1016/j.solmat.2017.12.016>.
- [11] Beltagy H. The effect of glass on the receiver and the use of two absorber tubes on optical performance of linear fresnel solar concentrators. *Energy* 2021;224:120111. <https://doi.org/10.1016/j.energy.2021.120111>.
- [12] Duffie JA, Beckman WA. *Solar engineering of thermal processes*. Hoboken: Wiley; 2013.
- [13] Silvi C. The pioneering work on linear Fresnel reflector concentrators (LFCs) in Italy. *Proc SolarPACES* 2009.
- [14] Singh PL, Sarviya RM, Bhagoria JL. Thermal performance of linear Fresnel reflecting solar concentrator with trapezoidal cavity absorbers. *Appl Energy* 2010;87:541–50. <https://doi.org/10.1016/j.apenergy.2009.08.019>.
- [15] Choudhury C, Sehgal HK. A fresnel strip reflector-concentrator for tubular solar-energy collectors. *Appl Energy* 1986;23:143–54. [https://doi.org/10.1016/0306-2619\(86\)90036-X](https://doi.org/10.1016/0306-2619(86)90036-X).
- [16] Facão J, Oliveira AC. Numerical simulation of a trapezoidal cavity receiver for a linear Fresnel solar collector concentrator. *Renew Energy* 2011;36:90–6. <https://doi.org/10.1016/j.renene.2010.06.003>.
- [17] Natarajan SK, Reddy KS, Mallick TK. Heat loss characteristics of trapezoidal cavity receiver for solar linear concentrating system. *Appl Energy* 2012;93:523–31. <https://doi.org/10.1016/j.apenergy.2011.12.011>.
- [18] Manikumar R, Valan Arasu A. Heat loss characteristics study of a trapezoidal cavity absorber with and without plate for a linear Fresnel reflector solar concentrator system. *Renew Energy* 2014;63:98–108. <https://doi.org/10.1016/j.renene.2013.09.005>.
- [19] Flores Larsen S, Altamirano M, Hernández A. Heat loss of a trapezoidal cavity absorber for a linear Fresnel reflecting solar concentrator. *Renew Energy* 2012;39:198–206. <https://doi.org/10.1016/j.renene.2011.08.003>.
- [20] Abbas R, Montes MJ, Piera M, Martínez-Val JM. Solar radiation concentration features in Linear Fresnel Reflector arrays. *Energy Convers Manag* 2012;54:133–44. <https://doi.org/10.1016/j.enconman.2011.10.010>.
- [21] Sahoo SS, Singh S, Banerjee R. Analysis of heat losses from a trapezoidal cavity used for Linear Fresnel Reflector system. *Sol Energy* 2012;86:1313–22. <https://doi.org/10.1016/j.solener.2012.01.023>.

- [22] Pauletta S. A Solar Fresnel Collector Based on an Evacuated Flat Receiver. *Energy Procedia* 2016;101:480–7. <https://doi.org/10.1016/j.egypro.2016.11.061>.
- [23] Taramona S, González-Gómez PÁ, Briongos JV, Gómez-Hernández J. Designing a flat beam-down linear Fresnel reflector. *Renew Energy* 2022;187:484–99. <https://doi.org/10.1016/j.renene.2022.01.104>.
- [24] Singh PL, Sarviya RM, Bhagoria JL. Heat loss study of trapezoidal cavity absorbers for linear solar concentrating collector. *Energy Convers Manag* 2010;51:329–37. <https://doi.org/10.1016/j.enconman.2009.09.029>.
- [25] Rabl A. Comparison of solar concentrators. *Sol Energy* 1976;18:93–111. [https://doi.org/10.1016/0038-092X\(76\)90043-8](https://doi.org/10.1016/0038-092X(76)90043-8).
- [26] Sahoo SS, Varghese SM, Suresh Kumar C, Viswanathan SP, Singh S, Banerjee R. Experimental investigation and computational validation of heat losses from the cavity receiver used in linear Fresnel reflector solar thermal system. *Renew Energy* 2013;55:18–23. <https://doi.org/10.1016/j.renene.2012.11.036>.
- [27] Gordon JM, Ries H. Tailored edge-ray concentrators as ideal second stages for Fresnel reflectors. *Appl Opt* 1993;32:2243–51.
- [28] Facao J, Oliveira AC. Simulation of a linear Fresnel solar collector concentrator. *Int J Low-Carbon Technol* 2010;5:125–9. <https://doi.org/10.1093/ijlct/ctq011>.
- [29] Mathur SS, Negi BS, Kandpal TC. Geometrical designs and performance analysis of a linear Fresnel reflector solar concentrator with a flat horizontal absorber. *Int J Energy Res* 1990;14:107–24.
- [30] Negi BS, Kandpal TC, Mathur SS. Designs and performance characteristics of a linear fresnel reflector solar concentrator with a flat vertical absorber. *Sol Wind Technol* 1990;7:379–92. [https://doi.org/10.1016/0741-983X\(90\)90023-U](https://doi.org/10.1016/0741-983X(90)90023-U).
- [31] Mathur SS, Kandpal TC, Negi BS. Optical design and concentration characteristics of linear Fresnel reflector solar concentrators—II. Mirror elements of equal width. *Energy Convers Manag* 1991;31:221–32. [https://doi.org/10.1016/0196-8904\(91\)90076-U](https://doi.org/10.1016/0196-8904(91)90076-U).
- [32] Mathur SS, Kandpal TC, Negi BS. Optical design and concentration characteristics of linear Fresnel reflector solar concentrators—I. Mirror elements of varying width. *Energy Convers Manag* 1991;31:205–19. [https://doi.org/10.1016/0196-8904\(91\)90075-T](https://doi.org/10.1016/0196-8904(91)90075-T).
- [33] Grena R, Tarquini P. Solar linear Fresnel collector using molten nitrates as heat transfer fluid. *Energy* 2011;36:1048–56. <https://doi.org/10.1016/j.energy.2010.12.003>.
- [34] Qiu Z, Li Q, Zhang Y, Jia H. Optical Design of Linear Fresnel Reflector Solar Concentrators. *Energy Procedia* 2012;14:1960–6. <https://doi.org/10.1016/j.egypro.2011.12.1194>.
- [35] Veynandt F. Cogénération héliothermodynamique avec concentrateur linéaire de Fresnel : modélisation de l'ensemble du procédé 2011. <http://thesis.inp-toulouse.fr/archive/00001786/> (accessed September 30, 2014).
- [36] Schott Ptr70 4th Generation Brochure | PDF | Solar Energy | Power Station. Scribd n.d. <https://www.scribd.com/document/364034326/Schott-Ptr70-4th-Generation-Brochure> (accessed December 5, 2022).
- [37] Fernández-García A, Cantos-Soto ME, Röger M, Wieckert C, Hutter C, Martínez-Arcos L. Durability of solar reflector materials for secondary concentrators used in CSP

- systems. *Sol Energy Mater Sol Cells* 2014;130:51–63. <https://doi.org/10.1016/j.solmat.2014.06.043>.
- [38] Cheng Z-D, He Y-L, Qiu Y. A detailed nonuniform thermal model of a parabolic trough solar receiver with two halves and two inactive ends. *Renew Energy* 2014;74:139–47. <https://doi.org/10.1016/j.renene.2014.07.060>.
- [39] Negi BS, Mathur SS, Kandpal TC. Optical and thermal performance evaluation of a linear fresnel reflector solar concentrator. *Sol Wind Technol* 1989;6:589–93. [https://doi.org/10.1016/0741-983X\(89\)90095-7](https://doi.org/10.1016/0741-983X(89)90095-7).
- [40] Zhu Y, Shi J, Li Y, Wang L, Huang Q, Xu G. Design and thermal performances of a scalable linear Fresnel reflector solar system. *Energy Convers Manag* 2017;146:174–81. <https://doi.org/10.1016/j.enconman.2017.05.031>.
- [41] Hack M, Zhu G, Wendelin T. Evaluation and comparison of an adaptive method technique for improved performance of linear Fresnel secondary designs. *Appl Energy* 2017;208:1441–51. <https://doi.org/10.1016/j.apenergy.2017.09.009>.
- [42] Chaitanya Prasad GS, Reddy KS, Sundararajan T. Optimization of solar linear Fresnel reflector system with secondary concentrator for uniform flux distribution over absorber tube. *Sol Energy* 2017;150:1–12. <https://doi.org/10.1016/j.solener.2017.04.026>.
- [43] Famiglietti A, Lecuona A. Direct solar air heating inside small-scale linear Fresnel collector assisted by a turbocharger: Experimental characterization. *Appl Therm Eng* 2021;196:117323. <https://doi.org/10.1016/j.applthermaleng.2021.117323>.
- [44] Canavarro D, Chaves J, Collares-Pereira M. New second-stage concentrators (XX SMS) for parabolic primaries; Comparison with conventional parabolic trough concentrators. *Sol Energy* 2013;92:98–105. <https://doi.org/10.1016/j.solener.2013.02.011>.
- [45] Singh PL, Ganesan S, Yàdav GC. Technical note: Performance study of a linear Fresnel concentrating solar device. *Renew Energy* 1999;18:409–16. [https://doi.org/10.1016/S0960-1481\(98\)00805-2](https://doi.org/10.1016/S0960-1481(98)00805-2).
- [46] Llamas D. Puerto Errado 2: World’s largest CSP based on Linear-Fresnel technology. HELIOSCSP n.d. <https://helioscsp.com/puerto-errado-2-worlds-largest-csp-based-on-linear-fresnel-technology/> (accessed December 6, 2022).
- [47] Montanet E, Rodat S, Falcoz Q, Roget F. Influence de la topographie sur les performances optiques de concentrateurs linéaires de Fresnel : le cas de la centrale solaire eLLO 2022.
- [48] SUNCNIM et la Banque des Territoires inaugurent la centrale solaire thermodynamique avec stockage d’énergie de Llo | Suncnim n.d. <https://www.suncnim.com/en/suncnim-et-la-banque-des-territoires-inaugurent-la-centrale-solaire-thermodynamique-avec-stockage> (accessed December 1, 2022).
- [49] Hofer A, Cuevas F, Heimsath A, Nitz P, Platzer WJ, Scholl S. Extended Heat Loss and Temperature Analysis of Three Linear Fresnel Receiver Designs. *Energy Procedia* 2015;69:424–33. <https://doi.org/10.1016/j.egypro.2015.03.049>.
- [50] Heimsath A, Cuevas F, Hofer A, Nitz P, Platzer WJ. Linear Fresnel Collector Receiver: Heat Loss and Temperatures. *Energy Procedia* 2014;49:386–97. <https://doi.org/10.1016/j.egypro.2014.03.042>.
- [51] Montes MJ, Abbas R, Muñoz M, Muñoz-Antón J, Martínez-Val JM. Advances in the linear Fresnel single-tube receivers: Hybrid loops with non-evacuated and evacuated

- receivers. *Energy Convers Manag* 2017;149:318–33. <https://doi.org/10.1016/j.enconman.2017.07.031>.
- [52] Dey CJ. Heat transfer aspects of an elevated linear absorber. *Sol Energy* 2004;76:243–9. <https://doi.org/10.1016/j.solener.2003.08.030>.
- [53] Reynolds DJ, Jance MJ, Behnia M, Morrison GL. An experimental and computational study of the heat loss characteristics of a trapezoidal cavity absorber. *Sol Energy* 2004;76:229–34. <https://doi.org/10.1016/j.solener.2003.01.001>.
- [54] Abbas R, Muñoz J, Martínez-Val JM. Steady-state thermal analysis of an innovative receiver for linear Fresnel reflectors. *Appl Energy* 2012;92:503–15. <https://doi.org/10.1016/j.apenergy.2011.11.070>.
- [55] Abbas R, Muñoz-Antón J, Valdés M, Martínez-Val JM. High concentration linear Fresnel reflectors. *Energy Convers Manag* 2013;72:60–8. <https://doi.org/10.1016/j.enconman.2013.01.039>.
- [56] Reddy KS, Kumar KR. Estimation of convective and radiative heat losses from an inverted trapezoidal cavity receiver of solar linear Fresnel reflector system. *Int J Therm Sci* 2014;80:48–57. <https://doi.org/10.1016/j.ijthermalsci.2014.01.022>.
- [57] Pye JD, Morrison GL, Behnia M, Mills DR. Modelling of Cavity Receiver Heat Transfer for the Compact Linear Fresnel Reflector 2003.
- [58] Ordóñez F, Flores E, Soria R. Comprehensive analysis of the variables influencing the techno-economic optimization of medium temperature linear Fresnel collectors. *Energy Rep* 2021;7:5747–61. <https://doi.org/10.1016/j.egyr.2021.08.194>.
- [59] Moghimi MA, Craig KJ, Meyer JP. Optimization of a trapezoidal cavity absorber for the Linear Fresnel Reflector. *Sol Energy* 2015;119:343–61. <https://doi.org/10.1016/j.solener.2015.07.009>.
- [60] Lin M, Sumathy K, Dai YJ, Wang RZ, Chen Y. Experimental and theoretical analysis on a linear Fresnel reflector solar collector prototype with V-shaped cavity receiver. *Appl Therm Eng* 2013;51:963–72. <https://doi.org/10.1016/j.applthermaleng.2012.10.050>.
- [61] Morrison GL, Mills DR, Corporatio S. Solar Thermal Power Systems–Stanwell Power Station Project”. *Proc. ANZSES Annu. Conf.*, 1999.
- [62] Khan MdKA. Technical note Copper oxide coatings for use in a linear solar Fresnel reflecting concentrating collector. *Renew Energy* 1999;17:603–8. [https://doi.org/10.1016/S0960-1481\(98\)00023-8](https://doi.org/10.1016/S0960-1481(98)00023-8).
- [63] Capeillère J, Toutant A, Olalde G, Boubault A. Thermomechanical behavior of a plate ceramic solar receiver irradiated by concentrated sunlight. *Sol Energy* 2014;110:174–87. <https://doi.org/10.1016/j.solener.2014.08.039>.
- [64] Zhu G. New adaptive method to optimize the secondary reflector of linear Fresnel collectors. *Sol Energy* 2017;144:117–26. <https://doi.org/10.1016/j.solener.2017.01.005>.
- [65] Platzer W, Hildebrandt C. 15 - Absorber materials for solar thermal receivers in concentrating solar power (CSP) systems. In: Lovegrove K, Stein W, editors. *Conc. Sol. Power Technol.*, Woodhead Publishing; 2012, p. 469–94.
- [66] Atkinson C, Sansom CL, Almond HJ, Shaw CP. Coatings for concentrating solar systems – A review. *Renew Sustain Energy Rev* 2015;45:113–22. <https://doi.org/10.1016/j.rser.2015.01.015>.

- [67] Lampert CM. Coatings for enhanced photothermal energy collection I. Selective absorbers. *Sol Energy Mater* 1979;1:319–41. [https://doi.org/10.1016/0165-1633\(79\)90001-7](https://doi.org/10.1016/0165-1633(79)90001-7).
- [68] Konttinen P, Lund PD, Kilpi RJ. Mechanically manufactured selective solar absorber surfaces. *Sol Energy Mater Sol Cells* 2003;79:273–83. [https://doi.org/10.1016/S0927-0248\(02\)00411-7](https://doi.org/10.1016/S0927-0248(02)00411-7).
- [69] Joly M, Antonetti Y, Python M, Lazo MAG, Gascou T, Hessler-Wyser A, et al. Selective Solar Absorber Coatings on Receiver Tubes for CSP – Energy-efficient Production Process by Sol-gel dip-coating and Subsequent Induction Heating. *Energy Procedia* 2014;57:487–96. <https://doi.org/10.1016/j.egypro.2014.10.202>.
- [70] Hutchins MG. Spectrally selective solar absorber coatings. *Appl Energy* 1979;5:251–62. [https://doi.org/10.1016/0306-2619\(79\)90016-3](https://doi.org/10.1016/0306-2619(79)90016-3).
- [71] Kennedy CE. Review of mid-to high-temperature solar selective absorber materials. vol. 1617. National Renewable Energy Laboratory Golden Colorado; 2002.
- [72] Petitjean JP, Vander Poorten H. Les revêtements sélectifs et leur rôle dans l'amélioration des performances des collecteurs solaires. *Surf Technol* 1980;11:229–58.
- [73] Zhao S, Uppsala universitet, Teknisk-naturvetenskapliga fakulteten. Spectrally selective solar absorbing coatings prepared by dc magnetron sputtering. *Acta Universitatis Upsaliensis*, 2007.
- [74] Shimizu M, Suzuki M, Iguchi F, Yugami H. High-temperature Solar Selective Absorbers Using Transparent Conductive Oxide Coated Metal. *Energy Procedia* 2014;57:418–26. <https://doi.org/10.1016/j.egypro.2014.10.195>.
- [75] Harding GL, Lake MR. Sputter etched metal solar selective absorbing surfaces for high temperature thermal collectors. *Sol Energy Mater* 1981;5:445–64. [https://doi.org/10.1016/0165-1633\(81\)90079-4](https://doi.org/10.1016/0165-1633(81)90079-4).
- [76] Cuomo JJ, Ziegler JF, Woodall JM. A new concept for solar energy thermal conversion. *Appl Phys Lett* 1975;26:557–9. <https://doi.org/10.1063/1.87990>.
- [77] Farooq M, Green AA, Hutchins MG. High performance sputtered Ni: SiO<sub>2</sub> composite solar absorber surfaces. *Sol Energy Mater Sol Cells* 1998;54:67–73. [https://doi.org/10.1016/S0927-0248\(97\)00265-1](https://doi.org/10.1016/S0927-0248(97)00265-1).
- [78] Andemeskel A, Suriwong T, Wamae W. Effects of Aluminum Fin Thickness Coated with a Solar Paint on the Thermal Performance of Evacuated Tube Collector. *Energy Procedia* 2017;138:429–34. <https://doi.org/10.1016/j.egypro.2017.10.193>.
- [79] Ho CK, Pacheco JE. Levelized Cost of Coating (LCOC) for selective absorber materials. *Sol Energy* 2014;108:315–21. <https://doi.org/10.1016/j.solener.2014.05.017>.
- [80] Boubault A, Ho CK, Hall A, Lambert TN, Ambrosini A. Durability of solar absorber coatings and their cost-effectiveness. *Sol Energy Mater Sol Cells* 2017;166:176–84. <https://doi.org/10.1016/j.solmat.2017.03.010>.
- [81] Ky TSM, Ouedraogo S, Ousmane M, Dianda B, Ouedraogo E, Bathiebo DJ. Experimental Study of a Stationary Hot Air Solar Collector Built with Hemispherical Concentrators and Enhanced with Fresnel Lenses. *Phys Sci Int J* 2021;8–22. <https://doi.org/10.9734/psij/2021/v25i130233>.

- [82] Tian Y, Zhao CY. A review of solar collectors and thermal energy storage in solar thermal applications. *Appl Energy* 2013;104:538–53. <https://doi.org/10.1016/j.apenergy.2012.11.051>.
- [83] Montes MJ, Abbas R, Barbero R, Rovira A. A new design of multi-tube receiver for Fresnel technology to increase the thermal performance. *Appl Therm Eng* 2022;204:117970. <https://doi.org/10.1016/j.applthermaleng.2021.117970>.
- [84] Montes MJ, Rubbia C, Abbas R, Martínez-Val JM. A comparative analysis of configurations of linear Fresnel collectors for concentrating solar power. *Energy* 2014;73:192–203. <https://doi.org/10.1016/j.energy.2014.06.010>.
- [85] Rungasamy AE, Craig KJ, Meyer JP. 3-D CFD Modeling of a Slanted Receiver in a Compact Linear Fresnel Plant with Etendue-Matched Mirror Field. *Energy Procedia* 2015;69:188–97. <https://doi.org/10.1016/j.egypro.2015.03.022>.
- [86] Burkholder F, Kutscher C. Heat Loss Testing of Schott's 2008 PTR70 Parabolic Trough Receiver. 2009. <https://doi.org/10.2172/1369635>.

UNDER PEER REVIEW