

EFFECTS OF THE SPEED OF ADVANCEMENT OF MECHANIZED PLOWING ON THE STRUCTURE OF THE FERRALITIC SOIL

Running ~~Title~~ Title: Speed of mechanized tillage

Formatted: English (United States)

ABSTRACT

The present work consists in evaluating the impacts of the plowing speed of three-body plows/discs hitched to a 60 HP tractor, on the structure of the ferralitic soil and determining the optimal speed in the Benin plateau, from 2019-2021. All plowing was carried out ~~in~~ on the same day on 21 plots, divided into 3 blocks of 7 elementary plots.

Formatted: English (United States)

The treatments are: V0, V1, V2, V3, V4, V5, and V6, ie 2, 4, 6, 8, 10, and 12 km/h. V0 is a witness. The tests are carried out according to the standards: NF EN ISO 17892-4:2018, for the particle size analysis, NF EN ISO 17892:2018, for the Atterberg limits, NF P 94-050:1995, for the water content by weight, NF XP P 94 -047:1998, for the rate of organic matter, NF EN 1097-3:1998, for the apparent density. Soil conductivity is determined by the Muntz method (double rings). The results show that plowing at an average speed (6 km/h) generates a better content of water and organic matter which are respectively $5.04 \pm 0.76\%$ and $0.304 \pm 0.004\%$ for the ploughshare ~~then~~ than (6.

Formatted: English (United States)

Formatted: English (United States)

$47 \pm 0.35\%$; $0.324 \pm 0.012\%$) for the disc plow. The higher content of water and organic matter generated by the average speed of 6 km/h would limit the risks of embrittlement, while guaranteeing a conservative tendency of fertility. This work will allow agricultural tractor operators to better perform ferralitic tillage operations taking into

Formatted: English (United States)

account the optimal plowing speed without seriously damaging the soil structure, a guarantee of sustainable development in agriculture.

Keywords: Tillage, Struct-studies, Agriculture, Technical, Mechanical.

1. INTRODUCTION

In Benin, agriculture plays an important role because of its interrelationships with food, wealth creation, education, health, and nutrition (NHDR, 2015). Indeed, agriculture in Benin represents more than 50% of the Gross Domestic Product (GDP), contributes 80% to the value of trade, and provides industry with more than 50% of raw materials (FAO, 2016). Thus, agricultural production systems must be intensified in order to feed the growing world population. The intensification of these systems ~~therefore, therefore,~~ involves several processes with nowadays the introduction and use of agricultural machinery or machinery in order to achieve the objectives related to the satisfaction of the needs of the world population, hence agricultural mechanization. This agricultural mechanization covers the use of tools and machines for land reclamation, production, and post-harvest techniques, using human energy, and animal or chemical internal combustion engines. It is an essential agricultural input in sub-Saharan Africa potentially capable of transforming the lives and economic conditions of millions of families in rural areas (FAO, 2019) and ~~allows allowing~~ the farmer to obtain a better income (Pussemier and Goevenset al., 2017). It is in keeping with this logic that the Ministry of Agriculture has drawn up a strategic plan to revive the agricultural sector with the aim of making Benin an agricultural power and combating food insecurity (MAEP, 2019). This plan plans to boost production through the mechanization of production factors, in particular the soil, which represents the support for plant growth. Because a well-structured soil allows abundant root growth and offers good aeration

Formatted: English (United States)

Formatted: English (United States)

Formatted: English (United States)

Formatted: English (United States)

Formatted: English (United States)

Formatted: English (United States)

Formatted: English (United States)

Formatted: Font: Not Italic

Formatted: Font: Not Italic, English (United States)

Formatted: English (United States)

(Feddal, 2011). Indeed, tillage causes erosion, compaction, compaction as well as the depletion of organic matter, and the limitation of water circulation (Köller, 2003; Lal *et al.*, 2007). It affects the biotic and abiotic factors of the soil, either directly by modifying the structural properties of the soil such as the arrangement of voids, aggregates, and the connectivity of the pores, or indirectly by changing the conditions of aeration, temperature, and penetrability of the soil. Soil through the roots (Huwe, 2003).

Formatted: English (United States)

Formatted: English (United States)

However, the farmer is often looking for an optimal soil preparation that meets the requirements of his crop. According to (Chehaibiet *al.*, 2002), tillage can be optimized by an adequate choice of the width of the plowing, and the practical forward speed. This last factor is often not taken into account when carrying out cultural operations. While according to the work of (Chehaibiet *al.*, 2008), the speed of plowing has a considerable impact on the physical parameters of the soil. Slow-speed tillage (2 km/h) provides a

better structured better-structured volume of soil with a greater worked depth leading to better yield (Chehaibiet *al.*, 2008). It has also been shown (Damien, 2017) that plowing at too high a speed (greater than 10 km/h) can lead to the positioning of debris on the top of the plow strips and therefore will penalize the deep burial of seeds Weeds. According to the (Seineet *al.*, 2013), plowing at a speed of 4-5 km/h is recommended on loamy soil in order to allow better preservation of the structure of the heart of the plowing. All this shows that the speed of plowing influences the structure of the soil.

Formatted: English (United States)

However, the choice of the optimum plowing speed to promote good soil structure, excellent germination, and good crop yield has been little studied. The overall objective

Formatted: English (United States)

of this study is to assess the impact of plowing speed on soil structure. Specifically, it involves evaluating the effects of plowing speed on the physical parameters of the soil such as: the grain size, water content, organic matter content, bulk density, porosity, and

Formatted: English (United States)

Formatted: English (United States)

permeability. To achieve these different objectives, an experimental approach was carried out: the installation and description of the soil profile, the choice of the plowing depth, the choice of the various speeds, the choice of the experimental device, and the measurement of the physical parameters of the soil.

Formatted: English (United States)

2.1. MATERIALS AND METHOD

2.1.1. Presentation of the study site

The study site (Fig. 1) is located in the Sudano-Guinean zone, towards the northern end of the Benin Plateau between latitudes 7°10' and 7°41' 17" North on the one hand and longitudes 2°24' 24" and 2°47'40" East on the other hand (IGN, 2020).

Formatted: English (United States)

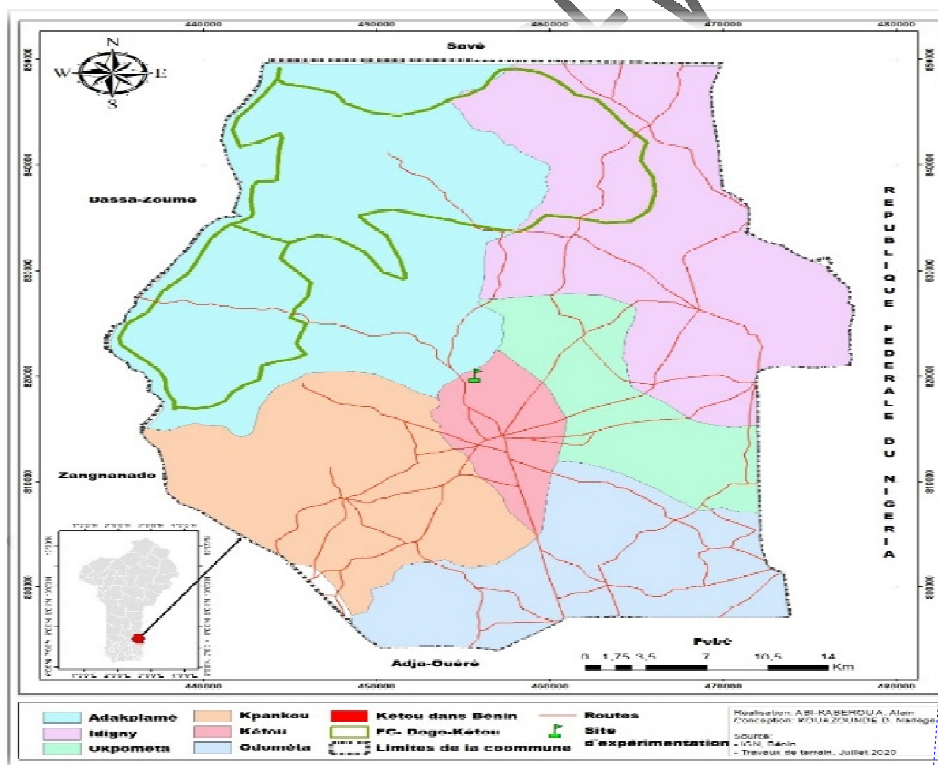

Figure 1: Geographic location of the study site

Source: IGN2020 (National Institute of Geographic and Forest Information),

Benin Plateau

2.1.2. Description of the experimental protocol

The adopted experimental protocol is a ~~complete~~ ~~completely~~ random block with total randomization with 2 factors, ~~the~~ random factor which is the block, and fixed factor which is the speed of plowing. In this study, the main plot is (2124 m²) in area, inside this plot we have three blocks separated by (3 m) alleys to allow the passage of the tractor. Each block ~~each~~ contains seven elementary plots of (40 m²) in ~~an~~ area separated by (3 m) alleys to allow the passage of the tractor. ~~The~~ (Fig. 2) below illustrates the experimental device adopted. Plowing is carried out with a 3-body ploughshare plow with a working width of (1.20m), hitched to a 60 HP agricultural tractor.

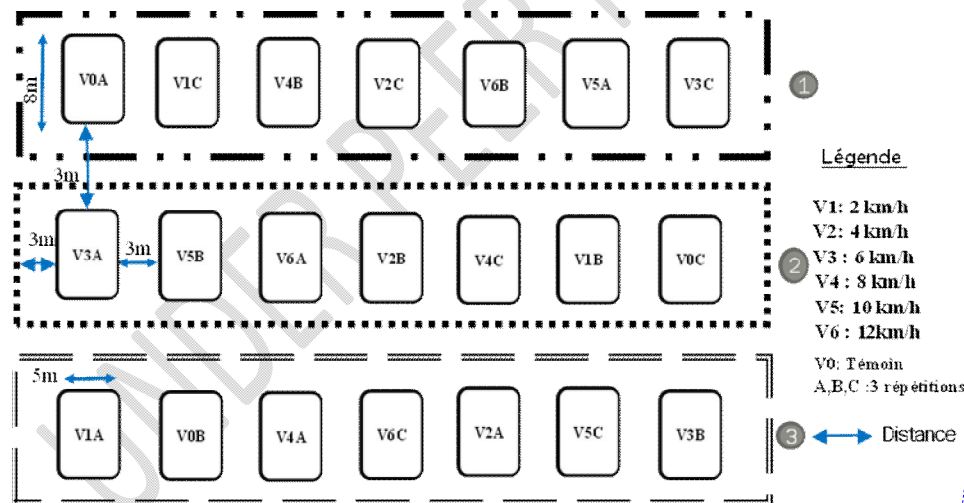

Figure 2: Diagram of the experimental device of the test: Complete random block (BAC)

Legend: V1 - Speed 2Km/h, V2 - Speed 4km/h, V3 - Speed 6km/h, V4 - Speed 8km/h, V5 - Speed 10km/h, V6 - Speed 12km/h, V0 - No speed, A, B, C - Repetition of treatments.

2.1.3. Sample Collection Methods

The cultural profile was examined from the wall of a pit following the steps of (Delaunois, 2008). The cultural profile of (1.5m wide, 2m long and 1m deep) was installed to measure the depth of the topsoil. The depth of topsoil measured is (25 cm), so the plowing depth retained is (20 cm). Regarding the soil analysis tests (particle size analysis, Atterberg limits and organic matter), reworked soil samples are taken using a manual auger per plot following the diagonal of each plot at three points starting from both ends of the diagonal to finish in the middle. These samples taken per plot are mixed to have a representative sample per plot and then per treatment. For the water content and bulk density tests, the samples are taken using a metal cylinder with a diameter of (100 mm) and a height of 10 cm to a depth of 20 cm by manual coring. In addition, the two orifices of the cylinders are hermetically closed to maintain the humidity and the density of the soil in place and the whole until the moment of the analyses in the laboratory.

Measurements made at ground level

- Particle size analyzes

It was carried out up to (80 μ m) by sieving the material by dry process (for large grains) or by wet process (for materials containing particles less than 0.063 mm) according to standard NF EN ISO 17892-4.2018.

- Atterberg limits

The Atterberg limits conventionally translate the differences in the behavior of a soil according to its water content. They apply to the soil, the elements of which pass through a (400 μ m) mesh sieve according to standard NF EN ISO 17892.2018. The Atterberg limits are determined using the plasticity index I_p which measures the range

Formatted: English (United States)

Formatted: English (United States)

of water content in which the soil is found in the plastic state. It is determined by the following expression:

$$I_p = w_l - w_p \mathbf{(1)}$$

- w_l represents the liquidity limit; - w_p represents the plastic limit

- **Water content by weight (w)**

It represents the ratio of the mass of water evaporated during steaming (M_w) to the mass of solid grains (M_d), obtained according to standard NF P 94-050.1995. The mass of solid grains is obtained after 4 hours of drying in the oven at (105°C). The water content by weight is expressed as a percentage and is determined by the following formula:

$$W = M_w / M_d * 100 \mathbf{(2)}$$

With

W : the water content by weight; M_w : mass of water; M_d : the mass of solid grains.

- **Organic matter content (OM)**

The test is carried out on particles with a diameter of less than (0.400 mm) according to standard NF XP P 94-047.1998. It is carried out using equipment consisting of a graduated cylinder, a tare, a Biomax solution, a stirrer, an oven, and an electronic balance. The MO content is expressed as a percentage and is determined by the following formula:

$$MO = (M_i - M_f) / M_i * 100 \mathbf{(3)}$$

With

MO : Organic Matter; M_i : Initial mass before parboiling; M_f : Final mass after parboiling.

- **Soil Bulk Density**

It is determined according to standard NF EN 1097-3.1998.

Formatted: English (United States)

The formula for determining the bulk density of soil is given by the expression below:

$$Da = (P2-P1)/V(4)$$

- $P2$: is the total weight of the sample; - $P1$: is the weight of the empty box; - V : is the volume of the box.

- **Soil porosity**

It is conducted according to standard NF EN 1097-6.2001 and is determined by the following formula:

$$Porosity = 1 - [(da)/((1+w)*ys)] \quad (5)$$

With

da : apparent density; w : water content; Ys : actual density.

- **Soil hydraulic conductivity**

The test consists in measuring the evolution of the infiltration over time of a sheet of water under constant load, infiltrating vertically into the ground. It is based on the principle of the müntz method (Colombaniet *al.*, 1972), also called double müntz rings.

It is obtained by the formula:

$$Ks = Hi/tc(6)$$

where Hi is the depth of infiltrated water and Tc , the cumulative duration.

2.1.4. Statistical analysis and data processing

All the statistical analyzes were carried out with the R software (R Core Team, 2019) and the level of significance of the statistical tests was set at 5%. First, we performed the correlation test between the physical properties of the soil in order to see the relationship between them. The analysis of variance made it possible to compare the influence of the plowing speed for each parameter evaluated. As for the other physical

4		0.439 (0.43)a		
6		0.442 (0.43)a		
8		0.449 (0.44)a		
10		0.436 (0.42)a		
12		0.433 (0.42)a		
0	Organic Matter Discs (%)	0.437 (0.012)a	1.57	0.009
2		0.274 (0.012)a		
4		0.312 (0.012)a		
6		0.324 (0.012)a		
8		0.312 (0.012)a		
10		0.299 (0.012)a		
12		0.274 (0.012)a		

As for the results of the Kruskal Wallis tests in Table 2, it appears for the soil plowed with these tools that by negative correlation, the plowing carried out at high speeds presents low levels of organic matter with reduced soil densities, while by correlation positive, plowing carried out at high speeds presents the lowest plasticity indices with a low rate of organic matter. Thus, by positive correlation, plowing carried out at slow speed presents the lowest indices of plasticity and organic matter for the soil plowed with discs with a high soil density; the soil plowed with ploughshares has a lot of organic matter, is less dense with a high plasticity index. However, speeds of 6 km/h give the best water content, organic matter, indices, densities, and average porosities. The speed of 6 km/h defines the best physical ground conditions leading to good performance, unlike other speeds.

Table 2: Kruskal Wallis test results. SD - standard error, χ^2 - Chi-square statistic, DF - degree of freedom, Prob - probability, the averages followed by the same letters are not different by only 5%.

Speed (km/h)	Property	Mean (SD)	χ^2 (DF=6)	prob	Speed (km/h)	Property	Mean (SD)	χ^2 (DF=6)	prob
0	Organic matters	0.304 (0.004)a	17.09	0.008	0	Soil porosity	0.458 (0.012)a	8.79	0.1
2	Shares	0.207			2	(%)	0.438		

Formatted: Space After: 0 pt, Line spacing: single

Formatted: Space After: 0 pt, Line spacing: single

Formatted ... [23]

Formatted ... [24]

Formatted ... [25]

Formatted ... [26]

Formatted ... [27]

Formatted ... [28]

Formatted ... [29]

Formatted ... [30]

Formatted ... [31]

Formatted ... [32]

Formatted ... [33]

Formatted ... [34]

Formatted ... [35]

Formatted ... [36]

Formatted ... [37]

Formatted ... [38]

Formatted ... [39]

Formatted ... [40]

Formatted ... [41]

Formatted ... [42]

Formatted ... [43]

Formatted: English (United States)

Formatted: English (United States)

Formatted: English (United States)

Formatted: Line spacing: single

Formatted: English (United States)

Formatted: Line spacing: single

Formatted: English (United States)

Formatted: English (United States)

Formatted: Line spacing: single

Formatted: English (United States)

Formatted: Line spacing: single

Formatted: English (United States)

Formatted: Line spacing: single

Formatted: Line spacing: single

	(%)	(0.003)ab					(0.006)a	
4		0.305 (0.002)a			4		0.439 (0.006)a	
6		0.304 (0.004)a			6		0.442 (0.009)a	
8		0.103 (0.003)b			8		0.449 (0.016)a	
10		0.105 (0.003)b			10		0.436 (0.006)a	
12		0.106 (0.003)b			12		0.433 (0.004)a	
0		1.346 (0.002)d			0		9.505 (0.003)ab	
2		1.385 (0.005)bc			2		10.007 (0.003)a	
4		1.383 (0.003)c			4		9.007 (0.002)c	
6	Soil density(%)	1.357 (0.002)cds	18.74	0.004	6	Plasticity index(%)	10.003 (0.002)a	18.22
8		1.395 (0.005)a			8		9.004 (0.004)c	0.0
10		1.394 (0.002)ab			10		9.006 (0.003)c	
12		1.354 (0.004)d			12		9.001 (0.000)c	
0		1.405 (0.002)ab			0		10.1 (0.000)a	
2		1.407 (0.001)a			2		9.1 (0.000)d	
4		1.398 (0.003)c			4		9.0 (0.000)e	
6	Disc soil density (%)	1.395 (0.001)cds	178.15	0.001	6	Disc plasticity index (%)	9.2 (0.000)c	3.21
8		1.385 (0.001)e			8		9.3 (0.000)b	0.0
10		1.394 (0.003)d			10		9.3 (0.000)b	
12		1.403 (0.0001)b			12		9.0 (0.000)e	

3.1. Particle size analysis

Formatted	[... [46]
Formatted	[... [47]
Formatted	[... [50]
Formatted	[... [51]
Formatted	[... [44]
Formatted	[... [45]
Formatted	[... [48]
Formatted	[... [49]
Formatted	[... [54]
Formatted	[... [58]
Formatted	[... [55]
Formatted	[... [59]
Formatted	[... [52]
Formatted	[... [56]
Formatted	[... [53]
Formatted	[... [57]
Formatted	[... [62]
Formatted	[... [63]
Formatted	[... [66]
Formatted	[... [67]
Formatted	[... [60]
Formatted	[... [61]
Formatted	[... [64]
Formatted	[... [65]
Formatted	[... [70]
Formatted	[... [74]
Formatted	[... [71]
Formatted	[... [75]
Formatted	[... [68]
Formatted	[... [69]
Formatted	[... [72]
Formatted	[... [73]
Formatted	[... [78]
Formatted	[... [79]
Formatted	[... [82]
Formatted	[... [83]
Formatted	[... [76]
Formatted	[... [77]
Formatted	[... [80]
Formatted	[... [81]
Formatted	[... [84]
Formatted	[... [85]
Formatted	[... [88]
Formatted	[... [89]
Formatted	[... [92]
Formatted	[... [93]
Formatted	[... [86]
Formatted	[... [87]
Formatted	[... [90]
Formatted	[... [91]
Formatted	[... [96]

The (Fig. 3) below illustrates the plotted particle size analysis curves. It presents the percentage of passers-by as a function of the different sieve meshes at different plowing speeds with a ploughshare plow.

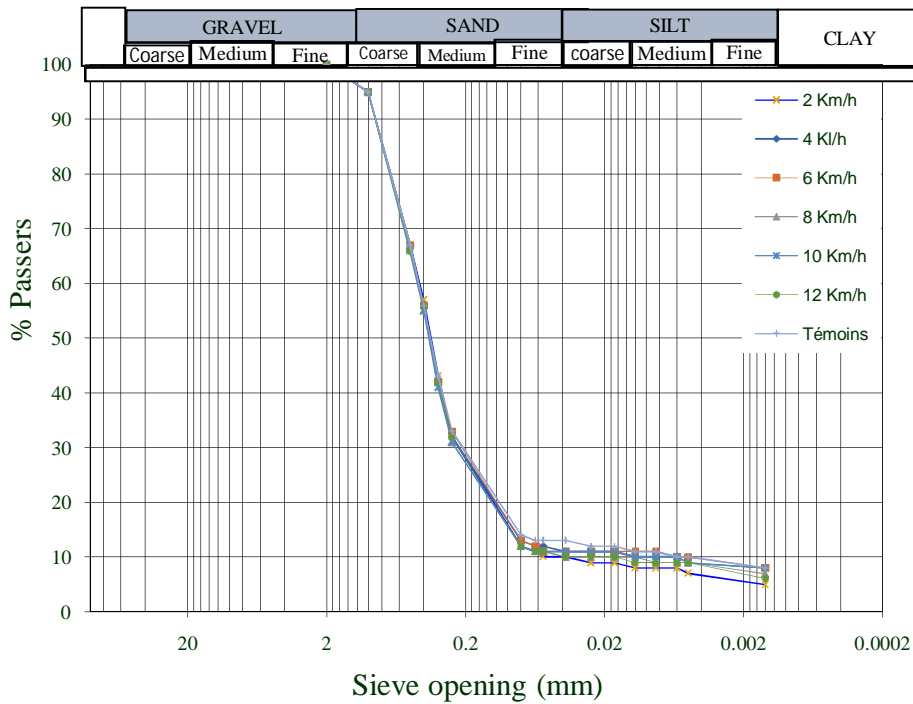

Formatted: English (United States)

Figure 3: Particle size analysis curve of the ~~different~~ different plowing speeds

Formatted: English (United States)

Legend : V1 - Speed 2Km/h, V2 - Speed 4km/h, V3 - Speed 6km/h, V4 - Speed 8km/h, V5 - Speed 10km/h, V6 - Speed 12km/h, V0 - No speed, no plowing.

Plowshare plowing therefore did not lead to a change in grain size. Thus, the plowing speed factor does not influence the grain size. Moreover, the particle size analysis does not make it possible to characterize the particles having sizes less than 80 μm (fine

particles). Characterization tests on fine soils (the Atterberg limits) will certainly allow us to classify these particles.

3.2. Characterization of soils according to the Atterberg limits

The (Fig. 4) presents the different values obtained for the limits of liquidity and plasticity and which are represented in the plasticity diagram of Casagrande.

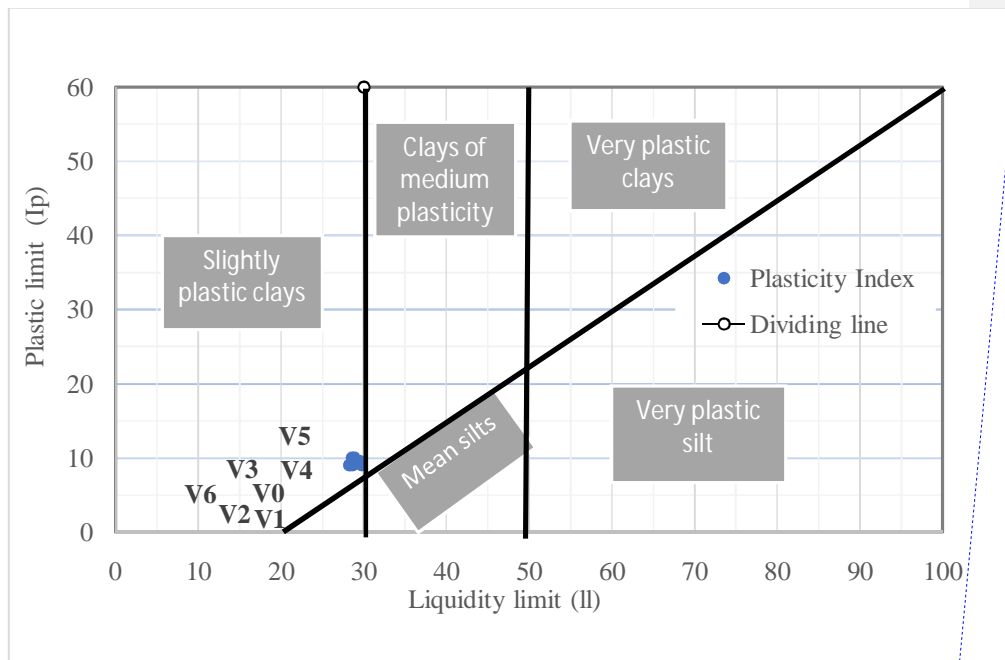

Formatted: English (United States)

Figure 4: Liquidity and plasticity limits in the Casagrande plasticity diagram

Legend: V1 - Speed 2Km/h, V2 - Speed 4km/h, V3 - Speed 6km/h, V4 - Speed 8km/h, V5 - Speed 10km/h, V6 - Speed 12km/h, V0 - No speed, no plowing.

The plasticity diagram of Casagrande, allowed us to identify through these values, the various fine particles of passers-by resulting from the granulometric analysis of each parcel. Note that the fine particles of passers-by from V0 to V6 all belong to the class of less plastic clays.

Indeed, the plowing speed does not significantly influence the plasticity index at the (5%) threshold (Table.2). Moreover, it is seen that the action of the tool (ploughshares and discs) on the ground, did not change the class of the fine particles of the ground, which confers on it the same character. Furthermore, the presence of clay soil with low plasticity at the level of plots V0 to V6, will make them impermeable and poorly ventilated and then form an obstacle to root penetration but with a good capacity to transport water by capillary action from the deep layers. Clay soil is an ideal seedbed for cotton, because its surface is friable and has fine water-stable clods, which allows quick and uniform emergence of seedlings (Daniel, 1998).

3.3. Evaluation of soil permeability

The Figure 5 below shows that the best permeability is obtained with the two tools at a speed of 6 km/h on ferralitic soil. However, the soil worked by the ploughshare plow has a more permeable layer.

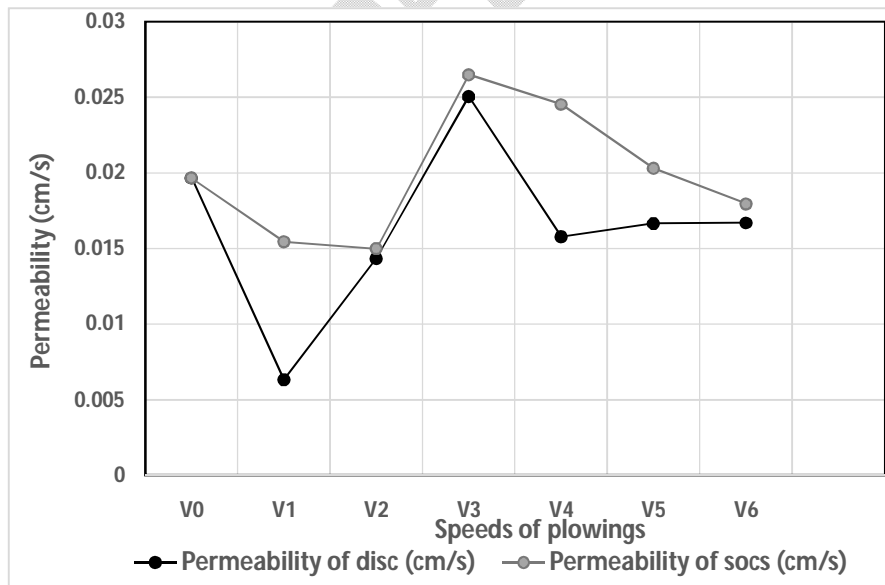

Formatted: English (United States)

Figure 5: Permeability of plowed soil to coulters and discs as a function of plowing speed

Legend: V1 - Speed 2Km/h, V2 - Speed 4km/h, V3 - Speed 6km/h, V4 - Speed 8km/h, V5 - Speed 10km/h, V6 - Speed 12km/h, V0 - No speed, no plowing.

It can be seen that, from V0 to V2, V3 to V6, the permeability is inversely proportional to the plowing speed. In addition, the maximum permeabilities are obtained at the level of V3 (6 km/h). Thus, the soil must be permeable especially at the level of the root zone and impermeable at the level of the basement in order to avoid too deep drainage. So, plowing at a speed of 6 km/h made it possible to obtain good soil permeability. We observe that at slow speeds, it is less, this is justified by the fact that the plowing by the plows has created fewer pores following a lesser dislocation of the earthen clods of the arable layer, giving enough difficulties to the water to cross them.

4. DISCUSSION

Optimal tillage speed results in marked improvement in soil physical properties, good root system extension, nutrient efficiency, and improved germination and productivity (Nadjid, 2010). Low or high, plowing speeds reflect effects on the conservation of soil organic matter, humidity and water capillary capacity, and soil bulk density (Jasim *et al.*, 2015; Mahmoudi, 2015). Indeed, there is a correlation between the characterizations characterization's parameters considered. Plowing at a slow (2 km/h) or fast (8 to 12 km/h) speed leads to a decrease in the water content of the soil, the porosity and the rate of organic matter and an increase in the apparent density of the soil and consequently lower yields with the ploughshare. Plowing at an average speed (6 km/h) leads to an increase in permeability, water content, organic matter content and

Formatted: English (United States)

Formatted: English (United States)

Formatted: English (United States)

soil porosity with a decrease in bulk density, thus leading to a better yield. The results proved that the granulometry of the ground does not change following the variation of the speeds but on the other hand, they apparently act on these characteristics. However, with (Chehaibiet *al.*, 2008), having studied the effect of the forward speed of the tractor on the behavior of a loamy-sandy soil in the region of Chott-Mariem (Sousse) reveal that working at slow speed provides a much greater volume of plowed soil containing few voids at depth, therefore high compaction at depth, unlike high-speed tillage, which generates less compaction at depth with a reduced volume of soil worked. We see that there are fewer pores and a high density with the plow, hence a moderate infiltration rate, but with the disc plow, it is lower. We then note that the discs mix the soil much more and increase the fine particles, hence more voids. In addition, (Jasim *et al.*, 2015) ~~evaluating~~ ~~evaluated~~ the impact of tillage speed on the physical properties of clay-loam soil and maize yields and found that: operating speeds significantly affected soil bulk density and hydraulic conductivity values. As working speed increased, soil bulk density increased, and hydraulic conductivity decreased; and the best maize yield is obtained at the speed of (6 km/h) similar to our study. It therefore appears that the increase in the working speed generates an increase in the apparent density and a decrease in the conductivity of the soil. Thereby, working the soil at a medium speed can therefore lead to an increase in the hydraulic conductivity of the soil with a decrease in the bulk density and consequently a better yield. As a result, working at slow speed leads to a much larger volume of soil worked, leaving large aggregates containing many deep voids and consequently a reduction in energy consumption (Holland, 2004; Zokpodo *et al.*, 2017) without necessarily reducing crop yield. So, a good plowing at an average speed shows a better structured soil (Zokpodo *et al.*, 2017). (Jasim *et al.*,

Formatted: English (United States)

Formatted: English (United States)

2015) evaluated the impact of plowing speed on the physical properties of clay-loam soil and maize yields. They revealed that: operating speeds significantly affected soil bulk density and hydraulic conductivity values. As working speed increased, soil bulk density increased, and hydraulic conductivity decreased; and the best maize yield is obtained at a speed of (6 km/h). It therefore appears that the increase in the working speed generates an increase in the apparent density and a decrease in the conductivity of the soil. Thus, working the soil at an average speed can therefore lead to an increase in the hydraulic conductivity of the soil with a decrease in the bulk density and consequently a better yield. Soil bulk density increased, and hydraulic conductivity decreased; and the best maize yield is obtained at a speed of (6 km/h). It therefore appears that the increase in the working speed generates an increase in the apparent density and a decrease in the conductivity of the soil. Thus, working the soil at an average speed can therefore lead to an increase in the hydraulic conductivity of the soil with a decrease in the bulk density and consequently a better yield. Soil bulk density increased, and hydraulic conductivity decreased; and the best maize yield is obtained at a speed of (6 km/h). It ~~therefore, therefore,~~ appears that the increase in the working speed generates an increase in the apparent density and a decrease in the conductivity of the soil. Thus, working the soil at an average speed can therefore lead to an increase in the hydraulic conductivity of the soil with a decrease in the bulk density and consequently a better yield. On the other hand, (Namdari *et al.*, 2010) evaluated the effect of plowing depth and speed using a moldboard plow on the quality of tillage of a loamy-sandy soil. The depth and speed of plowing are therefore two determining factors in the quality of tillage. Thus, plowing at a speed of (5.5 km/h) for this author generates an improvement in the rate of soil inversion and a reduction in the weight average diameter

Formatted: English (United States)

of the clods with a plowing depth of (15-20 cm) thus leading to the improvement in the quality of tillage. On the other hand,(Kadhimetal.,2010),~~shows show~~that increasing the tillage speed to (7 km/h) causes a significant decrease in the weight diameter of the clods and in the total porosity. From all the above we see that the speed of tillage influences the structure of the soil in the sense that slowly it provides a ~~better structured~~better-structured soil with soil turning and greater working depth leading to a better yield. Quickly, it generates a reduced volume of worked soil associated with a reduction in the weight diameter of the clods of earth, the conductivity and the porosity of the soil with an increase in the apparent density of the soil. By 2030, the FAO envisages for states to minimize the costs associated with healthy and diversified production. To do this, it is necessary to encourage: the promotion of equipment systems adapted to the soil and good methods of driving agricultural machinery, the manufacture of simple machines for working the soil at a lower cost, increasing productivity through innovative techniques to ensure good sustainability while meeting the requirements of healthy, balanced nutrition of the poor population and environmental protection (FAO, 2014). Thus, the investigations have proven that reducing plowing to a minimum frequency and carrying it out at an optimal speed are necessary for mechanization which ensures optimum production and sustainable agriculture.

Formatted: English (United States)

Formatted: English (United States)

I suggest incorporating the following paragraphs that would improve the scientific quality of the manuscript. I continue to add a paragraph that summarizes the importance, usefulness and social relevance, contemporary of the study, specifically pointing out the Impact, Benefit and Projection, something like this (for example):

Formatted: Font: (Default) Arial

Formatted: Font: (Default) Arial

Formatted: English (United States)

Plowing, or the act of turning over the soil using a plow, can have a significant impact on the quality of tropical soils (Olivares et al. 2020; Olivares et al. 2022a). One of the

main effects of plowing is the destruction of soil structure, which can lead to increased erosion and reduced water retention capacity (Olivares et al. 2022b; Olivares, 2022; Olivares et al. 2016). This can make the soil less fertile and less able to support plant growth. Another effect of plowing is the disruption of the soil's natural microbial communities (Olivares et al. 2021a; 2021b). These communities play a critical role in nutrient cycling and the overall health of the soil. Plowing can lead to a loss of these beneficial microorganisms, which can further decrease soil fertility (Olivares et al. 2022c).

Additionally, plowing can also lead to the release of stored carbon, which can contribute to climate change (Olivares et al. 2019; Olivares and López, 2019). The destruction of soil organic matter through plowing can result in the release of large amounts of carbon dioxide and other greenhouse gases (Olivares et al. 2017; Olivares et al. 2012). On the other hand, plowing can also have some positive effects on tropical soils. For example, it can help to control weeds and pests (Bertorelli and Olivares, 2020; Olivares et al. 2022d), and it can also aid in the incorporation of organic matter and other soil amendments.

Overall, the effects of plowing on tropical soils are complex and depend on a variety of factors, including the type of soil, the intensity and frequency of plowing, and the specific management practices used. Careful management and conservation practices can help to minimize the negative effects of plowing and maintain the quality of tropical soils.

5. CONCLUSION

The results obtained show that the plow/disc plowing speed has an impact on soil physics. This research has made it possible to prove that plowing at a very slow or fast speed leads to a reduction in the water content of the soil, the porosity, the rate of organic matter, and consequently a drop in yields. Plowing with the plow on the ferralitic soil at an average speed of (6 km/h) generates on the other hand an increase in the rate of organic matter, the porosity, the water content, and the permeability with a decrease in the apparent density of the soil. Which will definitely lead to a good yield. Finally, we can conclude that in the agro-pedological and climatic conditions specific to our trial, working at a speed of 6 km/h guarantees good physical soil conditions leading to better cotton yield.

All this ~~to contribute~~contributes to the mastery of appropriate farming mechanization techniques in ~~a the~~context of soil sustainability.

6. REFERENCES

I suggest adding recent references which address the issue in question in Latin American territories. Suggested citations are for genuine scientific reasons that emphasize the current topic of study in context:

6. Bertorelli, M., B.O. Olivares. 2020. Population fluctuation of *Spodoptera frugiperda* (J.E. Smith) (Lepidoptera: Noctuidae) in sorghum cultivation in Southern Anzoategui, Venezuela. *Journal of Agriculture University of Puerto Rico.*, 104(1):1-16. <https://doi.org/10.46429/jaupr.v104i1.18283>

Formatted: English (United States)

Formatted: English (United States)

Formatted: English (United States)

Formatted: Font: (Default) Arial, Bold

Formatted: Normal, No bullets or numbering

Formatted: English (United States)

Formatted: Indent: Left: 0.38", No bullets or numbering

- Jasim, AR., ASAti, HA Jabbar & K.Zenam. 2015. The Effect of Furrow Opener (Ridge), operation speed and samples depth on soil physical properties and maize yield, *Elixir Agriculture* 79, 30319-30322.
- Chehaibi, S., RTrija, JG Pieters & RA Verschoore. 2002. Feasibility of low power machinery in the Tunesian Sahel region. 8th PhD Symposium. Agricultural and Applied Biological Sciences. Gent University, Belgium. 5p.
- Chehaibi, S., C Hannachi, JG Pieters & RA Verschoore. 2008. Impacts of tractor forward speed on soil structure and yield of a potato crop. *Tropicultura*, 26 (4) 195-199 p.
- Colombani, J., JP Lamagat & J Thiebaut. 1972. Measurement of the permeability of soils in place: a new device for the Müntz measurement. An extension of the Porchet measure to heterogeneous soils. *Hydrological Sciences Bulletin*, vol 18, 197-235p.
- Damien, B. 2017. Adjusting your plow properly; plowing and weed management: the right plow settings, Arvalis, Plant Institute, 2p.
- Delaunois, A. 2008. Guide for the description and evaluation of soil fertility. Chamber of Agriculture, INRA Montpellier 81, 1-37.
- OECD/FAO. 2016. "Agriculture in Sub-Saharan Africa: Prospects and challenges for the next decade", in *OECD-FAO Agricultural Outlook 2016-2025*, OECD Publishing, Paris.
- FAO. 2014. Integrated Cotton Pest and Production Management, Facilitator's Guide to Farmer Field Schools, E-ISBN 978-92-5-108281-1, 36p.

- FAO. 2019. National Agricultural Mechanization Strategy in Benin. Technical Cooperation Program – FAO. TCP/BEN/3707/C2TCP/BEN/3703. Ministry of Agriculture, Livestock and Fisheries. 91p.
- Feddal, AB. 2011. Analysis of soil behavior under the action of two techniques for establishing a cereal crop. Master's thesis, National School of Agronomy El-Harrach. Algeria, 174 p.
- Huwe, B. 2003. The role of soil tillage for soil structure. *Soil Tillage in Agro ecosystems*. Pp 27 -50.
- Köller, K. 2003. Techniques of Soil Tillage, *Soil Tillage in Agro-ecosystem* CRC Pp. 1 - 25.
- Lal, R., DC Reicosky&JD Hanson.2007. Evolution of the plow over 10,000 years and the rationale for no-till farming. *Soil and Tillage Research* 93:1-12.
- MAEP. 2019. National Strategy for e-Agriculture in Benin 2020-2024. 57p. <https://www.google.com>.
- Mahmoudi, A., A. Jalali, M. Valizadeh&I. Skandari. 2015. The effects of forward speed and depth of conservation tillage on soil bulk density: *Journal of Agricultural Machinery* Vol. 5, No. 2, Fall-Winter, 368-380p.
- Majid, N., R Shahin & A Jafari. 2010. Effect of plowing depth and plowing speed on tillage quality. *Conferences papers*. Researchgate. 1-10p.
- Naseer, S., A Kadhim, & K Subr. 2021. Effect of tillage with chisel plow on soil mean weight diameter and porosity. *The Iraqi Journal of Agricultural Sciences* 33 (3): 33-41.
- Olivares B, Rey JC, Lobo D, Navas-Cortés JA, Gómez JA, Landa BB. 2021. *Fusarium Wilt of Bananas: A Review of Agro-Environmental Factors in the*

- Venezuelan Production System Affecting Its Development. *Agronomy*, 11(5):986. <https://doi.org/10.3390/agronomy11050986>
- Olivares B, Vega A, Calderón MAR, Rey JC, Lobo D, Gómez JA, Landa BB. 2022c. Identification of Soil Properties Associated with the Incidence of Banana Wilt Using Supervised Methods. *Plants*, 11(15):2070. <https://doi.org/10.3390/plants11152070>
 - Olivares B. 2016. Description of soil management in agricultural production systems of sector Hammock in Anzoátegui, Venezuela. *La Granja: Revista de Ciencias de la Vida*. 23(1): 14–24. <https://doi.org/10.17163/lgr.n23.2016.02>
 - Olivares, B. 2022. Determination of the potential influence of soil in the differentiation of productivity and in the classification of susceptible areas to banana wilt in Venezuela. *UCOPress: Spain*, pp. 89-111, <https://helvia.uco.es/handle/10396/22355>
 - Olivares, B., Araya-Alman, M., Acevedo-Opazo, C. et al. 2020. Relationship Between Soil Properties and Banana Productivity in the Two Main Cultivation Areas in Venezuela. *J Soil Sci Plant Nutr*. 20 (3): 2512-2524. <https://doi.org/10.1007/s42729-020-00317-8>
 - Olivares, B., Lobo, D., Cortez, A., Rodríguez, M.F. y Rey, J.C. 2017. Socio-economic characteristics and methods of agricultural production of indigenous community Kashaama, Anzoategui, Venezuela. *Rev. Fac. Agron. (LUZ)* 34 (2): 187-215. <https://n9.cl/p2gc5>
 - Olivares, B., López, M. 2019. Normalized Difference Vegetation Index (NDVI) applied to the agricultural indigenous territory of Kashaama, Venezuela. *UNED Research Journal*. 11(2): 112-121. <https://doi.org/10.22458/urj.v11i2.2299>

- [Olivares, B., López-Beltrán, M., Lobo-Luján, D. 2019. Cambios de usos de suelo y vegetación en la comunidad agraria Kashaama, Anzoátegui, Venezuela: 2001-2013. Revista Geográfica De América Central. 2\(63\):269-291. DOI: <https://doi.org/10.15359/rgac.63-2.10>](#)
- [Olivares, B., Paredes, F., Rey, J., Lobo, D., Galvis-Causil, S. 2021. The relationship between the normalized difference vegetation index, rainfall, and potential evapotranspiration in a banana plantation of Venezuela. SAINS TANAH - Journal of Soil Science and Agroclimatology. 18\(1\), 58-64. <http://dx.doi.org/10.20961/stjssa.v18i1.50379>](#)
- [Olivares, B., Parra, R., Cortez, A., Rodríguez, M.F. 2012. Patrones de homogeneidad pluviométrica en estaciones climáticas del estado Anzoátegui, Venezuela. Revista Multiciencias. 12 \(Extraordinario\): 11-17. <https://n9.cl/xbslq>](#)
- [Olivares, B.O., Calero, J., Rey, J.C., Lobo, D., Landa, B.B., Gómez, J. A. 2022b. Correlation of banana productivity levels and soil morphological properties using regularized optimal scaling regression. Catena. 208: 105718. <https://doi.org/10.1016/j.catena.2021.105718>](#)
- [Olivares, B.O.; Rey, J.C.; Perichi, G.; Lobo, D. 2022a. Relationship of Microbial Activity with Soil Properties in Banana Plantations in Venezuela. Sustainability; 14, 13531. <https://doi.org/10.3390/su142013531>](#)
- [Olivares, B.O.; Vega, A.; Rueda Calderón, M.A.; Montenegro-Gracia, E.; Araya-Almán, M.; Marys, E. 2022b. Prediction of Banana Production Using Epidemiological Parameters of Black Sigatoka: An Application with Random Forest. Sustainability 14, 14123. <https://doi.org/10.3390/su142114123>](#)

Formatted: English (United States)

Formatted: Font: (Default) Times New Roman, 12 pt, English (United States)

- Pussemier, L., L. Goeyens. 2017. Agriculture and social issues. Gembloux Agronomy. Pottinger Land technikGmbtt, 2p.
- RNDG 2015. National Human Development Report. Agriculture, Food Security and Human Development in Benin. Govt.Benin, UNDP. 1p.
- Seine, M. 2013. Contribution of advisers in organic field crops from the Interdepartmental Chamber of Agriculture of Ile-de-France. Bio-plain. No. 30 – October 18, 5p.
- Zokpodo KLB, AY Akossou, DE Dayou&W Meadan. 2017. Impact of the motorized plowing on the structure of tropical ferruginous soils and the efficiency of a corn culture (*Zea mays*, L.) in the N'Dali Township in North-Benin. Article of Asian Journal of Science and Technology. 3Vol. 08, Issue, 05. Pp 4828 – 4834.

Formatted: English (United States)

UNDER PEER REVIEW

