

---

# Multi-case finite element analysis of spillway table hole working gates

**Abstract:** The arc gate is a complex space system, the gate adopts two support arm structure and cylindrical hinge support, the arrangement of the support arm, the size of the orifice size and the effect of the high and low water head have a large impact on its working characteristics, this paper takes the spillway table hole arc gate as the research object, using the finite element method to determine the water load on the gate components in the ordinary working condition, earthquake working condition and opening and closing working condition, and according to the calculation results to solve the internal force of each building, the calculation results show that under the design head, the strength and stiffness of the spillway table hole arc gate in the three working conditions meet the relevant requirements.

**KEYWORDS:** Spillway meter hole; Arc gates; Seismic conditions; Opening and closing conditions; Finite element analysis

## 0 Introduction

The gate is an active component used to control the opening and closing of water crossing holes in hydraulic buildings, and is commonly used to control the flow and regulate the water level, etc. The curved working gate has the advantages of light structure<sup>[1]</sup>, stable operation and effort-saving opening and closing, and is therefore widely used in hydraulic buildings. The safety of the gate affects the operation of the whole hydraulic building<sup>[2]</sup>, the current hydraulic gate design code is a planar system algorithm, the code is now difficult to meet the large gate working conditions force calculation, and three-dimensional finite element method is a more accurate, economic and convenient gate structure force analysis method, many researchers to carry out research on this.

Xu Z W et al<sup>[3]</sup> analysed a three-dimensional finite element linear model of a planar steel gate from two aspects: finite element meshing and simplification of the leakage hole structure. Xu X et al<sup>[4]</sup> used Fluent to construct a three-dimensional model of the gate-air-water to study the flow field distribution and force situation in the opening and closing stages of the herringbone gate. Li Q<sup>[5]</sup> et al established gate cloud diagrams based on hierarchical analysis ideas and intuitive fuzzy theory combined with engineering examples to assess the safety state of gates. Cao H Y et al<sup>[6]</sup> used the finite element internal force method to calculate the interaction forces of each main force-bearing component of the arc gate and compared it with the calculation structure of the plane system method. The above researchers have all contributed to the numerical study of gates, but all have done so to consider the difference between gates in special operating conditions and ordinary operating conditions.

This paper takes the spillway table hole arc gate as the main research object, combined with relevant design information, based on ANSYS finite element analysis software, the gate in the three working conditions of strength, stiffness calculation analysis, in order to provide reference for the actual arc gate three-dimensional finite element analysis research.

## 1 Project overview and finite element model

Spillway table hole working gate structure for table hole exposed top type arc gate, arc gate main structure for steel plate welding arc structure, design head 20.4m. spillway table hole working gate main technical parameters as shown in table 1.

Table 1 Main technical parameters of spillway table hole working gates

No.	Item	Technical characteristics	No.	Item	Technical characteristics
1	Orifice type	Surface hole exposed top type	2	Orifice size	13 × 21m (W × H)
3	Number of holes	5	4	Design head	20.4m
5	Total water pressure	2741.3t	6	Lift distance	11.7m
7	Support spacing	11m	8	Type of support hinge	Cylindrical hinge
9	Mode of operation	Dynamic water start/stop	10	Gate weight	186.5t
11	Opening force	2 × 220t	12	Arm type	Inclined support arms
13	Number of arms	2	14	Radius of curved surface	21m

As the arc gate is a complex space system, the gate adopts two support arm structure and cylindrical hinge support, the arrangement of the support arm, the size of the orifice and the head of the action have a large impact on its working characteristics, and the traditional gate structure theory design calculation method, each member of the gate alone for the calibration calculation, failed to fully consider the overall structure of the space role, can't truly reflect the force of the gate. There are certain limitations, and the calculation results have large errors. The modeling process omitted the support model and added corresponding constraints at the hinged position of the support to release the rotational degrees of freedom of the curved gate in the hinged position, as the preliminary research and analysis found that the fixed and movable hinge supports of the curved gate had sufficient safety factors. Therefore, this study used SolidWorks to build a 3D solid model of the spillway table hole curved gate and imported it into ANSYS Workbench to generate a 3D finite element model of the curved gate, based on which a finite element static simulation was carried out to check the strength and stiffness of the curved gate and to carry out strength and stiffness analysis according to the relevant design codes. The three-dimensional solid model of the spillway table hole arc gate is shown in Figure 1, the three-dimensional finite element model is shown in Figure 2, and the local mesh division cell is shown in Figure 3. From Fig. 1 and Fig. 2, it can be seen that the coordinate origin is at the midpoint of the two support hinge points, the X-axis points to the vertical direction of the water flow, the Y-axis points to the vertical upward direction and the Z-axis points to the upstream direction. From Fig. 3, it can be seen that in this calculation, the hexahedral element (Solid185 element) is used for meshing the regular structure, and the tetrahedral element (Solid187 element) is used for meshing the complex and irregular structure, and the finite element calculation accuracy is controlled by the mesh size to improve the calculation efficiency.

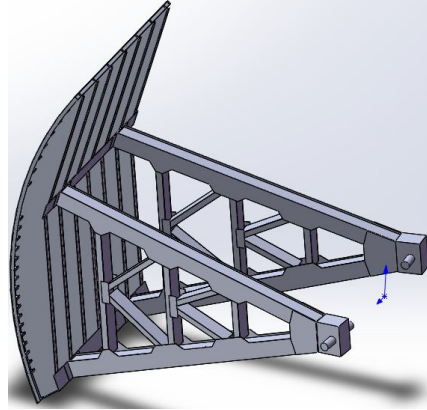

Figure 1 Arc gate 3D solid model

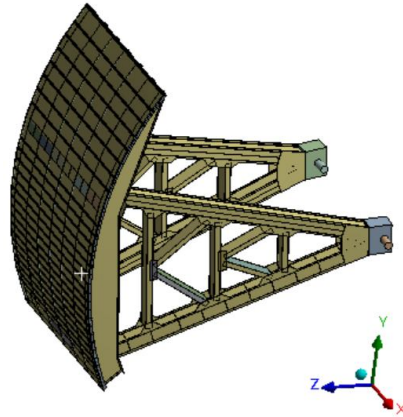

Figure 2 3D finite element model for arc gates

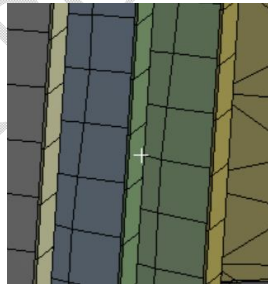

Figure 3 Partial meshing of cells

The arc gate is a steel plate welded structure, the main structural material is 16Mn, 16Mn steel belongs to carbon manganese steel, the content of carbon is around 0.16%, the yield point is equal to 343MPa, the grade is now Q345, so the material properties are modulus of elasticity  $E=206000\text{MPa}$ , Poisson's ratio  $\mu=0.3$ , mass density  $\rho = 7.85 \times 10^9 \text{ t} / \text{mm}^3$ .

## 2 Load and working condition analysis

### 2.1 Water pressure load

Water pressure acting on the external surface of the arc gate panel, the density of the water body taken  $1000 \text{ kg/m}^3$ , gravitational acceleration taken  $9.8 \text{ m/s}^2$ , arc panel distribution of water pressure according to the hydraulic head according to the following formula calculation.

$$p = \rho gh \quad (1)$$

where  $p$  is the water pressure,  $\rho$  is the density of the water body,  $g$  is the acceleration of gravity

and  $h$  is the head height.

The head of the curved gate is 20.4 m, the load dynamic coefficient is taken as 1.0. The water pressure width range is the panel width, the height range is the bottom edge of the panel to the normal high water level of 20.4 m, the water pressure gradually increases from 0 at the top to 0.2 MPa at the bottom, the water pressure is applied using the variable load in Pressure, the uppermost part of the panel water pressure is 0 (minimum), the lower part of the panel water pressure is 0.2 MPa (maximum), the water pressure load is applied as shown in Figure 4.

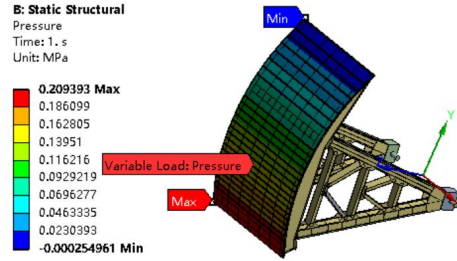

Figure 4 Hydrodynamic load applied

## 2.2 Self-weight load

The arc gate is mainly composed of gate leaf, support arm, support hinge device and water stop device, according to the drawing arc gate total weight 186,500kg, in ANSYS Workbench by applying gravitational acceleration to apply self-weight load, as shown in Figure 5.

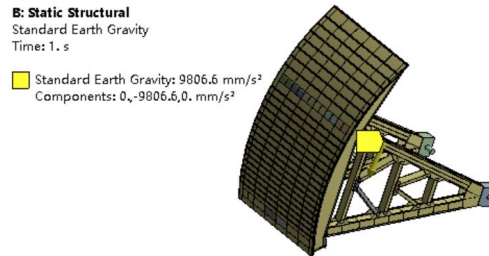

Figure 5 Self-weight load

## 2.3 Seismic loads

According to *Standard for seismic design of hydraulic structures GB51247-2018*<sup>[7]</sup>, The gate structure can be calculated only for horizontal seismic forces in the downstream flow direction, calculated as shown in equation (2). The basic seismic acceleration value for hydropower station design is  $0.4g$ .

$$E_i = a_h \xi G_{Ei} \alpha_i / g \quad (2)$$

where  $a_h = 0.4g$ ; The seismic force is therefore equivalent to a seismic acceleration of  $0.15 g =$

$1470 \text{ mm/s}^2$  applied horizontally to the curved gate for computational study.

## 2.4 Binding conditions

Bonded connection is used for most of the panels of the curved gate. Fixed support is applied at the bottom of the fixed hinge of the curved gate to constrain the 6 directional degrees of freedom; the contact between the movable hinge bearing and the shaft of the curved gate is simulated using revolute joint to release the axial (X-direction) degrees of freedom of rotation. The bottom of the gate panel is constrained to be displaced in the vertical (X-direction). The constraint conditions are imposed as shown in Figure 6.

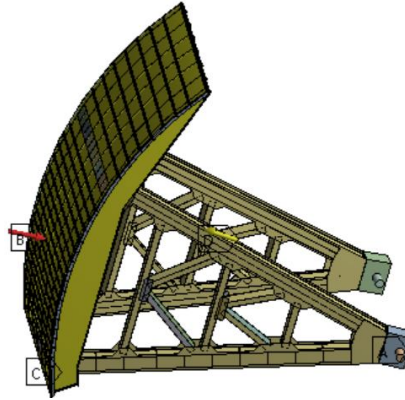

Figure 6 Constraint imposed

### 2.5 Analysis of working conditions

The calculated working conditions for the spillway table hole gates include normal working conditions and seismic conditions, with the loads and constraints applied as shown in Table 2.

Table 2 Calculation of working loads and constraints

Working condition number	Load			Binding		
	Hydraulic pressure	Self-weight	Earthquake	Fixed bearing fixing	Vertical at the bottom of the panel	Hinged
condition one: normal operation	√	√	×	√	√	√
Condition two: Earthquake	√	√	√	√	√	√

## 3 Analysis of finite element calculation results for normal operating conditions

### 3.1 Overall structural strength and stiffness checks

The stress and deformation clouds of the arc gate are shown in Figure 7, Figure 8 and Figure 9 respectively. As can be seen from Figure 7, the overall structure of the arc gate is mostly less than 150MPa, less than the material allowable stress 196.65MPa; as can be seen from Figure 8, the local stress concentration appears in the secondary beam and the panel and the main beam connection position, this position is mainly under pressure under load, the maximum local pressure stress is 279.66MPa, less than the local pressure allowable stress 299.25 MPa, so the overall structure of the curved gate meets the design specification requirements.

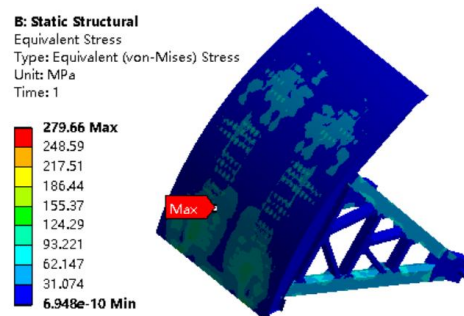

Figure 7 Overall structural stress cloud

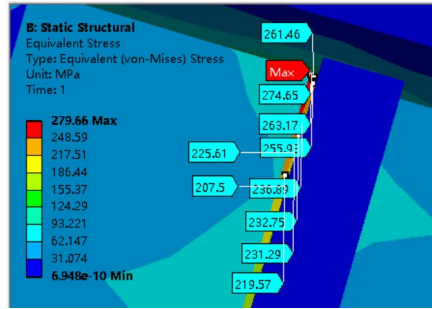

Figure 8 Local enlargement of concentrated stress

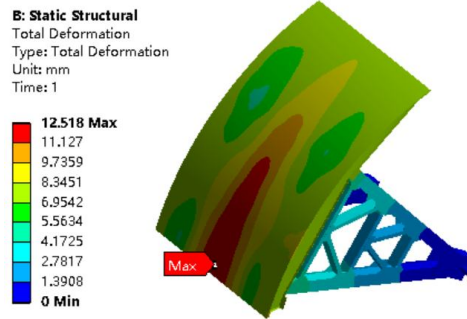

Figure 9 Overall structural displacement cloud

As can be seen from Figure 9, the maximum deformation of the overall structure of the curved gate is 12.5mm, and its deformation distribution trend is that the panel position is larger and the outrigger displacement is smaller, mainly because the panel is directly subjected to water pressure and the panel size is larger; at the same time, at the panel, the trend of gradually increasing deformation from the upper to the lower, from both sides to the middle is presented, which is mainly due to the gradual increase of water pressure from the upper to the lower of the panel, while the outrigger support is close to Both sides of the panel, the middle span of the panel is much larger than the cantilever length on both sides, so the displacement calculation structure is in line with the actual situation.

### 3.2 Structural strength and stiffness checks of secondary beams

The stress clouds of the secondary beam are shown in Figure 10 and Figure 11 respectively, and the displacement clouds are shown in Figure 12. From the stress cloud of the secondary beam, it can be seen that the X-axis primary stress of the secondary beam is the largest, but the local compressive stress is still less than the allowable local compressive stress, so the structural strength of the secondary beam meets the design code requirements.

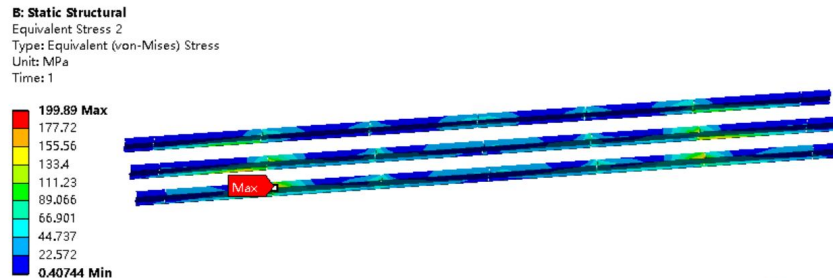

Figure 10 Secondary beam stress cloud

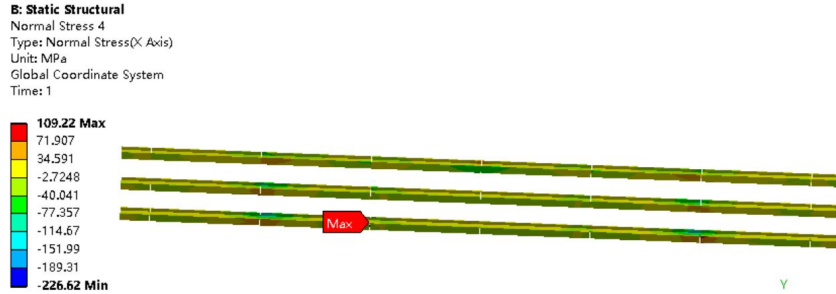

Figure 11 X-axis principal stress



Figure 12 Secondary beam structural displacement cloud

From Figure 12, the maximum displacement of the secondary beam is 12.3mm, the maximum displacement occurs in the middle of the secondary beam, the total length of the secondary beam is 12,762mm, the ratio of deflection to the calculated span is about 1/1037, far less than 1/250, which meets the design code requirements.

### 3.3 Structural strength and stiffness check of main beam

The stress cloud of the main beam is shown in Figure 13 and the displacement cloud is shown in Figure 14. From the stress cloud of the main beam, it can be seen that the maximum stress is 207.8MPa, and the maximum stress is at the connection between the lower secondary beam and the main beam, but the local compressive stress is still less than the allowable local compressive stress, so the structural strength of the main beam meets the design specification requirements.



Figure 13 Main beam stress cloud

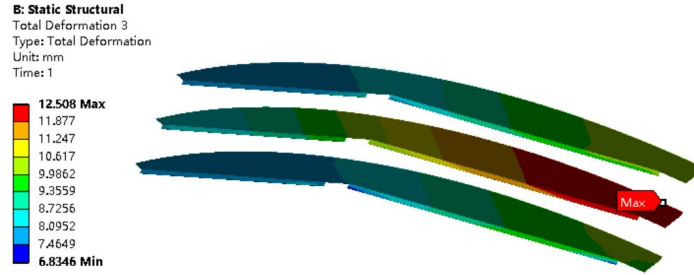

Figure 14 Main beam structural displacement cloud

From Figure 14, the maximum displacement of the secondary beam is 12.5mm, and the maximum displacement occurs at the end of the main beam against the lower part of the panel. The total length of the main beam is 20770mm, and the ratio of deflection to calculated span is about 1/1661, which is much less than 1/750 and meets the design specification.

### 3.4 Structural strength and stiffness checks of the outriggers

The stress cloud of the outrigger is shown in Figure 15 and the displacement cloud is shown in Figure 16. From the stress cloud of the main beam, it can be seen that the maximum stress is 139.9MPa, and the maximum stress is at the attachment between the vertical rod and the horizontal rod of the outrigger, which is less than the allowable stress of the material, so the structural strength of the outrigger meets the requirements of the design specification.

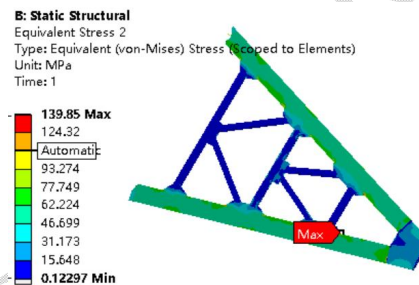

Figure 15 Stress clouds for outriggers

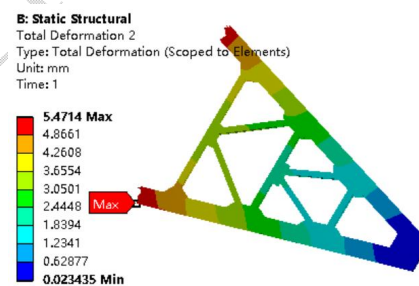

Figure 16 Structural displacement clouds of the outriggers

As can be seen from Figure 16, the maximum displacement of the leg is 5.5mm, the maximum displacement occurs at the connection between the leg and the main beam of the panel, the total length of the leg is 17694mm, the deflection is 1/3210, far less than 1/750, which meets the design specification requirements.

## 4 Analysis of finite element calculation results for seismic conditions

### 4.1 Overall structural strength and stiffness checks

The stress cloud of the arc gate is shown in Fig. 17 and Fig. 18, and the displacement cloud is shown

in Fig. 19. As can be seen from Figure 17, the overall structure of the arc gate is mostly less than 150MPa, less than the material allowable stress of 196.65MPa; as can be seen from Figure 18, the local stress concentration appears in the secondary beam and the panel and the main beam connection position, this position is mainly under pressure under load, the maximum local pressure bearing stress is 280.61MPa, less than the local pressure bearing allowable stress of 299.25 MPa, so the overall structure of the curved gate meets the design specification requirements. Comparison between working condition one (normal working condition) and working condition two (seismic condition) shows that the seismic load has less influence on the maximum stress value of the arc gate, but the location of the maximum stress value is not the same.

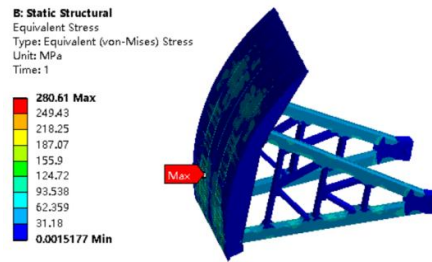

Figure 17 Overall structural stress cloud



Figure 18 Local enlargement of concentrated stress

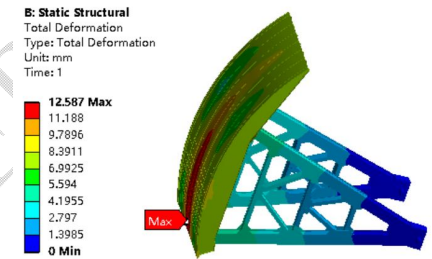

Figure 19 Overall structural displacement cloud

As can be seen from Figure 19, the maximum deformation of the overall structure of the arc gate is 12.6mm, and its deformation distribution trend is larger for the panel position and smaller for the outrigger displacement, mainly because the panel is directly subjected to water pressure and the panel size is larger; at the same time, at the panel, the trend of gradually increasing deformation from the upper to the lower, from both sides to the middle is presented, which is mainly due to the gradual increase of water pressure from the upper to the lower of the panel, and the outrigger support Near both sides of the panel, the middle span of the panel is much larger than the length of the cantilever on both sides, so the displacement calculation structure reviews the actual situation.

#### 4.2 Structural strength and stiffness checks of secondary beams

The stress cloud of the secondary beam is shown in Fig. 20 and Fig. 21, and the displacement cloud is shown in Fig. 22. From the stress cloud of the secondary beam, it can be seen that the X-axis primary stress of the secondary beam is the largest, but the local compressive stress is still less than the allowable local

compressive stress, so the structural strength of the secondary beam meets the design code requirements.

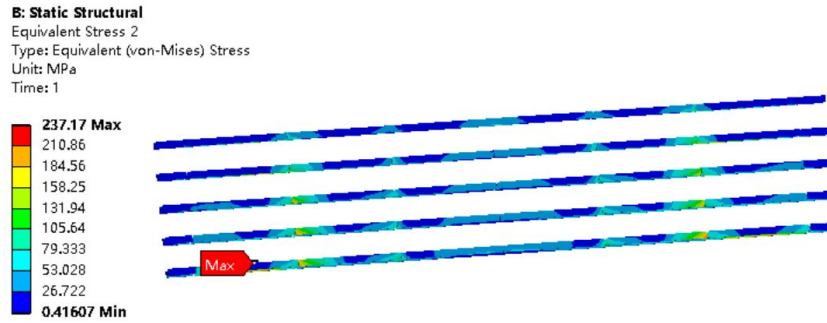

Figure 20 Secondary beam stress cloud

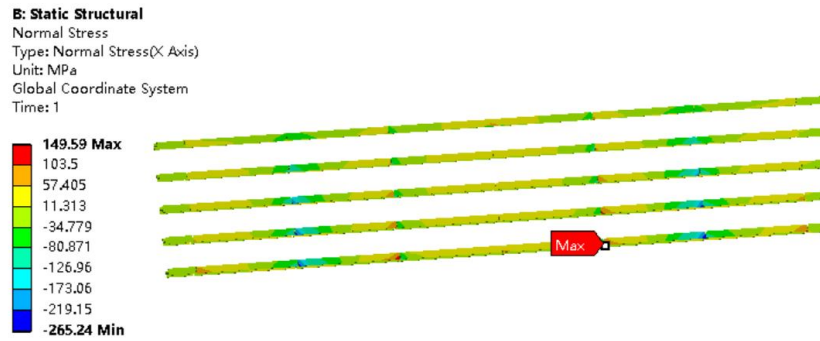

Figure 21 X-axis principal stress

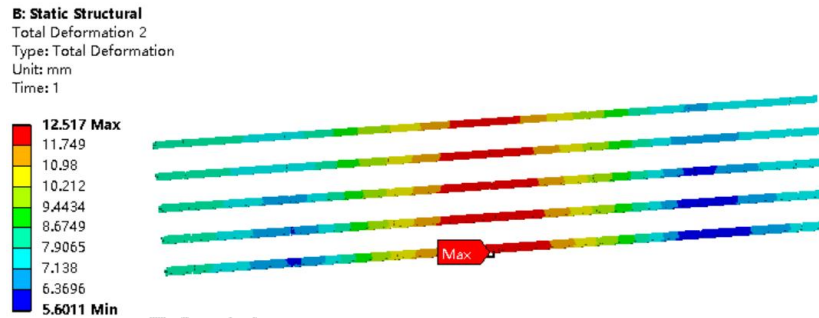

Figure 22 Secondary beam structural displacement cloud

From Figure 22, the maximum displacement of the secondary beam is 12.5mm, the maximum displacement occurs in the middle of the secondary beam, the total length of the secondary beam is 12,762mm, the ratio of deflection to the calculated span is about 1/1021, far less than 1/250, which meets the design code requirements.

#### 4.3 Structural strength and stiffness check of main beam

The stress cloud of the main beam is shown in Figure 23 and the displacement cloud is shown in Figure 24. From the stress cloud of the main beam, it can be seen that the maximum stress is 208.5MPa, and the maximum stress is at the connection between the lower secondary beam and the main beam, but the local compressive stress is still less than the allowable local compressive stress, so the structural strength of the main beam meets the design code requirements.

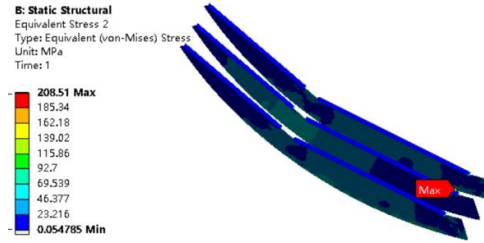

Figure 23 Main beam stress cloud

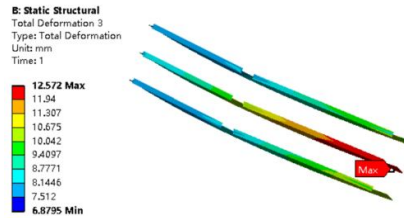

Figure 24 Main beam structural displacement cloud

From Figure 24, the maximum displacement of the secondary beam is 12.6mm, and the maximum displacement occurs at the end of the main beam against the lower part of the panel, the total length of the main beam is 20770mm, and the ratio of deflection to calculated span is about 1/1648, which is much less than 1/750, meeting the design specification.

#### 4.4 Structural strength and stiffness checks of the outriggers

The stress cloud of the outrigger is shown in Figure 25 and the displacement cloud is shown in Figure 26. From Figure 25, the maximum stress is 141.2MPa, the maximum stress is at the attachment of the vertical rod and the horizontal rod of the leg, which is less than the permissible stress of the material, so the structural strength of the leg meets the design specification requirements.

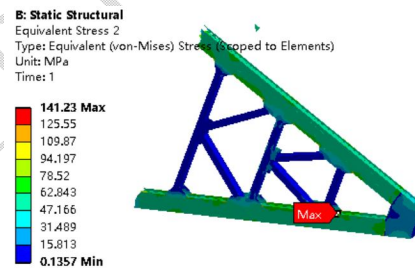

Figure 25 Stress clouds for outriggers

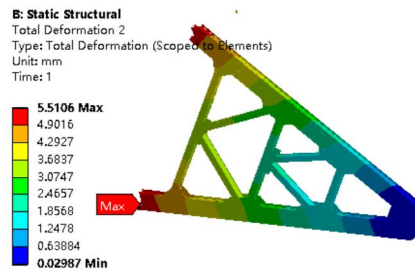

Figure 26 Structural displacement clouds of the outriggers

As can be seen from Figure 26, the maximum displacement of the leg is 5.5mm, the maximum displacement occurs at the connection between the leg and the main beam of the panel,

the total length of the leg is 17694mm, the deflection is 1/3210, much less than 1/750, which meets the design specification requirements.

### 5 Strength check calculations for lifting lugs

In the process of opening and closing the curved gate, the maximum stress value of the lug under the action of the opening and closing force should be guaranteed to be less than the allowable stress, i.e. the strength meets the requirements of the design specification. As can be seen from Figure 27, the maximum stress in the lug is located at the contact position between the shaft and the upper surface of the hole, and the maximum stress is 165.6MPa, which is less than the allowable stress of 196.65MPa and meets the requirements of the design specification.

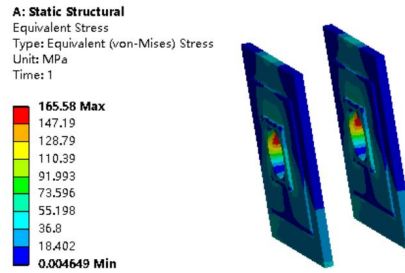

Figure 27 Lifting lug stress cloud

The results of the strength and stiffness checks for each working condition of the spillway table hole working gates are shown in Table 3, and through the previous analysis it can be seen that the strength and stiffness of the spillway table hole working gates meet the requirements of the relevant design specifications.

Table 3 Spillway table hole working gate strength and stiffness calibration results

Working conditions	complex Stress	Stress (MPa)						strain (mm)	results
		Positive Stress			Shear stress				
		X-axis	Y-axis	Z-axis	XY plane	YZ plane	XZ plane		
1 Overall	279.7	-264.3	-253.1	-193.2	-70.4	-87.9	-145.6	12.5	√
Secondary beams	199.9	-226.6	-75.2	-108.7	-46.3	-70.2	-83.9	12.3	√
Main beam	207.8	-42.3	-34.9	-81.9	-56.7	37.2	11.4	12.5	√
Legs	139.9	-32.1	-79.5	-148.6	-26.6	66.2	38.5	5.5	√
2 Overall	280.6	-265.2	-254.6	-193.6	-70.6	-88.3	-146.1	12.6	√
Secondary beams	237.2	-265.2	-75.5	-121.3	67.5	-70.6	-129.5	12.5	√
Main beam	208.5	-42.4	50.9	-82.1	-57.0	37.1	111.8	12.6	√
Legs	141.2	-32.3	-80.1	-150.0	-26.6	66.8	38.8	5.5	√
3 Hanging ears	165.6	-124.0	153.3	-57.6	-83.0	-45.6	-27.6	—	√

### Conclusion

Using the method of finite element analysis after 3D modelling to analyse the strength and stiffness of the hydroelectric power station spillway table hole arc working gate under three working conditions (ordinary working condition, earthquake working condition, opening and closing working condition), the following conclusions were obtained.

---

(1) hydroelectric power station spillway table hole arc work gate in ordinary working condition, earthquake working condition, opening and closing working condition, the stress at all parts of the gate are less than the permissible stress of the material, to meet the design requirements. The deformation of the body is small relative to its size, indicating that the gate structure has sufficient stiffness and meets the design requirements.

(2) After the analysis, it provides effective data support for the design of the structure of the curved working gate of the spillway table hole of the hydropower station, and provides a reliable basis and experience reference for the rapid design and general standardisation of the gate.

(3) Based on the finite element analysis of the strength and stiffness of the hydroelectric power station spillway table hole arc working gate structure, the results obtained can provide reference for engineering practice and structural design, for the stress concentration parts, can be locally strengthened, optimise the structure to improve the service life of the gate.

### References

- [1] Su C C, Wu Z Y, Wang J. Vibration Mitigation Analysis of Steel Radial Gate Based on MTMD System[J]. Yellow River, 2022, 44(08): 132- 135+156.
- [2] Fan C R. Design of hydraulic steel structures [M]. Beijing: China Water & Power Press, 2019.
- [3] XU Z W, Cai W, Zhou J F. Research on Some Problems of Spatial Finite Element Linear Analysis of Plane Steel Gate [J/OL]. China Rural Water and Hydropower:1-12[2023-01-27]. <http://kns.cnki.net/kcms/detail/42.1419.TV.20230113.1059.011.html>.
- [4] Xu X, Li Z K, Zhao M Y, et al. Simulation and Numerical Analysis of Dynamic Operation Characteristics of Miter Gate [J]. Water Resources and Power, 2022, 40(07): 213-216+155. DOI: 10.20040/j.cnki.1000-7709.2022.20212406.
- [5] Li Q, Zheng S Y. Evaluation of Hydraulic Steel Gates Based on Intuitionistic Fuzzy Hierarchy Method and Cloud Model [J]. Yellow River, 2022, 44(03): 118-121+143.
- [6] Cao H Y, Ma R C, Yu J Y. Distribution and transmission of water load between main loading components of arc gate[J]. Yangtze River, 2022, 53(01): 160-166. DOI: 10.16232/j.cnki.1001-4179.2022.01.025.
- [7] GB 51247-2018, Standard for seismic design of hydraulic structures[S].