

Original Research Article

Design and Structure Research of Forklift Seats Based on Ergonomic

Abstract: With the continuous development of the logistics industry, forklift trucks, as essential handling equipment, play an important role. In recent years, the sales volume of forklifts has increased dramatically, and the manufacturers of forklifts have developed more rapidly. Besides having high energy sales, modern forklifts also have to consider safety. The forklift seat is the most contact between the driver and the truck. Road factors cause the vibration of the forklift truck, and the operation process is reduced by the seat, which improves the safety and driving conditions for the driver. Based on ergonomics, this paper analyzes the working environment of the forklift seat, puts forward the design goal of the seat, and extracts the design method to improve the safety and comfort of the forklift seat based on ergonomics theory: the seat comfort position, shape, size and other comprehensive design research. According to the data on adult human body size provided by GB10000-88 and the ergonomics principle of seat design, the relationship between seat parameters and human body size data is studied. A forklift seat size data suitable for the The seat's comfort (H point) position range is calculated using Matlab software. Based on the ergonomics design module of CATIA, this paper evaluates the comfort of the forklift seat, and the results show that each part meets the comfort requirements of the forklift seat. ADAMS/View simplifies the seat frame structure, the shock absorber model is established, the drive is created using the SWEEP function, and the virtual prototype model is established. The related transfer characteristic curves are obtained according to the dynamic simulation of the seat frame with different load weights. The results show that the increase of spring stiffness shows a linear increase. It is shown that increasing the damping coefficient of the spring can effectively enhance vibration reduction. This conclusion is also verified by driving the vibration test of the forklift seat.

Keywords: forklift seat; ergonomics; structural design.

Introduction: Ergonomics is an emerging fringe science. This discipline is to study the law of good and moderate labor and force in the process of production or operation. Ergonomics is called "Human Engineering" in the United States and "Human Factor

Engineering". In Japan, it is called) "Human Engineering" or a European name transliterated as "Ergonomics". The exact definition of "ergonomics" is to take the human-machine-environment system as the fundamental object of research, use the knowledge of physiology, psychology, and other related disciplines according to the conditions and characteristics of people and machines, and rationally allocate human and machine responsibilities. It is a broad discipline that can create a comfortable and safe working environment for people and achieve optimal ergonomics [4]. This discipline is widely used in product design, especially the science of improving the operating environment, to maximize production efficiency by improving operator comfort and reducing driver fatigue. In the design and structural research of the forklift seat, ergonomics is mainly reflected in the following aspects: (i) Reduce the driver's fatigue during operation: the unique design can reduce the vibration transmitted to the driver, and the change is transmitted to the driver by the forklift. The frequency of the seat that is harmful to various parts of the human body; (ii). Comfort: the humanized design can keep the driver in a comfortable mood, and operation errors can be effectively reduced; it provides a good experience for the driver, improving efficiency and ensuring the driver's safety. Applying ergonomics theory: Dou Zhiping from the Environmental Protection Institute of the Mechanical Science Research Institute in "Forklift Design."

Analysis of Ergonomics in Design [6], puts forward the ergonomics requirements in the design of modern forklifts, analyzes the composition of the human-machine system of the forklift, and analyzes the human factors that affect the operation of the forklift from the perspective of ergonomics. The relevant design principles are put forward from a theoretical point of view. When designing forklift seats, Yan Bo's "Application of Ergonomics in Forklift Design" [7] from the School of Mechanical and Electrical Engineering of Hohai University verified the feasibility of the design by establishing a Pro/Engineer digital human model. In addition, ergonomics has been applied in the design and arrangement of vehicles and construction machinery.

In our research work, the main focus is to takes ergonomics as the theoretical basis and mainly studies the application of ergonomics in the design and structure of forklift seats,

as well as the research on the evaluation method of forklift seat comfort to solve the comfort and safety of forklift seats and the question of convenience. The main contents of this article include: (i) Theoretical research on ergonomics of forklift seats. Including the definition, development history, research objects, and research methods of ergonomics; relevant knowledge of anthropometrics involved in the design of forklift seats; related theoretical research on forklift seat design. (ii) The design of the forklift seat. Firstly, the exceptional working environment of the forklift seat is analyzed, the design goals of the seat are proposed, and the design method to improve the safety and comfort of the forklift seat is summarized based on ergonomics theory. Conduct comprehensive design studies. (ii) Using CATIA as a platform in the ergonomic design and analysis module, establish a human body model file that conforms to the size of the Chinese human body and check the rationality of the design of the forklift seat through the generated Chinese three-dimensional human body model. The human vibration test report verifies the comfort of the seat.

Literature Review:Huang Ying and Zhang Yizhen of Northeastern University put the driver at the center in the article "The Application of Ergonomics in the Layout and Design of Construction Machinery Cabs" [8]. They used ergonomics theory to carry out the driver's seat in the cab—research on the arrangement of facilities such as chairs, instrument panels, and operating devices.

Wang Yi and Cui Pingping of Chery Automobile Co., Ltd. stated in the article "Optimized Design of Dynamic Characteristics of Car Seats" [9], 2015 that with the rapid popularization of private cars in my country, people are paying more and more attention to the ride comfort of vehicles. The ride comfort of the vehicle is closely related to the dynamic characteristics of the seat. This paper analyzes and optimizes the critical parameters of the dynamic characteristics of the seat and finds an effective method to improve the dynamic comfort of the seat.

Sun Mingxin from the Tianjin Technology Development Branch of China FAW Co., Ltd. in "Seat Design Based on Ergonomics" [10], 2016 In modern automobile design,

consumers pay more attention to the riding comfort of seats. The difficulty of design has shifted from the product itself to finding the most suitable way and means to connect people and products. The use of ergonomic principles to design modern seats is the inevitable development of seat design, and it is also the primary means to develop seats suitable for human sitting. The article expounds on ergonomics and seat design, respectively, and analyzes the application of ergonomics in seat design. The ergonomic seat design is the trend of future seat design.

Yang Ying et al. of Northeastern University measured the internal dimensions of the construction machinery cab in "Determining the Comprehensive Factor G of the Construction Machinery Cab Size by Factor Analysis" [11], 2016, and used the factor analysis method to analyze the measured values to find out. The total factor G of the cab size is affected by each variable, interface, and score formula. The G value can be used as a theoretical basis for evaluating whether the operating device of the construction machinery cab is comfortable and reasonable.

Methodology: The ergonomics research not only adopts the research methods of related disciplines such as human science and biological science but also adopts some research methods of systems engineering, control theory, statistics, and other disciplines, and also establishes some new methods of this discipline. To explore the complex relationship between human, machine, and environmental elements. Standard research methods are observation, measurement, experimental, simulation, test, Computer numerical simulation, and analysis and research methods. Figure 1 shows the waist curve generated in various postures. The average waist curve of the human body is in a relaxed state. The curve of lying on the side, as shown by curve B in the figure; the lumbar curve when the trunk is upright sitting and forward bending will seriously deform the lumbar spine, as

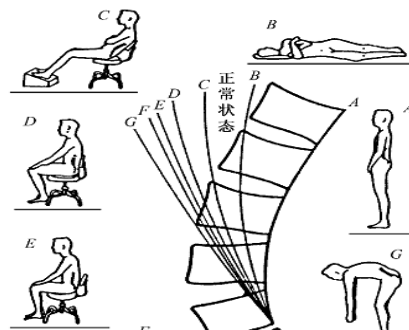

shown by curves F and G in the figure; if the sitting posture can form an almost normal for the waist curve, there must be an angle greater than 90° between the torso and the thigh. There must be support at the waist, as shown by curve C in the figure. It can be seen that ensuring the normal shape of the waist curve is the key to obtaining a comfortable sitting posture. It can be seen from Figure 2 that the pressure of the human body weight on the seat is not evenly distributed. The above ergonomic analysis shows that in a comfortable sitting position, the body weight is supported by the shoulders and buttocks, so it should be based on the human body.

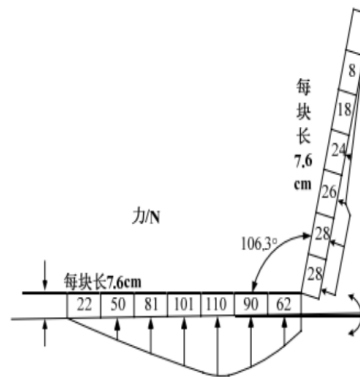

Figure 2: Reasonable distribution of forces on each part of the seat [27]

Dynamic Model of Forklift Seat

Currently, many researchers have established mathematical models of forklift seats with the help of computers. In the model, considering the human body's comfort, the vibration frequency of 4-8 Hz should be effectively avoided. If it is within this range, its frequencies will cause unavoidable damage to the human body.

Research on the dynamic performance of the forklift seat: According to the design requirements, a human-seat single-degree-of-freedom dynamic model is established. According to this system, the research on the seat's comfort can be realized, and it is convenient to conduct research according to different situations. The focus of the model is that when the vibration caused by the ground imbalance is transmitted to the seat in the vertical direction, its dynamic model can be roughly simplified as follows: The

human body and the seat are abstracted into rigid bodies, and their mass is M , whichever is the stiffness coefficient is K , and the damping is C . Through the experimental analysis, the vibration response peak of the seat obtained by replacing the driver with a rigid body is higher than that in the actual driver's driving process. The main reason is that the human body is not simply regarded as rigid but also has a specific damping. The actual driver's vibration response peak is lower through the effect of damping and the effect of the seat back. This gap has a significant impact on the seat optimization process.

Ergonomics requirements in the comfort design of forklift seats

Seats with different design structures directly affect the operating comfort of forklift drivers. The unreasonable structure will directly cause the forklift driver to have an incorrect sitting posture, which will put the driver's spine in an unnatural bending state, making the forklift driver prone to various chronic diseases. Based on the crucial role of ergonomics in seat design, the body pressure distribution of the resultant force, the normal physiological curvature of the spine, and the resistance to lateral vibration should be considered in the seat design process [28].

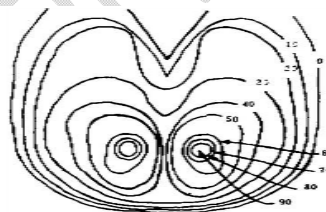

Figure 3: The human body pressure distribution curve of the seat cushion

In Figure 3 (the closed curve is an isobaric line, and the numerical pressure is 102Pa). This ideal seat cushion structure is essential for seat vibration comfort and cushion. The soft and hard feeling between the backrest and the backrest plays an important role [29]. The angle between the seat cushion of the human body and the horizontal direction can make the pressure concentrated around the ischial tuberosity at the back of the thigh. Generally, the angle can be taken as $5 \sim 10^\circ$. Good design of the angle size can prevent the hips from sliding forward, as well as physical and psychological fatigue.

The ergonomics theory shows that the human body's lumbar spine needs to bear the total weight of the upper part of the body and the impact load generated by the vibration of the forklift. Figure 4 below shows the structure of the vertebrae and discs.



Figure 4: Structure diagram of vertebrae and intervertebral discs

As shown in Figure 4, vertebrae are bones with muscles and ligaments that protect the spinal cord. Continuous vertebrae and vertebral foramen form the spinal canal. The spinal cord flows within the spinal canal. An intervertebral disc is a disc of elastic cartilage between two adjacent vertebrae. Figure 5 below shows the muscles that enable movement in the spine.



Figure 5: Schematic diagram of the muscles that enable the spine to function

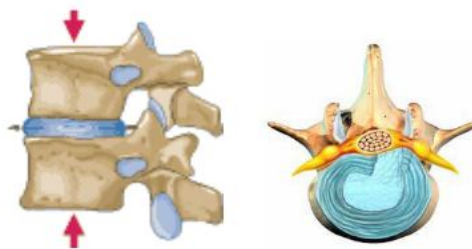

Figure 6: Schematic diagram of intervertebral disc force and compression of spinal nerve endings.

In figure 6, we show that according to the compression potential and elasticity of the intervertebral disc, the spine can withstand solid longitudinal vibration. However, the

lateral force of the human spine in the lateral direction is relatively low. The backrest of the seat back can make the lumbar back, and the back cushion is moderately soft, resulting in a large friction force [30].

Ergonomic Design of Forklift Seats

With the development of the economy and the advancement of technology, the utilization rate of forklifts has continuously increased. Based on meeting the performance requirements, people have higher and higher requirements for the comfort of forklifts. Forklift seat comfort is an integral part of the design. The forklift driver's driving posture directly affects the driver's comfort and health and is related to whether the driver can drive safely, efficiently, and accurately.

Objectives of Forklift Seats

Taking the ergonomics theory as the starting point, combined with the working environment of the forklift seat, a forklift seat with good performance should have the following basic requirements: (i) Provide a stable and comfortable sitting posture for the driver, which should meet the requirements of the physiological characteristics of the comfortable sitting posture of the human body; (ii) Reduce the mechanical vibration and impact load transmitted to the driver's body and meet the requirements of the vibration comfort evaluation standard; (iii) Place the driver in a position with a good field of vision to ensure that he can safely and effectively complete various manipulation operations; (iv) Provide the driver a suitable position relative to the various operating mechanisms so they can be easily operated.

Result and Discussion: When designing the seat's comfort, first of all, the position of the seat in the forklift cab must be determined. The determined position must ensure that the joints of the driver are within the comfortable angle of the human body during the operation. The human body H-point (i.e., the span point) is a crucial reference point when determining seat position. The H point is the junction of the human torso and the thigh and is used as a reference point for body dimensions related to sitting comfort. After the driver adjusts the seat to a comfortable position according to his conditions, the

relationship between the horizontal movement amount and the vertical movement amount at the H point reflects the relationship between the front and rear movement amount and the vertical movement amount of the seat. Reasonable arrangement of the seat position and improvement of the relationship between the driver and the seat plays an essential role in giving the driver a comfortable and safe working environment. To ensure a comfortable sitting posture of the human body, we must first ensure the comfort of the H point, so we need to study the comfort range of the H point. The commonly used calculation method of the H point is given by SAE J1517 [30], which is derived by Philippartal using the regression formula and is used for calculating the seat position of the seven percentiles. In the experiment, let the driver choose a suitable driving position, write down the position parameters, and calculate a large number of parameters through regression to obtain the appropriate seat calculation formula for the seven percentiles:

$$\{\chi_{97.5} = 936.6 + 0.613879z - 0.00186247z^2\} \quad \{\chi_{95} = 913.7 + 0.672316z - 0.00195530z^2\} \quad \{\chi_{90} = 885.0 + 0.73z - 0.00195530z^2\}$$

Among them, Z represents the distance between the heel point of the pedal and the H point, mm; xi Indicates the horizontal distance between the rear of the reference point of the heel and heel point of its percentile driver and the point H, mm.

Formula (4-1) can be used as a reference for evaluating the seat position and vertical and horizontal adjustment. At the same time, the SAE standard stipulates that 87° is the comfort angle of the ankle joint, according to the mathematical relationship between the height of the seat H point and x, taking the position of H point as the objective function, a set of curves of comfortable sitting position can be obtained.

However, the SAE standard is based on European anthropometric data, and the relationship obtained from these data does not match the anthropometric data in my country. It cannot be directly quoted when calculating the forklift seat H. Therefore, in order to accurately obtain the comfortable position of the H point, it is necessary to establish a human body sitting posture model and mathematical model suitable for China based on the Chinese anthropometric data and set the constraint as the comfortable range of motion angles of each joint of the human body. The data processing software draws

the comfort zone of the corresponding seat H point and provides a theoretical basis for the positional arrangement of the forklift seat. Figure 4-2 shows the H-point model and the dimensions of each part of the human body when the human body is in a comfortable sitting posture, and the comfortable angle range of human joints is shown in Table 1.

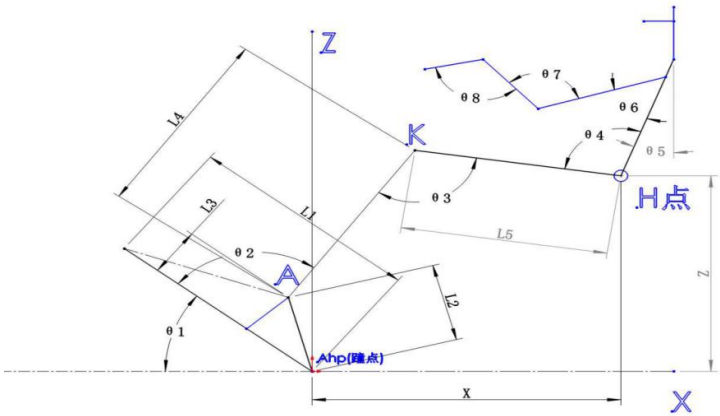

Figure 7: Human body H-point calculation model

Tab.1 Comfortable angle of body joints

Relevant comfort angle value range Relevant comfort angle value range

add Speed pedal and forklift floor (θ_1) $40^\circ \sim 70^\circ$ Upper arm axis and vertical line (θ_6) $10^\circ \sim 45^\circ$

The axis of the calf and the accelerator pedal (θ_2) $85^\circ \sim 110^\circ$ upper arm axis and forearm axis (θ_7) $80^\circ \sim 120^\circ$

thigh axis and calf axis (θ_3) $95^\circ \sim 135^\circ$ between the axis of the forearm and the center line of the hand (θ_8) $170^\circ \sim 190^\circ$

Trunk axis and thigh axis (θ_4) $90^\circ \sim 115^\circ$ thigh axis and horizontal axis (θ_9) $2^\circ \sim 12^\circ$

Torso axis and vertical line (θ_5) $10^\circ \sim 30^\circ$

Table 2: Human size data for H-point calculation

Tab.2 The human dimension used for H calculation

Mannequin Size Name Female 5% Female 50% Male 50% Male 95%

Distance from heel to toe (L1) 193.5 204.2 215.0 225.0

Distance from the ankle joint to heel point (L2) 117.0 123.5 130.0 136.5

Distance from the ankle joint to accelerator pedal plane (L3) 90.0 95.0 100.0 105.0

Calf Length (L4) 350.0 375.0 395.0 425.0

Thigh length (L5) 350.0 373.0 406.0 433.0

1. Establish a mathematical model - H point in a comfortable sitting position X and Z represent the coordinate position of point H and are shown in the figure, where the origin is the heel point, which is calculated from Figure 4-1 X=X' Expression for the position of the H point:

$$\left\{ X = L_5 \cos(\theta_9) + L_4 \cos(180^\circ - \theta_1 - \theta_2) + L_3 \cos(90^\circ - \theta_1) - \sqrt{L_2^2 - L_3^2} \cos(\theta_1) \right\} \text{ or}$$

$$\left\{ X' = L_5 \cos(\theta_9) + L_4 \sin(\theta_3 + \theta_9 - 90^\circ) + L_3 \cos(90^\circ - \theta_1) - \sqrt{L_2^2 - L_3^2} \cos(\theta_1) \right\} \text{ It can}$$

be seen from equations (4.2) and (4.3) that the angle between the position of point H and the comfort of the human body $\theta_1, \theta_2, \theta_3, \theta_9$ related. That is to say, the comfortable angle of the human body must satisfy the above two formulas at the same time. $X=X', Z=Z'$, so you can get:

$$\theta_1 + \theta_2 = \theta_3 + \theta_9 \quad (4-4)$$

Where formula (4-4) is the constraint condition, and the inequality $125^\circ \leq \theta_1 + \theta_2 \leq 180^\circ$ and $97^\circ \leq \theta_3 + \theta_9 \leq 167^\circ$ established, it is known that

$$125^\circ \leq \theta_1 + \theta_2 = \theta_3 + \theta_9 \leq 167^\circ \quad (4-5)$$

and $\theta_1, \theta_2, \theta_3, \theta_9$ All are within the comfortable angle range. According to formulas (4-2) or (4-3) and (4-5), using Matlab software, the H point position of any comfortable sitting posture can be obtained.

According to the above mathematical model, we use Matlab software to solve to calculate the area range of the H point position of any comfortable sitting posture. Its primary function is to find the front and rear end points of the H point in a comfortable sitting position to obtain the horizontal movement of the seat; the highest and lowest end points of the H point to obtain the vertical movement of the seat; and the H point area range. Here we select the body size data of 5% of women, when $\theta_9 = 3^\circ$ hour, $\theta_1, \theta_2, \theta_3$ Within its comfortable angle range, a set of curves at point H can be obtained, and the same $\theta_9 = 5^\circ$, another set of curves is obtained. Figure 3-2 is θ_9 Take the H-point curve obtained at $3^\circ, 5^\circ, 7^\circ$, and 11° .

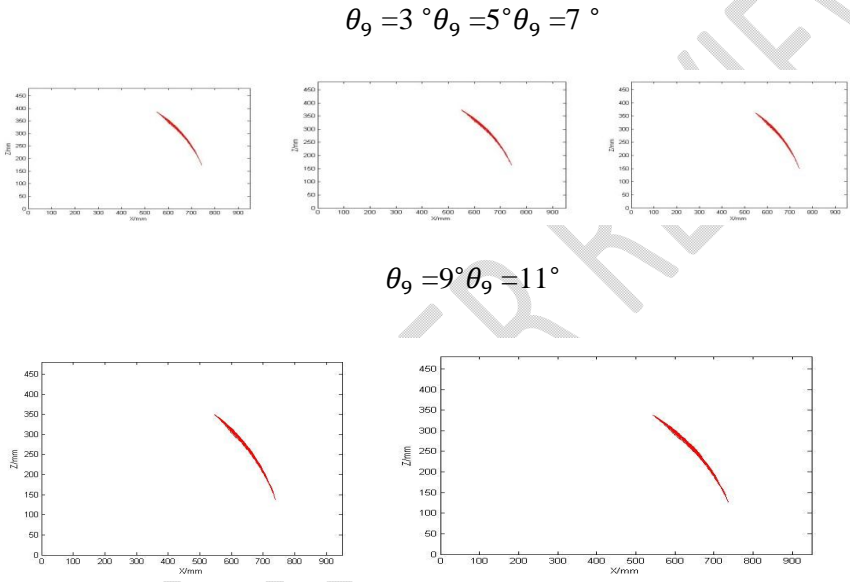

Figure 8: Variation range of 5% female H point

Figure 8 is θ_9 Five sets of graphs for the position of the H-point in a comfortable sitting position for 5% of women within its variation range.

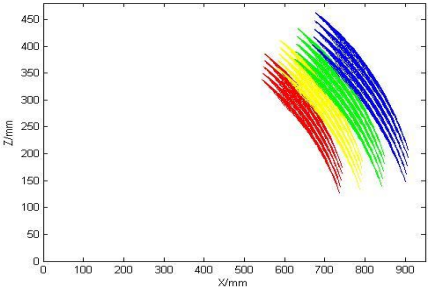

Figure 9: H point position curve (5% females comfortable in sitting position)

In the same way, we get the position change area map of point H in the comfortable sitting position for 5% women, 50% women, 50% men, and 95% men, as shown in Figure 10.

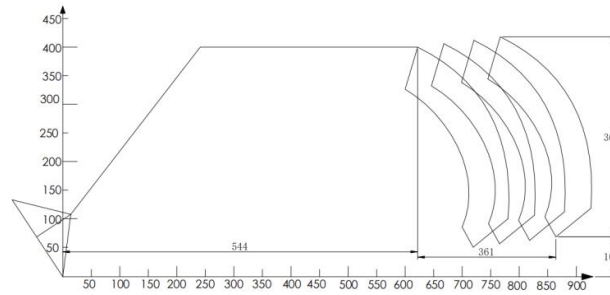

Figure 10: H-point comfortable sitting area map (different human body percentiles)

As seen from the above figure, the factors affecting the range of the H-point area under the comfortable sitting posture are the human comfort angle and the percentile. In the area of 95% men and 5% women, the horizontal movement of the H point in a comfortable sitting position is 361mm, and the vertical movement is 364mm. This value is suitable for 90% of the human body. This range of values can be used as a reference for seat adjustment. The horizontal adjustment is generally taken as 160mm in the conventional design.

Evaluation of Forklift Seat Comfort Based on CATIA

CATIA (Computer-aided Three-dimensional Interactive Application, computer-aided three-dimensional interactive application) is a CAD/CAE/CAM integrated software of French Dassault Company, widely used in aerospace, automobile manufacturing, shipbuilding, machinery manufacturing, electronics, electrical appliances, etc.

CATIA's ergonomics design module is an object-oriented system that combines ergonomics with design modules, enabling designers to design ergonomics easily. Using CATIA software as a platform, it can vividly simulate various operating states and motion postures of people in real life, thereby helping designers to design parameters in various human-machine aspects [38]. After establishing the preferred angle of the human

body model, you can enter the analysis stage of the posture through the evaluation of the human body posture. Generate analysis reports using estimation analysis tools. The analysis report has two display modes: list and chart. The score of the evaluation result is expressed as a percentage, which is used to measure the comfort of the posture. The higher the score, the more comfortable it is. Figure 11 is an evaluation report generated from the preferred angle.

Segments	Side	Result (%)
All (all DOF)		91.3
All		91.3
Selected		91.5
Favorite		
Other		
Thigh	L	84.5
	R	97.1
Leg	L	91.5
	R	90.1
Arm	L	86.4
	R	95.6
Forearm	L	100.0
	R	84.8

Figure 11: Postural score analysis

ADAMS Software Modules

ADAMS is divided into five modules: (1) core module; (2) functional expansion module; (3) professional module; (4) interface module; (5) toolbox. The core modules include ADAMS/View (user interface module), ADAMS/Postprocessors (dedicated post-processing module), ADAMS/Solver (solver), etc.; functional expansion modules include ADAMS/Durability (durability analysis module), ADAMS/Insight (Experimental design and analysis module), ADAMS/Hydraulics (hydraulic system analysis module), ADAMS/Vibration (vibration analysis module), ADAMS/DMU Replay (digital assembly playback module), ADAMS/Animation (high-speed animation module), ADAMS/Linear (System modal analysis module), ADAMS/Auto Flex (general flexible body automatic generator), etc.; professional modules include ADAMS/Car Package (car design software package), ADAMS/Engine Package (engine design software package), ADAMS/Tire Package (tire module package), EDM (experimental dynamics module), ADAMS/FBG (dedicated flexible body automatic generator), ADAMS/Figure (human body module), etc.; interface modules include ADAMS/Exchange (graphic interface module), CAT/ADAMS (CATIA professional interface module), MECHANISM/Pro (Pro/E interface), ADAMS/Flex (flexible analysis

module), ADAMS/Controls (extension module), etc. The toolbox includes ADAMS/Virtual Test Lab (virtual test toolbox), Modal Stress Recovery and Fatigue, Tracked/Wheel Vehicle, ADAMS/Gear Tool, ADAMS/SDK (Software Development Kit), ADAMS /Truck Toolkit, ADAMS/Motorcycle Toolkit, etc.

Establishment of Dynamic Simulation Model of Forklift Seat Multibody System

In our paper, the multibody system dynamics simulation is carried out for the company's forklift, the SolidWorks three-dimensional model is established based on the company's actual forklift seat, and ADAMS/View establishes the virtual prototype for dynamic simulation.

SolidWorks builds a 3D model of a forklift seat

Figure 12 shows the physical model of the company's forklift seat frame. According to the design drawings, SolidWorks is used to create a three-dimensional model of the forklift seat frame, and interference detection is performed to confirm that the model is correct, as shown in Figure 13. Save the 3D model of the forklift seat frame established by SolidWorks as an "x_t" format file, and import the 3D model into ADAMS through ADAMS/Exchange (interface module).



Figure 12: Forklift Seat Frame

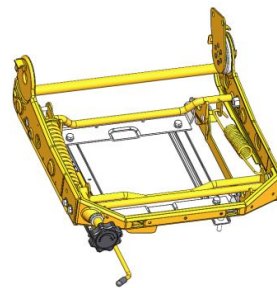

Figure 13: 3D View of Forklift Seat Frame

Create a virtual prototype

To establish a virtual prototype, it is necessary to simplify the 3D model imported into ADAMS/View without affecting the simulation. Parts such as bolts, nuts, washers,

bearings, knobs, seat frames, and external connections are removed. The simplified model is shown in Figure 5. -5 shown. Corresponding to the material of the real parts, the material properties of each part of the virtual prototype are established, and each constraint condition is established at the connection of each part, as shown in Figure 14-15.

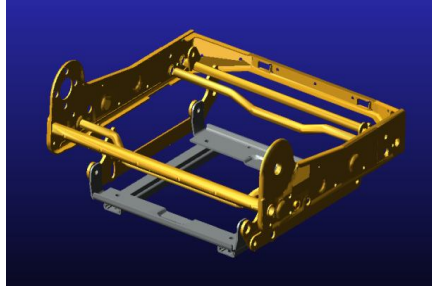

Figure 14: Simplified model of the forklift seat frame

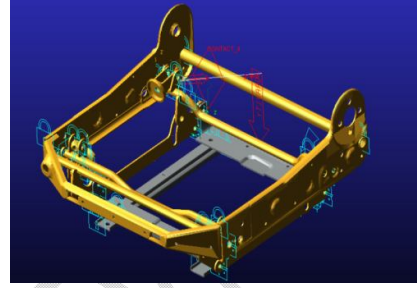

Figure 15: Constraint diagram of the virtual prototype

Establishment of loads and shock absorbers

When the seat dynamics simulation is performed, it is required that the seat is in the condition of carrying people. Therefore, it is necessary to establish the gravity model of the carried object on the dynamic simulation model [46]. To simplify the model, the sphere's mass is set to 50 kg as the character model. As shown in Figure 14-15. Determine the shock absorber stiffness and damping coefficient according to the data to establish a shock absorber model, as shown in Figure 16-17.

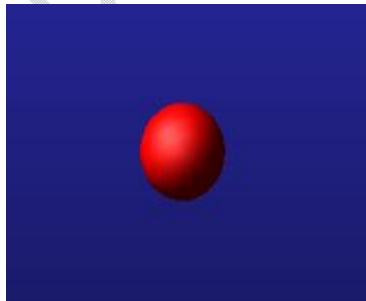

Figure 16: Simplified character model

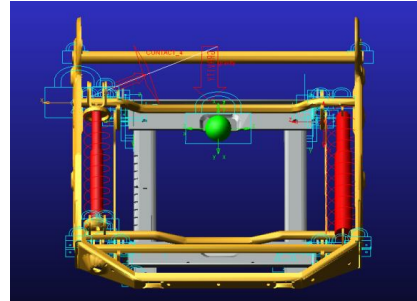

Figure 17: Shock absorber model

Establishing vibration input

In the simulation process, the sine curve scan of the vibration condition of the floor at the driving position is 0-20Hz, which is realized by the SWEEP function in the ADAMS software function library. The function format is:

SWEEP (Independent Variable, Amplitude, Start Value, Start Frequency, End Value, End Frequency, Delta X)

In the formula: Independent Variable——independent variable;

Amplitude——Amplitude;

Start Value - the initial value of the argument;

Start Frequency - initial frequency;

End Value - the end value of the argument;

End Frequency - end frequency;

Delta X - the step size of the independent variable.

According to the simulation requirements: SWEEP (time, 5.0, 0.0, 0.1, 20.0, 20.0, 1.0E-002). It is a function of the simulated input signal, and the output signal obtained after the simulation is a time-domain signal. After the FFT transformation of the time-domain signal, a frequency-domain signal is obtained. The displacement curve of the excitation function and the Fourier transform curve is shown in Figure 5-9., as shown in Figure 18-20: Shows the displacement curve of the carried object and its Fourier transform curve are shown in Figures 19-21-.

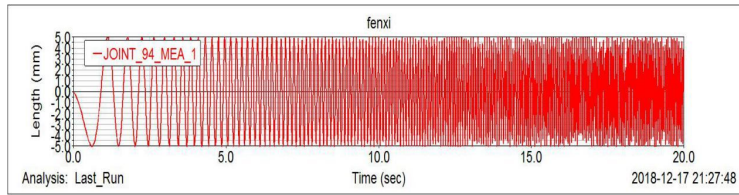

Figure 18: Displacement curve of the excitation function

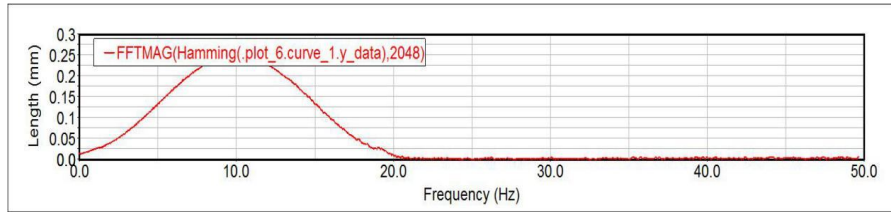

Figure 19: Fourier transform curve

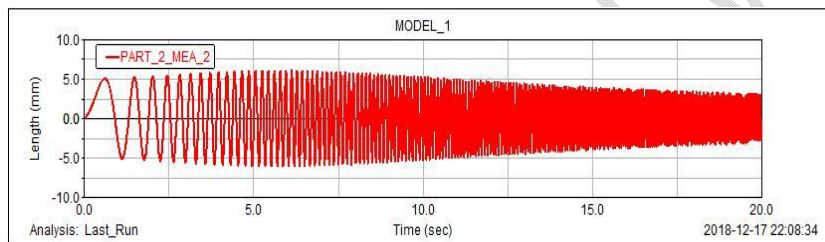

Figure 20: Load displacement curve

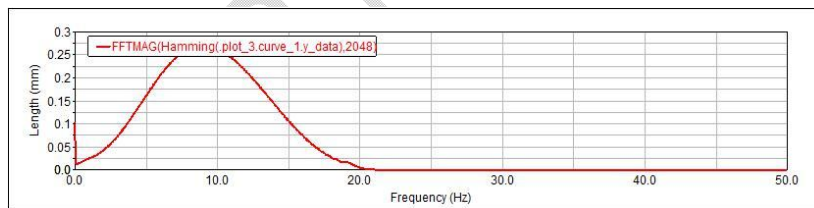

Figure 21: The Fourier transform curve of the cargo

Analysis of Simulation Results

According to the virtual seat prototype established by the above modelling, the simulation analysis was carried out when the load weight was 50kg, 60kg, 70kg, and 80kg. The characteristic transfer curves of the seat were obtained as shown in Figures 22, 23, and 24, as shown in Figures 25.

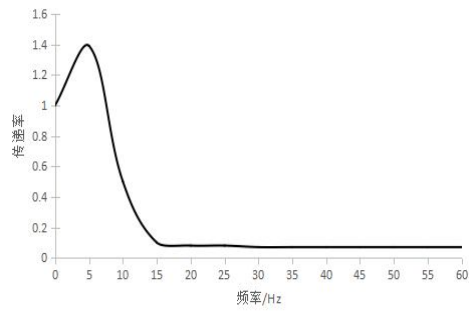

Figure 22: The Fourier transform curve of the cargo

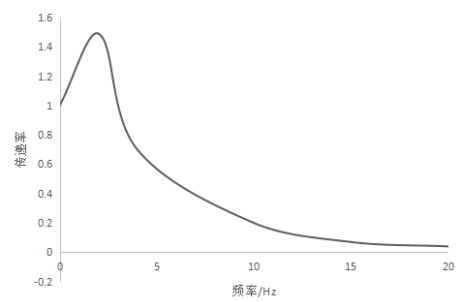

Figure 24: Simulation transfer characteristic curve of 70kg payload

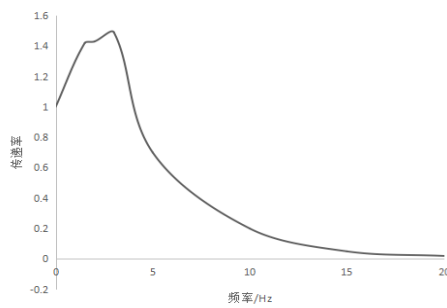

Figure 23: Simulation transfer characteristic curve of 60kg payload

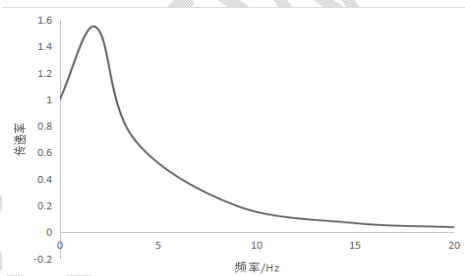

Figure 25: Simulation transfer characteristic curve of 80kg payload

By comparing the transfer characteristic curve of the seat obtained by simulation and the obtained sets of transfer characteristic curve data, it can be seen that there is a slight change in shock absorption with the increase of mass, which proves the shock absorption performance of the seat. Ultimately, we evaluate the design through CATIA's Ergonomic

Conclusion: The subject analyzes and compares the current situation of forklift seat design in China and abroad and analyzes and design of forklift seats based on the ergonomics theory to solve the problems of safety, comfort, convenience, and efficiency in the use of forklifts. In our paper, we achieved the following results: (i) Theoretical research on ergonomics of forklift seats, including the meaning, development, and research of ergonomicsresearch content and research

methods, relevant knowledge of anthropometrics involved in forklift design, and relevant theoretical research on forklift seat design. (ii) Based on ergonomics, the seat's comfort is studied from vibration, static, and operation comfort. Based on ergonomics theory, specific requirements for seat comfort are put forward. Namely, it mainly analyzes the posture of the human body, the seat's shape, and the distribution of body pressure. (iii) Theoretical design of forklift seat. The working environment of the forklift seat is analyzed, the design goal of the seat is proposed, and the design method to improve the safety and comfort of the forklift seat is extracted based on ergonomics theory. A comprehensive design study is carried out. The seat is comfortable (H point) position range was calculated using Matlab software. (iv) Based on the ergonomic design module of CATIA, a human body model that conforms to the Chinese human body size is established, and the comfort of the forklift seat is evaluated. The results show that all parts meet the comfort requirements of the forklift seat. Use ADAMS/View to simplify the structure of the seat frame, build the shock absorber model, and use the SWEEP function to create the driver to build a complete virtual prototype model. Through the dynamic simulation of the seat frame for different loading weights, it is obtained that the relevant transfer characteristic curve will increase linearly with the increase of the spring stiffness, and the transfer will decrease with the damping coefficient. The damping coefficient of the large spring can effectively enhance vibration reduction. The vibration test of the forklift seat verifies the correctness of the seat design size and theoretical parameters.

Future Work: From the ergonomics perspective, this paper analyzes the seat and structure of the forklift and makes the corresponding design. There is domestic research on applying ergonomics in the design of forklift seats, and it is not easy to obtain more. Therefore, the research results need to be further supplemented and improved. Based on our paper, the following research work can be carried out: (i) the anthropometric data in this article are based on GB10000-88. This standard has not been updated for more than 30 years. With the improvement of people's living standards, people's physical conditions have also changed. The data in this standard

can no longer be used. To accurately reflect the current physical conditions of people, the data in it needs to be revised and updated promptly. (ii) Conduct a more in-depth study of ergonomic theories used in forklift seat design to form the ergonomic theory system for designing forklift seats, making ergonomics better for researching and developing forklift seats. (ii) The ergonomics theory can be applied to the design of the forklift display device, appearance, vision, etc. so that ergonomics can be more widely used in the design of the forklift seat

UNDER PEER REVIEW

References

- [1] Cao Guiyin, Zheng Xiaofen. Modern Logistics Management [M]. Hefei: University of Science and Technology of China Press, 2013 8-10.
- [2] Yang Zhong. Discussion on the current situation and development of my country's logistics industry [J]. China's new technology and new products, 2010,1.
- [3] Huang Mingshan. Research on the industrial design of forklift seats [D]. Hefei University of Technology, 2009.
- [4] Ding Yulan. Ergonomics [M]. Beijing: Beijing Institute of Technology Press, 2017.
- [5] Yan Bo. Research on the application of ergonomics in forklift design [J]. Mechanical Design and Manufacture, 2007(12):40-41.
- [6] Huang Ying, Zhang Yichen. Applying ergonomics in the layout and design of construction machinery cab [J]. Mechanical Design and Manufacturing, 2000(06):88-89.
- [7] Wang Yi, Cui Pingping. Optimal design of dynamic characteristics of car seats [J]. Automotive Practical Technology, 2017(17):63-64.
- [8] Sun Mingxin. Seat design based on ergonomics [J]. Automotive Engineer, 2018(07):23-25+36.
- [9] Duan Yaqin. Ergonomics [M]. Wuhan: Wuhan University Press, 2015.
- [10] Shao Shuijin. Human Anatomy- (The Fourth Edition of the New Century) [R]. Beijing: China Traditional Chinese Medicine Press, 2016.
- [11] Yang Bo. Research on personalized interior modification design of family cars based on computer-aided ergonomics[D]. South China University of Technology,2016.
- [12]Gao Ruitao, Wang Yang, Yang Zhou, Jin Hong, Shan Jian. Research progress of tractor seat comfort and vibration damping suspension design[J]. Mechanical

Design,2018,35(08):99-105

[13] Ning Donghong, Jia Zhijuan, Dong Mingming, Du Haiping. Research progress of vehicle seat suspension vibration reduction system[J]. Journal of China Jiliang University,2018,29(02):113-120.

[14] Zhang Lianying. Automobile seat vibration control and simulation analysis[D]. Qingdao University,2018.

[15] Tu Weiwei. Research on Modal Analysis of a Passenger Car Seat[D]. Changsha University of Science and Technology,2017.

[16] Ma Bo. Parametric design of car ergonomics based on CATIA [D]. Beijing Institute of Technology, 2016.

[17] Zhao Yong, Ju Yongfeng. Human Pose Estimation Based on Conditional Prior Human Model [J] Computer Engineering and Applications., 2018,54(16):24-29.

[18] Zhang Qingbin, Ge Jianjian, Zou Wen, Feng Zhiwei.A Case Teaching Research on Multibody System Dynamics[J]. University Education,2018(09):74-76.

[19] Cheng Weihua. Application of multi-rigid body dynamics simulation technology in automobile design[J]. Times Agricultural Machinery,2016,43(04):45-46+52.

[20] Zeng Zhixiang, Liu Xin, Geng Yunxiang, Wang Zhiheng, Zhang Xiao.Research on the modeling method of vertical looper system based on ADAMS[J]. Manufacturing Automation,2018,40(08):98-99+121.

[21] Gao Peng, Han Yingqiang, Ma Tao. Research on the application of virtual prototype technology in the design and manufacture of loader[J]. Internal Combustion Engine and Parts, 2018(11):201.

[22] Chen Pingliang.Dynamic characteristics and control of air suspension[D]. Shenyang University of Technology,2017.

[23] Gao Jing Xuan, Tian Hangzhou, Liang Changjia, Zhang Yi. Research on Vibration Simulation of a Counterbalanced Forklift[J]. Intelligent Manufacturing,2018(04):23-25.

Appendix A

UNDER PEER REVIEW

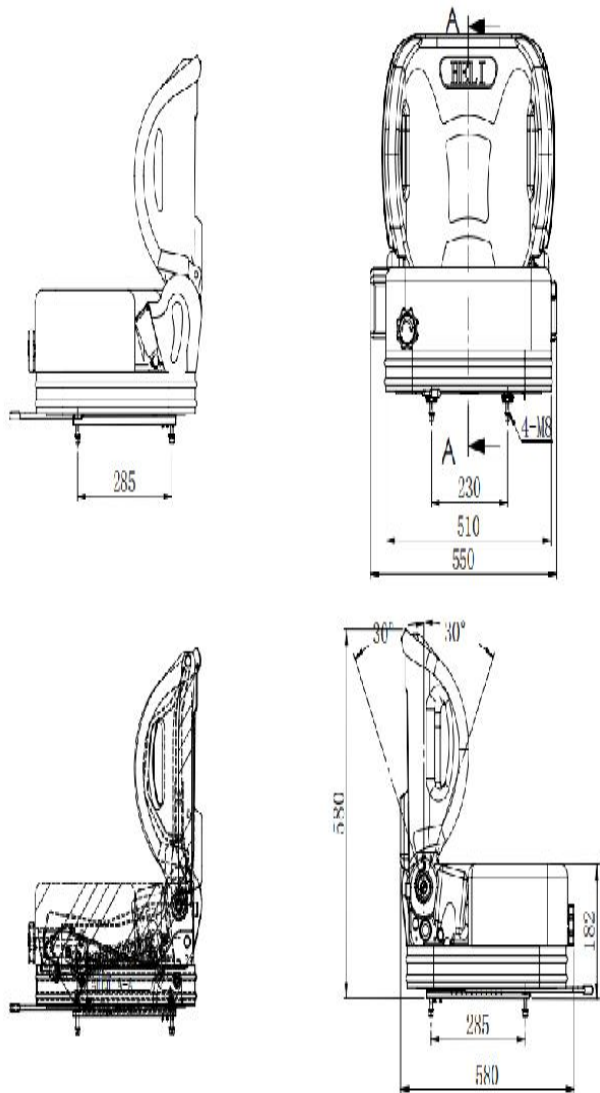

设计		曹洪化				版次	重量	比例
校对							13.1kg	
审核						共 1 张	第 1 张	
工艺		批准						

UNDER PEER REVIEW