

“Design and Fabrication of Portable Motor-Operated Tiller Machine”

Abstract

Agriculture has been an integral part of the human ecosystem. However, traditional farming methods require a lot of human effort and are very time-consuming. Farm tilling is one of the most labor intensive operations in agriculture. Manual tiling of fields is very strenuous task while tractors incur high capital along with heavy fuel consumption costs. This low-cost portable motor-operated tiller machine is a one-stop modern solution to enhance the conventional agriculture methods of farming, as it reduces the human effort, at a very negligible price using motorized tilling mechanism. The electric power tiller helps reduce the time and cost involved in tilling using a smart portable design thereby increasing the productivity and efficiency in agriculture.

KEYWORDS: *Tillage, Portable motor-operated tiller machine, Efficiency, Labour intensive, etc.*

1. Introduction

Tillage is an important agricultural unit operation. A tiller is used for all the intercultural operations performed in the field, among which portable motor-operated tiller machines are mostly used nowadays, and is also one of the most important intercultural machines for smaller marginal agricultural fields or crop farmers. It is also a more economical machine as compared to other manual or mechanical portable motor-operated tiller machines. Battery energy is one of the easiest and most affordable forms of electric energy for farmers to adopt for their operations. According to the time-consuming, laborious, high-costing traditional design methods for the Inter cultivator. The portable motor-operated tiller machine has the problem of pollution and excess vibration. To overcome these issues, the portable motor-operated tiller machine is to be converted to an electrically operated system. So here, the existing gasoline engine is replaced with a motor for drive and batteries for the power source. Battery energy is one of the easiest and most affordable forms of electric energy for farmers to adopt for their operations. According to the time-consuming, laborious, high-coating traditional design methods for the Inter cultivator, in this, we studied the main components of a battery-operated portable motor-operated tiller machine and obtained performance parameters after analysis and simulation work based on modern design methods and tools, the finite element method, and virtual prototyping. It is the best solution for tillage operations for small and medium-sized farms.

2. OBJECTIVE

1. To perform design of motor-operated tiller machine for field conditions.

2. To perform standard analysis of different working parameters for same operating conditions
3. Comparison between working model and other active machines in present.

3. METHODOLOGY

Following is the methodology used to design and fabricate our portable electric tiller and cutter machine.

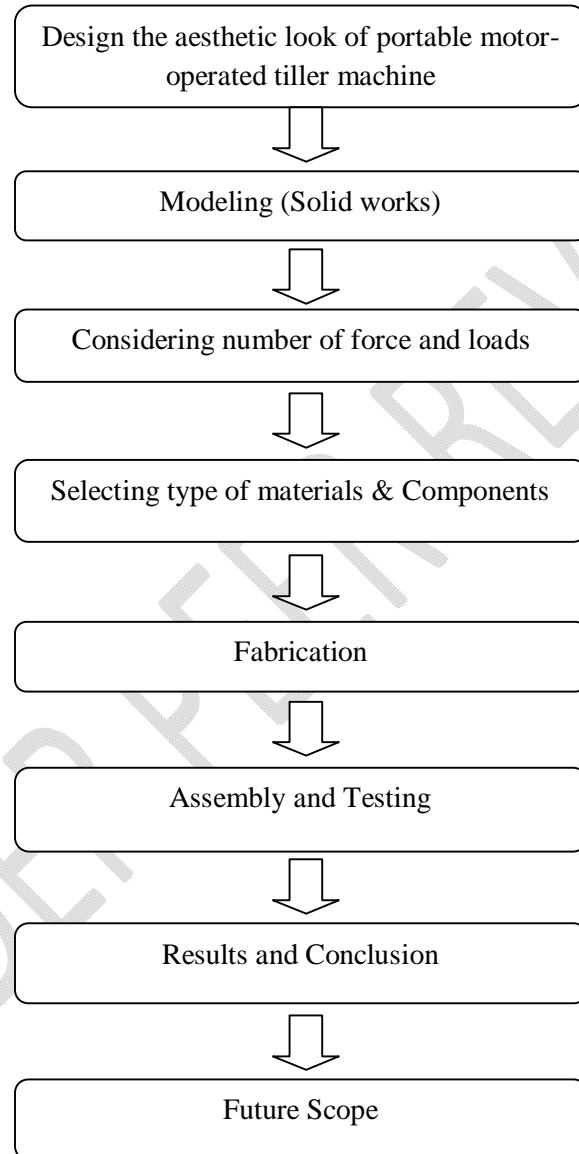

Fig.1 Flow chart

3.1 Material Selection

After doing research on the several material properties, the most feasible material is selected for the portable motor-operated tiller machine. We investigated for the characteristics which are taken into account, which including machine ability, durability, strength, weight,

availability, and material cost. A material with sufficient strength is chosen to ensure that the frame of the portable motor operated tiller machine does not fail under the strain exerted. Rectangular iron pipe has been used for this project.

4. COMPONENTS

4.1 DC motor

DC motor was used to convert electric energy into mechanical energy. DC motor provides high torque with better efficiency, less operating and maintenance cost over fossil fuels and light in weight. Therefore, a DC Motor was considered viable option for machine which was selected as per the calculated values. The selection of this motor for a tiller machine is dependent on power requirements of the machine.



Fig 2. Motor

Table 4.1 Specification of Dc motor

Specification of Dc motor		
S.No.	Parameters	Details
1	Voltages	24 volts DC
2	Power	250 watt = 0.25 kw
3	Speed before load	3000 rpm
4	Speed after load	300 rpm
5	Motor torque	11 N/m
6	Current	19.2 amp

4.2 Bicycle Rim

The bicycle rim is of 20 inch in diameter. Sprocket is mounted on the rim and with the help of the chain the desired motion is achieved.



Fig 3. Bicycle Rim

4.3 Battery

A battery consists of one or more cells, in which chemical energy is converted into electrical energy and used as a source of power. In this, we use two batteries and their capacity is 24v. They are connected in series. These types of batteries are used in electric bikes, electric cycles, e-rickshaws, etc. The battery backup is 4-6 hrs. The battery will be rechargeable.



Fig 4. Battery

Table 4.3 Specification of Battery

Specification of Battery		
S.No..	Parameters	Details
1	No. of Battery	2

2	Operating voltage	12+12 = 24 Volt
3	Voltage output	12+12 = 24 Volt
4	Battery capacity	4+4 = 8 Ah

4.4 Speed regulator

Speed control is an electric circuit used to control the speed of the motor. This control is done by the knobs which are linked to the potentiometer provided in the circuit. Through this, the operator can change the motor speed according to the requirements. This gives the required operational speed. The speed can be controlled by altering the voltage with the help of knobs.

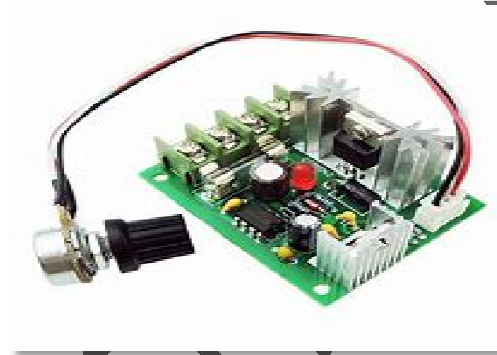

Fig. 5. Speed Regulator

Table 4.4 Specification of Speed Regulator

Specification of Speed Regulator		
S.No.	Parameters	Details
1	Operating voltage (VDC)	9~55 volt
2	Max. Operating current (A)	40 A
3	Maximum Power	2000W
4	Speed Range	0-100%

4.5 Angle bar

Angle bar of mild steel and they are mounted on rim of the wheel. The main function is to move the rim easily through the sand.



Fig 6. Angle bar

4.6 Chain

For transferring the power from drive sprocket to driven sprocket, a pintle chain was used for heavy-duty, slow-speed work in any exposed atmosphere. It is made of malleable links, held together by suitable pins. The pitch of the chain is 12.7cm.

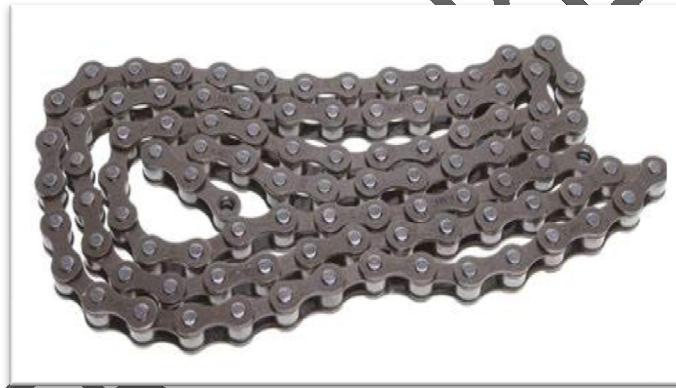

Fig. 7. Chain

4.7Axle

The machine consists of an arrangement of wheel and axle that helps it move forward. Here, the force applied to the axle initiates the motion and causes the wheels of the cycle to move. Axle is presented in the center of the wheel.

5. MODELLING

5.1 Solidworks

The virtual model is created by using Solidworks modeling software to analyze the model. The dimension is considered as per the physical model and a rough diagram of the portable electric tiller and cutter machine is drawn. Then create a CAD model.

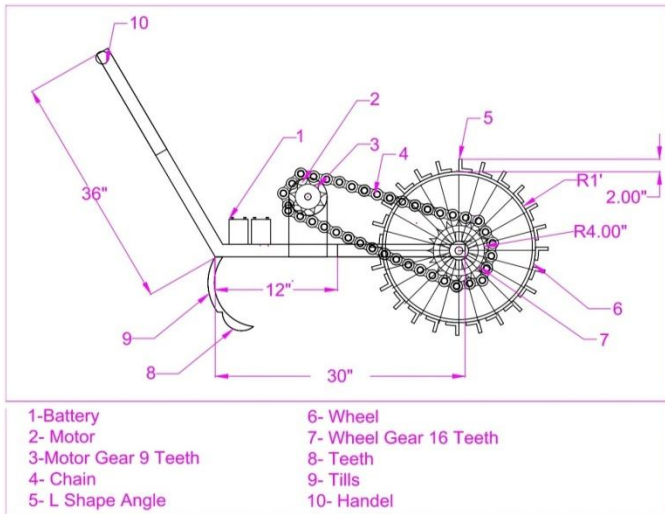

Fig. 8. CAD view of Machine

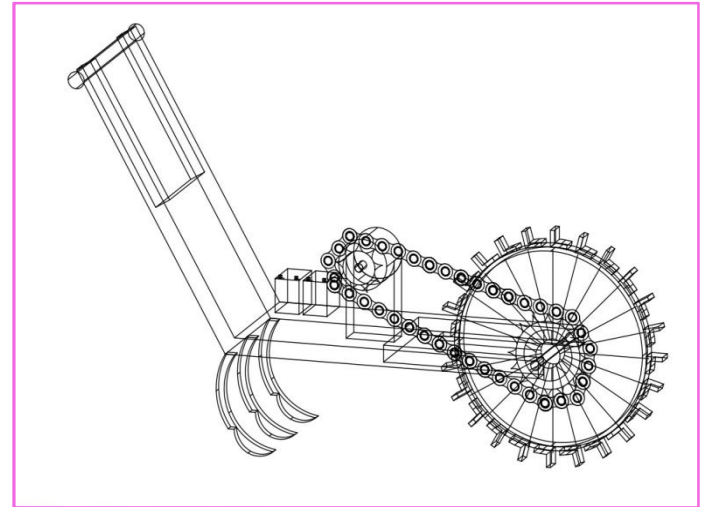

Fig. 9. Line Diagram of Machine

6. WORKING

The machine works on a DC motor which gives power to the overall system to run the object. The machine is driven by a DC motor which is in contact with the chain drive which ultimately helps to run the working wheels of the tiller during operation. For the tiller machine, the neat and accurate modification of the supporting frame is provided. For the tiller machine, the neat and accurate modification of the supporting frame is provided which gives an output voltage of fixed proposition. It is in such a way that magnitude remains constant and input voltage doesn't change for conditions of voltage. The regulator is connected to the main wire which is connected to the switch. The regulator and wire are connected to the motor to run the operation. The motor is fitted to a suitable angle as per stability for a worker during operation. Wheels are provided for ease in working during agriculture.

7. FABRICATION

Following the selection of materials that are light in weight, durable, and readily available, such as a rectangular iron pipe. Several machining processes are performed on the material. Clamps, Handle, supports, rectangular iron frames, and other elements are tiller type. In the fabrication, we do the cutting, drilling, welding, and shaping operations. Other operations are bending of tiller type. Bench-wise clamping is used to prepare the clamps. All operations are done in the fabrication of the project.



Fig.10. Assembled project model

8. ADVANTAGES

1. Automatic Operation
2. Battery Powered No Fuel Needed
3. Portable and easy to operate
4. Cost-effective as compared to a tractor
5. Replacement for animal power & human effort.
6. Reduces tilling time

9. DISADVANTAGES

1. Needs charging when battery runs out.
2. Clean after every use.

10. APPLICATION

1. In agriculture field for preparation for seed sowing.
2. For Plugging.
3. For softening land.
4. For cultivation of soil.
5. Soil preparation for seed sowing.

11. FUTURE SCOPE

1. Various processes along with plugging could be done such as seeding and spraying by adding more attachments.
2. More operations can be included to the machine like pesticide sprayer, tiller and many other machines for various operations.
3. By making modification same machine with able to changing the different rotary tool for different purpose example rotary tool for cutting purpose, digging purpose
4. By making further modification using large power generated solar panel.
5. By making modification in increasing the speed of the motor.

12. CONCLUSION

The portable motor operated tiller machine is capable of primary and secondary tillage operations and is most suitable for operations in hilly regions, wet conditions, and small holdings. Given the right set of implements and attachments, the portable motor operated tiller machine is capable of performing most of the field operations in intensive cultivation. The lightweight of portable motor-operated tiller machine is a favorable factor for working in wet and dry land conditions. External attachments can be made on the tiller depending upon the nature of the work. So, the tiller can be used as a multi-purpose machine.

REFERENCES

1. Ashvi Patel and Dhanashree Ingle “Design & Fabrication of Power Tiller by Using Scooter Engine”. International Journal of Disaster Recovery & Business Continuity: journal. vol. 11, No. 3 May2020.
2. R.magesh Kumar and M.Mayakannan, “Design and Fabrication of Battery Operated Weeder Machine” International Research Journal of Engineering and Technology, vol. 07, no. 05,IRJET-2020, May-2020.
3. Ashish Kumar, “Solar Power Tiller,” International Journal of Scientific Engineering Research, vol. 9,Issue.10, October-2018.
4. Ashish Kumar, “Solar Power Tiller,” International Journal of Scientific Engineering Research, vol. 9,Issue.10, October-2018.