

**Development of a Domestic Water Medium Rice De-  
Stoning Machine**

**ABSTRACT**

Local rice processing by small scale agro-processor has suffered tremendous setback ranging from stone presence and foreign materials in processed rice. It has become critical to develop a domestic rice de-stoning machine that can be utilized by small scale agro-processors. As a result of these bottlenecks this

paper has focused on developing a destoning machine that utilizes water medium for stone separation. The design was built using locally accessible materials. Major components of the machine being reservoir, hopper, de-stoning chamber, washing chamber, impeller, water filter, and brush drum. The developed de-stoning machine was powered by a 1.8 kW variable electric motor that communicated the rotating motion of the driving pulley to the driven pulley, which was supported by bearings, through a V-belt. The machine was developed and evaluated for its efficiencies with respect to stone separation and rice cleaning using 2 kg clean rice with 20 incorporated small stones of different sizes. It was discovered that 2kg/10minutes and 20.04kg/hour of processed rice were de-stoned at a speed of 400rpm, which is the optimal speed for maximum separation process. The de-stoning machine's effectiveness in terms of stone removal is approximately approaching 100 percent free of impurities. This discovery elucidates the potential to deal with the challenges of stone removal from locally produced rice using hand and manual method, which are inefficient, time and energy consuming, therefore this developed machine acts as a rice processing industry innovation.

Local rice processing by small-scale agro-processor has suffered tremendous setbacks ranging from the stone presence and foreign materials in processed rice. It has become critical to develop a domestic rice de-stoning machine that small-scale agro-processors can utilize. Because of these bottlenecks, this paper has focused on developing a destoning machine that utilizes a water medium for stone separation. The design was built using locally accessible materials. The machine's major components are the reservoir, hopper, de-stoning chamber, washing chamber, impeller, water filter, and brush drum. The developed de-stoning machine was powered by a 1.8 kW variable electric motor that communicated the rotating motion of the driving pulley to the driven pulley, supported by bearings, through a V-belt. The machine was developed and evaluated for its efficiencies for stone separation and rice cleaning using 2 kg clean rice with 20 incorporated small stones of different sizes. It was discovered that 2 kg/10 minutes and 20.04 kg/hour of processed rice were de-stoned at a speed of 400 rpm, which is the optimal speed for the maximum separation process. The de-stoning machine's effectiveness in terms of stone removal is approximately approaching 100 per cent free of impurities. This discovery elucidates the potential to deal with the challenges of stone removal from locally produced rice using hand and manual methods, which are inefficient, time and energy-consuming; therefore, this developed machine acts as a rice processing industry innovation.

Keywords: *Rice, Rice-Destoner, Water medium, Stone, Separation*

## **1. INTRODUCTION**

Rice, (*Oryza sativa*) is a monocot crop that may persist as a perennial crop in tropical places. Rice is among the three major crops in the world, which contribute greatly to satisfy the food needs in the world[1]. Rice is a staple meal for more than half of the world's population of 100 million people and is highly competitive in international trade. In Nigeria, over the last 10 years, rice farming remained one of the major notable agricultural development [2; 3]. According to 2021 study, global rice production has a

record of 513.0 million tons. Globally, India, China, Pakistan, Australia, Bangladesh, Cote d'Ivoire, Nigeria, Paraguay, South Korea, Senegal, and Thailand account for the bulk of the projected global rice production increase in 2021, with Australia, Bangladesh, China, India, and Thailand showing the largest year-to-year increases [4; 5].

In Nigeria rice has demand per capita of 32kg indicating 4.7% increase in the past ten years making the total demand to be 6.4 million tons in 2017 as against 3.7 million tons yield per year [6]. Rice is used for different varieties in Nigeria while the most common form of food prepared with rice all over the country include parboiled rice eaten with stew, popped and puffed rice, rice flakes, canned rice and fermented produce [7]. Rice husk is used for producing paper and as a source of fuel. Rice bran is used as animal feed, Rice bran oil is used in soap industry and rice bran wax, a byproduct of rice bran oil is used in industries [8]. However, stones, sand particles, dirt, chaffs, and other contaminants have been discovered in locally produced rice in Nigeria, contributing to its low quality and poor market appeal. These foreign elements or contaminants are frequently introduced into rice during harvesting, threshing, handling, packing, and other processes. This has been a militating factor affecting local rice's demand and potential for export.

According to Ojedian *et al.* [9], the crude methods used in the harvesting and post-harvesting practices of rice in Nigeria causes high presence of impurities. As a result of this, cleaning must be done as a pre-processing procedure to remove unwanted materials. De-stoning is the process of removing stones or contamination from various crops of different sizes and colors and it's a very important processing handling in rice processing. During harvesting, mud is attached to the stem of rice and it dries up to become sand and stones which can only be removed from the grain by cleaning. Also, parboiled rice is often dried by local processors on the bare floor platforms or slabs under direct sun, which could also result in stones and other dry impurities being introduced into the rice. Hence, cleaning, as a preliminary operation, must be extensively carried out to remove the unwanted materials or impurities from rice to increase the quality of locally produced rice and in order to increase its acceptability by consumers [10]. In order to completely remove all the stones/sand and impurities from the seeds the use of rice destining machine is of great significance. These limitations necessitate need for appropriate technologies for cleaning locally processed rice. This study, therefore, developed a domestic rice de-stoner using water with a view to make better quality, increase productivity, and to reduce the drudgery involved in rice cleaning.

Rice (*Oryza sativa*) is a monocot crop that may persist as a perennial crop in tropical places. Rice is among the three major crops in the world, contributing greatly to satisfying the food needs of the world [1]. Rice is a staple meal for more than half of the world's population of 100 million people and is highly competitive in international trade. In Nigeria, over the last 10 years, rice

farming remained one of the major notable agricultural development [2; 3]. According to a 2021 study, global rice production has a record of 513.0 million tons. Globally, India, China, Pakistan, Australia, Bangladesh, Cote d'Ivoire, Nigeria, Paraguay, South Korea, Senegal, and Thailand account for the bulk of the projected global rice production increase in 2021, with Australia, Bangladesh, China, India, and Thailand showing the largest year-to-year increases [4; 5].

In Nigeria, rice has a demand per capita of 32 kg, indicating a 4.7 % increase in the past ten years, making the total demand 6.4 million tons in 2017 as against 3.7 million tons yield per year [6]. Rice is used in different varieties in Nigeria, while the most common food prepared with rice all over the country includes parboiled rice eaten with stew, popped and puffed rice, rice flakes, canned rice, and fermented rice produce [7]. Rice husk is used for producing paper and as a source of fuel. Rice bran is used as animal feed, Rice bran oil is used in the soap industry, and rice bran wax, a byproduct of rice bran oil, is used in industries [8]. However, stones, sand particles, dirt, chaffs, and other contaminants have been discovered in locally produced rice in Nigeria, contributing to its low quality and poor market appeal. These foreign elements or contaminants are frequently introduced into rice during harvesting, threshing, handling, packing, and other processes, which has been a militating factor affecting local rice's demand and potential for export.

According to Ojadiran *et al.* [9], the crude methods used in rice harvesting and post-harvesting practices in Nigeria cause a high presence of impurities. As a result, cleaning must be done as a pre-processing procedure to remove unwanted materials. De-stoning removes stones or contamination from various crops of different sizes and colours, and it is a very important processing handling in rice processing. During harvesting, mud is attached to the rice stem and dries up to become sand and stones, which can only be removed from the grain by cleaning. Also, parboiled rice is often dried by local processors on bare floor platforms or labs under direct sun, which could also result in stones and other dry impurities being introduced into the rice. Hence, as a preliminary operation, cleaning must be extensively carried out to remove unwanted materials or impurities from rice to increase the quality of locally produced rice and increase its acceptability by consumers [10]. In order to completely remove all the stones/sand and impurities from the seeds, using a destining rice machine is of great significance. These limitations necessitate the need for appropriate technologies for cleaning locally processed rice. Therefore, this study developed a domestic rice de-stoner using water to make better quality, increase productivity, and reduce the drudgery involved in rice cleaning.

## 2. PREVIOUS STUDIES

Preceding the invention of rice de-stoning machine, farmers make use of local method to remove impurities and stones from rice. The local method includes removal of stone using hand, sieving, winnowing, removal of stones using water in a bowl or calabash, but this is time exhausting, not efficient and also not hygienic. The need to improve the quality of rice for domestic consumption at reduced time and less stress has necessitated the invention of a domestic rice de-stoning machine [11]. Researchers like, Simonyan *et al.* [12], Adegun *et al.* [13], Adejuyigbe and Bolaji [14], Olugboji and Jiya [15], Okunola *et al.* [16], Ojadiran *et al.* [9], Ohwofadjeke [3] have designed and fabricated machines for the separation of stones/sand and other impurities from processed rice and cereals to meet the public demand. This has

impart many new innovations and technique of removing impurities from rice. Adejuyigbe and Bolaji [14], for example, developed and fabricated a rice de-stoning machine using a vibrating sieve and achieved a high destoning efficiency. Okunola *et al.* [16], developed a cereal cleaner capable mostly for use in processed rice cleaning contaminants. Yet, using a separator in removing impurities from the rice is stressful and sufficient drying will be required to avoid the possibility of fungi or mold growth on the rice during storage [17]. Ojediran *et al.* [9] developed a motorized rice de-stoning machine but the technical definition of the designed machine, nevertheless, are very complex and hard to reveal and this situation was also recorded in the design of Ogunlowo and Adesuyi, [10], Simonyan *et al.* [12], Adegun *et al.* [13] and Agidi *et al.* [18]. Whereas lot of imported rice de-stoning machine are very costly. The ones being developed in Nigeria uses dried method with high grain breakage record, tray loses and also, stones that are relatively of the size of rice are not effectively separated.

Preceding the invention of the rice de-stoning machine's invention, farmers used local methods to remove impurities and stones from rice. The local method includes the removal of stones using hand, sieving, winnowing and removing stones using water in a bowl or calabash, but this is time exhausting, inefficient and also not hygienic.

The need to improve the quality of rice for domestic consumption at reduced times and with less stress has necessitated the invention of domestic rice as the de-stoning machine [11].

Researchers like, Simonyan *et al.* [12], Adegun *et al.* [13], Adejuyigbe and Bolaji [14], Olugboji and Jiya [15], Okunola *et al.* [16], Ojediran *et al.* [9], Ohwofadjeke [3] have designed and fabricated machines for the separation of stones/sand, and other impurities from processed rice and cereals to meet the public demand, which has imparted many innovations and techniques for removing impurities from rice.

Adejuyigbe and Bolaji [14], for example, developed and fabricated a rice de-stoning machine using a vibrating sieve and achieved a high destoning efficiency. Okunola *et al.* [16] developed a cereal cleaner capable mostly of use in processed rice cleaning contaminants. However, using a separator to remove impurities from the rice is stressful, and sufficient drying will be required to avoid the possibility of fungi or mould growth on the rice during storage [17]. Ojediran *et al.* [9] developed a motorized rice de-stoning machine. However, the technical definition of the designed machine is very complex and hard to reveal. This situation was also recorded in the design of Ogunlowo and Adesuyi [10], Simonyan *et al.* [12], Adegun *et al.* [13] and Agidi *et al.* [18]. In comparison, many imported rice de-stoning machines are very costly. The ones being developed in Nigeria use the dried method with high grain breakage record and tray loss, and stones relative to the rice size need to be more effectively separated.

The wet method uses water as a medium of separation with preference to bulk density differences between of stone/sand (1.33g/cm<sup>3</sup>) and rice(0.51g/cm<sup>3</sup>). Large quantity of rice float with the water while the stones settled down at the bottom of the container and be collected at the coarse surface. There is no breakage of rice and tray losses due to vibration from the machine. Stone that are relatively the same size of the rice were separated and the rice is properly clean. This provide a good efficiency in solving the traditional method of stone removal from our locally produced rice.

The wet method uses water as a medium of separation with a preference for bulk density differences between stone/sand (1.33 g/cm<sup>3</sup>) and rice (0.51 g/cm<sup>3</sup>). A large quantity of rice floats with the water while the stones settle down at the bottom of the container and are collected at the coarse surface. There is no breakage of rice and tray losses due to vibration from the machine. The stone that is relatively the same size as the rice was separated and properly cleaned, which provides good efficiency in solving the traditional stone removal method from our locally produced rice.

### 3. METHODOLOGY

#### 3.1 Design Considerations

The design considerations were completely accomplished to find the important design measurable factors and material strength that can give the best design results. Based on critical material analysis, adequate and efficient rice-destoning process, the following design factors were taken to consideration, surface polish, strength, corrosion, interaction with the environment, fabrication cost, maintenance cost, and material availability, manufacturing simplicity and material safety.

The design considerations were completely accomplished to find the important design measurable factors and material strength that can give the best design results. Based on the critical material analysis and adequate and efficient rice-destoning process, the following design factors were considered: surface polish, strength, corrosion, interaction with the environment, fabrication cost, maintenance cost, material availability, manufacturing simplicity, and material safety.

#### 3.2 Machine Component Design Calculation

Table 1: Parameters of other functioning parts of the Machine

S/N	Design Factor	Design Equations	Design Values
1	Volume of a hopper	$V_h = \frac{h}{3} (A_1 + A_2 + \sqrt{A_1 \times A_2})$	0.014128615 m <sup>3</sup>
2	Volume of the de-stoning chamber	$V_{des} = \pi r^2 h$	1.0054×10 <sup>-3</sup> m <sup>3</sup>
3	Volume of rice and stone in the destoning chamber	$V_R = \frac{1}{3} V_{des}$	3.3515×10 <sup>-3</sup> m <sup>3</sup>
4	Mass of rice	$\rho = \frac{m}{v}$	14.60kg
5	Mass of impeller (blade)	$V_b = L \times W \times T$	0.73125kg
6	Mass of shaft of impeller	$M_s = \rho \times v$	3.08kg

7	Mass of the rotating impeller	$M_{RI} = M_s + M_b$	3.81kg
8	Mass of water in the destoning chamber	$M_{water} = \rho \times v$	6.7029kg
9	Total mass of destoning chamber	$TM_{dsc} = M_R + M_{RI} + M_{water}$	25.11kg
10	Power of electric motor	$P = T \times \omega$	1.452 kw
11	The driven pulley diameter	$D_2 = D_1 \frac{N_1}{N_2}$	175 mm
12	Speed ratio of the belt drive	Speed Ratio = $\frac{N_m}{N_s} = \frac{D_s}{D_m}$	576 rpm
13	Peripheral belt speed	$V = \frac{2\pi N_s}{60} \times \frac{D_s}{2}$	5.28 m/s
14	Length of the belt	$L_p = \frac{\pi}{2} + (D_1 + D_2) + 2C + \frac{(D_2 - D_1)^2}{4C}$	42.59"
15	Mass of the belt per unit length	$M = area \times length \times density$	0.1125kg/m
16	Groove angle	$\sin \alpha = \frac{r1 - r2}{x} = \frac{d1 - d2}{x}$	12.12°
17	Angle of contact	$\phi = 180 - 2\alpha$	2.85 rads
18	Belt tension	$2.3 \log (T_1/T_2) = \mu\theta cosec\beta$	50.68 N
19	Power transmitted by belt	$P = (T_1 - T_2)v$	1.6166 kW
20	Required number of belt	$\frac{Number\ of\ Belts}{Total\ power\ transmitted} = \frac{Power\ transmitted\ per\ belt}$	1 belt
21	Volume of the washing chamber	$V_{was} = \pi r^2 h$	3.4222×10 <sup>-3</sup> m <sup>3</sup>
22	Mass of brush drum in the washing chamber	$M_{brush} = \rho \times v$	4.8kg
23	Work done by the brush drum	$W_{brush\ drum} = mg \times d$	135N
24	Volume of reservoir	$V_{res} = \pi r^2 h$	5.656×10 <sup>-3</sup> m <sup>3</sup>
25	Flow rate	$Q = \frac{V}{T}$ or $Q = AV$	3.57 L/S
26	Torque transmitted by the shaft	$T = \frac{P \times 60}{2\pi N}$	33.15×10 <sup>3</sup> Nmm
27	Shaft diameter	$T = \frac{\pi}{16} \times \tau \times d^3$	14 mm
28	Twisting moment	$T_e = (Mb^2 + T^2)$	101.902 m

### 3.2.1 Hopper Capacity

The volume of the hopper is a function of the dimension of the rice which also depends on the volume of the riceto be fed into the de-stoning chamber per batch.

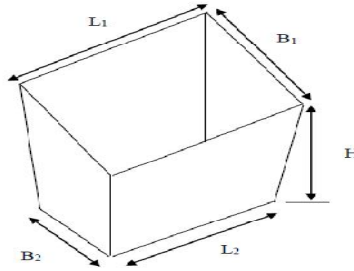

Figure 1: Isometric view of the hopper

Volume of hopper according to Masser and Jensen [19]; and Eric *et al.* [20] is expressed in equation 1;

$$V_h = \frac{h}{3} (A_1 + A_2 + \sqrt{A_1 \times A_2}) \quad (1)$$

Where;

$V_h$  is Volume of hopper,  $A_1$  is Hopper inlet area,  $L_1$  is Length of outlet point,  $B_1$  is Breadth of outlet point,  $A_2$  is Hopper outlet area,  $L_2$  is Length of inlet point;  $B_2$  is Breadth of inlet point and  $H$  is vertical height of hopper

$$\begin{aligned} A_1 &= 0.0224 \text{ m}^2, A_2 = 0.00805 \text{ m}^2, H = 0.07 \text{ m} \\ V_h &= \frac{0.07}{3} (0.0224 + 0.00805 + \sqrt{0.0224 \times 0.00805}) \\ V_h &= 0.014128615 \text{ m}^3 \\ &= 0.0141 \text{ m}^3 \end{aligned}$$

The calculated capacity of  $0.0141 \text{ m}^3$  will allow the operator to feed the machine as many times as possible. This prevents overloading or any form of clogging when the machine is in operation.

### 3.2.2 Capacity of the De-Stoning Unit

The capacity of the de-stoning unit ( $V_{des}$ ) is given by equation (2) according to Adegunet *al.* [13],

$$V_{des} = \pi r^2 h \quad (2)$$

Equation 2 was used because the de-stoning chamber is in form of a cylinder

Where;

$d$  is diameter of the destoning chamber = 160 mm,  $r$  is radius of destining chamber = 80 mm and  $h$  is height of destining chamber = 500 mm

$$\begin{aligned} V_{des} &= \pi \times (80)^2 \times 500 \\ &= 0.0100544 \text{ m}^3 \\ V_{des} &= 1.0054 \times 10^{-3} \text{ m}^3 \end{aligned}$$

### 3.2.3 Total Mass of the De-stoning Chamber

The Total Mass of the de-stoning chamber was calculated using equation (3) according to Adejuyigbe and Bolaji [14],

$$TM_{dsc} = M_R + M_{RI} + M_{water} \quad (3)$$

Where;

$TM_{dsc}$  is total mass of de-stoning chamber,  $M_R$  is mass of rice,  $M_{Ri}$  is mass of rotating impeller and  $M_{water}$  is mass of water  
 $TM_{dsc} = 14.60 + 2.93 + 6.70$   
 $= 25.11 \text{ kg}$

### 3.2.4 Speed of the Impeller (Agitator)

$$V = \frac{D_s}{D_L} = \frac{N_L}{N_s} \text{ (Ojediranet al., [9])} \quad (4)$$

Where;

$V$  is speed of the impeller (agitator),  $D_s$  is driving pulley diameter,  $D_L$  is driven pulley diameter,  $N_s$  is speed of driving pulley in revolution per minute and  $N_L$  is speed of driven pulley in revolution per minute.

$N_s = 1440 \text{ rpm}$ ,  $D_s = 70 \text{ mm}$  and  $D_L = 175 \text{ mm}$

$$N_L = \frac{70 \times 1440}{175}$$

$$= 576 \text{ rev/min}$$

### 3.2.5 Shaft Design

The purpose for the design of shaft is to ensure the appropriate firmness and rigidity needed to transfer a useful force is ensured. The firmness in the twisting force of shafts made of ductile materials are usually calculated on the fundamental of the maximum shear theory. The shear force diagram of the shaft is represented in Figure 2.

Loads acting on the shafts are three impeller blade, brush drum and pulley. Dimensions of components on the shafts was based on the shape and size of the impeller.

#### a) Impeller blade

The number of the blade is a function of the maximum volume of the rice in the destoning chamber during operation. Length of blade was chosen based on the distance between the wall of the destoning chamber and the clearance.

Determination of capacity of the impeller ( $V$ )

Total capacity of the impeller blade =  $0.0000325 \text{ m}^3$

Mass of the rotating impeller =  $3.81 \text{ kg}$

The shaft design aims to ensure that the appropriate firmness and rigidity needed to transfer a reasonable force are ensured. The firmness in the twisting force of shafts made of ductile materials is usually calculated on the fundamental of the maximum shear theory. The shear force diagram of the shaft is represented in Figure 2.

Loads acting on the shafts are three impeller blades, a brush drum and a pulley. Dimensions of components on the shafts were based on the shape and size of the impeller.

Impeller blade. The blade number is a function of the maximum rice volume in the destoning chamber during operation. The length of blade was chosen based on the distance between the wall of the destoning chamber and the clearance.

### Determination of capacity of the impeller (V)

The total capacity of the impeller blade =  $0.0000325 \text{ m}^3$

Mass of the rotating impeller =  $3.81 \text{ Kg}$

#### b) Beaters (blades)

The function of the beater is to complete the destoning processes by causing the turbulent of the rice and water.

Determination of weight of beaters ( $W_b$ )

Total weight of beater =  $2.39 \text{ N}$

#### c) Shaft of the impeller blade

The function of the shaft of the impeller blade is to provide rotational motion the blade that aid in destoning of the rice from stones.

Total weight of the shaft =  $30.21 \text{ N}$

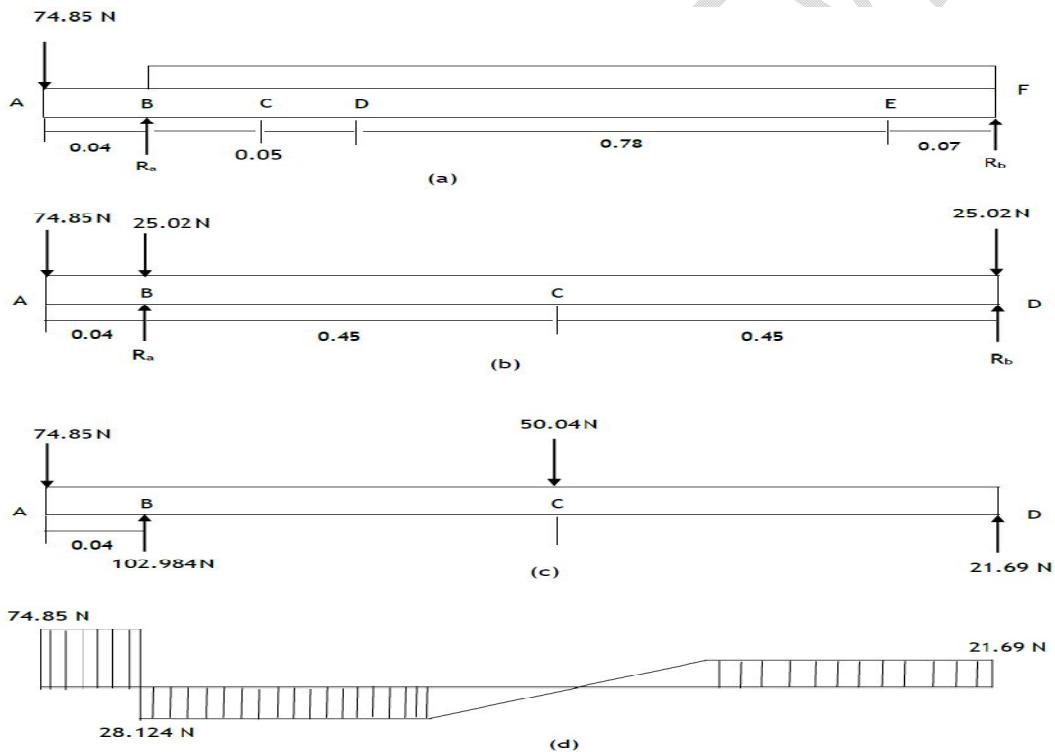

Figure 2: Shear Force Diagram of the Shaft

### 3.2.6 Determination of power required to drive the pulley and shaft

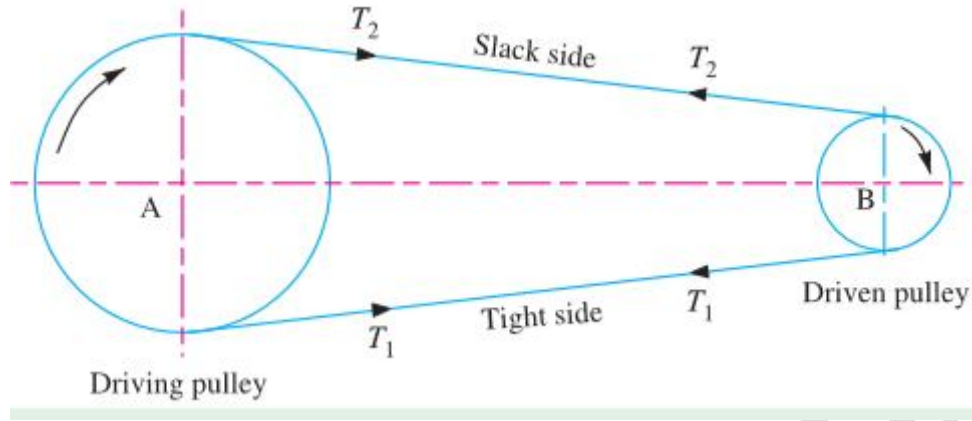

Figure 3: Power Transmitted by a Belt

Let;

$T_1$  = Tensions in the tight side of the belt,  $T_2$  = Tensions in the slack side of the belt in Newton's,  
 $r_1$  = radii of the driving pulley,  $r_2$  = radii of the driven pulleys in meters and  $v$  = velocity of the belt in m/s.  
 The efficient rotational force at the circumference of the driven pulley is the difference between the two tensions,  $T_1$  and  $T_2$ ).

Therefore, the power transmitted per belt,  $P$ , is given in equation (5) as recorded by Adejuyigbe and Bolaji [14],

$$\begin{aligned}
 P &= (T_1 - T_2) \times v & (5) \\
 &= (356.85 - 50.68) \times 5.28 \\
 &= 1.6166 \text{ kW}
 \end{aligned}$$

Therefore, A 2 kW prime mover and electric motor of 10.37kW were selected

### 3.2.7 Determination of Shaft Diameter

For a solid shaft made from malleable material having no axial loading, the shaft diameter is obtained from the American Society of Mechanical Engineers (ASME) code equation according to Khurmi and Gupta [21] and presented in equation (6).

$$\frac{T}{J} = \frac{\tau}{r} \quad (6)$$

Where;

$T$  is the twisting moment,  $J$  is the Polar moment of inertia,  $\tau$  is torsional shear stress and  $r$  is the distance from neutral axis

$$T = \frac{\pi}{32} \times \tau \times d^4 \quad (7)$$

And it was simplified into equation (8)

$$T = \frac{\pi}{16} \times \tau \times d^3 \quad (8)$$

To determine the twisting moment transfer by the shaft in equation (8) becomes,

$$T = \frac{P \times 60}{2\pi N} \quad (9)$$

Where;

P is the power required to run the shaft 2 kw, N is the output speed of transmission shaft 576 rpm

$$T = \frac{2000 \times 60}{2\pi \times 576} = \frac{120000}{3619.584}$$

$$= 33.153 \text{ Nm}$$

$$T = 33.15 \times 10^3 \text{ Nmm}$$

$$T = \frac{\pi}{16} \times \tau \times d^3$$

$\tau = 56 \text{ MPa}$  for shafts without allowance for keyways, according to Gupta and Khurmi (2005)

$$33.15 \times 10^3 = \frac{\pi}{16} \times 56 \times d^3$$

$$d = 14.44 \text{ mm}$$

Therefore, a shaft of 14 mm was selected.

### 3.2.8 Belt design and selection

Since it is a 3-way pulley system, the conventional belt calculation formula will not be applicable. Equations according to William, [22] and Usman *et al.* [23] will be considered to resolve the calculation for the belt length.

From Figure 4,

AD = Pulley A diameter,

BD = Pulley B diameter

CD = Pulley C diameter

a is the center distance between of pulley B and C

b is the center distance between of pulley C and A

c is the center distance between of pulley A and B

Total length of belt = L

$$L = HJ + DE + FG + \text{arclengths } FE + GH + DJ \quad (10)$$

$$L = a' + b' + c' + I\alpha' + I\beta' + I\gamma' \quad (11)$$

$$\beta = \cos^{-1} (c^2 + a^2 - b^2) / 2ca \quad (12)$$

$$\gamma = \cos^{-1} (a^2 + b^2 - c^2) / 2ab \quad (13)$$

$$\alpha = \cos^{-1} [(38^2 + 78^2 - 64^2) / (2 \times 38 \times 78)] = 54.6^\circ$$

$$\beta = \cos^{-1} [(78^2 + 64^2 - 38^2) / (2 \times 78 \times 64)] = 28.9^\circ$$

$$\gamma = \cos^{-1} [(64^2 + 38^2 - 78^2) / (2 \times 64 \times 38)] = 96.4^\circ$$

$$\alpha' = 6.284 - \cos^{-1} \left[ \frac{(6 - 15)}{78} \right] - \cos^{-1} \left[ \frac{(6 - 5)}{38} \right] - 54.6 = 233.44^\circ$$

$$\beta' = 6.284 - \cos^{-1} \left[ \frac{(15 - 5)}{64} \right] - \cos^{-1} \left[ \frac{(15 - 6)}{78} \right] - 28.9 = 187^\circ$$

$$\gamma' = 6.284 - \cos^{-1} \left[ \frac{(5 - 6)}{38} \right] - \cos^{-1} \left[ \frac{(5 - 15)}{64} \right] - 96.4 = 262.63^\circ$$

Applying the equation of circumference of a circle to determine the corresponding value of  $\alpha'$   $\beta'$   $\gamma'$  in meters.

$$C = 2\pi r$$

(14)

$$l\alpha' = 24 \text{ cm}, l\beta' = 28 \text{ cm}, l\gamma' = 23.08 \text{ cm}$$

Inserting derived values into Equation 10,

$$L = 63.21 + 37.99 + 77.48 + 24 + 50 + 23.08 = 276.7 \text{ cm} = 2.767 \text{ m}$$

Length of belt required is 2.767 m.

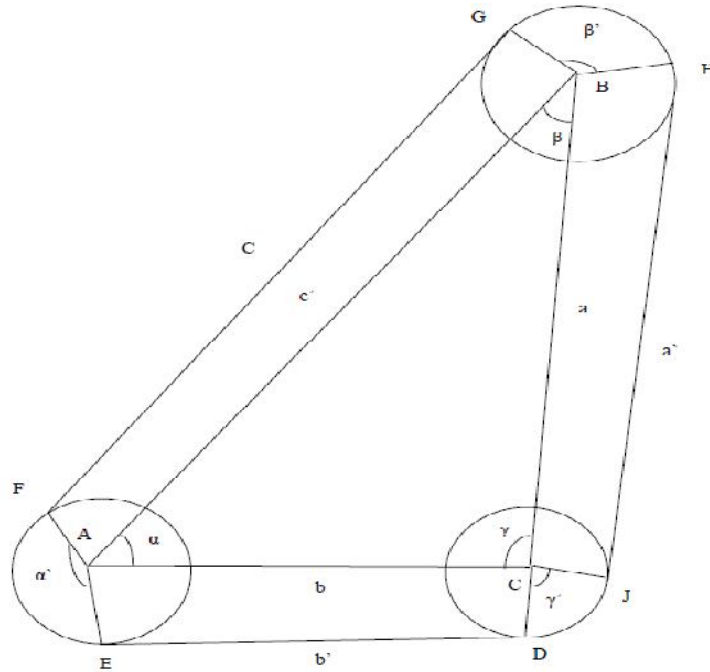

Figure 4: Schematic Diagram of the Belt and Pulley

### 3.3 Principle of Operation

The developed domestic rice de-stoning machine comprises of the reservoir, de-stoning chamber, washing chamber, and outlet. The de-stoning chamber which is made up of the hopper and impeller blade, is supported with the aid of a frame. The washing chamber unit has a brush drum positioned parallel to the de-stoning chamber unit.

At the commencement of the machine test, the complete system was subjected to a no-load test in order to ascertain its functionability. Separation experiment was conducted using 2kg of rice grain mixed with 20 pieces stone of different sizes fed through the hopper to the de-stoning chamber, a proportion which happens to be 1/3 of the volume of de-stoning chamber. Clean water was introduced into the chamber from the reservoir tank as the main separation medium. Variable speed electric motor with speed rating from 1400rpm to 10rpm was used which provide the motion of the shafts and rotate the impeller blade to stir the infested rice at a considerable speed and at given time. As a result of bulk density difference of stone/sand which is  $1.33\text{g/cm}^3$  (irregular in shape) while  $0.51\text{g/cm}^3$  for rice large quantity of rice float into the washing chamber for proper cleaning with the aid of brush drum and be collected at the rice outlet, while the stones settled down at the bottom of the de-stoning chamber and be collected at the coarse

surface. The water passes through a screen and is re-circulated to the reservoir to avoid water wastage. This same process was repeated for all experiments conducted at varying speeds to determine the effect of machine speed on separation efficiency of the developed machine.

The developed domestic rice de-stoning machine comprises the reservoir, de-stoning chamber, washing chamber, and outlet. The de-stoning chamber, made up of the hopper and impeller blade, is supported with the aid of a frame. The washing chamber unit has a brush drum parallel to the de-stoning chamber. At the commencement of the machine test, the complete system was subjected to a no-load test to ascertain its functionality. The separation experiment was conducted using 2 kg of rice grain mixed with 20 pieces of stone of different sizes fed through the hopper to the de-stoning chamber, a proportion which happens to be 1/3 of the volume of the de-stoning chamber. Clean water was introduced into the chamber from the reservoir tank as the main separation medium. Variable speed electric motor with a speed rating from 1400 rpm to 10 rpm was used, which provides the motion of the shafts and rotates the impeller blade to stir the infested rice at a considerable speed and at a given time. As a result of the bulk density difference of stone/sand, which is 1.33 g/cm<sup>3</sup> (irregular in shape) while 0.51 g/cm<sup>3</sup> for rice large quantity of rice floated into the washing chamber for proper cleaning with the aid of a brush drum and be collected at the rice outlet, while the stones settled down at the bottom of the de-stoning chamber and are collected at the coarse surface. The water passes through a screen and is re-circulated to the reservoir to avoid water wastage. This same process was repeated for all experiments conducted at varying speeds to determine the effect of machine speed on the separation efficiency of the developed machine.

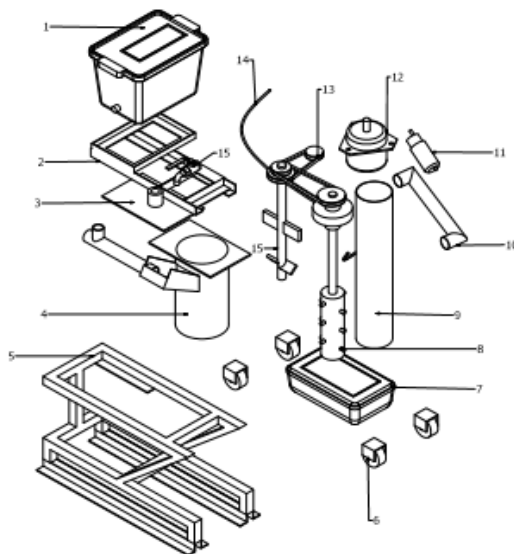

PART LIST		
S/N	DESCRIPTION	QTY
1	CLEAN WATER RESERVOIR	1
2	RESERVOIR SEAT	1
3	DESTONING CHAMBER COVER	1
4	DESTONING CHAMBER	1
5	MACHINE FRAME	1
6	TYRE	4
7	DIRTY WATER RESERVOIR	1
8	BRUSH	1
9	RICE-WATER SEPARATOR	1
10	WATER LINE	1
11	PUMP	1
12	ELECTRIC MOTOR	1
13	V-BELT AND PULLEY	1
14	HOSE	1
15	VALVE	1

Figure 5: Exploded View of the Rice De-stoner

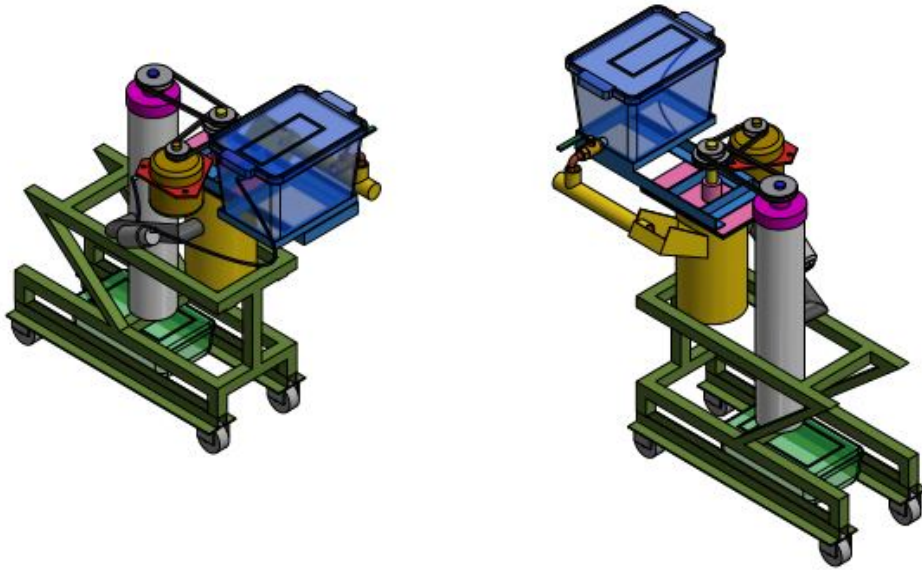

Figure 6: Three-Dimensional View of the Rice De-stoner

## 4. RESULT AND DISCUSSION

### 4.1 Machine Test Procedure

The developed rice destoner was tested using 2 kilogram of processed rice procured at a local market and 20 pieces of small stones of different sizes was mixed with the measured rice. The de-stoning operation was carried out at variable speed of 1400 rpm - 10 rpm using a single phase variable electric motor of 1440 rpm and a 1.8 kW power rating at a constant time of 10 minutes.

The separation effectiveness of the rice and stone obtained at different speeds are presented in Table 2 and graphically expressed in Figures 7 and 8.

The developed rice destoner was tested using 2 kilograms of processed rice procured at a local market, and 20 pieces of small stones of different sizes were mixed with the measured rice. The de-stoning operation was carried out at the variable speed of 1400 rpm - 10 rpm using a single-phase variable electric motor of 1440 rpm and a 1.8 kW power rating at a constant time of 10 minutes.

The separation effectiveness of the rice and stone obtained at different speeds are presented in Table 2 and graphically expressed in Figures 7 and 8.

**Table 2: Machine Performance Evaluation**

Speed (RPM)	Rice (g)	No of stones	Rice in washing chamber (g)	Stone(s) in washing chamber	Rice in de-stoning chamber (g)	Stone (s) in the de-stoning chamber
1400	2000	20	2000	20	0	0
1200	2000	20	1950	17	50	3
1000	2000	20	1940	15	60	5
800	2000	20	1935	10	65	10
600	2000	20	1930	4	70	16
400	2000	20	1928	0	72	20
200	2000	20	1800	1	200	19
100	2000	20	1500	2	500	18
50	2000	20	750	0	1250	16
30	2000	20	300	0	1700	20
20	2000	20	0	0	2000	20
10	2000	20	0	0	2000	20

## 4.2 Discussion of Results

Results from experimental procedures presented in Table 2 was analysed with respect to stone separation efficiency and rice cleaning efficiency. The effect of different operational parameters like percentage of stone separation, rice cleaning efficiency and de-stoning machine are presented and discussed.

### 4.2.1 Effect of machine speed on cleaning efficiency

Figure 7 shows the graphical representation of the effect of machine speed varying from 1400 rpm to 10 rpm. The experimental runs shows that at a very high speed of 1400rpm both the rice and the stone flow together as a result of high torque and there was no separation of stone from the rice. At a speed of 1200rpm, 3 pieces of stone were recovered whereas the remaining flow with the rice to the washing chamber which gives only 15% of stone removed. At 1000rpm, 800rpm, 600rpm, and 400rpm gives 25%, 50%, 80% and 100% stone removal respectively.

At a very low speed of 200rpm and 100rpm it was discovered that 5% and 10% stones were removal while at 50rpm, 30rpm, 20rpm and 10rpm gives 0% as there was no de-stoning of stone as a result of very low torque, it settled at the coarse surface of the de-stoning chamber and was collected through the stone outlet. This shows that the machine performs optimally at a speed of 400 rpm.

Results from experimental procedures presented in Table 2 were analysed concerning stone separation and rice cleaning efficiency. The effects of different operational parameters like percentage of stone separation, rice cleaning efficiency and de-stoning machine are discussed.

#### 1.1.1 Effect of machine speed on cleaning efficiency

Figure 7 shows the graphical representation of the effect of machine speed varying from 1400 rpm to 10 rpm. The experimental runs show that at a very high speed of 1400 rpm, the rice and the stone flow together due to high torque, and there was no separation of the stone from the rice. At a speed of 1200 rpm, 3 pieces of stone were recovered, whereas the remaining flowed with the rice to the washing chamber, leaving only 15 % of the stone removed. At 1000 rpm, 800 rpm, 600 rpm, and 400 rpm give 25 %, 50 %, 80 % and 100 % stone removal, respectively.

At very low speeds of 200 rpm and 100 rpm, it was discovered that 5 % and 10 % of stones were removed while at 50rpm, 30rpm, 20 rpm and 10 rpm gave 0 % as there was no de-stoning of stone as a result of very low torque, it settled at the coarse surface of the de-stoning chamber and was collected through the stone outlet, which shows that the machine performs optimally at a speed of 400 rpm.

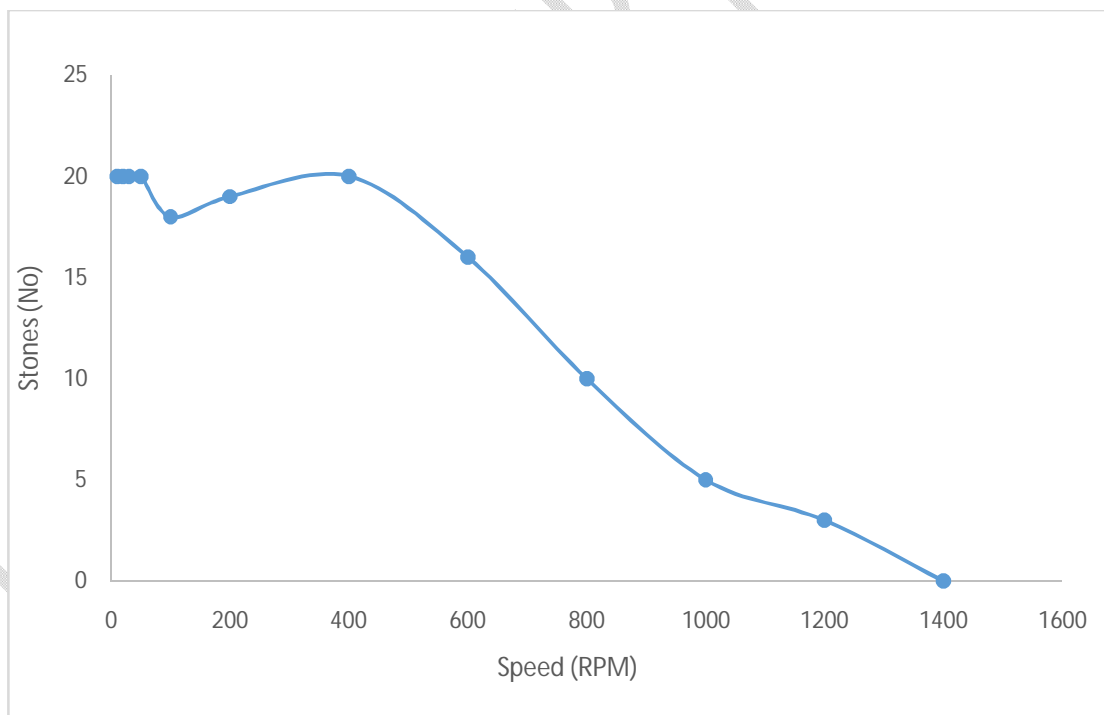

Figure 7: The Graph of Stone Separation

#### 4.2.2 Rice Cleaning Efficiency

This experiment was carried out to determine the amount of rice trapped in the machine during cleaning process. From the experiment conducted, it shows that the machine cleaning effectiveness increases as a result of resultant increase in speed of the impeller blade. Evaluation result as seen in Figure 8 revealed that cleaning efficiency recorded for machine at a very high speed of 1400rpm, there was no rice destoning as both the rice and stone flow together to the washing chamber as a result of high torque. When subjected to speeds of 1200rpm, 1000rpm, 800rpm and 600rpm the resulting rice cleaning efficiencies were 97.5%, 97%, 96.75% and 96.5% respectively.

At a very low speed of 200rpm and 100rpm the machine cleaning efficiencies were 90% and 75% respectively but contain some pieces of stone. Also, at 50rpm and 30rpm the rice cleaning efficiencies results in 37.5% and 15% respectively with only small quantity of rice without stones separated while at 20rpm and 10rpm there was no de-stoning of rice and stone as a result of very low torque both the rice and stone settled at the bottom of the de-stoning chamber.

This experiment was carried out to determine the amount of rice trapped in the machine during the cleaning process. The experiment shows that the machine cleaning effectiveness increases as a result of the resultant increase in speed of the impeller blade. As seen in Figure 8, the evaluation result revealed that cleaning efficiency was recorded for machine at a very high speed of 1400 rpm; there was no rice destoning as the rice and stone flowed together to the washing chamber as a result of high torque. When subjected to 1200 rpm, 1000 rpm, 800 rpm and 600 rpm, the resulting rice cleaning efficiencies were 97.5 %, 97 %, 96.75 % and 96.5 % respectively.

At a very low speed of 200 rpm and 100 rpm, the machine cleaning efficiencies were 90 % and 75 %, respectively but contained some pieces of stone. Also, at 50 rpm and 30 rpm, the rice cleaning efficiencies resulted in 37.5 % and 15 %, respectively, with only a small quantity of rice without stones separated, while at 20 rpm and 10 rpm, there was no de-stoning of rice and stone as a result of very low torque both the rice and stone settled at the bottom of the de-stoning chamber.

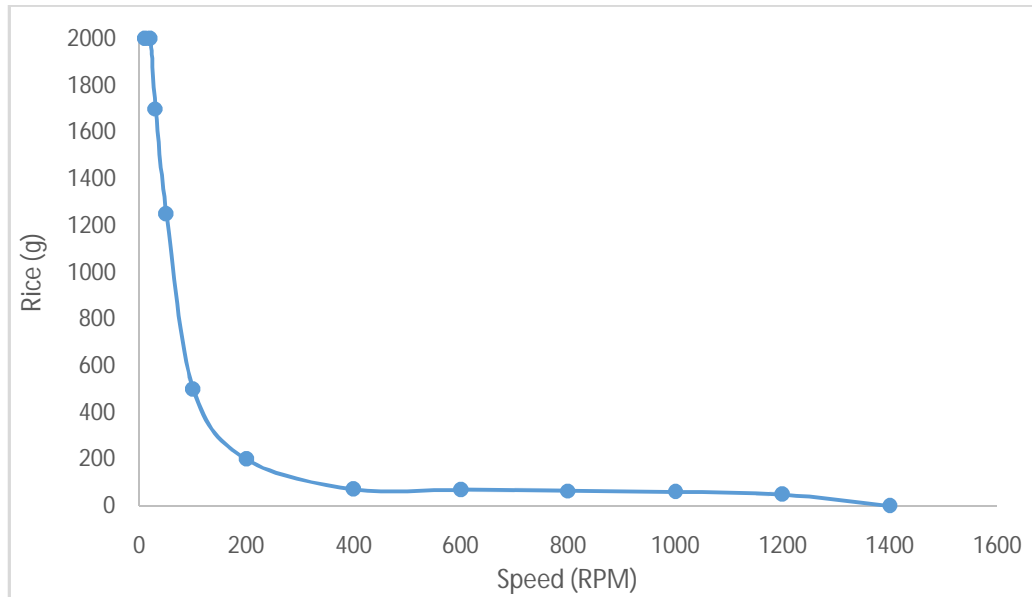

Figure 8: The Graph of Rice Separation

## 5. CONCLUSION

A water based de-stoning machine was developed and tested. The separation machine performed admirably in tests, according to the results as analyzed. The following are some of the work's particular conclusions. The machine's stone separation efficiency increases as the impeller's speed increases, vice versa. Rice separation efficiency also was experimentally recorded to increase with increasing speed with no rice loss or breaking. Based on the research outcome, it was deduced that there is increased separation efficiency using water based destining machine as compared to the conventional separating machine.

A water-based de-stoning machine was developed and tested. The separation machine performed admirably in tests, according to the results as analyzed. The following are some of the work's particular conclusions. The machine's stone separation efficiency increases as the impeller's speed increases, and vice versa. Rice separation efficiency also was experimentally recorded to increase with increasing speed with no rice loss or breaking. Based on the research outcome, it was deduced that there is increased separation efficiency using the water-based destining machine compared to the conventional separating machine.

## References

- [1] Bhagirath, S. C., Khawar, J. and Gulshan, M. (2017). Rice Production Worldwide, Springer International Publishing AG. 1st ed. 2017 Edition. 324-365.

- [2] Terungwa T. I. and Yuguda M. A. (2014). The impact of rice production, consumption and importation in Nigeria: The political economy perspective. *International journal of sustainable development and world policy* 3(4): 90-99.
- [3] Ohwofadjeke, P. O. (2020). Development of Low Cost Rice De-Stoning Machine. *International Journal of Engineering and Applied Sciences*, 7(1):5-12
- [4] Mishra, A. K., Pedde, V. O., Arouna, A., Labarta, R., Andrade, R., Veetil, P. C., Bhandari, H., Laborte, A. G., Balie, J. and Bouman, B. (2022). Helping feed the world with rice innovations: CGIAR research adoption and socioeconomic impact on farmers. *Global Food Security*. 33:100628.
- [5] Nathan, W. and Bonnie, L. (2022). Rice outlook: April 2022, RSC-22C, USDA, *Economic Research Service*. : 16
- [6] Mohammed, U. A., Ibrahim, S., Hayatu, M., Mohammed, F. A. (2019). Rice (*Oryza Sativa L.*) Production in Nigeria: Challenges and Prospects. *Dutse Journal of Pure and Applied Sciences* 5 (2b): 29-37.
- [7] Adeyeye, J. A., Navesero, E. P., Ariyo, O. J. and Adeyeye, S. A. (2010). Consumer Preference for Rice Consumption in Nigeria. *Journal of Humanities, Social Sciences and Creative Arts*. 5(1):26-36
- [8] Mohammed, D. T. (2016). Introduction of Faro-52 (WITA-4) Rice Variety as a Measure of Solving Low Yield Problem among Farmers in Yola-North Local Government Area of Adamawa State, Nigeria. *International Journal of Innovative Agriculture and Biology Research*. 4(2):1-7.
- [9] Ojediran, J. O., Okonkwo, C. E., Okunola, A. A. and Alake, A. S. (2019). Development of a Motorized Rice De-Stoning Machine. *Agricultural Engineering International: CIGR Journal*, 20(4): 202-209.
- [10] Ogunlowo, A. S. and Adesuyi S. A. (2014). Low-cost Rice Cleaning/De-Stoning Machine. *European Centre for Research Training and Development*. 2(2):33-43
- [11] Mohammed, G. Y., Fadeyibi, A., Katibi, K. K. and Ucheoma, O. C. (2017). Performance Evaluation and Modification of an Existing Rice Destoner. *International Journal of Engineering Technologies*. 3(3):196-175.
- [12] Simonyan, K. S, Emordi, I. S. and Adama, J. C. (2010). Development of a Locally Designed Rice De-stoning Machine. *Journal of Agricultural Engineering and Technology*. 18(2): 35-43.
- [13] Adegun I. K., Adepoju S. A. and Aweda J. A. (2012). A Mini Rice Processing Machine for Nigerian Farmers. *Journal of Agricultural Technology*. 8(4):1207-1216.
- [14] Adejuyigbe, S. B. and Bolaji. B. O. (2012). Development and Performance Evaluation of a Rice Destoning Machine Using Vibrating Sieves. *Journal of Natural Science, Engineering and Technology Agricultural Mechanization in Asia, Africa and Latin America*. 11(2): 94-105
- [15] Olugboji, T. O., and Jiya. F. (2014). Design and Fabrication of Rice De-Stoning Machine. *Food Science and Technology*, 2(1): 1-5.
- [16] Okunola, A. A., Igbeka, J. C. and Arisoyin, A. G. (2015). Development and evaluation of a cereal cleaner. *Journal of Multidisciplinary Engineering Science and Technology*. 2(6):14-19.

- [17] Bello, S., Eguoaje, S. O. and Eriakha E. C. (2019). Design, Fabrication and Performance Evaluation of a Rice Destoning Machine. *Journal of Natural Sciences Research*, 9(22): 56-65
- [18] Agidi, G. Ndagi, B. Kuku, A. M. and Abdullahi, L. (2015). Development and Testing of a Rice Destoning Machine. *International Journal Engineering Resources, Science and Technology*. 4(3): 118-129.
- [19] Masser, M. P. and Jensen, J. W. (1991). Calculating Area and Volume of Ponds and Tanks. SRAC Publication No. 103:1-8
- [20] Eric, O., Franklin, D. J. and Holbrook, L. H. (1982), Machinery Handbook, 21st edition, Industrial press Inc., New York. 24-26.
- [21] Khurmi, R. S. and Gupter, J. K. (2005). Machine Design, 14th Edition. New Delhi: Eurasia (PVT) Ltd. 509 - 758.
- [22] William, L.A. (1953). Mechanical Power Transmission Manual Conover - Mast Publ. New York. NY, USA. pp 165-174.
- [23] Usman, M. Balogun, A. L. and Oyebanre, O. D. (2018). Design, Fabrication and Testing of a Rice Destoning Machine. *International Conference of Science, Engineering and Technology*. 3(1):1-12.