

Enhancing Photovoltaic Power Generation through a Microcontroller-Driven Single-Axis Solar Tracker

ABSTRACT

Aims: The principal aim of this study is to make an automatic solar panel tracking system according to the sun's movement to maximize the energy generation of the solar panel from the sunlight. The purpose of this effort is to design an efficient microcontroller-based solar panel follower system to follow the trajectory of the sun.

Study design: This research initiative aims to design, simulate, and implement an automatic solar panel tracking system using microcontroller and light sensors and thus to ensure that the environment is clean and safe to combat the climate change effect. This is especially significant in locations where the amount of sunshine varies during the day.

Place and Duration of Study: Department of Electrical and Electronic Engineering, American International University-Bangladesh (AIUB), Dhaka, Bangladesh between January 2023 and July 2023.

Methodology: In this research effort, we used an Arduino Uno microcontroller, servo motor, LDR Sensor, LEDs, solar photovoltaic panel, etc. to make the proposed system. Arduino IDE was used for the program development. The microcontroller controls a servo motor to drive the solar panel from east to west to follow the sun's path in the same direction.

Results: The simulation results and hardware output confirm its functionality.

Conclusion: This design has the potential to drastically cut energy costs and increase the use of renewable energy sources by augmenting the efficacy of photovoltaic systems through the use of a microcontroller-driven single-axis solar tracker, thus contributing to a more sustainable future. This can be scaled up in the future.

Keywords: Solar Panel, Microcontroller, LDR, Servo Motor, CSP, Bifacial, Renewable Energy.

1. INTRODUCTION

The solar photovoltaic system assists in switching to a more sustainable, ecological, and renewable energy system for the future. It is a clean, dependable, and increasingly cost-competitive energy source with the potential to drastically cut greenhouse gas emissions and reliance on fossil fuels. The process of turning sunlight into electrical energy using photovoltaic (PV) cells is referred to as solar photovoltaic production. PV cells are constructed of layers of semiconductor materials, such as silicon, that absorb photons from sunlight and emit electrons, which are subsequently collected and utilized to create energy. The quantity of power that a solar PV system can create is obtained by numerous parameters, including the size and efficiency of the PV cells, the amount of sunlight available, and the orientation and angle of the solar panels [2]. Solar trackers are mechanisms that follow the sun's movement throughout the day, ensuring that solar panels

are constantly pointed squarely at the sun. This improves the quantity of sunshine received by the panels, resulting in increased energy output. Solar PV systems are frequently equipped with tracking devices that watch the passage of the sun throughout the day and modify the angle and orientation of the solar panels accordingly. A solar panel can convert only 18 to 20% of the solar ray that falls on it. When operating a solar photovoltaic (SPV) electricity production system on its own, the SPV boards are often placed on the roof of a building or a mechanical erection at a specific inclined angle [2]. This kind of structure has some limitations as the set-up is stand-still. It cannot track and move concerning the solar irradiation which is not ideal for optimal production and continued production throughout the time is not possible for this kind of setup. The solar photovoltaic boards fitted with a sun tracking device enrich the solar emission acknowledged by the panels and direct the panels toward the sun [2].

This research work aims to design a solar tracker system that will track the solar irradiation and instruct the servo attached to the SPV panel to tilt at a certain angle enabling the panel to maximize photovoltaic production. This report will discuss the design parameters and modeling of this system, compare the simulated and experimental results, and conclude with some future endeavors that can be taken for the betterment of the designed system.

2. LITERATURE REVIEW

At present, many popular and essential systems use microcontroller systems to make our lives comfortable and cost-effective. Such systems range from biomedical, health, commercial manufacturing, pisciculture, obstacle detection, education and training, firefighting, and hazardous scheme design and implementation [3-12].

Solar photovoltaic panels generate electricity by directly converting sunlight into electrical energy using photovoltaic (PV) cells. The method of turning sunbeams into electrical energy that happens in solar panels (PV panels) is known as photovoltaic (PV). The PV panels are not a new invention, attempts to increase their performance remain a major focus for academics and business [13]. An active tracker was employed in the proposed sun tracker system to allow the SPV panel to correctly aim toward the sun. In this scenario, a light-dependent resistor (LDR) is employed as a light-sensing device to make a live sun follower.

The main processing unit of the project is a microcontroller (Arduino R3 board) which differentiates the LDR voltages and commands the servo to tilt at a certain angle to maximize photovoltaic production. The system's primary board has a microprocessor with several power supplies, multiple extension connections, an LED, and a piezoelectric speaker. A board with pushbuttons and some LEDs for a wide range of basic digital operations and a serial-USB interface board using the FTDI FT232R were made. The serial board is well-suited with a wide range of low-cost commercial adapters to eliminate the hassle of soldering small components [14]. The microcontroller used is a single-chip microcomputer that consists of a CPU core, memory, and programmable input/output peripherals on a single chip. Microcontrollers are frequently employed in a wide range of automatically regulated goods and equipment [15].

The analog input ports of a microcontroller allow it to receive analog signals from peripherals connected to it, ranging from various switches and sensors (such as thermal, light, moisture, position, motion, etc.). Analog signals, as opposed to digital signals, which have just two states (such as HIGH or LOW), contain a continuous range of values that can vary between a minimum and maximum value. When an analog signal is applied to a microcontroller's analog input pin, the microcontroller employs an analog-to-digital converter (ADC) to alter the analog signal into digital data to be compatible for processing by the microcontroller. The ADC takes regular samples of the analog signal and turns each sample into a digital value. Once the analog signal has been transformed into a digital value, the microcontroller may use software to process it. The microcontroller, for example, can compare the digital value to

a threshold to initiate an action or utilize the value in a computation. The code in the program then controls the devices or components coupled to the output pins of the microcontroller. The most common actuators for sun tracker systems are servo and stepper motors. The servo motor may control the SPV board to track the sun's movement and guide the SPV board to the sunbeam. The drive mechanism is activated by sending the Pulse Width Modulate (PWM) signals to the servo motor from the microcontroller [2].

The microprocessor controls the servo motor. The microcontroller is designed to read the position sensor readings and compute the sun's location based on this information. The solar panel is then attached to the servo motor, which is used to alter its position to monitor the sun's movement. The microprocessor delivers control impulses to the servo motor that spins the solar panel board according to the movement of the sun.

3. DESCRIPTION OF THE METHODOLOGY AND MODELING

The primary motive is to create a high-quality solar tracker. The system consists of two Light Dependent Resistors (LDR), some resistors, a microcontroller (Arduino Uno R3 Board), and a DC servo motor to utilize the intended working method for ensuring optimal photovoltaic production. The SPV panel is attached to the shafts of the servo motors so that it can follow it. A code is written in Arduino's Integrated Development Environment (IDE) to get the proper output from the microcontroller for optimal energy production. The concept is illustrated in the block diagram representation of the expected system in Fig. 1.

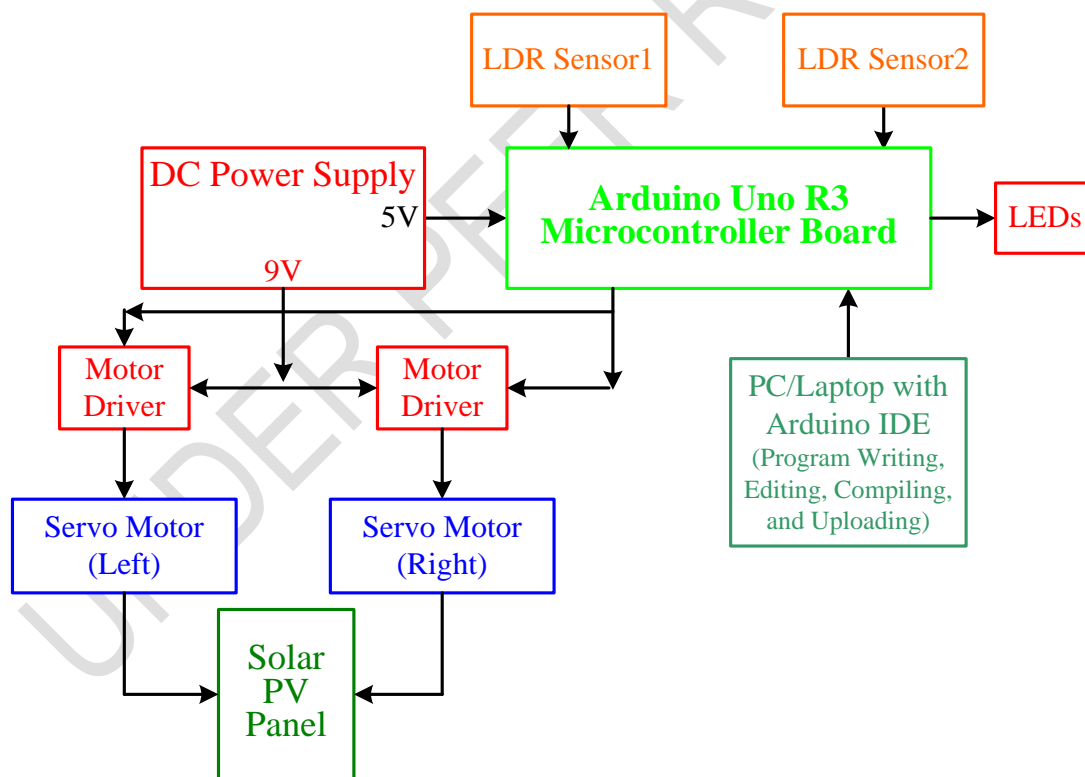

Fig.1. Block diagram of the proposed system

The two LDR sensors are used to measure the light intensity and create a potential difference accordingly. The LDRs are connected to the analog inputs(A0 and A1 pins) of the Arduino Uno microcontroller. According to the light intensity, the LDR sensor can generate the analog output voltage across the resistor connected in series with it [16-17].

A specific operational Arduino code is generated to set some conditions that will compare the values provided by the LDR and act accordingly. When the values of LDR 1 and LDR 2 are the same, the servo will not rotate and hence the solar panel will remain still at an angle where the solar irradiation on both the LDRs and the analog voltages of the LDRs are equal. When the voltage of LDR1 is greater than the voltage of LDR 2, the servo motor will rotate clockwise by decreasing its shaft's angle of rotation. On the other hand, when the voltage of LDR2 is greater than the voltage of LDR 1, the servo motor will rotate anti-clockwise by increasing its shaft's angle of rotation. The flowchart of the planned scheme is revealed in Fig. 2.

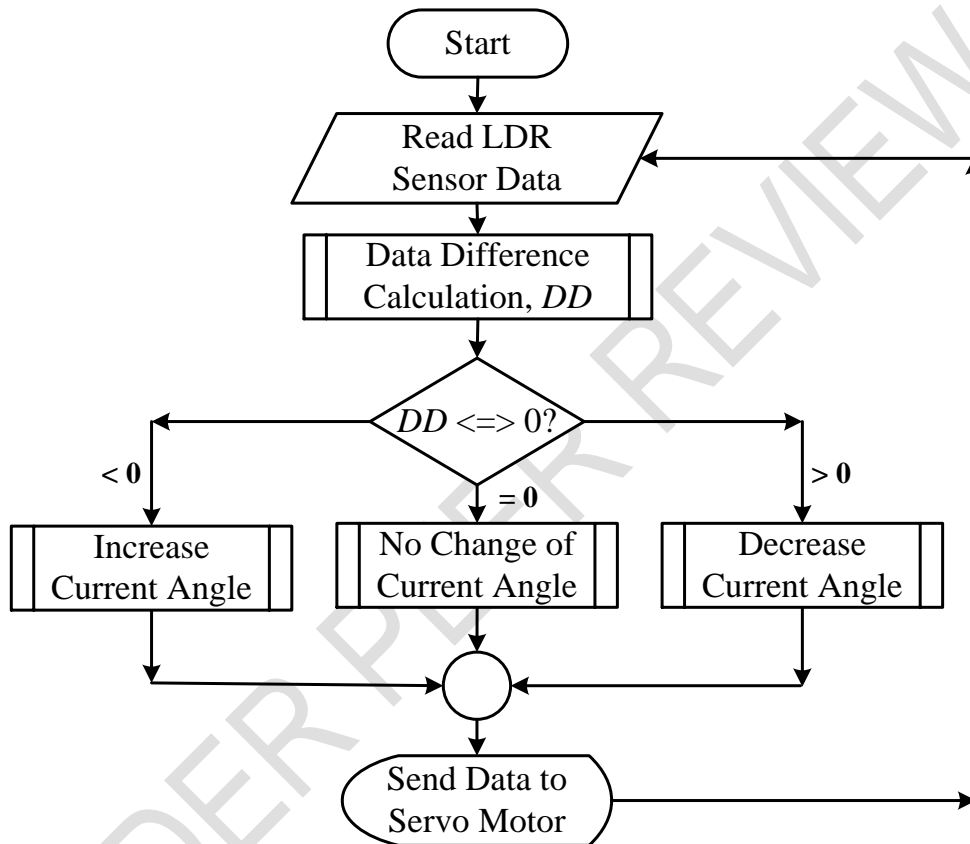

Fig.2. Flow chart of the program for the proposed system

This code is an Arduino program that creates a solar tracker by combining a servo motor and two Light-Dependent Resistors (LDRs). The LDRs detect the sun's position, and the difference between the values is computed to determine if the solar panel's position has to be altered. The servo motor position is then written using the `servo.write()` command with the updated angle of rotation as its argument, and the loop continues after an 80-millisecond pause before repeating the operation. The system may maximize the amount of solar energy gathered by continually shifting the location of the solar panel to face the sun, resulting in enhanced efficiency and power production.

The required components for the proposed system are as follows:

1. Arduino Uno R3 Board
2. Arduino IDE (to write the code for Arduino)
3. Light Dependent Resistors (LDR)
4. Resistors (100 Ω)
5. PWM servo Motor

6. Connecting wires

Each of the components has its contribution to the designed system that was explained in earlier works [16-17]. For simulation, we used the Proteus simulator. Some external library functions were used, such as Arduino Uno R3 library, LDR sensor library, SPI library, etc. The experimental set-up of the planned scheme is given in Fig. 3.

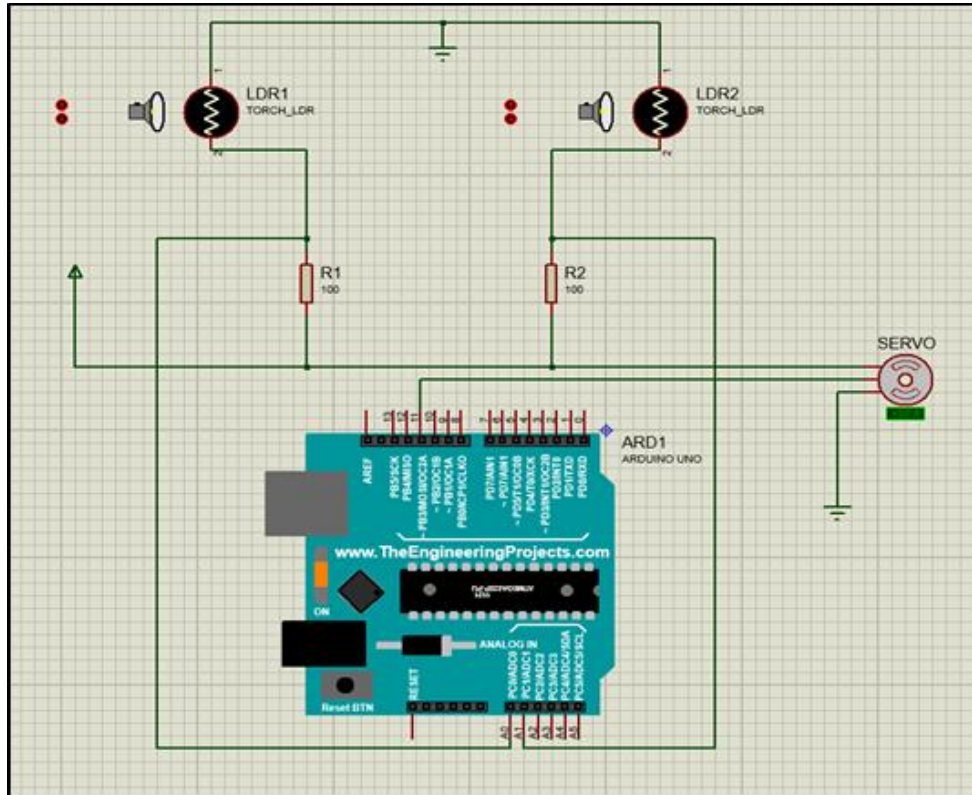

Fig.3. Experimental setup of the proposed system

4. RESULTS AND DISCUSSIONS

4.1 Simulation Results-The system was created in the Proteus simulation environment to simulate the system at its every stage of development. The code was compiled in the IDE and its binary file was utilized in the simulator to observe the simulation outcomes of the designed system. If needed, necessary changes were brought to the code. The simulation outcomes of three different stages are depicted in Figs. 4-6.

The simulation of the circuit was done before making the prototype system at various sun conditions. It is observed that the simulators responded the way it was designed to do so. When the light intensity or solar irradiation was higher on the LDR1, the SPV panel attached to the servo motor rotated clockwise. It rotated in the clockwise direction until the voltages of both the LDRs became equal. This condition is exposed in Fig. 4.

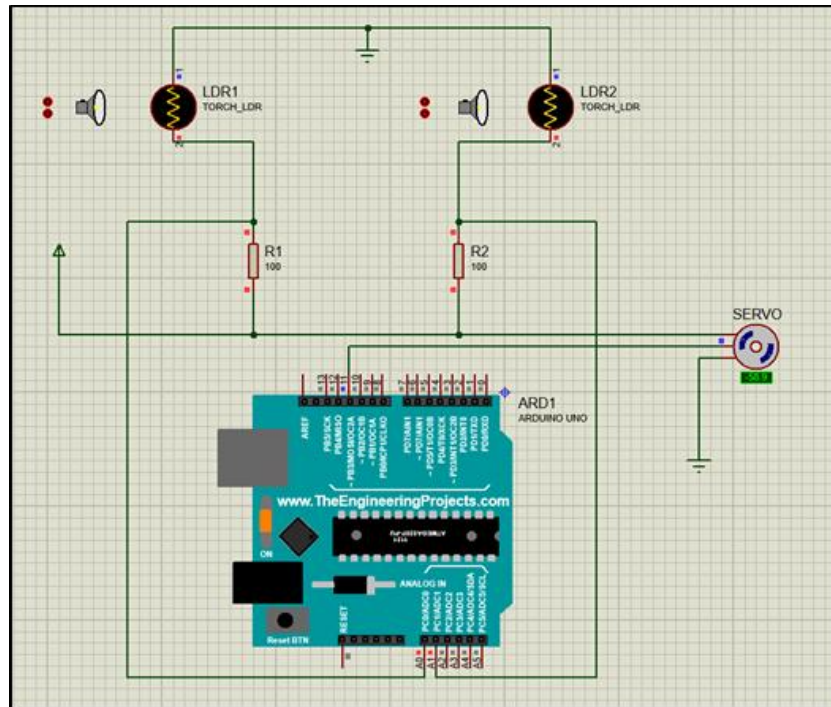

Fig.4. The servo motor rotates in the clockwise direction

When the light intensity or solar irradiation was higher on the LDR 2, the SPV panel attached to the servo motor revolved in an anti-clockwise path. It rotated in the anti-clockwise path until the voltages of both the LDRs became equal. The simulation outcome of this condition is shown in Fig. 5.

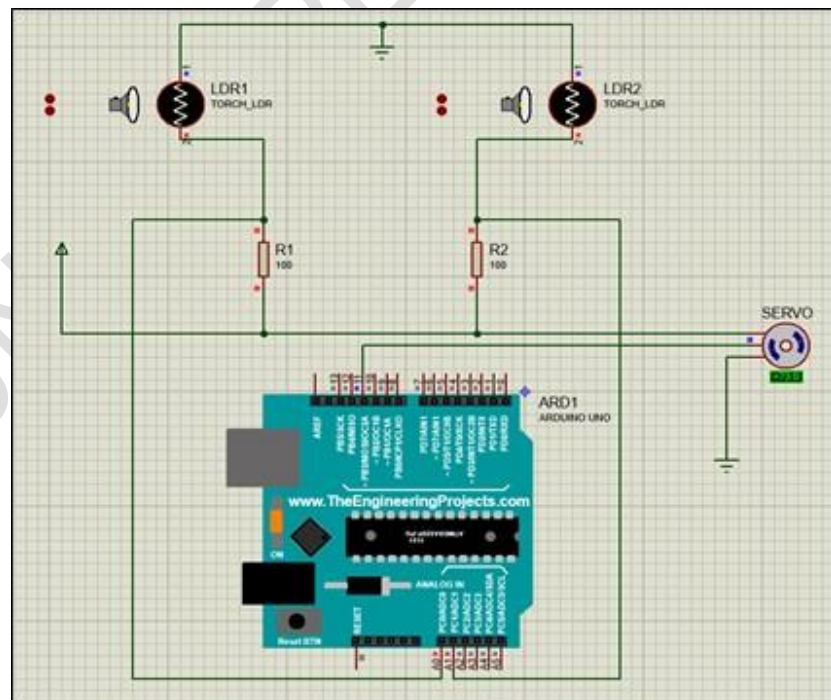

Fig.5. The servo motor rotates in the anti-clockwise direction

When the light intensity or solar irradiation was the same on both the LDR sensors, the SPV panel attached to the servo motor did not rotate in direction because there was no analog voltage difference between the two sensors' outputs. The simulation outcome of this condition is shown in Fig. 6.

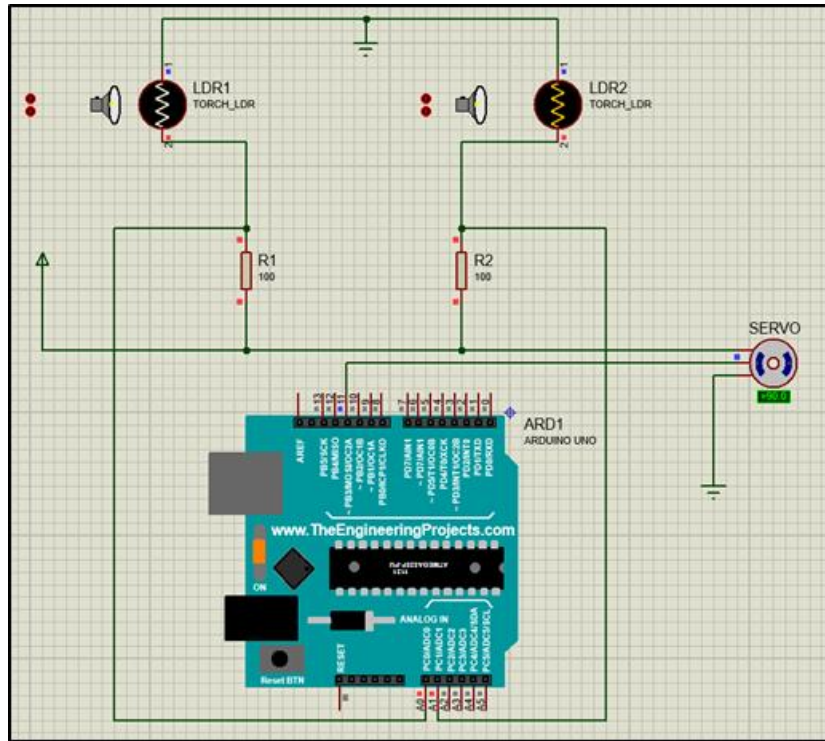

Fig.6. The servo motor does not rotate in either direction

4.2 Experimental Outcomes- To demonstrate the hardware circuit of the single-axis solar tracker constructed using the components mentioned in the modeling section; a prototype of the system has been developed. Then the test run of the system was performed for the same conditions as this prototype and the outcomes are shown in Figs. 7-9.

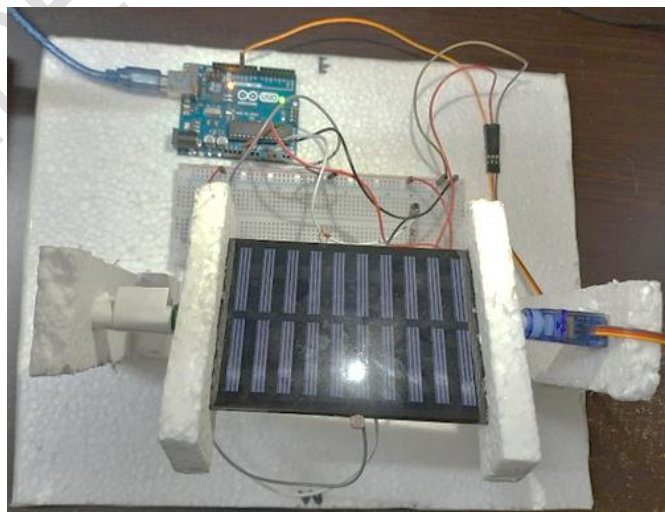

Fig.7. The servo motor rotates in the anti-clockwise direction

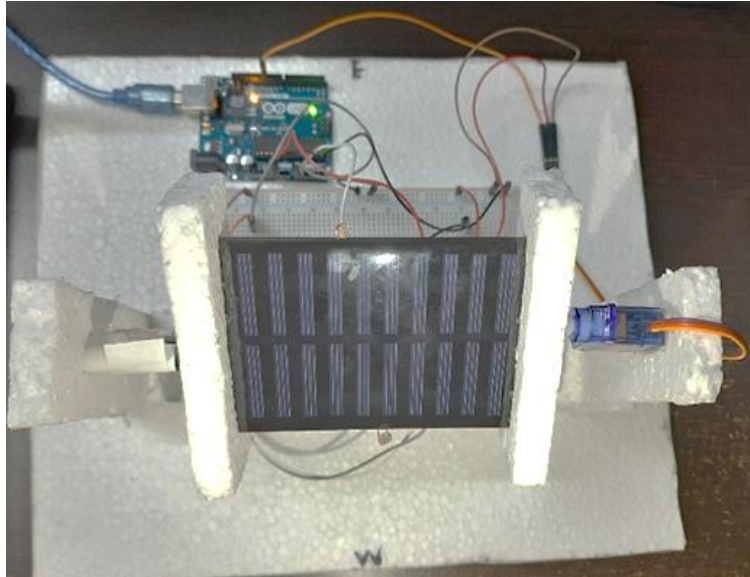

Fig.8. The servo motor rotates in the anti-clockwise direction

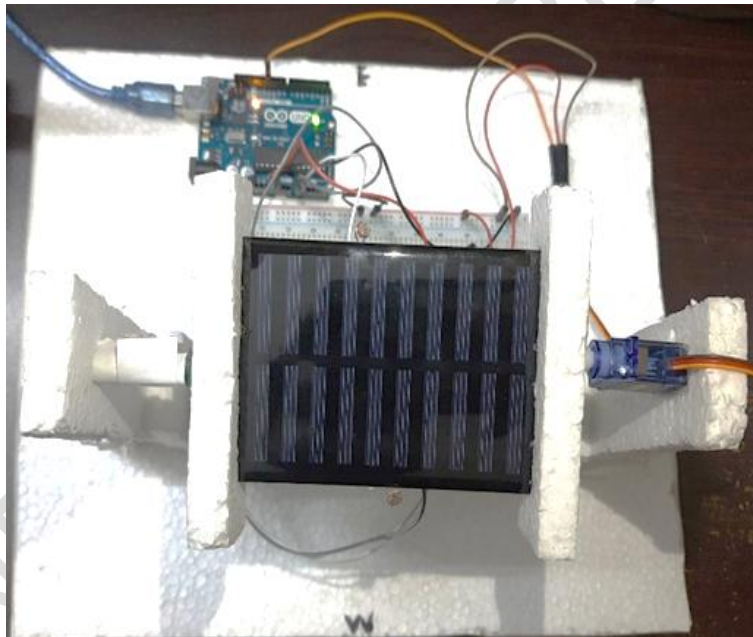

Fig.9. The servo motor rotates in the anti-clockwise direction

4.3 Cost Analysis-After designing the system, the necessary components were chosen for hardware implementation. The components were bought from online electronic stores. As the design was flawless, the circuit connections were constructed with no errors. The cost of the components used in this work is given in Table 1. The developed hardware system is a model prototype, the cost may be higher and lower when we go for the mass-scale production for the actual deployment of the system and as such we may be required to scale up this prototype system. We found that the total manufacturing cost requirement for the prototype design is approximately BDT1,686.00 (that is, approximately one thousand, six hundred and eighty-six Bangladeshi taka only), which is equivalent to US\$14 (the US Dollar fourteen only), approximately.

Table 1. Cost analysis of the design

Equipment	Quantity (pcs)	Cost (BDT)
Arduino Uno R3 Board	1	790.5
LDR	2	12.44
10 kΩ Resistor	2	3.20
Jumper wires	20	52.6
Breadboard	1	130.90
Solar Panel (5 V, 30 mA)	1	236.29
Servo Motor	1	459.9
Total Amount (BDT)		1685.83

There were no defective components, all of the components worked completely fine. However, features could be added to make this system suitable for more enhanced operation. Such as, instead of making it a single-axis tracker it can be made dual-axis to get the maximum solar irradiation from all the directions. This improves solar tracking accuracy and can enhance the energy output further. A noteworthy limitation of this system is that it is pretty much weather-dependent. Solar tracking may be optimized using advanced control algorithms that take into consideration elements, such as cloud cover, shade, and meteorological conditions. Bifacial solar panels can be used that can absorb sunlight from both sides, allowing them to generate more electricity when installed on a solar tracker. Combining a single-axis solar tracker with bifacial solar panels can increase energy output further.

4.4 Limitations -Here are some potential limitations of a solar tracking system using Arduino:

- (a) Accuracy: The precision of the sensors utilized and the control algorithm may restrict the tracking system's accuracy. Small errors in the sun's position can add up over time, resulting in a significant deviation from the optimal position.
- (b) Power consumption: The usage of servo motors to modify the position of the solar panel may use a large amount of electricity, lowering the solar panel's efficiency. Furthermore, the Arduino itself may consume a significant amount of power, especially if it is continuously running.
- (c) Cost: Implementing a sun-tracking system with Arduino might be expensive, especially if high-quality sensors and motors are employed.
- (d) Maintenance: The system may require frequent maintenance to guarantee proper operation, such as sensor and motor calibration and the replacement of any malfunctioning components.
- (e) Durability: The system may be subjected to adverse weather conditions such as excessive heat or wetness, which might harm the electronics or shorten the system's lifespan.
- (f) Compatibility: The system may not be suitable with all types of solar panels, particularly if the panel design prevents convenient installation and movement.

Solar panels can grow filthy over time, reducing their effectiveness. The panels may be kept clean and working at optimal efficiency by attaching a cleaning system to the solar tracker, such as a brush or spray nozzle. Nonetheless, adding more features will eventually increase the cost of the product. Therefore, keeping every prospect in mind, the proposed system is pretty efficient.

7. CONCLUSIONS

Due to enhanced direct exposure to sun rays, SPV panels with trackers generate more power than stationary equivalents. Solar panels with solar trackers are often better than

stationary solar panels because they can gather more sun energy. Stationary solar panels are set in place and, depending on their direction and the time of day, can only catch a part of the available sunlight. Solar panels with solar trackers, on the other hand, can detect the trajectory of the sun all day long, allowing them to stay in perfect alignment and catch the most amount of sunlight possible. Solar trackers can enhance the aggregate of energy created by stationary solar panel boards by up to 22 to 25% by continually shifting the placement of the solar panel to face the sun. This enhanced efficiency and power production can be especially advantageous in places with limited sunshine or space, allowing more energy to be generated from the same amount of solar panel surface.

Solar panels with solar trackers, on the other hand, are often more costly and require more maintenance than stationary solar panels. Solar trackers should be chosen based on a cost-benefit analysis that considers factors such as available sunshine, space constraints, and budget. In the future, more projects like this can be done such as the dual axis solar tracker, concentrated solar power (CSP) which concentrates sunlight into a tiny area, generating heat that may be utilized to create electricity, solar-powered water desalination which can be used to convert saltwater into drinking water using solar energy, etc. Nonetheless, based on this project, it can be concluded that the already developed microcontroller-based single-axis solar tracking system is an efficient renewable energy system.

REFERENCES

1. M. S. I. Sadek, M. A. H. Joy, M. K. Islam, M. A. Ananna, M. H. Bhuyan, and M. S. Aktar. Design and Analysis of a Rooftop Hybrid Solar PV System using Homer Pro and MATLAB Simulink. Southeast University Journal of Electrical and Electronic Engineering (SEUJEEE), ISSN: p-2710-2149, e-2710-2130, vol. 2, issue 1, January 2022, pp. 35-45.
2. I. H. Rosma, I. M. Putra, D. Y. Sukma, E. Safrianti, A. A. Zakri and A. Abdulkarim, "Analysis of Single Axis Sun Tracker System to Increase Solar Photovoltaic Energy Production in the Tropics," 2018 2nd International Conference on Electrical Engineering and Informatics (ICon EEI), Batam, Indonesia, 2018, pp. 183-186, doi: 10.1109/ICon-EEI.2018.8784311.
3. M. S. Ali and M. H. Bhuyan, "Design and Implementation of a Low-Cost Blood Pressure Measuring Device," Proceedings of the IEEE International Conference on Electrical and Computer Engineering, Bangladesh University of Engineering and Technology, Dhaka, 20-22 December 2018, pp. 309-312.
4. M. H. Bhuyan and M. Sheikh, "Designing, Implementing, and Testing of a Microcontroller and IoT-based Pulse Oximeter Device," IOSR Journal of Electrical and Electronics Engineering (IOSR-JEEE), ISSN: e-2278-1676, p-2320-3331, vol. 16, issue 5, series-2, September-October 2021, pp. 38-48.
5. M. H. Bhuyan, S. D. Monty and M. R. Z. Sarkar, "Design and Implementation of an NIR-Technique Based Non-Invasive Glucometer using Microcontroller," Journal of Bangladesh Electronics Society, ISSN: 1816-1510, vol. 19, no 1-2, June-December 2019, pp. 75-84.
6. M. H. Bhuyan, M. T. Hasan and H. Iskander, "Low Cost Microcontroller Based ECG Machine," International Journal of Biomedical and Biological Engineering, vol. 14, no. 7, 2020, e-ISSN: 1307-6892, pp. 192-199.
7. M. H. Bhuyan, M. A. Ali, S. A. Khan, M. R. Islam, T. Islam and J. Akter, "Design and Implementation of Solar Power and an IoT-Based Pisciculture Management System," Journal of Engineering Research and Reports, ISSN: 2582-2926, vol. 24, issue 2, Article no. JERR.95811, January 2023, pp. 15-27.
8. A. H. Adnan, M. N. Sadik, A. T. Mamun, T. S. Shefat, and M. H. Bhuyan, "Design, Simulation, and Implementation of a Surveillance Robot System," Proceedings of the International Conference on Electronics and Informatics, Bangladesh Electronics and

- Informatics Society (BEIS), Bangladesh Atomic Energy Center (BAEC), Dhaka, Bangladesh, 26-28 January 2023, p. 98.
9. A. A. Mansur, B. C. Shill, and M. H. Bhuyan. Design and Development of PC-Based Elevator Control Systems via ATmega32 Microcontroller. Southeast University Journal of Science and Engineering (SEUJSE), ISSN: 1999-1630, vol. 10, no. 1, June 2016, pp. 102-107.
 10. R. Titlee and M. H. Bhuyan, "Design, Implementation and Testing of Ultrasonic High Precision Contactless Distance Measurement System Using Microcontroller," Southeast University Journal of Science and Engineering (SEUJSE), ISSN: 1999-1630, vol. 10, no. 2, December 2016, pp. 6-11.
 11. M. K. Russel and M. H. Bhuyan, "Microcontroller Based DC Motor Speed Control Using PWM Technique," Proceedings of the International Conference on Electrical, Computer and Telecommunication Engineering (ICECTE), Rajshahi, Bangladesh, 1-2 December 2012, pp. 519-522.
 12. N. K. Paul, D. Saha, R. T. Islam, M. M. Marufi, S. Akter, and M. H. Bhuyan, "Meta Bin – An Arduino-Based Smart Device for Collecting Trash," Proceedings of the International Conference on Electronics and Informatics, organized by the Bangladesh Electronics and Informatics Society, Bangladesh Atomic Energy Center (BAEC), Dhaka, Bangladesh, 26-28 January 2023, p. 63.
 13. Abadi, I., Musyafa, A., and Soeprijanto, A. Design of single axis solar tracking system at photovoltaic panel using fuzzy logic controller. 5th Brunei International Conference on Engineering and Technology (BICET 2014). doi:10.1049/cp.2014.1086
 14. J. Diz-Bugarín and R. Rodríguez-Paz. Arduino-compatible microcontroller module for electronics practices and environmental monitoring. 2020 XIV Technologies Applied to Electronics Teaching Conference (TAEE), Porto, Portugal, 2020, pp. 1-6, doi: 10.1109/TAEE46915.2020.9163728.
 15. M. Alam, M. A. Dewan, S. S. Bashar, M. S. Miah and A. Ghosh. A Microcontroller Based Dual Axis Tracking System for Solar Panel. 2019 3rd International Conference on Electrical, Computer & Telecommunication Engineering (ICECTE), Rajshahi, Bangladesh, 2019, pp. 25-28, doi: 10.1109/ICECTE48615.2019.9303534.
 16. M. H. Bhuyan and P. K. Saha. Microcomputer-Based Dish Antenna Position Control System with Autocalibration Option. Proceedings of the IEEE International Conference on Computing and Information Technology, Dhaka, 28-30 December 2005, pp. 417-421.
 17. S. Biswas, M. H. Bhuyan, and M. K. Hasan. IoT-based Automated Solar Panel Cleaning and Monitoring Technique. Journal of Engineering Research and Reports, ISSN: 2582-2926, vol. 25, issue 8, Article no. JERR.105650, 2 September 2023, pp. 56-69.