

1
2
3
4
5
8

Optimal Tuning PID Controller Gains from Ziegler-Nichols Approach for An Electrohydraulic Servo System

11
12
13

14 **ABSTRACT**

15 The Proportional-Integral-Derivative (PID) controller is widely used to control industrial systems due to its ease of implementation, flexibility and well-known theory. The Ziegler-Nichols (ZN) method is the primary method of adjusting this gains controller. Unfortunately, this method generates limited performances, especially on nonlinear systems. This paper shows the optimization of the gains of the PID controller from the values of the gains obtained by the ZN method. To do this, the Matlab Response Optimization tool is used to control the angular position of an electrohydraulic servo system. The initial conditions of this optimization process are the gain values adjusted by the ZN method. The numerical results obtained after a few iterations show a reduction of approximately 40% in the tracking error for a sinusoidal input. Unfortunately, the performance improvement is not achieved for the step signal input because only the sine wave was used as the signal reference requirement for the optimization procedure.

16
17 *Keywords: PID control; Electrohydraulic servo system; Matlab response optimization; Ziegler-Nichols method*

18
19 **1. INTRODUCTION**

20
21 The industry uses electro-hydraulic servo systems (EHSS) when it comes to manipulating heavy loads quickly, robustly and precisely. Thus, the EHSS are encountered in the fields of aerospace [1], machine tools [2], handling [3], robot manipulator [4] and automotive active suspension [5]. The EHSSs have an electrical part and a hydraulic operational part. The mechanical load is driven by the hydraulic part using the power transmission of Pascal Law[6]. The control law is implemented in the electric part. It is the electrohydraulic servo valve which ensures the interface between the two parts. The flow dynamics of this servovalve make the modelling of the EHSS strongly nonlinear [6]. Proportional-Integral-Derivative (PID) controller, widely used to control industrial systems, is based on linear systems theory[7] [8]. This control law can be applied to nonlinear systems while guaranteeing satisfactory performances. This controller has three gains to adjust. Most of the time, the Ziegler Nichols approach is used to adjust the tree gains [8]. However, the adjusted gains value with this approach gives significant overshoot with step input and tracking error with sinus input [9] [10]. Cohen Coon is another classical method found in the literature for adjusting PID gains [11] [12]. These two conventional techniques lead to limited performances, especially with nonlinear systems.

32
33
34 Optimization methods for adjusting the gains of the PID controller can be found in the literature to circumvent the conventional methods. Particle Swarm Optimization technique may be used to adjust the PID gains [13, 14]. Artificial Immune System Algorithm is another alternative studied by the researchers [15] [16]. The PID controller is simple to implement, flexible and fairly understood in the industry. The only drawback of its use is the adjustment of these gains in order to obtain satisfactory performance. Most of these optimization techniques make the controller lose simplicity and are

difficult to implement. In this paper, we use a simple procedure to fine-tune the PID controller gains using the response optimization tool in the Matlab Simulink environment. Because the fine-tuning of the results depends on the initial conditions [17], we use the values obtained by the Ziegler Nichols approach as initial conditions of the Matlab optimization tool.

The remainder of the paper is organized as follows: Section 2 describes the mathematical modelling of the EHSS. Section 3 shows the architecture of the PID Controller and the proposed tuning adjustment technique. Section 4 presents the simulation results. Finally, the conclusion is draw in Section 5.

2. MATHEMATICAL MODELLING

The electrohydraulic servo system (EHSS) under study is shown in Fig. 1. The hydraulic oil stored in the atmospheric tank is sent to the servo valve inlet using a positive displacement pump. The pressure relief valve and the accumulator maintain a constant fluid pressure at the inlet of the electrohydraulic servovalve. The servovalve opens a passage for fluid for one of the hydraulic motor's ports based on its electrical input signal. Oil entering one of the hydraulic motor terminals generates a pressure difference in the presence of a mechanical load. When the pressure induced by the load is reached, the hydraulic motor turns driving the load. The actual angular position of the hydraulic motor is sensed via the feedback transducer and then transmitted to the control law whose objective is to ensure that the tracking error between the reference signal and the actual position is minimal.

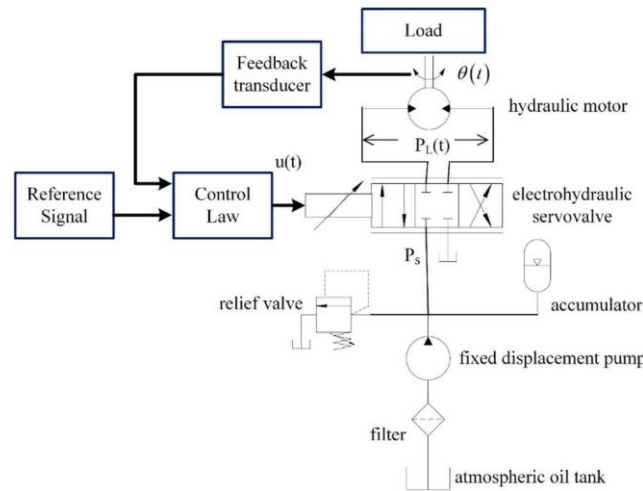

Fig. 1. Electrohydraulic Servo System

The system can therefore be decomposed into four subsystems as shown by the state-space equation (1). The output equation is $y(t) = x_1(t)$. The first subsystem is the relationship existing between the angular position and the angular velocity. The second subsystem describes the dynamics of the mechanical load using the Newton 2nd law. The third subsystem represents the continuity equation across the hydraulic motor; The fourth subsystem describes the relationship between the electrical signal and the fluid passage section in the electrohydraulic servo valve.

$$\begin{aligned}
 \dot{x}_1(t) &= x_2(t) \\
 \dot{x}_2(t) &= \frac{d_m}{J} x_1(t) - \frac{B_m}{J} x_2(t) \\
 \dot{x}_3(t) &= \frac{P - \text{sign}(x_4(t)) x_3(t) - d_m x_2(t) - c_{sm} x_3(t)}{V_m \sqrt{\frac{P}{\rho}}} \\
 \dot{x}_4(t) &= \frac{K}{V} u(t) - \frac{1}{V} x_4(t) \\
 y(t) &= x_1(t)
 \end{aligned} \tag{1}$$

Where

$x_1(t)$ is the angular velocity

$x_2(t)$ is the motor pressure difference due to the load

$x_3(t)$ is the servovalve opening area due to the input signal

71 $u(t)$ is the control current input
 72 J is the hydraulic motor total inertia
 73 d_m is the volumetric displacement of the motor
 74 β is the fluid bulk modulus
 75 V_m is the total oil volume of the hydraulic motor
 76 c_d is the servovalve discharge coefficient
 77 ρ is the fluid mass density
 78 c_{sm} is the leakage coefficient of the hydraulic motor
 79 P_s is the supply pressure at the inlet of the servovalve
 80 K is the servovalve amplifier gain
 81 τ is the servovalve time constant

83 The implementation of the EHSS in the Matlab Simulink environment is shown in the Figure 2.
 84

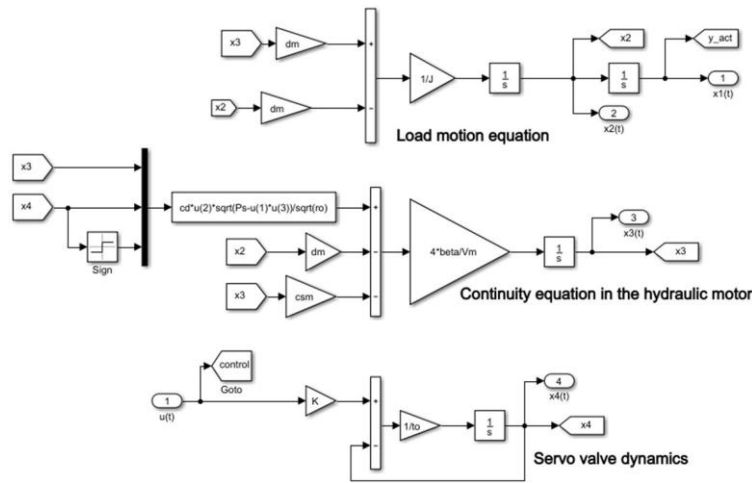

Fig. 2. Matlab/ Simulink block diagram of the EHSS

3. CONTROLLER DESIGN

In this section, the proportional integral and derivative controller is developed. We start by presenting its architecture then we show the proposed gains tuning method.

3.1 PID Controller architecture

The architecture of the PID control law $u_{PID}(t)$ is shown in Equation (2) where $y_{des}(t)$, $y_{act}(t)$ and $e(t)$ are the desired output, the actual output and the tracking error respectively. This control law gives three actions to the feedback tracking error to improve the closed-loop performances[18]. The first action is the proportional action to provide fast and strong control correction. The second action is the integral control effort aimed at taking into account errors accumulated in the past. The third term is the derivative action. It consists of anticipating the control correction.

$$u_{PID}(t) = k_p \left(y_{des}(t) - y_{act}(t) \right) + k_i \int \left(y_{des}(t) - y_{act}(t) \right) dt + k_d \frac{d \left(y_{des}(t) - y_{act}(t) \right)}{dt} \quad (2)$$

Where k_p , k_i and k_d are the proportional gain, the integral gain and the derivative gain respectively. The implementation of the PID controller in the Matlab/ Simulink environment is shown in Figure 3.

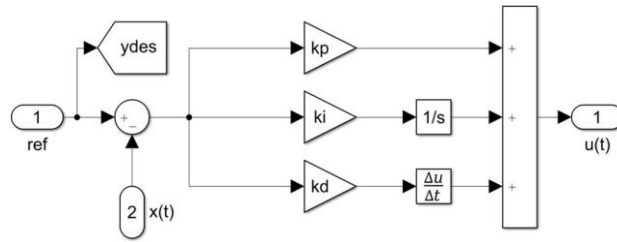

Fig. 3. Matlab/ Simulink block diagram of the PID controller

3.2 Gains tuning technique

The proposed technique for adjusting the three gains of the PID controller consists of two parts. The first part is to obtain the gains values using the classical Ziegler-Nichols approach with ultimate gain and oscillation period [19]. The second part allows to refine the adjustment of the gains using the response optimization tool (ROT) in the Matlab/ Simulink environment. The values obtained with the ZN approach are used as initial conditions in the ROT. Figure 4 shows the recording of these initial values in the ROT. Figure 5 shows the control design requirement that the output tracks the reference signal. Here, we choose a sine wave as a reference signal requirement. Figure 6 shows the progress of the response optimization report with its iterations.

Variable	Value	Minimum	Maximum	Scale
<input checked="" type="checkbox"/> ki	7.2	0	Inf	1
<input checked="" type="checkbox"/> kp	0.54	0	Inf	1
<input checked="" type="checkbox"/> kd	0.0101	0	Inf	1

Variable	Current val...	Used By
entree	1	EHSS_ARTICLE_8/Sine Wave
kdz	0.01012500...	EHSS_ARTICLE_8/PID_ZIEGLER_NICHOLS_TUNING/Gain
kiz	7.199999999...	EHSS_ARTICLE_8/PID_ZIEGLER_NICHOLS_TUNING/Gain1
kpz	0.54	EHSS_ARTICLE_8/PID_ZIEGLER_NICHOLS_TUNING/Gain2
ro	900	EHSS_ARTICLE_8/EHSS/Fcn
s	7	EHSS_ARTICLE_8/EHSS/Saturation

Fig. 4. Initial values and gain variables set

Create Requirement

Signal Tracking
Specify a tracking requirement on a signal.

Name:

▼ Specify Reference Signal

Time vector:

Amplitude:

Tracking Method:

Use robust cost

▼ Specify Signal to Track Reference Signal

Signal
<input checked="" type="checkbox"/> Sig (EHSS_ARTICLE_8/EHSS:1)

Create Plot

Fig. 5. Requirement on the response optimization

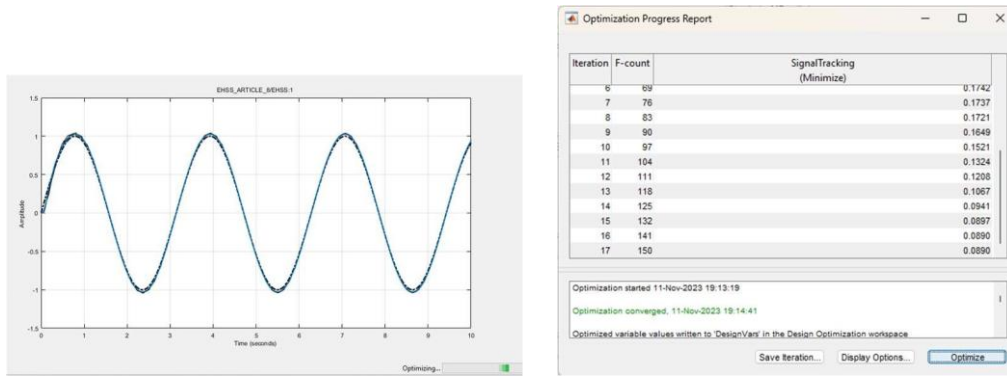

Fig. 6. Optimization procedure and iterations report

4. NUMERICAL RESULTS

This section presents the performances obtained with the PID controller where the gains are tuned using the response optimization tool. We compare the results with the PID controller where the gains are obtained using the classical ZN approach. The numerical values used for the simulation are listed in the Table 1. The values of the tree gains of the PID controllers are shown in the tables 2 and 3.

Table 1. EHSS numerical values

Description	Value and units
	0.01s
Servo valve amplifier gain	$8 \cdot 10^{-7} \text{ m}^2/\text{mA}$
Volume of the hydraulic motor	$3 \cdot 10^{-4} \text{ m}^3$
Fluid bulk modulus	$8 \cdot 10^8 \text{ Pa}$
Flow discharge coefficient	0.61
Supply pressure	$9 \cdot 10^6 \text{ Pa}$
Leakage coefficient	$9 \cdot 10^{-13} \text{ m}^5/(\text{N.s})$
Volumetric displacement	$3 \cdot 10^{-6} \text{ m}^3/\text{rad}$
Fluid mass density	900 kg/m^3
Inertia of the hydraulic motor	0.05 N.m.s^2
Viscous damping coefficient	0.2 N.m.s

Table 2. Values of the PID controller gains obtained with Ziegler-Nichols approach

Gains	Value
	0.54
	7.2
k_d	0.0101

Table 3. Values of the PID controller gains obtained with Response optimization tool

Gains	Value
	0.76
	41.67
k_d	0.031

Figure 7 shows the implementation of the closed-loop system in the Matlab/ Simulink environment. Two reference signals are used to perform the simulation and represent the desired angular position. The first reference signal is a step input with an amplitude of 1 rad. The second reference signal is a sine wave of amplitude 1 rad and frequency of 2 Hz. The simulation lasts 10 seconds and the sampling time is 0.01 second.

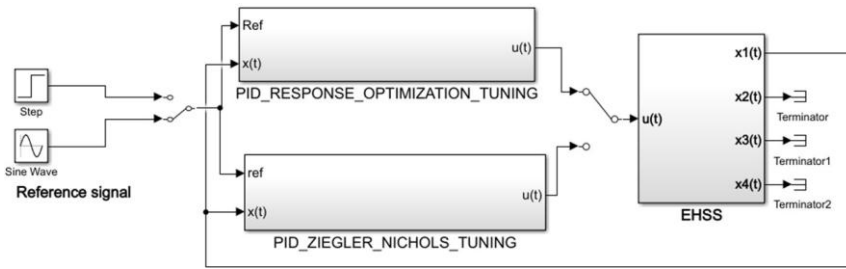

Fig. 7. Closed-loop block diagram of the controlled EHSS

Figure 8 shows the closed-loop responses obtained when using the PID controller with conventional Z-N tuning. As expected, a significant overshoot is visible in the step response. A tracking error is visible in the sinusoidal response. Figure 9 shows the closed-loop responses when using the RO-PID controller. Because we use the sinusoidal wave as the reference requirement, we reduce the tracking error in the closed-loop response. As shown in Figure 10, the tracking error with the RO-PID controller is smaller than the tracking error obtained with the ZN-PID controller. However, the values of these optimized gains lead the closed-loop system to instability when the input is a step signal.

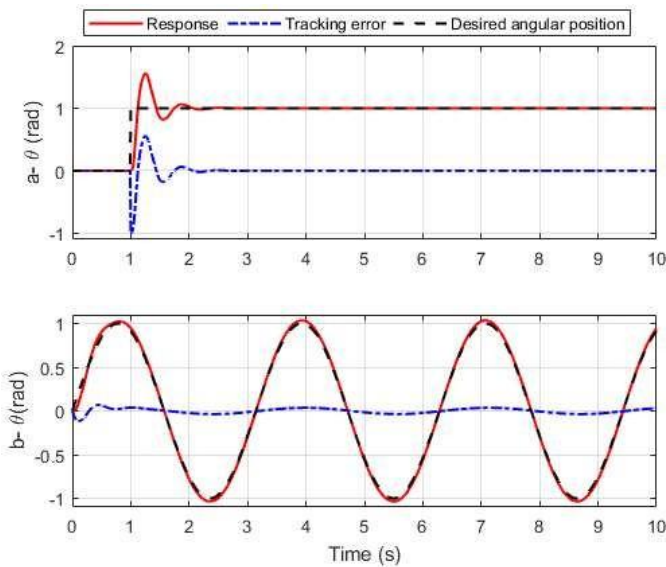

Fig. 8. Closed-loop responses when using the classical ZN-PID controller: a- step response b- sinusoidal response

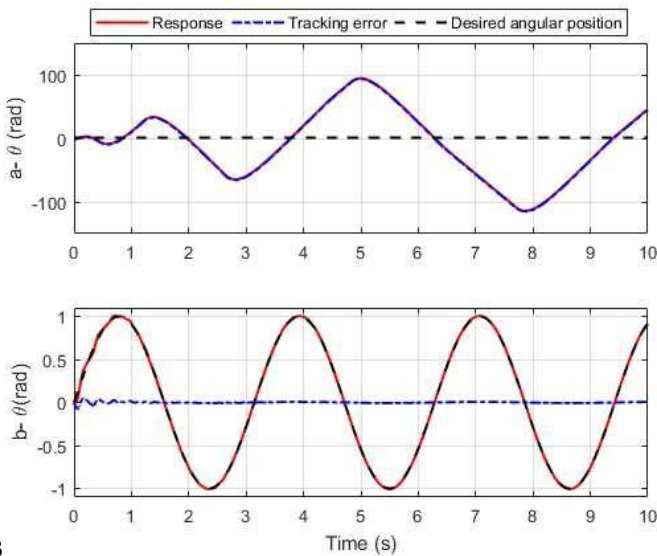

Fig. 9. Closed-loop responses when using the RO-PID controller: a- step response b- sinusoidal response

156
157
158
159

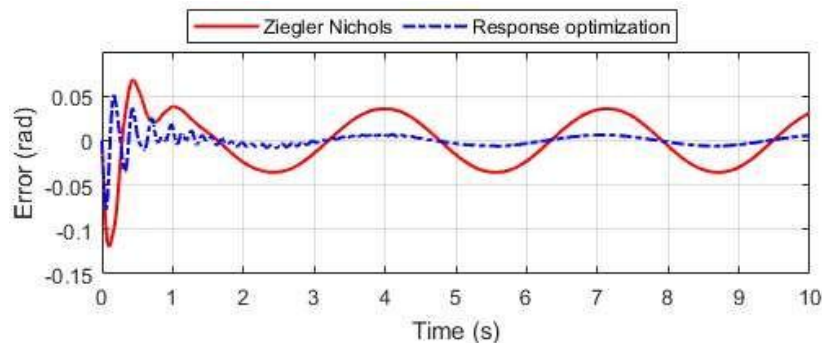

Fig. 10. Tracking error of the two controllers when sinusoidal input

160
161

4. CONCLUSION

162
163
164

This paper presents a simple method for finely adjusting the three gains of the angular position PID controller of an electrohydraulic servosystem. The proposed method combines the classic Ziegler Nichols approach with the Matlab/Simulink optimization tool. Indeed, it has been found that the choice of initial conditions significantly affects the precision of the results in optimization techniques. It is in this perspective that the gain values obtained with the Ziegler Nichols approach are used as initial values in the proposed optimization procedure. The numerical results show a tracking error reduction of approximately 40% for the input types used during the optimization procedure. Future work will involve experimental results.

171
172
173
174

COMPETING INTERESTS

Authors have declared that no competing interests exist.

175
176
177

AUTHORS' CONTRIBUTIONS

Gérémino Ella Eny and Honorine Angue Mintsas designed the study, wrote the protocol and wrote the manuscript. Nzamba Senouveau and Rolland Michel Assoumou Nzué performed the statistical analysis of the study.

181
182
183
184

REFERENCES

185
186
187

- [1] S. Zhao *et al.*, "A Generalized Control Model and Its Digital Algorithm for Aerospace Electrohydraulic Actuators," in *Proceedings*, 2020, vol. 64, no. 1, p. 31: MDPI.
- [2] S. Li *et al.*, "Failure analysis for hydraulic system of heavy-duty machine tool with incomplete failure data," *Applied Sciences*, vol. 11, no. 3, p. 1249, 2021.
- [3] D. T. Tran, D. X. Ba, and K. K. Ahn, "Adaptive backstepping sliding mode control for equilibrium position tracking of an electrohydraulic elastic manipulator," *IEEE Transactions on Industrial Electronics*, vol. 67, no. 5, pp. 3860-3869, 2019.
- [4] W.-H. Zhu and J.-C. Piedboeuf, "Adaptive output force tracking control of hydraulic cylinders with applications to robot manipulators," *Dynamic Systems, Measurement and Control*, vol. 127, no. 2, pp. 206-217, 2005.
- [5] A. M. Al Aela, J.-P. Kenne, and H. Angue Mintsas, "Adaptive neural network and nonlinear electrohydraulic active suspension control system," *Journal of Vibration and Control*, vol. 28, no. 3-4, pp. 243-259, 2022.
- [6] H. E. Merritt, *Hydraulic Control Systems*. John Wiley & Sons Inc, 1967.
- [7] F. Alarçin, H. Demirel, M. E. Su, and A. J. A. P. H. Yurtseven, "Conventional PID and modified PID controller design for roll fin electro-hydraulic actuator," *Acta Polytechnica Hungarica*, vol. 11, no. 3, pp. 233-248, 2014.

200
201

- 202 [8] V. V. J. R. Patel, "Ziegler-Nichols Tuning Method: Understanding the PID Controller," *Resonance*, vol.
203 25, no. 10, pp. 1385-1397, 2020.
- 204 [9] O. A. Somefun, K. Akingbade, and F. Dahunsi, "The dilemma of PID tuning," *Annual Reviews in Control*,
205 vol. 52, pp. 65-74, 2021/01/01/ 2021.
- 206 [10] C. M. Shern, R. Ghazali, C. S. Horng, C. C. Soon, H. I. Jaafar, and T. Sciences, "Optimization techniques
207 in PID controller on a nonlinear electro-hydraulic actuator system," *Journal of Advanced Research in*
208 *Fluid Mechanics*, vol. 56, no. 2, pp. 296-303, 2019.
- 209 [11] A. Utami, R. Yuniar, A. Giyantara, and A. Saputra, "Cohen-Coon PID Tuning Method for Self-Balancing
210 Robot," in *2022 International Symposium on Electronics and Smart Devices (ISESD)*, 2022, pp. 1-5:
211 IEEE.
- 212 [12] J. Hao, G. Zhang, D. Zhu, and H. Ye, "High Efficiency Data Driven Control Based on Dynamic
213 Linearization and PIDNN With Cohen-Coon for Discrete Nonlinear Fast Time-Varying Systems," *IEEE*
214 *Transactions on Circuits Systems II: Express Briefs*, 2023.
- 215 [13] H. Feng, W. Ma, C. Yin, and D. Cao, "Trajectory control of electro-hydraulic position servo system using
216 improved PSO-PID controller," *Automation in Construction*, vol. 127, p. 103722, 2021/07/01/ 2021.
- 217 [14] Z. Xiang, D. Ji, H. Zhang, H. Wu, and Y. J. I. S. Li, "A simple PID-based strategy for particle swarm
218 optimization algorithm," *Information Sciences*, vol. 502, pp. 558-574, 2019.
- 219 [15] T. Tashan, E. H. Karam, and E. F. Mohsin, "Immune PID controller based on differential evolution
220 algorithm for heart rate regulation," *International Journal of Advanced Computer Research*, vol. 9, no. 42,
221 pp. 177-185, 2019.
- 222 [16] M. Çınar and Control, "Optimal tuning of a PID controller using a wound healing algorithm based on the
223 clonal selection principle," *Transactions of the Institute of Measurement and Control*, vol. 44, no. 9, pp.
224 1770-1776, 2022.
- 225 [17] B. Kizielewicz and W. Sałabun, "A new approach to identifying a multi-criteria decision model based on
226 stochastic optimization techniques," *Symmetry*, vol. 12, no. 9, p. 1551, 2020.
- 227 [18] D. Gray, "CHAPTER 10 - The Basic Principles of Automatic Controllers," in *Centralized and Automatic*
228 *Controls in Ships*, D. Gray, Ed.: Pergamon, 1966, pp. 120-144.
- 229 [19] K. Ogata, *Modern control engineering* (no. 1181). Pearson, 1999, p. 1184.
- 230