

# Proposal of application of a simple analysis code DYMOS for accident analyses of molten salt reactors

---

## Abstract

The Molten Salt Reactor (MSR) possesses unique characteristics, including the circulation of liquid fuel salt in-core and ex-core, and the absence of cladding tubes of fuel rods. To perform safety analyses for accidents and transients, the selection of appropriate models is crucial. Proposed models vary from the coupling of a three-dimensional (3-D) nuclear reactor model and a detailed thermal/hydraulic (T/H) model to a simple point reactor model coupled with a lumped parameter model of the T/H system. The authors have been investigating the development of a simple and accurate model that can be utilized during the design stage and licensing evaluation, while also providing transparency, which means that models can be easily understandable by experts and reproduced in licensing evaluation.

Given the distinctive features of the MSR, the peak heat flux or fuel cladding peak temperature is not a requirement. Instead, the most decisive parameter for safety evaluations is the fuel salt temperature in the fuel salt boundary. As demonstrated in this paper, the outlet of the MSR core consistently displays the highest temperature.

Based on the afore-mentioned prospects for both nuclear and T/H systems, the authors have developed a simple safety and transient analysis code for MSR (DYMOS). The DYMOS code has been verified for MSRE experiments, as described in this paper. However, the previous verification was limited to small experimental MSRs, and there is a lack of verification for large reactor systems. This paper presents information indicating that the DYMOS code is applicable to these larger reactors. In other words, the main objective of this article is not to claim the originality of the model of DYMOS code, but to propose applicability of such simple code to large reactor systems.

**Keywords:** molten salt reactors, MSR, accident analysis, DYMOS code, reactivity initiated accident, loss of flow accident.

**Comment [VL1]:** Give your final result of the experiment

## 1. Introduction

Recently, efforts to develop molten salt reactors (MSR) have been in progress in many countries [1, 2]. One of these activities is to perform safety analyses for accidents and transients, which is indispensable for MSR design and licensing. For these purposes, many analytical codes have been proposed [3, 4]. Some studies have been reported on transient behaviour for MSFR [5, 6]. Transients are analysed using mainly neutronics and thermal-hydraulics coupled computational fluid dynamics (CFD) code, e.g. COUPLE code [7], HEAT code [8], COMSOL code [9, 10], OpenFOAM code [11–14]. In some cases, system codes like TRACE [15] is used. Recently, the PROTEUS-NODAL code which is a 3D nodal transport code has been developed at Argonne National Laboratory and benchmarked with Trace and CFD [16].

As described above, MSR has several unique features, where liquid fuel salt is circulating in-core and ex-core and there are no cladding tubes of fuel rods. To perform safety analyses for accidents and transients, the selection of models is crucial. Models of these codes vary from one that uses coupling of a three-dimensional (3-D) nuclear reactor model and detailed thermal/hydraulic (T/H) CFD model to a simple point reactor model coupled with lumped parameter model of T/H system.

The validity of fine structures of the transients is quite important for conventional reactor systems using solid fuel rods. Because in these reactors, 3-D evaluation for time-dependent local heat flux and cladding temperature of fuel rods is required to confirm that these parameters are within safety limits of fuel integrity during accidents or transients.

Meanwhile, in safety analyses for MSR, there are no requirements for peak heat flux or fuel cladding peak temperature, because there are no cladding tubes in MSR. For the safety evaluation of MSR, the most decisive parameter is the fuel salt temperature in the fuel salt boundary. As is explained in Section-2, the highest temperature is expected at the outlet of the MSR core under accidents with fuel salt flow. That is, 3-D power distribution is not required. Also, this suggests that a point kinetics model can be applied to the codes.

Based on the above prospects for both nuclear and T/H models, a simple safety and transient analysis code for MSR (**D**Ynamics for **M**Olten **S**alt reactors: DYMOs) has been developed by the authors, and DYMOs code is verified for MSRE experiments as described later.

However, these verifications are for a small experimental MSR, and verification for large reactors is missing. This paper provides the information that the DYMOs code can be applied to these large reactors. The main objective of this article is not to claim the originality of the model of DYMOs code, but to propose applicability of such simple code to large reactor systems. Then, this code can be applied in the actual licensing

**Comment [VL2]:** Explain about MSR.

process by both reactor designers and licensing bodies.

## 2. Features of safety analysis of molten salt reactor system

As discussed above, there is no requirement for local heat flux or temperature in transients of MSR with fuel salt flow. The most important information is the highest fuel salt temperature in the fuel boundary, which is expected as the outlet fuel temperature. Based on heat balance in an MSR core, the outlet temperature is simply obtained as follows.

$$T_{out} = T_{in} + \frac{P}{CG} \quad (1)$$

where

$T_{out}$ : Outlet temperature

$T_{in}$ : Inlet temperature

$P$ : Reactor power =  $\int_{\text{whole core}} p(r, z) dr dz$

$p(r, z)$ : Power distribution in the reactor

$C$ : Specific heat of fuel salt

$G$ : Mass flow rate

The highest fuel temperature is obtained through the integration of reactor power in the whole reactor region, which is the total power generated in the reactor core. This fact means that detailed power distribution is not required when molten salt flow is maintained. The highest fuel temperature is the most decisive parameter for the integrity of the fuel salt boundary. From this point of view, it is expected that the highest fuel salt temperature could be estimated using a simple system model of a point reactor model coupled with heat transfer systems of lumped parameter models.

Based on these prospects, DYMO code has been developed by the authors, and its accuracy is verified for MSRE experiments as shown in Section 3.4. But these verifications are for small experimental MSR, and verification for large reactors is needed. Recently, safety analyses using 3-D power distribution and detailed T/H models for a large reactor system are reported [17]. A comparison between the results of this detailed model and DYMO results for the large reactor system is provided in Section 5.

## 3. Description of DYMO code

### 3.1 Plant model in DYMO code

A simplified plant model in the DYMO code is shown in Figure 1. The concept of Molten Salt Reactors is quite different from those of conventional concept, which use solid type nuclear fuels. MSR under consideration in this article uses high temperature molten fluorides or chlorides salts as nuclear fuel and secondary cooling system. Fuel salt contains fissionable materials. In the reactor fuel salt becomes critical and make

**Comment [VL3]:** 1. What is the advantage of this concept?  
2. Indicate the operating conditions used and what parameters were used in this research?  
2. Describe the dimensional of reactor.

fissions to generate energy. Generated nuclear heat in the reactor core is transferred to a (primary) heat exchanger by a fuel salt loop, and its heat is transferred to, for an example, a steam generator (SG) by a coolant salt loop, and finally used at a turbine/generator, if this plant applies a steam turbine system.

As the fuel salt is circulating the primary loop, part of delayed neutron precursors flow out of the reactor and part of them will return to the reactor. This feature distinguishes the nuclear kinetics of MSR (See section 3.2). However, after the heat is transferred to the secondary system and thereafter, the system can be understood as ordinary heat transferring systems.

From these basic consideration, DYMO code focuses on the fuel salt loop in Figure 1

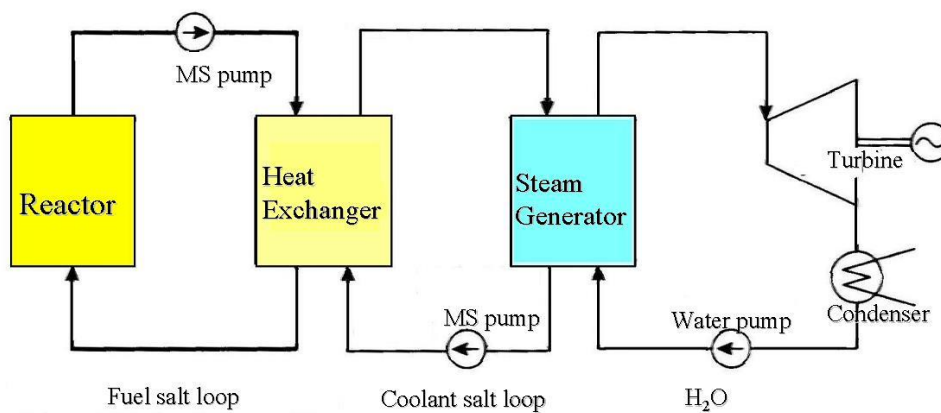

Figure 1 DYMO model for MSR power plants [18, 19, 20]

### 3.2 Reactor kinetics

DYMO code adopts one-point kinetic equations for the reactor power as shown below, which is almost identical to the model used in LWR licensing. The following equations are common in textbooks of reactor physics [18]. The unique difference in MSR is that it considers the circulation of delayed neutron precursors of fuel salt, as is shown in the third and fourth terms of the second equation proposed by ORNL [19].

$$\frac{dn(t)}{dt} = \frac{\rho - \beta_{eff}}{\Lambda} n(t) + \sum_{i=1}^6 \lambda_i C_i(t) \quad (2)$$

$$\frac{dC_i(t)}{dt} = \frac{\beta_{s,i}}{\Lambda} n(t) - \lambda_i C_i(t) - \frac{1}{\tau_c} C_i(t) + \frac{1}{\tau_c} C_i(t - \tau_L) \exp(-\lambda_i \tau_L) \quad (3)$$

$$\rho = (t_f - t_{fd}) * \alpha_f + \rho_{ex} \quad (4)$$

**Comment [VL4]:** How to get this kinetics equation?  
Explain what the reason getting this kinetics value?

$$\beta_{eff} = \sum_{i=1}^6 \beta_i = \sum_{i=1}^6 (\beta_{s,i} - \beta_{loss,i}) \quad (5)$$

$$\sum_{i=1}^6 \beta_{loss,i} = \sum_{i=1}^6 \beta_{s,i} \left[ 1 - \frac{\lambda_i}{\lambda_i + \frac{1}{\tau_c} \{1 - \exp(-\lambda_i \tau_L)\}} \right] \quad (6)$$

$n(t)$  : Number of neutrons

$C_i(t)$  : Number of delayed neutron precursor of i-th group

$\lambda_i$  : Decay constant of i-th group delayed neutron precursor

$\beta_{eff}$  : Effective delayed neutron fraction

$\beta_{s,i}$  : Delayed neutron fraction for static reactor of i-th group

$\beta_{loss}$  : Loss fraction of delayed neutron by fuel salt flow

$\Lambda$  : Neutron generation time

$\tau_c$  : Fuel transit time in the reactor core

$\tau_L$  : Fuel transit time in the loop

$\rho$  : Reactivity

$t_f, t_{fd}$ ; Fuel temperature and design value

$\alpha_f$ ; Fuel temperature reactivity coefficient

$\rho_{ex}$ ; External reactivity

### 3.3 Heat transfer model

Energy generated by fission is transferred to a primary heat exchanger through a fuel salt loop and then transferred to an SG or a secondary heat exchanger and finally to a power conversion system. The respective temperatures can be calculated based on energy flow. The present model is a quite simple one expressed with each system as one point. Although the current DYMOs code can calculate SG, SG is simply treated as the final heat sink in this study to compare the reference design. DYMOs code assumes only one loop, however, it can treat partial loss of fuel salt flow by adjusting the effective flow rate in the reactor core.

Related equations are expressed as follows. The equations are taken after or further simplified from the models presented in the references as follows [20, 21].

In the following equations, there are no parameters and heat transfer for graphite moderators used in thermal reactors. However, the DYMOs model for thermal reactors with graphite moderators is verified as described in Section 3.4.

$$M_f C_{pf} \frac{dT_{out}(t)}{dt} = F_l C_{pf} (T_{in}(t - \tau_L) - T_{out}(t)) + P_r(t) \quad (7)$$

$$M_f C_{pf} \frac{dT_{in}(t)}{dt} = F_l C_{pf} (T_{in}(t) - T_{hx}(t)) - A_{hx} H_{hx} (T_{in}(t) - T_{hx}(t)) \quad (8)$$

$$M_f C_{pf} \frac{dT_{in}(t)}{dt} = F_l C_{pf} (T_{hx}(t) - T_{in}(t)) - Q_{sink}(t) \quad (9)$$

**Comment [VL5]:** How this experience was conducted has not been explained in detail.

$T_{out}, T_{in}, T_{hx}$  : Fuel outlet, inlet and heat exchanger temperature, respectively

$M_f$  : Fuel mass

$C_f$  : Specific heat of fuel

$F_l$  : Fuel flow mass rate

$P_r$  : Thermal power output=fission power + decay heat

$Q_{sink}$  : Heat sink in the primary heat exchanger

Note: The term,  $C(t - \tau_L)$ , in Equation (3) is included to consider of the piping effect due to the circulation of molten salt in the system. Several models were used to represent salt transport in the piping. In this study, the simplest model of a first order time lag of  $\tau_L$  is used as in explained in Ref. [20]. This model is also applied to the returning salt temperature,  $T_{in}(t - \tau_L)$ , presented in Eq. (8) above.

The above differential equations (2) to (9) are solved by numerical integration and its time interval of 0.01 seconds is confirmed to be short enough.

Also, these simple nuclear models and heat transfer models would provide transparency, which means that models can be easily understandable by experts and reproduced in licensing evaluation.

### 3.4 Verification for MSRE experiments

Verification of the DYMO code against experimental data of MSRE, which was operated at Oak Ridge National Laboratory (ORNL) in the 1960s adopting fluoride fuel salt with graphite moderator, is already reported by the authors [22, 23, 24]. In a summary, DYMO code shows good agreement with MSRE results, for the MSRE startup experiment and coast-down experiment at zero-power, and also reactivity insertion experiments at 5MW and 8MW operations.

There is a benchmark report for MSRE zero-power experiments, where various models are compared with MSRE data [25]. DYMO results are also within the variation of various models. As for experiments at power operations, there is another paper using a 3-D detailed multi-physics model [26]. DYMO shows similar results. The above observation would support that a simple one-point model can be applied to MSR safety analysis.

However, MSRE is a small experimental reactor with a power output of around 10MWt. Thus, it is desirable to verify DYMO code for a large power plant. Transient analyses by 3-D T/H detailed codes for such plants are available in the reference[17] shown in the next section. The authors provide a comparison of both results in the following sections.

**Comment [VL6]:** Explain the most important result in this report as state of the art and compare with your research

#### 4. Comparison of the results and discussions

Results of accident analyses and the analytical mode is presented in Ref. [17]. For the convenience of readers, main body of the reference is re-cited in the Appendix.

In Ref. [17], it is claimed that there are four typical transients to show safety characteristics of MSR, which are Loss Of Fuel Flow (LOFF), Loss Of Heat Sink (LOHS), Total BlackOut (TBO), and Reactivity Initiated Accident (RIA). The reason of selecting these transients is briefly discussed in Section 6 of the present paper.

As is explained in Section 2, the outlet temperature of fuel salt is increased when power is increased or flow is decreased. Therefore, it is enough to study RIA as a representative power increase accident and LOFF, LOHS and TBO as representative of flow decrease accidents.

As for RIA analysis, one of the authors has experience with MSR power plant FUJI [27], and as for LOFF at a larger plant MSBR, there is another paper [28]. Based on these studies, a similar approach is applied in the present study.

The numerical results of the reference simulation code are obtained by a digitizer from the figures in the reference [17], which are indicated by character "R". The accident transients by DYMOSS are calculated using the same conditions as those of reference [17].

Additional explanation is given briefly as follows. The flow rate of the fuel salt for DYMOSS calculation is obtained from the data in reference [17]. Also, the transient of heat sink is approximated to follow the power reduction given in reference [17]. Note that these parameters are design dependent and could be known in advance.

The transients for LOFF (100% loss of flow) are compared in Figure 2. In Figure 3, the transient for the loss of flow of 25% is shown. Figures 4 to 6 show comparison of LOHS, TBO and RIA, respectively. Note that the comparisons TBO are made for a short time intervals after the initiation of accidents in which the nuclear power has died out. These accidents could be caused by loss of electricity or troubles in electrical circuits.

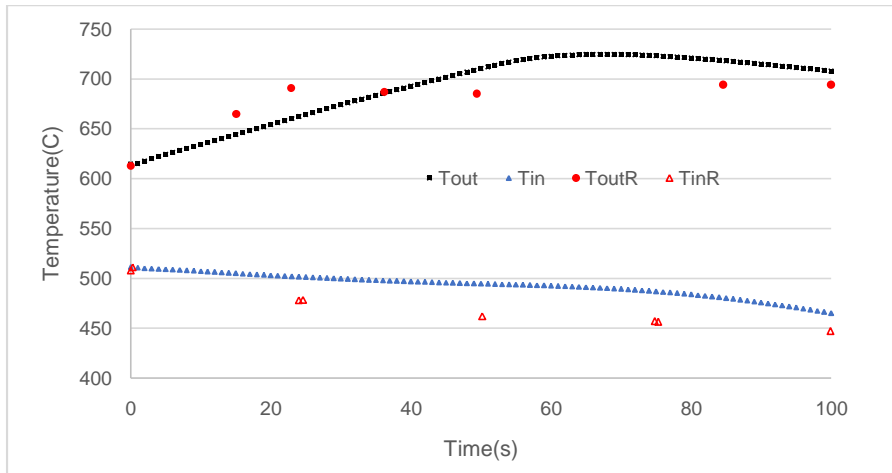

(a) Fuel salt temperature

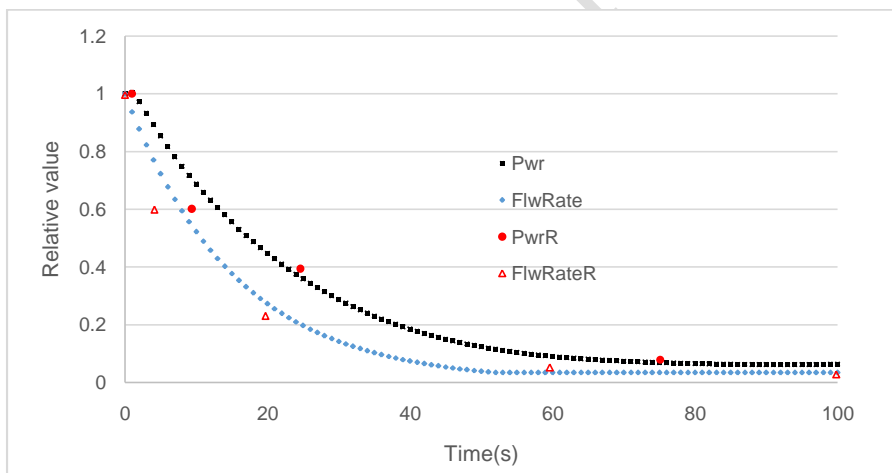

(b) Relative power and fuel flow-rate

Figure 2. Comparison of system transient of Loss of Fuel Flow

(a) Fuel salt temperatures (b) Relative power and flow-rate

**Comment [VL7]:** Need revised  
The legend must be clear and not  
short. Ex: Pwr → Power, etc

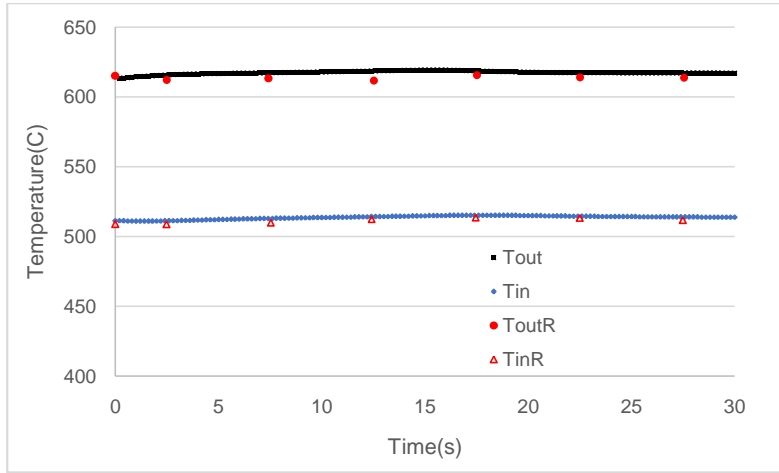

(a) Fuel salt temperatures

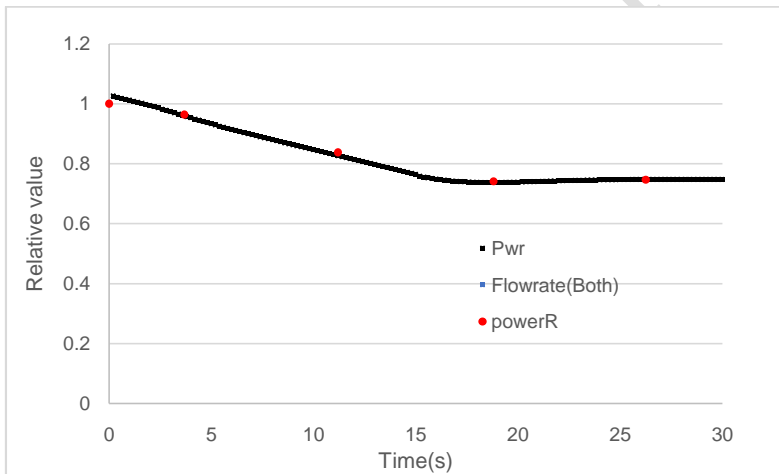

(b) Relative power and fuel flow-rate

Figure 3. Comparison of transient of Loss of 25% Fuel Flow  
 (a) Fuel salt temperatures (b) Relative power and flowrate

**Comment [VL8]:** Please select a different type of curve for joining your experimental data. Make it clear

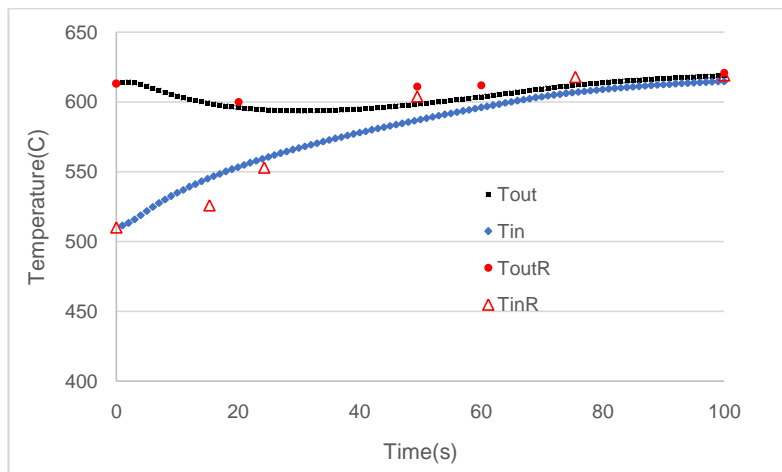

(a) Fuel salt temperatures

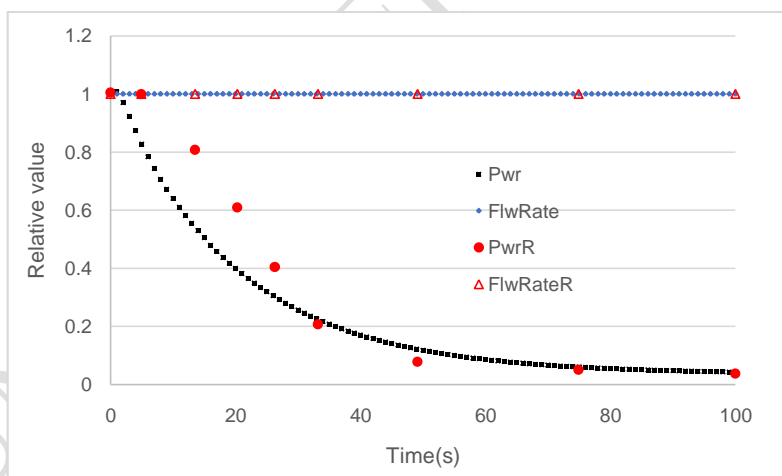

(b) Relative power and flowrate

Figure 4. Comparison of transient of Loss of Heat Sink  
 (a) Fuel salt temperatures (b) Relative power and flowrate

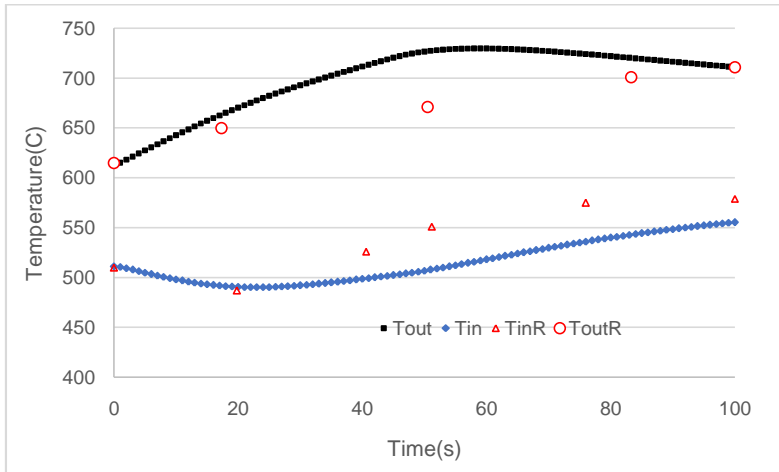

(a) Fuel salt temperatures

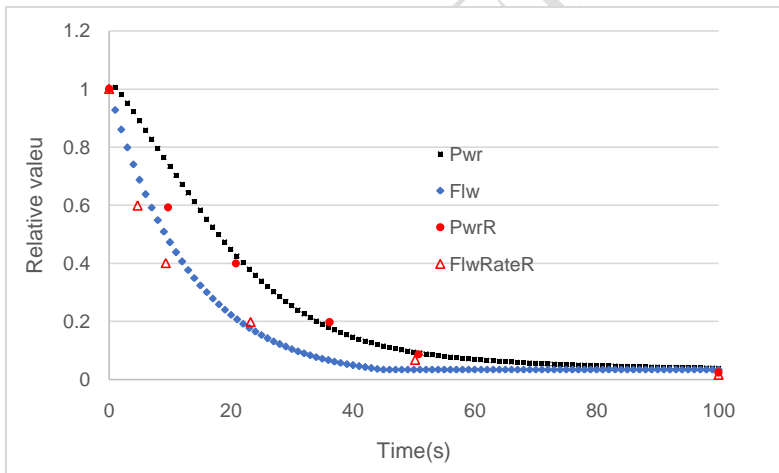

(b) Relative power and flowrate

Figure 5. Comparison of transient of Total Blackout  
 (a) Fuel salt temperatures (b) Relative power and flowrate

On the other hand, RIA in MSRs could be caused by malfunctions of fuel composition adjustment system or control rod drive system in the plants if the plant is equipped with control rods. In the RIA transient, when the heat sink is stay constant, the reactor power is finally stabilized at the same level of the heat sink. However, the result in Ref. [17], the reactor power increases and stays at about 30% higher than the nominal power. This might be caused by the fact that the analytical model in Ref. [17] consists of other heat transfer systems. Thus, it might have large thermal inertia and can absorb more heat than the nominal power. Based on this consideration, RIA transient is analysed by increasing the heatsink about 30% of the nominal value.

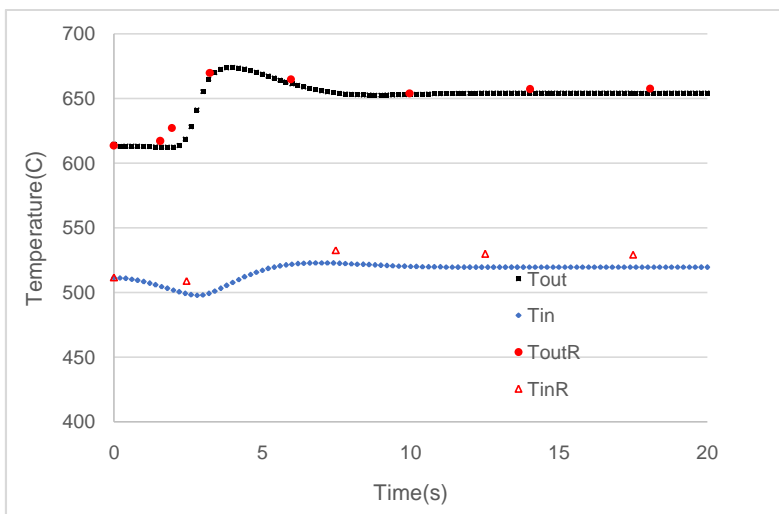

(a) Relative power and fuel flow-rate

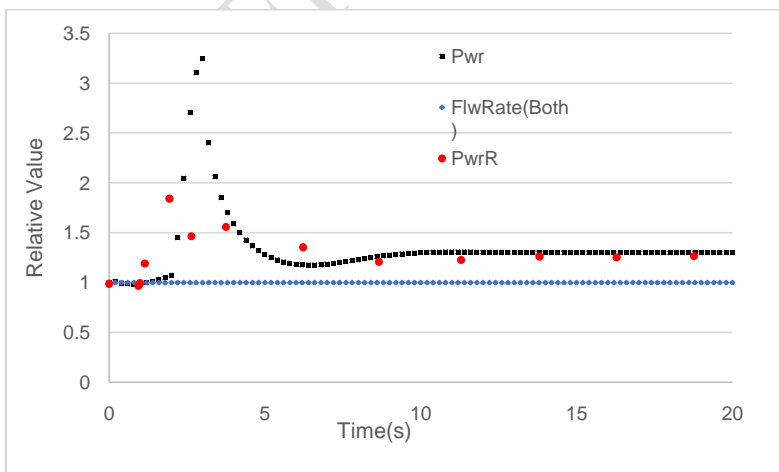

(b) Relative power and flow-rate

**Comment [VL9]:** All your figure need revision

Figure 6. Comparison of transient of Reactivity Initiated Accident (Reactivity of 0.00218 is added in one second and maintained)

(a) Fuel temperatures (b) Relative power and flow-rate

As can be seen, they all show good agreement with small discrepancies from those obtained by the detailed models. However, the authors would like to show that DYMOSS can evaluate the highest fuel temperature within smaller discrepancy form that of detailed analysis codes. The authors understand that the discrepancy still exists but would continue to improve the accuracy when comparable data are available.

**Comment [VL10]:** From sub 3.2, explain the correlation with experimental result.

### 6. Possible accidents in MSR

In order to apply DYMOSS code to transient or accident analysis, it is necessary to investigate possible accidents in MSRs at first. Based on previous authors study [29] [30], possible accidents in MSRs are categorized as shown in Table1. In this table, accidents by external causes such as earthquake or tsunami are not included, because they are studied by other codes. That is, only internal cause accidents are considered. Regarding accidental causes such as overpressure or overheating, they are caused by power increase accident (Type-1) or flow decrease accident (Type-2), because temperature rise or enthalpy rise is proportional to power and inversely proportional to flow. Besides these two accidents, fuel salt leak accident (Type-3) may be caused by other mechanical failures of the primary loop boundary. Therefore, the above three types of accidents must be considered. Of course, some of the second and the third types of accidents may cause a reactivity increase as a result. Meanwhile, the first accident type is usually called a reactivity initiated accident (RIA), because it is initiated by the insertion of positive reactivity at first.

Besides these three categories, the fourth category, named "other accidents" (Type-4) is considered. These accidents are mostly specific to the MSR.

Based on this table, DYMOSS code can evaluate accidents mostly for Type-1 and Type-2. That is, Type-3 and 4 should be evaluated by other codes. From this point of view, studied cases in Section-5 are selected representing Type-1 and Type-2.

Table 1 Accident category

Type	Possible accidents in MSRs
------	----------------------------

1 Power increase accident or RIA (Reactivity initiated accident)

Control rod withdrawal/ejection accident

Cold-loop startup accident

Secondary salt flow increase accident

Secondary salt temperature decrease accident

Fuel salt flow increase accident

Fuel salt filling accident

Excessive fissile addition or fertile removal accident

De-pressurization accident

Fissile precipitation accident

Graphite loss accident

Fissile penetration to graphite accident

---

2 Flow decrease accident

Pump trip accident

Pump seizure accident

Flow blockage accident

Loss of secondary salt cooling accident

Loss of decay heat cooling accident (in core)

Loss of decay heat cooling accident (in drain tank)

---

3 Fuel salt leak accident

Primary loop break accident

---

4 Other accidents

Steam-generator break accident

Recriticality accident in drain tank

Fuel salt freeze accident

Secondary salt freeze accident

Remelt accident

Freeze valve failure accident

Graphite fire accident

Wigner effect accident

Off-gas system failure accident

Reactor oscillation accident

Fuel salt or beryllium release accident

Rupture of containment accident

---

## 7. Conclusion

As explained above, DYMOS code already shows good agreement for MSRE experimental results. The present study shows that DYMOS code also shows good agreement with the results of detailed T/H 3-D codes for large-size plant. As shown and discussed above, the most important parameter in MSR safety design and licensing is the highest fuel salt temperature, and DYMOS code shows good agreement with that obtained by the referenced detailed model. However, it could be pointed out that some discrepancies are seen. As the detailed information of heatsink is not known, it was approximated based on engineering judgement in this analysis. The authors believe that when the heatsink is correctly given or evaluated in the other means of non-nuclear heat transfer analysis, the DYMOS can evaluate the MSR transients with higher accuracy.

Thus, safety analyses for MSR could use a simple point model. Because they require no local heat flux or cladding temperature of the fuel rod but the highest fuel temperature in the primary system.

The great advantage of such simple models is to provide transparency in safety evaluation in licensing procedures, besides reduction of computer burden. For example, the computing time required for each of the transients is in seconds on the personal computers at hand. Thus, it can be used to perform various parameter studies in a short time.

## References

- [1] Serp, J., et al., The Molten Salt Reactor (MSR) in Generation IV: Overview and Perspectives. *Prog. Nucl. Energy.* 77, p.308-319, (2014).
- [2] Dolan, T.J. (editor), Molten Salt Reactors and Thorium Energy, Woodhead Publishing (Elsevier), (2017 & 2023).
- [3] Krepel, J., Dynamics of Molten Salt Reactors, Thesis for Ph.D. at PSI, Oct, (2006).
- [4] Wooten, D, Powers, J. J., A Review of Molten Salt Reactor Kinetics Models, *Nucl. Sci. Eng.*, Volume 191, p203-230, (2018).
- [5] Brovchenko M, Heuer D, Merle-Lucotte E, et al. Design-related studies for the preliminary safety assessment of the molten salt fast reactor. *Nucl Sci Eng.* 2013;175(3):329–339.
- [6] Brovchenko M, Merle-Lucotte E, Heuer D, et al., 2013. Molten salt fast reactor transient analyses with the COUPLE code, Proc. of the ANS Annual Meeting, Atlanta, USA. <https://www.researchgate.net/publication/275019982>
- [7] Zhang D, Zhai Z-G, Rineiski A, et al., 2014. COUPLE, a time-dependent coupled neutronics and thermal- hydraulics code, and its application to MSFR, Proc. of the 2014 22nd International Conference on Nuclear Engineering (ICONE22), Prague, Czech, ICONE22– 30609. DOI:10.1115/ICONE22-30609

- [8] Fiolina C, 2013. The molten salt fast reactor as a fast- spectrum candidate for thorium implementation, PhD Thesis, Politecnico di Milano.
- [9] Comsol Multiphysics®, 2018. COMSOL Multiphysics programming reference manual. [https://doc.comsol.com/5.4/doc/com.comsol.help.comsol/COMSOL\\_ProgrammingReferenceManual.pdf](https://doc.comsol.com/5.4/doc/com.comsol.help.comsol/COMSOL_ProgrammingReferenceManual.pdf)
- [10] Laureau A, Heuer D, Merle-Lucotte E, et al. Transient coupled calculations of the molten salt reactor using the transient fission matrix approach. Nucl Eng Des. 2017;316:112–124.
- [11] Gérardin D, 2019. Développement de méthodes et d'outils numériques pour l'étude de la sûreté du réacteur à sels fondus MSFR, PhD Thesis, Grenoble Institute of Technology. <https://tel.archives-ouvertes.fr/tel-01971983/document>
- [12] Wan C, Hu T, Cao L. Multi-physics numerical analysis of the fuel-addition transients in the liquid-fuel molten salt reactor. Ann Nucl Energy. 2020;144:107514.
- [13] Gonzalez Gonzaga de Oliveira R, 2021. Improved methodology for analysis and design of molten salt reactors, PhD thesis, École Polytechnique fédérale de Lausanne, Thèse No 8618.
- [14] OpenFOAM®, 2019. OpenCFD Release OpenFOAM® 1912. <https://www.openfoam.com/news/main-news/openfoam-v1912>
- [15] Pettersen EE, 2016. Coupled multi-physics simulations of the molten salt fast reactor using coarse- mesh thermal-hydraulics and spatial neutronics, Master Thesis, Paris-Saclay University. <https://www.psi.ch/sites/default/files/import/fast/PublicationsEN/FB-DOC-16-016.pdf>
- [16] Jaradat MK, Park H, Yang WS, et al. Development and validation of PROTEUS-NODAL transient analyses capabilities for molten salt reactors. Ann Nucl Energy. 2021;160:108402.
- [17] Mochizuki, H., Neutronics and Thermal-hydraulics Coupling Analyses on Transient and Accident Behaviors of Molten Chloride Salt Fast Reactor, Journal of Nuclear Science and Technology, (2018). <https://doi.org/10.1080/00223131.2022.2131647>
- [18] Duderstadt, J. J., Hamilton, L. J., Nuclear Reactor Analysis, Jhon Wiley & Sons, Inc. (1976)
- [19] Sides, W. H., MSBR Control Studies. ORNL-TM-3102, 1971.
- [20] T.W. KERLIN, S. J. BALL, R. C. STEFFY, R. C. STEFFY, THEORETICAL DYNAMICS ANALYSIS OF THE MOLTEN-SALT REACTOR EXPERIMENT, NUCLEAR TECHNOLOGY VOL. 10 FEBRUARY 1971 118-132
- [21] M. Zarei, A refined time-delay modeling of the molten salt reactor dynamics, Energies 2021, 14, 5279. <https://doi.org/10.3390/en14175279> <https://www>

- [22] Shimazu, Y., Yoshioka, Y., Ogasawara, K., Furukawa, M., Transient Analysis Code for Molten Salt Reactor: DYMOSS, AESJ 2021 September Conference (in Japanese), (2021).
- [23] Yoshioka, R., Kinoshita, M., Safety of MSR-FUJI, Technical Meeting on the Safety of High-Temperature Gas Cooled Reactors and Molten Salt Reactors, May 9-13, 2022, IAEA, (2022).
- [24] Yoshioka, R., Kinoshita, M., Transient and safety analysis code DYMOSS, Section 11.8 of the book "Molten Salt Reactor and Thorium Energy", Elsevier, USA, (2023).
- [25] Delpech, M., et al., Benchmark of Dynamic Simulation Tools for Molten Salt Reactors, Proceedings of GLOBAL-2003, New Orleans, USA.
- [26] Zanetti, M., et al., A Geometric Multiscale Modelling Approach to the Analysis of MSR Plant Dynamics, Progress in Nuclear Energy vol.83, p.82-98, (2015).
- [27] Suzuki, N., Shimazu, Y., Reactivity-initiated-accident analysis without scram of a molten salt reactor. Nuclear Science and Technology, vol.45, No.6, p.575-581, (2008).
- [28] Shimazu, Y., Locked Rotor Accident Analysis in a Molten Salt Breeder Reactor, Nuclear Science and Technology, vol.15, No.12, p.935-940, (1978).
- [29] Yoshioka, R., Mitachi, K., Shimazu, Y., Kinoshita, M., 2014. Safety criteria and guidelines for MSR accident analysis. In: PHYSOR-2014, Kyoto, Japan.
- [30] Yoshioka, R., Kinoshita, M., MSR accident analysis, Section 11.5 of the book "Molten Salt Reactor and Thorium Energy", Elsevier, USA, (2017).
- [31] ANS-5.1, Decay energy release rates following shutdown of uranium-fuelled thermal reactors, Draft ANS-5.1/N18.6., (1973).

## **Appendix: Reference accident analysis model [5]**

### **A.1 Detailed analysis model in reference**

In the reference analytical model, two well-known codes, namely RELAP5-3D and FLUENT, are coupled in such a way that the fuel salt behavior in the core is calculated by the FLUENT code with inlet boundary conditions calculated by the RELAP5-3D, and the reactor power computed by FLUENT is transferred to RELAP5-3D to calculate the plant system. Both codes are modified or implemented of the function to calculate the delayed neutron behavior and the obtained results are validated against the experimental data of MSRE at ORNL. A detailed description is available in reference [5]. The behavior of neutrons in the core is based on one-point kinetics. The kinetic parameters under the steady state conditions are analyzed using the values shown in Table 1 [5]. The reactor power distribution is assumed to be a function of cosine in the axial direction and a Bessel function in the radial direction of a cylindrical core model. The decay heat is calculated using a well-known equation proposed by the American Nuclear Society [31] for light water reactors.

### **A.2 Target system**

A schematic diagram of the conceptual Molten Chloride Salt Fast Reactor in the present study is illustrated in Figure 7[17]. This study assumes a four-loop system. Table 2 shows the dimensions of the primary Heat Transport System (HTS). The reactor core is a simple cylinder with conical components at the top and bottom. Hot legs are provided at the top of the reactor core. The primary HTS consists of the reactor core, gas treatment equipment (Not shown in Figure 7), a fuel salt pump, and a fuel salt to coolant salt heat exchanger (FCHX). The secondary HTS consists of an FCHX of the secondary side, a coolant salt pump, heat storage tanks, a gas heat exchanger (HX), and a decay heat removal system (DHRS) with an air cooler (AC). The heat storage tanks are omitted in reference [17] because the volume is undetermined and the tanks are required for load-following operations except for daily load-following. Thus, this system is also also omitted in DYMOSE.

The discretized equations are coded using the C-language in the user-defined function (UDF) and incorporated into FLUENT by compiling the UDF. The changes in the core transit time and the exterior loop transit time are calculated using the flow rate in the combined UDF, and the kinetic parameters are updated in every time step. The temperatures of mesh elements in the core calculated by FLUENT are collected to calculate the average temperature of the core. The reactivity is calculated based on the change in the average fuel salt temperature, which is reflected in the reactor power.

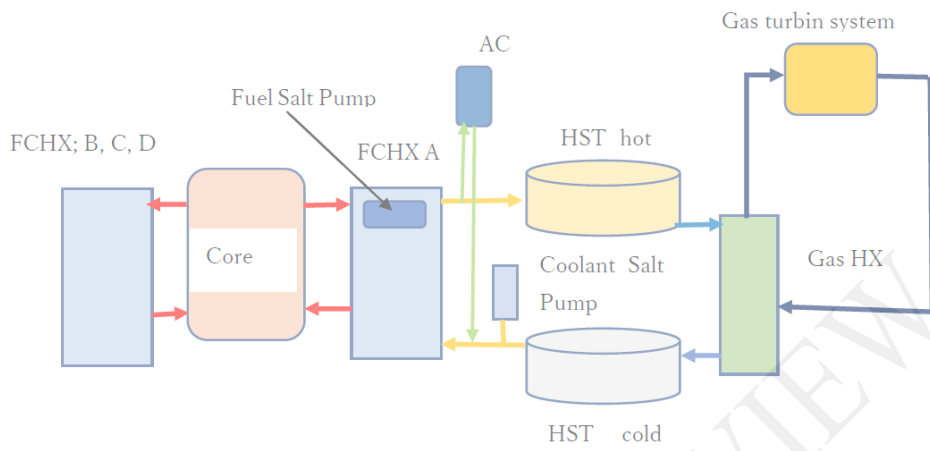

Figure 7. Schematic of a referenced conceptual molten chloride fast reactor [5]; Reproduced by the authors

Table 2(A) Kinetic parameters [5]

Group	$\beta_i(\text{Static})$	$\lambda_i(\text{s}^{-1})$
1	0.00009	0.01338
2	0.00062	0.03068
3	0.00056	0.11671
4	0.00135	0.30604
5	0.00078	0.87593
6	0.00026	2.94183

Prompt neutron lifetime:  $5.65 \times 10^{-7} (\text{s}^{-1})$

Table 2(B) Dimensions of the primary heat transfer system [5]

Component	Dimension	Remarks
Core diameter	2.3 m	
Core height	2.4 m	Cones with 0.1 m
Fuel transit time in the reactor core, $\tau_c$	2.46 s	At full flow
Fuel transit time in the loop, $\tau_L$	2.69 s	At full flow
Hot-leg inside diameter (ID)	0.4 m	4 Loops, 4.6 m in length
FCHX channel (width/height)	10 mm/7 mm	Number of channels 7200 Length: 3 m
Cold-leg ID	0.4 m	2.4 m in length
Total volume	$9.7 \text{ m}^3$	
Mass flow rate	3075 kg/s/loop	