

Interchange and Compact Grade Separated Junction: classifications system considerations, traffic safety, and operations overview.

ABSTRACT

The paper presents system considerations and classification criteria of interchange geometric design based on the new Israeli Interchange design guidelines (VOLUME III of geometric design standards for rural (interurban) highways and urban freeways).

The paper gives a methodological overview of interchanges systematical warrant in order to adjust and essentially construct an appropriate interchange that connects two intersecting highways. This warrant refers to the number of legs, partiality, functional classification, and access control type of intersecting highways zone (in the final stage of construction) based on highway classification. The paper also covers system considerations for implementing a compact grade separated junction (CGSJ) in a major highway, and traffic operation, safety, and public transport insights.

Keywords: *interchange, classification, safety, highway, system*

INTRODUCTION

An interchange is a system of interconnecting highways in combination with one or more grade separations that provides the movements of traffic flow between two or more highways on different levels. Crossing conflicts are eliminated by grade separations and turning conflicts are minimized depending on interchange functional classification and configuration. The driver is required to select a suitable speed, accelerate and decelerate, and choose appropriate lanes in order to make merging and diverging maneuvers. Another definition of interchange refers to "a material object whose form is determined by the physics of motorized movement and economics of construction, as well as the semiotic coding of driving into a binary chain of switching operations intended to reduce anxiety and equivocation" (Kozlovsky 2019). A third definition of interchange by U.K. DMRB manual for geometric design of grade separated junctions (CD122, 2022) is "a grade separated junction that provides free flow from one mainline to another". The U.K. DMRB (CD122, 2022) also referred a lower-level interchange: Compact Grade Separated Junction (CGSJ). This transportation facility is a grade separated junction designed with a two-way undivided link road between the major road and minor road. The minor road connects the major road by an unsignalized intersection (termed: at grade priority junction).

The basic principles of interchange design assist the driver to pass with minimum disturbance of exiting and entering traffic without difficulty that the through highway is the correct one for the driver's destination. A high-quality design enables the driver to understand the operation of the interchange without being misled or surprised by any design feature. Route continuity, provision of adequate sight distance, and uniformity of signing are important features in this manner.

The major objectives of interchange geometric design procedures are: (1) A framework of a reliable design that enables a comprehensive design process. (2) Distinction between interchange types, based on intersecting highways' classification. (3) Generating systematic concepts and design elements of the interchange components in order to produce the entire interchange scheme based on the implemented design criteria. (4) Determination of access control type related to intersecting highways' zone.

This paper presents principles of classifications, systems' considerations, and traffic operation and safety aspects, which are beneficial for interchange and compact grade separated junction (CGSJ) geometric design compared to signalized intersections. In practice, choosing an appropriate interchange for a site is critical for improving the efficiency of the transportation system.

LITERATURE REVIEW: interchange safety, complexity, guidance signs, and operational performance

Transport interchanges play a key role as urban transport network focal points and enhance public transport operation (Lopez-Lambas, Monzon 2010). Interchange is considered critical among suitable facilities implemented along motorway for the benefits of public transport. Interchanges could therefore be taken into account between long distance and local public transport located at motorway junctions (Bowers 2011). Travelers' physical experiences and psychological acknowledgement are also influenced by the design and operation of interchange (Terzis and Last 2000).

Guidance signs effects on interchange design and driving perceptions

Abreu and Bazrafshan (2013) found that satisfaction levels are significantly influenced by the use of guidance signs. Hernandez et al. (2016) implemented a case study of Moncloa urban transport four-level directional interchange (Madrid Spain) to advise that the information provision of guidance signs and the components of interchange internal design have a direct impact on aspects related to safety performance and security conditions principally during day time .

Hamaoka and Matsubara (2019) emphasized the importance of interchange design and its linkage to possible higher risks of wrong-way driving such as “exit at previous interchange” and “overrun the objective interchange”. They emphasized the significance of fully separated conditions for merging lane (“inflow lane”) and diverging lane (“outflow lane”) and the adequate location of signpost at the “demerging section” (prior to merging influence area).

Li et al. (2018) presented a comprehensive evaluation and classification of interchange diagrammatic guide signs' complexity in order to understand how well drivers can perceive them. The interchange degree of complexity affects the ramification of diagrammatic guide signs. They concluded that in order to improve traffic safety and driver understanding it is better to simplify the highly complex signs by splitting and repeating the settings and arranging auxiliary markings.

Additionally, signing located ahead of the interchange could provide information that prepares drivers to decide on the proper maneuvers in advance (Doctor et al. 2009). Even sign consistency along the interchanged highway corridor which is performed by lane assignment arrows, diagrammatical legend, and letter height could reduce the road user workload.

Complex interchange: traffic safety, signing and interchange classification relevance

Sadia and Polus (2013) presented an interchange complexity model (ICM) based on driving workload in interchanges in order to evaluate crash potential. The more complex the interchange is, the driver depends upon more workload resources. The ICM results revealed that complex interchanges which received high ICI (Interchange Complexity Index) ratings have more traffic crashes. The reasons are high workload demand of drivers and increased risks of driving faults. Interchanges that incorporate high Average Annual Daily Traffic (AADT) contribute to high workload and increase risk because interchange design becomes complicated in order to transfer traffic volumes, but is also exposed to more interactions between drivers which corroborates high probability of crash.

Complex interchanges usually do not have conventional layout patterns like diamond and cloverleaf service interchanges. Suitable ramp separation is essential for clear and simple guide signing. Clear signing is required if service interchange and specifically service ramps are close to a system interchange. Such a scheme increases interchange design complexity and drivers need to perceive the correct way of their route (Doctor et al. 2009).

The provision of high-quality public transport interchange facilities at motorway junctions might also increase interchange complexity but could significantly improve the attractiveness of public transport based on motorways routes. Its benefits are environmental (reduced noise, emissions, and land for transport infrastructure) and social (wider access to employment and services). The forms of increasing traffic capacity for passenger cars and trucks like additive lanes will diminish i.e. make motorways simpler but the interchange transport facility design will be more complex due to supplemental elements of public transport. A schematic layout of interchange with public transport and parking elements is introduced in Figure 3 (Bowers 2011).

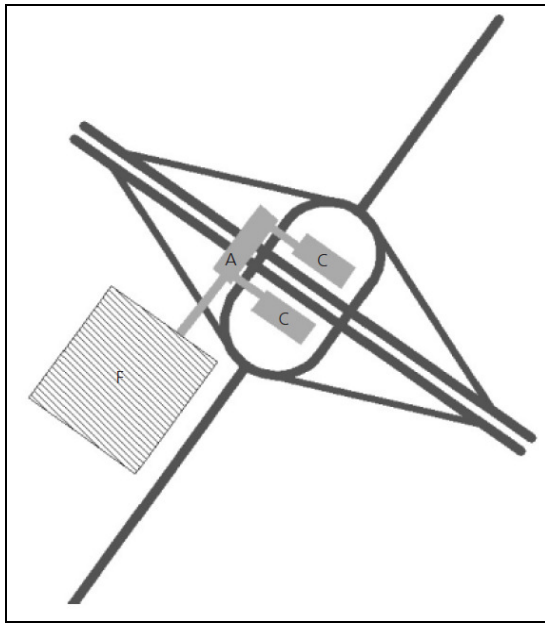

A: Interchange point and passenger facilities on new motorway overbridge; C: Online bus stopping areas and passenger facilities; F: Park and ride facilities.

Figure 1: Schematic layout of motorway public transport interchange (Bowers 2011)

Overall, when designing complex interchanges taking the entire corridor into consideration (and not just the single interchange) can improve traffic safety and operation of the regional transportation system, and minimize contradicted expectations of the drivers.

Single point urban interchange vs. tight diamond interchange

Yue et al. (2019) presented a study which concentrates on operational efficiency evaluation of diamond service interchanges: single point urban interchange (SPUI) vs. **compressed diamond interchange** i.e. tight diamond interchange (TDI). These interchanges are common in U.S. due to their acceptable safety level and operational performance (Jones et al. 2003). Analytical models of capacity and delays and simulation outputs revealed that SPUI with frontage road (SPUI-F) is less efficient than TDI in delay operational performance (Yue et al. 2019). This finding is consistent with Leisch et al. perceptions that TUDI which costs less could accommodate a greater variability in traffic forms and wide range of traffic signal phasing patterns that match vehicle demand (Leisch et al. 1989). These outcomes contradict other research works (Jones and Selinger 2003, Fowler 1993) that SPUI has an advantage in volume to capacity ratio for most volume conditions and therefore provides better traffic operational performance than TUDI (lower delays, and higher capacity performance).

Nonetheless, according to Yue et al. (2019) TDI is superior for transferring heavy vehicles. Queue length advancement is faster in SPUI, and results in earlier severe congestion. These

findings still do not abort the advantage of SPUI special geometry which enables dual left turns and specifically its efficiency of heavy vehicles left turns scenarios. The fewer conflict points of SPUI might imply in supplemental traffic safety advantage. Bared et al. (2003) suggested by traffic simulation models that when left turn maneuvers on exit-ramp (off-ramp) are less than 900 vehicles/hour (vph) the delays and stopping times are not significantly different between SPUI and TDI. However, when off-ramp left turns are greater than 900 vph the estimate delays and stopping times are higher for TDI meaning that in addition to left turn heavy traffic SPUI is superior for high off-ramp left turn flows. Nonetheless, SPUI interchange is inferior for bus-stops integration and pedestrian mobility.

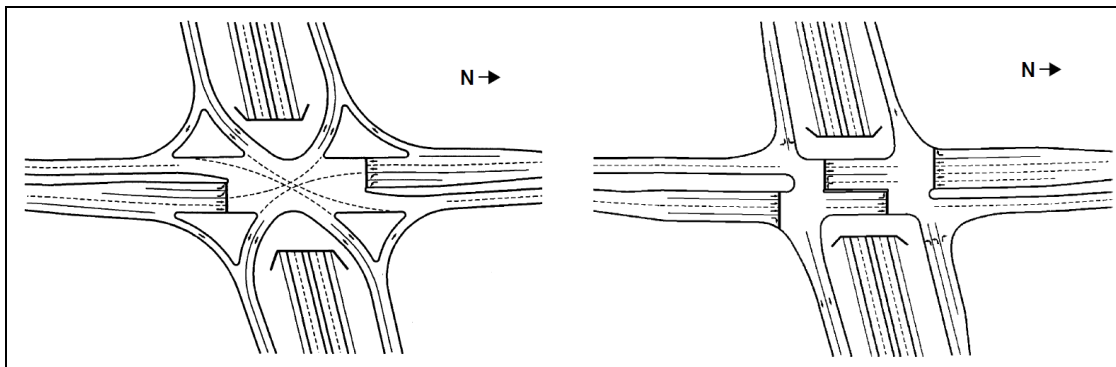

Figure 2: Single point diamond (left) Vs. tight urban diamond interchange (right), [Selinger and Sharp 2000].

Selection of interchange, grade separation, and intersection based on classification of intersecting highways

IRC (2017) recommends on the feasibility of complete interchanges along rural and urban corridors as presented in Table 1. The guidelines do not specify whether the interchange is system interchange or minor (access) interchange, neither propose a different transportation solution rather than interchange. The road category of urban and rural corridor obtains identical recommendation in each cell, such that one table covers both road typology.

Table 1: Guiding principles for assessing the feasibility of complete interchanges along rural and urban corridor (IRC 2017).

Road Typology	Rural: ODR/ MDR	Rural: State Highway	Rural: National Highway.	Rural: Expressway.
	Urban: Collector.	Urban: Sub- Arterial.	Urban: Arterial.	Urban: Expressway.

Rural: ODR/MDR. Urban: Collector.	Highly not recommended	Not Recommended	Generally not recommended	Recommended based on site condition.
Rural: State Highway. Urban: Sub-Arterial.	Not Recommended	Generally not recommended	Recommended based on site condition.	Generally Recommended
Rural: National Highway. Urban: Arterial.	Generally not recommended	Recommended based on site condition.	Generally Recommended	Recommended
Rural: Expressway. Urban: Expressway.	Recommended based on site condition.	Generally Recommended	Recommended	Highly Recommended

ODR: Other District Road; MDR: Major District Road.

The UK DMRB guidelines (CD122 2022) recommends that full grade separated junctions (interchanges) should be used on dual carriageways and motorways. Compact grade separated junctions (CGSJs) shall not be used on: motorways, dual carriageways and single carriageways when mainline traffic flows are above 30000 AADT. CGSJs should be used on single carriageways when the mainline junction has a section of physical central reserve to prevent right turn movements (i.e. preventing left turn movements in US or other European countries and not in UK or Australia).

Table 2 presents a more delegate guide to the selection of interchange, grade separation, and intersection based on roads' classification according to Canadian highway design guidelines (TAC 2017). In Canadian highway design guidelines if interchange is recommended there is no specification, whether the interchange is system interchange or minor (access) interchange. Expressways are urban freeways. Arterials in the interurban system are major highways or regional highways. The rural and urban corridors could include the road categories: local, collector, arterial, and freeway.

Table 2: Selection of interchange, grade separation, and intersection based on roads' classification (based on TAC 2017).

Intersecting Road	Consideration Based on Classification	
	Rural	Urban
Freeway / Freeway	(A) Interchange in all cases.	(A) Interchange in all cases.
Freeway / Expressway	Varies by jurisdiction	(A) Interchange in all cases.
Freeway / Arterial	(B) Normally interchange, but only grade separation where traffic volume is light.	(C) Normally interchange, but only grade separation where interchange spacing is too close.
Freeway / Collector or local	(D) Normally grade separation or alternatively the collector/local may be closed.	(E) Normally grade separation, but an interchange may be justified to: (1) relieve congestion, or (2) serve high density traffic generators.
Expressway/ Expressway	Varies by jurisdiction	(A) Interchange in all cases.
Expressway/ Arterial	Varies by jurisdiction	(F) Normally interchange or intersection (refer to C or G).
Expressway/ Collector or local	Varies by jurisdiction	(G) Normally grade separation, but an intersection may be justified to: (1) relieve congestion, or (2) serve high density traffic generators.
Arterial/ Arterial	(H) Normally intersection, but an interchange may be justified where: (1) capacity limitation causes serious delay, or (2) injury and fatality rates are high, or (3) one arterial may be upgraded to a freeway in the future.	(H) Normally intersection, but an interchange may be justified where: (1) capacity limitation causes serious delay, or (2) injury and fatality rates are high, or (3) one arterial may be upgraded to a freeway in the future.

Intersecting Road	Consideration Based on Classification	
	Rural	Urban
Arterial / Collector or local	(I) Normally intersection or alternatively the collector/local may be closed.	(H) Normally intersection, but an interchange may be justified where: (1) capacity limitation causes serious delay, or (2) injury and fatality rates are high, or (3) one arterial may be upgraded to a freeway in the future. OR (I) Normally intersection or alternatively the collector/local may be closed.
Collector or local / Collector or Local	(J) Normally intersection or alternatively, one road may be closed.	(J) Normally intersection or alternatively, one road may be closed.

AASHTO (2018, 2011) presents several interchange types that are adaptable on freeways and the possible classification of intersecting highways in rural suburban and urban zones (Figure 3). The interchange type clarifies whether the recommended interchange is system interchange (if both intersecting highways are freeways) or minor (access) interchange such as cloverleaf or diamond or integrated between the two (if the minor intersecting highway is arterial or collector or local).

INTERCHANGE CLASSIFICATIONS

There is a variety of interchange types options for the highway engineer. The classification of the intersecting highways is a prime factor in the selection of the most suitable interchange.

The conventional criteria for interchange classification are: (1) Number of legs; (2) Functionality level in the highway system; (3) Partiality level.

Additional factors for selecting the most appropriate interchange are: systems considerations and design consistency, adjacent land use, design speed, traffic volume and traffic composition, traffic control devices, topography, right of way and property requirements, and environmental considerations (TAC ATC 2017). These factors affect the conventional criteria presented as follows.





TYPE OF INTERSECTING FACILITY	RURAL	SUBURBAN	URBAN
LOCAL ROAD OR STREET	 <p style="text-align: center;">- A -</p>		 <p style="text-align: center;">- B -</p>
COLLECTORS AND ARTERIALS	 <p style="text-align: center;">- C -</p>		 <p style="text-align: center;">- D -</p>
FREEWAYS	 <p style="text-align: center;">- E -</p>	 <p style="text-align: center;">- F -</p>	

Figure 3: Adaptability of interchanges on freeways as related to types of intersecting facilities (AASHTO 2018, 2011).

Number of legs

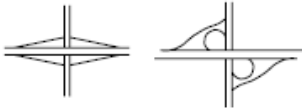
The basic configuration of an interchange is determined by the number of legs intersecting the interchange:

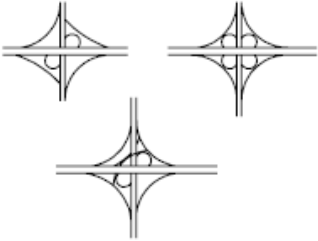
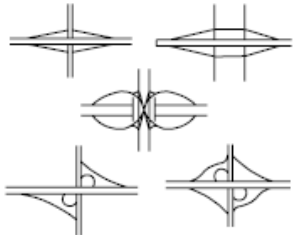
Interchanges with 3 legs: one of the intersecting highways ends in the interchange.

Interchanges with 4 legs: two highways are continuous on both sides of the interchange.

Interchanges with more than 4 legs (not recommended): more than two highways intersect in the interchange. The geometrical solution of this interchange type is unique, generally by integrating a configuration from previous types (3 and 4 legs).

Partiality

An interchange can be partial or full, based on the available traffic movements.

A partial interchange enables some of the traffic movements between the interchange legs, such that pairs of specific movements and reversed ones are applicable.

A full interchange enables traffic movements from every leg to all other legs.

Interchange functional classification

There are two types of interchanges with different functional classification:

Access (or minor or service) interchange: Interchange that connects highways while at least one of the intersecting highways is not fully interchanged. The minor highway has partial access control and therefore includes a certain level of accessibility. It enables non grade-separated connections from the ramps, i.e. ramps with signalized intersections. The ramp edge functions as a leg of an intersection (signalized or unsignalized or roundabout).

System (or major) interchange: Interchange that connects two fully interchanged highways (full access control highways) i.e. highways without intersections. All ramps in a system interchange begin or end with ramp terminals and not with intersections. The ramps of system interchanged are fully directional or semi-directional and therefore designed for a high level of traffic flow and higher design speeds than ramps of a service interchange.

The difference between access and system interchange impacts the selected interchange configuration and ramp types.

Construction considerations

It appears that an intermediate stage of construction would inquire a partial design of the ramps while their edges connect to an intersection and not to a ramp terminal due to budget constraints, right of way, and zone constraints. Such interchange can still function as a system interchange even though some ramps characterize a service interchange.

The major configurations based on the number of legs and functionality are presented in [Table 3](#). Examples are given in [Figure 4](#), and [Figures 5a, 5b](#). Each configuration could have a different version or a mixed version of several configurations (an integrated interchange) based on design considerations, and other constraints that the highway engineer might take

into account. Table 4 presents several single line examples of interchanges' configurations revealed in Table 3.

Table 3: Major configurations of interchanges based on the number of legs and functionality.

Interchange classification	Three leg interchange	Four leg interchange
System interchange	Direct interchange (T, Y(fork)), Trumpet, pear.	Direct interchange (fully or partial), windmill, full cloverleaf (parclo).
Service interchange	T with intersection, half diamond	Diamond, Partial cloverleaf (parclo), two level rotary.

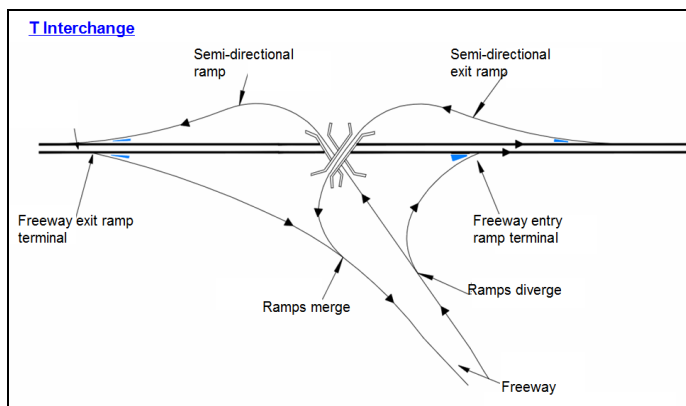

Figure 4 : Examples of 3-leg interchange components (T interchange).

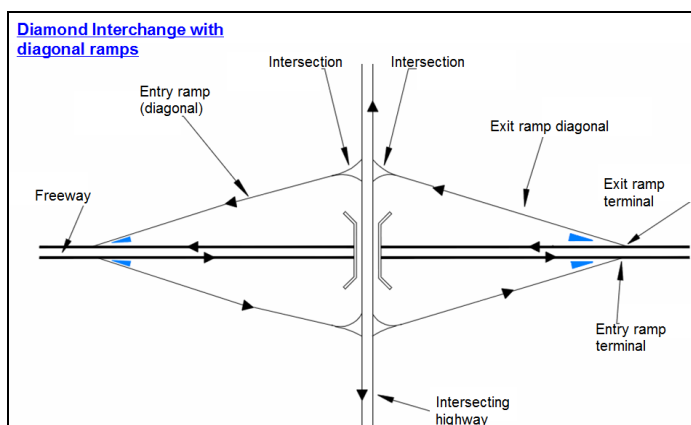

Figure 5a: Example of 4-leg service interchange components (diamond with diagonal ramps).

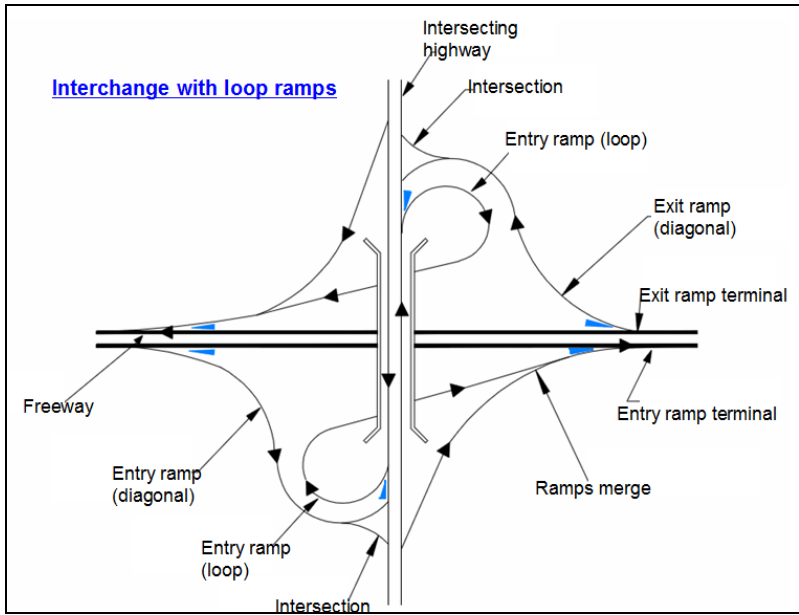
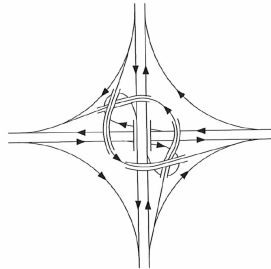
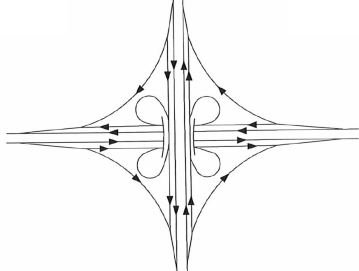
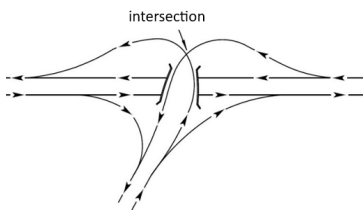
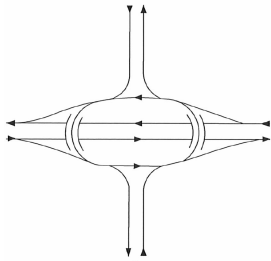
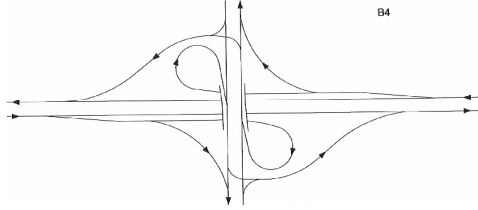

Figure 5b: Example of 4-leg service interchange components with loop ramps.

Table 4: schematic single line configuration examples of system and service interchanges

Interchange	Schematic single line configuration	System interchange /service interchange	3 legs/ 4 legs
Direct- trumpet (A)		System	3
Direct fully		System	4

Interchange	Schematic single line configuration	System interchange /service interchange	3 legs/ 4 legs
Direct partial		System	4
Full cloverleaf		System	4
T with intersections		Service	3
Two level rotary		Service	4
Partial cloverleaf (PARCLO B)		Service	4

A SYSTEMATICAL WARRANT FOR INTERCHANGE CONSTRUCTION: HIGHWAY CLASSIFICATION AND ACCESS CONTROL

The basic criterion which determines the requisite of interchange construction is the classification of intersecting highways including their corresponding level of access control. The decision of implementing full access control, specifically, construction of a freeway or fully interchanged highway signifies a warrant for grade separation or an interchange, between intersecting highways.

Table 5 indicates the access control type of intersecting highways zone based on Israel Interchange design guidelines (Bassan 2022), basically between interurban highways or between an interurban highway and urban arterial. This table represents the final stage of construction. The major considerations for generating Table 5 are mobility and accessibility in the highway network. Its outcome is partially based on Table 2 (TAC 2017) and on Figure 3 (AASHTO 2018, 2011) but refers to highways' classification in Israel (Bassan et al. 2015) and provides more information and flexibility to the highway engineer in selecting the highway control type.

The access control type of intersecting highways zone according to Israeli highway design guidelines are:

- (1) **System (major) interchange (A).**
- (2) **Service (access, minor) interchange (B).**
- (3) **Compact grade-separated junction (C):** a compact interchange with limited zone, and lower design criteria. It is utilized for intersecting full access control (fully interchanged) highway and minor road with low hierarchy. The minor intersecting road usually includes a reduced traffic volume: 10% of the traffic volume traveling on the major intersecting highway.

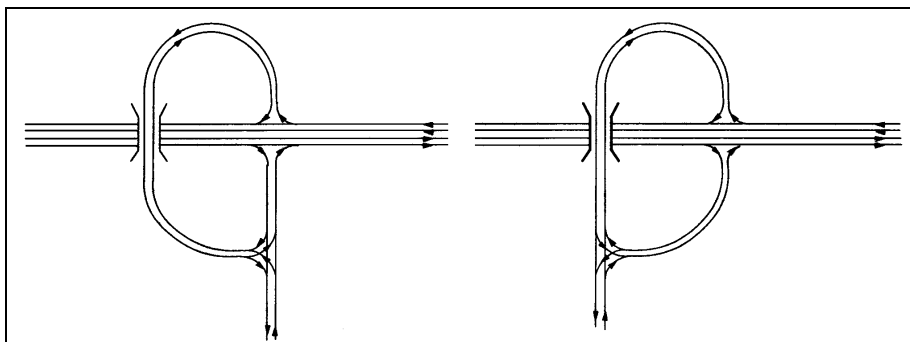

Figure 6: Compact grade separated junction.

(4) Intersection (D)

D1: Signalized intersection.

D2: Unsignalized channelized intersection.

D3: Unsignalized intersection with traffic signs.

D4: Roundabout.

(5) Grade separation (E): Crossing of two highways on separated grades without the option of traffic passing between them. The grade separation creates underpass and overpass without connecting ramps. It maintains safety and mobility.

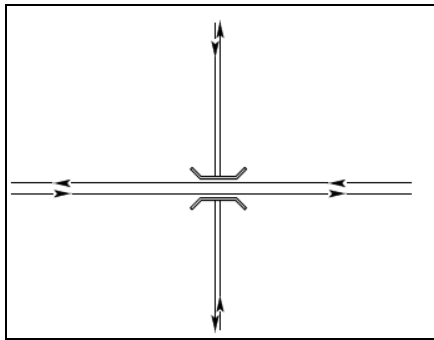

Figure 7: Grade separation.

(6) Connection to service road (F): The minor road is disconnected from the interchanged highway because it has local access purposes only.

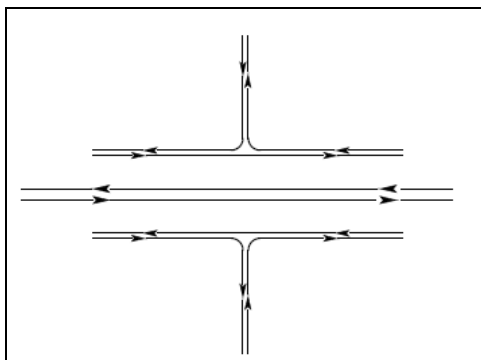

Figure 8: Connection to service road.

Table 5: Recommended access control type of intersecting highways zone in final stage based on highway classification.

Highway Category ⁽¹⁾	Freeway				
Freeway	A	Urban Freeway			
Urban Freeway	A	A	Major Highway		
Major Highway ^(2,3)	A or B	A or B	B	Minor (Regional) Highway	
Minor (Regional) Highway	B or E	B or E	B or C or D1 or D2 with right turning roadway	B ⁽⁴⁾ or C or D (D1, D2, D4)	Local and access road
Local and access road (low-volume roads)	E or F	E or F	C or D2 with right turning roadway or F	C or D (D1, D2, D4)	D (D2, D3, D4)
Urban Arterial	E	B or E	B or D1	B or D (D1, D4)	D

Clarifications to Table 4:

- (1) Highway classifications characteristics are presented in Israel Country Report (Bassan et al. 2015). Typical characteristics of highways' categories with interchange relevance in Israel are presented in Appendix A.
- (2) Major highway is always divided (2-way) in its final stage of construction.
- (3) Design speed of 110 km/hour (or target speed of 100 km/hour) necessitates fully interchanged major divided highway (by A or B or C). Intersecting zone type of both major highways would be service interchange (B) in final stage of construction and signalized intersection (D) in intermediate stage of construction.
- (4) Assuming both regional highways are divided (two-way) in the final stage of construction.

SYSTEM CONSIDERATIONS OF COMPACT GRADE SEPARATED JUNCTION (CGSJ) ON MAJOR HIGHWAYS

Major (divided) highways have an important role in the interurban highway system. The highway transfers considerably high traffic volumes but enables limited access to adjacent land-use and suburban areas.

In general, the access to the major highway is implemented by signalized intersections or un-signalized intersections or by solitary right turns or by compact grade separated junctions. Employing multiple intersections with left turns along the major highway might influence traffic flow by causing delays to the passing interurban traffic and safety difficulties. Safety issues could engage side-front vehicle crashes, and pedestrian injuries while crossing the intersection in order to reach a bus-stop. Also, a decrease of air pollution can be gained due to waiting time of non-electric vehicles in reduced number of signalized intersections along the highway corridor.

Typical solutions for alleviating traffic flow and safety could be as follows:

- 1) Implementing compact grade separated junctions (CGSJs).
- 2) Supplementing service roads between intersections which are connected to residential or commercial areas.
- 3) Integration of CGSJs and service (frontage) roads by providing access to land-use and as a result, connecting service roads to CGSJs and converting other adjacent (full) intersections to solitary right turn intersections. The highway engineer could therefore consider implementing CGSJ (i.e. with grade separation) instead of the at-grade existing nearby intersections which necessitate left turn movements.
- 4) Applying signalized intersections with relatively distant spacings (above 2.0 kilometers) and converting other adjacent intersections (which are located between the signalized intersections) to solitary right turn intersections. Moreover, access (minor) roads, could be physically separated from the major highway by connecting them to service roads.

Figure 9 presents a schematic solution of improving traffic flow along the major (two-way) divided highway. According to this typical example two central intersections were converted to CGSJ with a service road which is connected to the minor roads. Two external intersections were converted to right-turns' intersections with pedestrian overpass or underpass. The additive travel length for arrival to the access roads (leading to residential or commercial zone) can be 6 kilometers (3 kilometers plus 3 kilometers back and forth respectively) or equivalently 4.5 minutes of traveling in target speed of 80 km/hour (Bassan

2016). The traffic delays of passing the inner withdrawn intersections should be reduced accordingly from the additive travel time.

OPERATIONAL AND SAFETY INSIGHTS

The capacity and traffic operation limitations of signalized intersection are a dominant warrant to convert it to an interchange or to a compact grade separated junction (CGSJ). When the LOS of certain movements within the intersection becomes E or F and most focused traffic engineering and safety improvements have been examined (such as adding lanes, separation of right turns, staggered intersection etc.), the implementation of CGSJ or interchange might be considered.

Potential delays, conflicts of crossing movements and left turn maneuvers, and collisions in high volume at-grade intersections might incur costs in terms of waiting time, operating and maintenance vehicle costs (fuel, tires, repairs, vehicle wear) and particularly traffic accidents. The conversion to an interchange or to CGSJ has a certain construction cost but should impact the costs due reduction of delays and interruption to traffic flow, reduction of acceleration, deceleration and braking maneuvers, and reduction of collision damage and fatalities. The travel distance is usually higher in an interchange, however, reduction of delays compromises on this issue.

As far as interchange is preferred, the interchange spacing influences the operational and safety performance of highway system. Freeway collision rates might also increase as interchange spacing decreases, especially in the suburban and urban areas. Sufficient interchange spacing should be determined by the distance required for weaving maneuvers, speed change lanes, (auxiliary lanes), and the applicable placement of directional and message signs.

A detailed economic analysis enables to determine the optimal stages of construction of a new interchange. An interchange and also CGSJ may be a more cost effective alternative than a signalized intersection in replacing a non-signalized intersection under typical rural or suburban highway conditions.

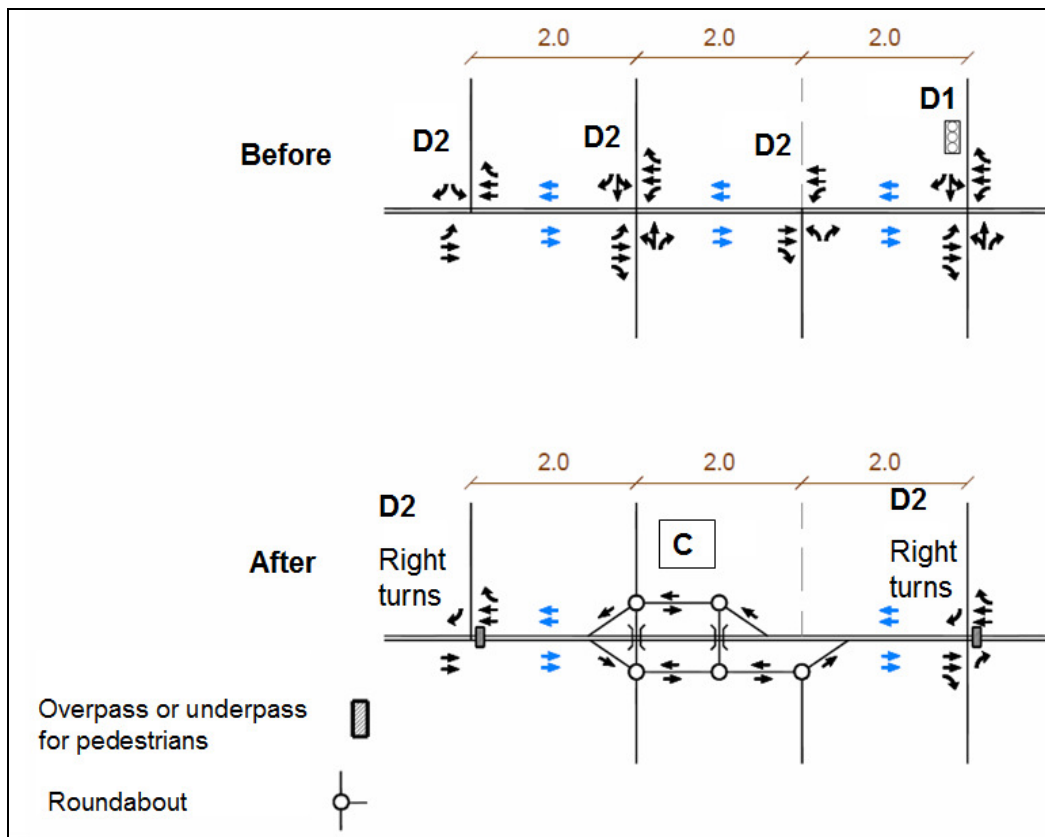

Figure 9: Typical example of system improvements of traffic flow along a major (two-way divided) highway with compact grade separated junction.

SUMMARY

The paper presents criteria of interchange classification such as number of legs, functionality level in the highway system and partiality level. These principles are utilized to generate a systematical warrant for interchange construction. This qualitative warrant which is related to highway classification and access traffic control, indicates which access control types (of the intersecting highways' zone) are suitable for a specific category of two crossing highways in the interchange.

The proposed access traffic control solutions are: (A) System (major) interchange, (B) Service (access, minor) interchange, (C) Compact grade-separated junction (CGSJ), (D) Intersection, (E) Grade separation and (F) Connection to service road. The major interchange can be integrated on freeways and urban freeways; the minor interchange can be integrated on freeways, urban freeways, major highways, and minor highways; and the compact grade separated junction can be implemented on major highways and minor highways.

The paper also **evaluates** system considerations of CGSJ on major highways. Dissolution of the intersection by CGSJ or interchange will alleviate traffic flow on the major highway by recovering the conflicts of crossing movements and left turn maneuvers. On heavily trafficked rural highways, particularly accompanied by land-use development, collision rates cannot be reduced by focused geometric or by traffic control improvements of the intersection. In such cases CGSJ (relatively inferior interchange) might be preferred due to lower construction cost than a conventional interchange.

CONCLUSION

After an appropriate access control solution is determined (particularly the selection between an interchange, CGSJ, or signalized intersection), the highway engineer should evaluate several alternative configuration solutions and decide on the most feasible one based on operation (traffic flow), safety, and economic considerations.

Geometric design and traffic engineering principles as well as freeway system considerations such as: maintaining single exit from each direction of travel, maintaining exits and entries from the right, maintaining appropriate sight distance for drivers approaching the interchange (Bassan 2022), keeping basic lanes and lane balance criteria, proper design of: weaving sections, acceleration and deceleration lanes' length, ramps' influence zones (merge/diverge), consistency of interchange components, and avoiding changing lanes for continuing the through route (*i.e.* route continuity (Leisch 1977, Kozlovsky 2019)) are crucial for the operational and safety performance of interchanges in the highway system. Also, road safety audits (RSAs) during preliminary and detailed design stages might improve the design of simple minor (service) interchanges or major (system) interchanges and complex interchanges as an integral part of the interurban highway system. Finally, integrating public transport elements and pedestrian infrastructure on the interchange components should contribute to the traffic flow of bus rapid lines in the interurban highway system specifically: freeways, urban freeways, and major highways with arrangement of passenger convenient transfers between bus-stops in the interchange zone.

REFERENCES

- (1) AASHTO 2018. A policy of geometric design of highways and streets. 7th edition.
- (2) AASHTO 2011. A policy of geometric design of highways and streets. 6th edition.
- (3) Abreu e S., J., Bazrafshan, H., 2013. User satisfaction of intermodal transfer facilities in Lisbon, Portugal: analysis with structural equations modeling. *Transp. Res. Rec. J. Transp. Res. Board* 2350, pp. 52-57. <http://dx.doi.org/10.3141/2350-12>.

- (4) Bared J.G., Powell A., Kaiser E. Traffic planning models for single point and tight diamond interchanges. *Transp. Res. Rec. J. Transp. Res. Board* 1847, pp. 102–110.
- (5) Bassan S. 2022. Country report Israel: interchange design guidelines in Israel. 6th International Symposium on Highway Geometric Design. Amsterdam, Netherlands.
- (6) Bassan S. 2016. Highway design policy insights for target speed: an Israel perspective. *Traffic Engineering and Control*, 57(4), pp. 155- 158.
- (7) Bassans S., Zilbershtein R., Frischer B. 2015. Israel Country Report. 5th International Symposium on Highway Geometric Design. Vancouver, Canada.
- (8) Bowers S.P. 2011. All Change? Motorway interchanges for public transport. *Proceedings of the Institution of Civil Engineers. Transport Vol. 164 Issue TR4*. Pp. 209-220.
- (9) Design Manual for Roads and Bridges (2022): CD 122. Geometric design of grade separated junctions. UK.
- (10) Doctor M., Merritt G., Moler S. 2009. Designing complex interchanges. *Public Roads*. Vol. 73. No. 3. pp. 1-15. FHWA-HRT -10-001.
- (11) Fowler, B. C. (1993) An Operational Comparison of the Single-Point Urban and Tight-Diamond Interchanges. *ITE Journal*, Vol. 63, No. 4, pp. 19-24.
- (12) Hamaoka H., Matsubara R. 2019. Cause of wrong way driving on expressway by the classification of its pattern. *Journal of the eastern Asia society for transportation studies*. Vol. 13. pp. 2027-2037.
- (13) Hernandez S., Monzon A., de Oña R. 2016. Urban transport interchanges: A methodology for evaluating perceived quality. *Transportation Research Part A*. Vol. 84. pp. 31-43.
- (14) IRC 92. 2017. Guidelines for the design of interchanges in urban areas. Indian Roads Congress.
- (15) Jones E.G., Selinger M.J. 2003, Comparison of operations of single-point and tight urban diamond interchanges, *Transportation Research Record*, vol. 1847, no. 1, pp. 29–35, Transportation Research Board.
- (16) Kozlovsky R. 2019. Forking path: De-scripting interchange architecture at the Ayalon crosstown expressway. *Frontiers of Architectural Research* 8, pp. 332-347.

- (17) Leisch J.E. 1977. dynamics of highway design for safety. *Transportation* 6, 71-83.
- (18) Leisch, J. P., T. Urbanik T. II, and Oxley. J.P. (1989). A Comparison of Two Diamond Interchange Forms in Urban Areas. *ITE Journal*, Vol. 59, No. 5, pp. 21-27.
- (19) Li Y., Zhao X., He Q., Huang L., Rong J. 2018. Comprehensive Evaluation and Classification of Interchange Diagrammatic Guide Signs' Complexity. *Journal of advanced transportation*. Volume 2018, Article ID 9865305, 11 pages. <https://doi.org/10.1155/2018/9865305>.
- (20) Lopez-Lambas, M.E., Monzon, A. 2010. Private funding and management for public interchanges in Madrid. *Res. Transp. Econ.* 29, 323–328. <http://dx.doi.org/10.1016/j.retrec.2010.07.041> (Reforming Public Transport throughout the World).
- (21) Sadia R., Polus A., 2013. Interchange Complexity Model and Related Safety Implications. *Journal of Transportation Engineering*. Vol. 139. pp. 458-468. American Society of Civil Engineers.
- (22) Selinger M.J., Sharp W.H. 2000. Comparison of of SPUI and TUDI Interchange Alternatives With Computer Simulation Modeling. *ITE 2000 Annual Meeting and Exhibit, Nashville, Tenn.*
- (23) Terzis, G., Last, A., 2000. GUIDE. "Urban Interchanges – A Good Practice Guide" (Final Report), European 4th RTD Framework Program.
- (24) TAC-ATC 2017. Transportation Association of Canada. Geometric design guide for Canadian Roads. Chapter 10: Interchanges.
- (25) Yue. R., Yang G., Tian Z., Xu H., Lin D., Wang A., 2019. Microsimulation Analysis of Traffic Operations at Two Diamond Interchange Types. *Journal of advanced transportation*. Volume 2019, Article ID 6863480, 11 pages. <https://doi.org/10.1155/2019/6863480>.

Appendix A

Appendix A: Israel interurban highway characteristics: design speed, cross-section, and interchange implementation

Highway Characteristics	Highway category				Local (access) road
	Freeway	Urban freeway	Major highway	Minor (regional) highway	
Design speed (km/hour)	100-120	90-110	Divided: 80-110 ⁽¹⁾ Two lane: 60-80	Divided: 80-100 ⁽¹⁾ Two lane: 60-80	60-80
Interchange implementation	System interchange, minor interchange	System interchange, minor interchange	Minor interchange, CGSJ	Minor interchange, CGSJ	-
Number of ways (road)	2 (at least)	2 (at least)	2 (usually) 1 (occasionally)	1 (usually) 2 (occasionally)	1
Lane width (m)	3.6 or 3.7 (120 km/hour)	3.6	3.6	3.6 (80 km/hr) 3.5 (70 km/hr) 3.3 (60 km/hr)	3.0-3.5 (60-80 km/hr) ⁽²⁾
Right shoulder width (m)	3.5 ⁽³⁾	3.0	3.5 ⁽³⁾	3.0 (80 km/hour) 2.0/2.5 (60/70 km/hr)	2.0
Left shoulder width (m) : divided highway only	1.2 (2 lanes per direction) 3.0 (3 or more lanes per direction)	1.2 (2 or 3 lanes per direction) 3.0 (4 or more lanes per direction)	1.2 (2 lanes per direction) 3.0 (3 or more lanes per direction)	1.2 (2 lanes per direction) 3.0 (3 or more lanes per direction)	-

⁽¹⁾ For highways with interchanges: 80-110 km/hour: For highways with intersections: 80-100 km/hour.

⁽²⁾ Lane width of 3.0 m for low-volume roads.

⁽³⁾ Alternatively: 3.0 meters with emergency lay bays on the right.