

**Review Article**

Modeling the Yield of *Glycine max* (L.) Merrill Using Mixture Process Variable Model within an Optimal Split-Plot Design

**Abstract**

A mixture design has become famous in statistical modeling in a mixture process variable experiment owing to its usefulness in modeling the blending surface that predicts the response of any mixture empirical. The mixture blends included Manure from cows, chickens, goats, and sheep while the process variable was seeding rate of *Glycine max* seeds and the pH of the soil. The effect of variety of the seed used was established through variation of seeds per acre with uniform application of organic and inorganic fertilizer. This study's main aim was to determine the best desirable split-plot design for performing the *Glycine max* experiment with the settings mixture-process variables. The split-plot design (SPD) was used to solve the problem restricted randomization. It constituted a simplex centroid design (SCD) of four design points of mixture components and 2<sup>2</sup> factorial design with a central composite design (CCD) of the process variable. We formulated a new Scheffe model and the proposed design for SPD for the combined second-order mixture process variable model with CCD. We used the restricted maximum likelihood method to approximate values for *P* parameter models within the SPD. We also found the effect of mixture component at vertices of components of the mixture plus with interaction effect between mixture and process variable to have the highest impact on the growth and pod development of *Glycine max*. The optimum total yield of *Glycine max* for variety R184 and Blyvoor used in Bushel per acre was 180.53 and 219.2472, respectively on the whole plot with a pH of soil being 5.4. The mean response maximum optimum yield for the total number of pods per plant and seeds per pod of *Glycine max* were found to be 32.30 and 2.331, respectively. We recommend using SPDs in experiments involving mixture settings formulations to measure the interaction effects of both the mixture components and the processing conditions like a pH of the soil and seeding rate.

**Keywords:** Process variable, Mixture design, Simplex centroid design, Split plot design, Soil pH

**1.0 Introduction**

A mixture design has become popular in statistical modeling in a mixture process variable (MPV) experiment owing to its usefulness in modeling the blending surface that predicts the response of any mixture empirical (Cook et al., 2004; Cho, 2010; Njoroge et al., 2017; Sitinjak, M. A., and Syafitri, 2019). In MPV, the response is a function of the mixture part proportion and the process variable. The explanatory variable and response in mixture experiments are dependent only on the relative proportion of the mixture ingredient, not on the mixture's volume. (Cornell, 1988; Goldfarb et al., 2003). Process variables are variables that do not make up a portion of the

Formatted: Font:  
Formatted: Font:  
Formatted: Font:  
Formatted: Font:  
**Comment [.1]:**  
Suggestions:  
1) The manuscript should be prepared based on the Author Guidelines.  
2) The manuscript should be proofread by a Native Speaker.  
Formatted: Font:  
Formatted: Font:

Formatted: Font: 16 pt

mixture in an experiment but influence the ingredients' blending properties when their levels are modified. (Cho, 2010; Goos and Donev, 2007).

*Glycine max* is known as a leguminous seed. It contains a high percentage of high-quality protein (40-42) and oil (18-20%), and other nutrients such as calcium, iron, and glycine which helps to prevent diseases like heart disease, cancer, and a slew of others, according to Jackson (2016). It also improves soil fertility by fixing significant atmospheric nitrogen levels by root nodules and leaf fall on the ground at maturity.

*Glycine max* production in Kenya is still inadequate, according to Mahasi et al. (2011), averaging 2000-5000 metric tons per year. However, due to functional and economic considerations, some process variables (noise variables) are challenging to modify in some cases. According to Goldfarb et al. (2004b), these limitations prevent complete randomization of the experimental runs. Incomplete randomization of experimental runs has become one of the leading causes of cereal crop yield declines. Many researchers (Chad Lee and Herbek, 2005; Lee et al., 2008; Tiftonell et al., 2008; Wanyama, 2013) believe that other variables are also to blame if they are not well considered, such as seed row spacing, seeding rates, soil nutrient management strategies, soil pH. Some factors mentioned above, such as soil pH, row spacing, and seeding rate, are examples of the process variables affecting the optimum yield of the crop if not well managed (Pedersen, 2004).

In Africa, natural soil fertility is addressed by applying nitrogen, phosphorus, and potassium fertilizers at low rates. There is always a general expected response of cereals to NPK fertilizer application at current recommendations. However, the response remains far below the potential level, particularly on-farm due to nutrient deficiencies and imbalances. The predicted responses of *Glycine max* to N, P, and K, as well as the scale of macronutrient (N, P, and K) and micronutrient (Zinc) deficiencies, have been studied and reported in Kenyan Soybean (*Glycine max*) growing areas. However, there has been little investment in research to determine the best method of combining mixture components with simplex centroid design (SCD) of organic fertilizers derived from livestock manure within split-plot design (SPD) using a  $2^k$  factorial configuration with a central composite design (CCD) of the process variable. As a result, this study evaluates the impact of MVP design on *Glycine max* production using farm trials in a SPD. The SPD is used to solve the problem of restricted randomization on mixture-process variable layouts in this case.

## 2.0 Research Methodology

### 2.1 Data source

The data was primarily collected from the field of experiment. The data consist of two response measurements obtained from *Glycine max* (L.) Merrill. The two responses measured includes the number of entire pods per plants ( $\eta_1$ ) and seeds per pod ( $\eta_2$ ). The mixture settings included four components  $x_1, x_2, x_3,$  and  $x_4$ , derived from different organic matter varieties, which represent goat manure, cow manure, chicken manure, and sheep manure, respectively. The mixtures were the subplots and process variables the whole plots. The model for the fixed part of this experiment is represented in model (1).

Comment [.2]: Correct?

Formatted: Font: (Default) Times New Roman

Formatted: Font: (Default) Times New Roman

Formatted: Font:

Formatted: Font:

Formatted: Font: (Default) Times New Roman, 11 pt

Formatted: Font: (Default) Times New Roman, 11 pt

Formatted: Font: 11 pt

Formatted: Font: 11 pt

Formatted: Font: 11 pt

Formatted: Font: 11 pt

Formatted: Font: 11 pt

Formatted: Font: 11 pt

Formatted: Font: 11 pt

Formatted: Font: 11 pt

Formatted: Font: 11 pt

Formatted: Font: 11 pt

Formatted: Font: 11 pt

Formatted: Font: 11 pt

## 2.2 Description of experimental sites

The study was conducted in Spande and Munge's villages in Kakamega County, Mautuma Ward, Lugari Sub-District, and Western Kenya. Both sites are about 8 km apart. The two regions lie between (0.706373°N, 35.0722°E) and (0.695366°N, 35.028022°E), with an elevation of between 1800 and 1900 m above sea level, respectively. The region receives bimodal rains with an annual mean precipitation of about 1971 mm, and an annual mean temperature of about 20.4°C, as reported by Althof (2005) and Mbau et al. (2015). Additionally, prolonged rain usually occurs between April and July, while short precipitation occurs between August and December, as described by Mbau et al. (2015). Further, the reliability growth period for *Glycine max* (L.) Merrill lies between 75 and 140 days (Jaetzold et al., 2005).

Table 11: Shows the MPV settings in the context of SPD

Run	Whole plot	X <sub>1</sub>	X <sub>2</sub>	X <sub>3</sub>	X <sub>4</sub>	Z <sub>1</sub>	Z <sub>2</sub>
1	1	0.25	0.25	0.25	0.25	-1	1
2	1	0	0	0	1	-1	1
3	1	0	1	0	0	-1	1
4	1	0.25	0.25	0.25	0.25	-1	1
5	1	0	0	1	0	-1	1
6	1	1	0	0	0	-1	1
7	2	0.25	0.25	0.25	0.25	1	-1
8	2	0.25	0.25	0.25	0.25	1	-1
9	2	0	0	1	0	1	-1
10	2	0	1	0	0	1	-1
11	2	0	0	0	1	1	-1
12	2	1	0	0	0	1	-1
13	3	0.5	0.5	0	0	1	1
14	3	0.5	0	0.5	0	1	1
15	3	0.5	0	0	0.5	1	1
16	3	0	0.5	0	0.5	1	1
17	3	0	0.5	0.5	0	1	1
18	3	0	0	0.5	0.5	1	1
19	4	0	0.5	0.5	0	-1	-1
20	4	0.5	0.5	0	0	-1	-1
21	4	0	0	0.5	0.5	-1	-1
22	4	0.5	0	0.5		-1	-1
23	4	0.5	0	0	0.5	-1	-1
24	4	0.25	0.25	0.25	0.25	-1	-1
25	5	1	0	0	0	0	0
26	5	0	1	0	0	0	0
27	5	0	0	1	0	0	0
28	5	0	0	0	1	0	0
29	5	0.25	0.25	0.25	0.25	0	0
30	5	0.25	0.25	0.25	0.25	0	0
31	6	0.5	0	0.5	0	0	1
32	6	0.5	0.5	0	0	0	1
33	6	0.5	0	0	0.5	0	1
34	6	0	0.5	0.5	0	0	1
35	6	0	0.5	0	0.5	0	1
36	6	0	0	0.5	0.5	0	1
37	7	0.5	0	0.5	0	0	-1
38	7	0.5	0.5	0	0	0	-1
39	7	0.5	0	0	0.5	0	-1
40	7	0	0.5	0.5	0	0	-1
41	7	0	0.5	0	0.5	0	-1
42	7	0	0	0.5	0.5	0	-1
43	8	0.25	0.25	0.25	0.25	-1.414	0
44	8	0.25	0.25	0.25	0.25	-1.414	0
45	8	0.25	0.25	0.25	0.25	-1.414	0
46	8	0.25	0.25	0.25	0.25	-1.414	0
47	8	0.25	0.25	0.25	0.25	-1.414	0
48	8	0.25	0.25	0.25	0.25	-1.414	0
49	9	0.25	0.25	0.25	0.25	1.414	0
50	9	0.25	0.25	0.25	0.25	1.414	0
51	9	0.25	0.25	0.25	0.25	1.414	0
52	9	0.25	0.25	0.25	0.25	1.414	0
53	9	0.25	0.25	0.25	0.25	1.414	0
54	9	0.25	0.25	0.25	0.25	1.414	0

Further, as Isaev et al. (2020), the best period for sowing *Glycine max* is when the temperature in the 0 – 10 cm layer of soil is about 12 – 14°C. According to Tsikhungu et al. (2016), the Lugari sub-county grounds are predominantly well-drained deep red to dark, sandy loams to sandy clays that are not very fertile. Still, well-drained soils with moderately to slightly condition

Formatted: Font:

Formatted: Font: (Default) Angsana New

Formatted: Font: Angsana New

Formatted: Font: (Default) Angsana New

Formatted: Font: (Default) Angsana New

Formatted: Font: (Default) Times New Roman

Formatted: Font: Italic

Formatted: Font: Italic

Formatted: Font: Italic

Formatted: Font: (Default) Times New Roman, 11 pt

Formatted: Font: (Default) Times New Roman

Formatted: Font: (Default) Angsana New

with soil pH, lie between 5.3 to 5.9. However, some part of this region contains low inherent fertility as evidenced by low amounts of Nitrogen, soil organic carbon and exchangeable base as described by Ayuke et al. (2007). The experimental site encompasses farmlands adjacent to the Lugari forest. The area was initially inhabited by a sparse population of former forest residence communities who practiced shifting cultivation, hunting, and gathering. The study sites have a settlement history dating more than a hundred years with relatively intensive sedentary mixed subsistence agriculture as reported by Kimetu et al. (2006) for over the last sixty years. Pender et al. (2006) found that landholding per household has reduced drastically because of the high population growth rate and immigration into the area. Currently, most agricultural land is characterized by low soil fertility, low crop yields, and low farm income (Ayuke et al., 2007). However, cereals (maize), legumes (beans), and sugarcane have become the primary crops, with most fields described by Mbau et al. (2006).

### 2.3 Method of Analysis

We formulated a second order Scheffe polynomial model within SPD as shown in model (1) and Figure 1 by extending the model proposed by Kowalski et al. (2002), Cho (2010) and Njoroge et al. (2017) from 3 to 4 mixture blends in the presences of two process factors as in Equation (1). The process variable in the model were  $Z_1$  and  $Z_2$  where  $Z_1$  the control is process variable (seeding rate (seeds per acre) at a constant row spacing of *Glycine max* seed) and  $Z_2$  is the noise process variable (soil pH).

$$Y(x, z) = \beta_1 X_1 + \beta_2 X_2 + \beta_3 X_3 + \beta_4 X_4 + \beta_{12} X_1 X_2 + \beta_{13} X_1 X_3 + \beta_{14} X_1 X_4 + \beta_{23} X_2 X_3 + \beta_{24} X_2 X_4 + \beta_{34} X_3 X_4 + \vartheta_{11} X_1 Z_1 + \vartheta_{12} X_1 Z_2 + \vartheta_{21} X_2 Z_1 + \vartheta_{22} X_2 Z_2 + \vartheta_{31} X_3 Z_1 + \vartheta_{32} X_3 Z_2 + \vartheta_{41} X_4 Z_1 + \vartheta_{42} X_4 Z_2 + \rho + \varepsilon \quad (1)$$

Where  $\beta_i$  is the vector of fixed effect resulting from mixture blend of the vertices of component  $X_i$ ,  $\beta_{ij}$  is the vector of random effect resulting from the interaction between mixture components,  $\vartheta_{ij}$  is the vector of random effect resulting from the interaction between mixture components and process factors,  $\rho \sim N(0, \sigma_\rho^2)$ , represent the random error associated with the whole-plot factor by itself during the randomization level, and  $\varepsilon \sim N(0, \sigma_\varepsilon^2)$  indicate the random error that is associated with sub plot randomization level. However,  $\sigma_\rho^2$  and  $\sigma_\varepsilon^2$  are assumed to be statistically independent and distributed. The model 1 was formulated basing on the design shown in Figure 1. Figure 1 depicts the newly generated design for SPD to Support Fitting the Combined Second-Order MPV model where the center point  $[z_1, z_2] = \{0, 0\}$ , and  $v, k$  is the number of times that treatment combination is replicated.

The model (1) is an empirical model that corresponds well with the experience and plots of the data. The random component effect of the model has a whole plot and split-plot contribution. The whole plot error is nested under  $x_1, x_2, x_3$ , and  $x_4$ , while the subplot error is the standard residual error term. The model was analyzed using restricted maximum likelihood described in Njoroge et al. (2017) to account for the split-plot random structure.

Formatted: Font:

Formatted: Font: 11 pt

Formatted: Font: 11 pt

Formatted: Font: 11 pt

Formatted: Font: 11 pt

Formatted: Font: 11 pt

Formatted: Font: 11 pt

Formatted: Font: Not Bold, Font color: Auto

Formatted: Font: (Default) Times New Roman

Formatted: Font: 11 pt

Formatted: Font: 11 pt

Formatted: Font: 11 pt

Formatted: Font: 11 pt

Formatted: Font: 11 pt

Formatted: Font: 11 pt

Formatted: Font: 11 pt

Formatted: Font: 11 pt

Formatted: Font: 11 pt

Formatted: Font: 11 pt

Formatted: Font: 11 pt

However, the model (1) under split plot design was further simplified to

$$Y_{jk} = X_{jk} \beta + d_{jk} \delta_j + \varepsilon_{jk} \quad (2)$$

here  $Y_{jk}$  represents whole plot  $j$  at  $k^{th}$  measurement response variable subject to split-plot factors and process variable.  $n_w$  denotes the number whole plot while  $n_j$  number of measurements in whole plot  $j$ .  $d_{jk}$  indicates a covariate vector of  $j^{th}$  whole plot at  $k^{th}$  measurement for random effects  $\delta_j \in \mathbb{R}$  associated with whole plot effect where  $q$  is the number of factor components applied in split plot layout experiment.

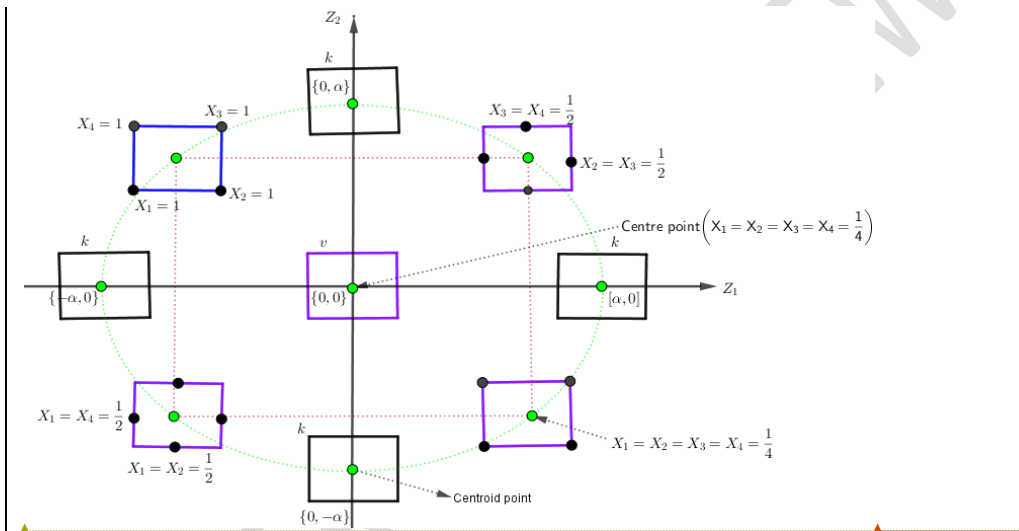

Figure 14: shows a newly developed Design for Split-Plot layout for combined 2<sup>nd</sup> order MPV with CCD.

Figure 1 shows the same design produced in table form shown in Table 1. The design in Table 1 was generated using the candidate set free algorithm described in Jones and Goos (2007) and implemented in JMP version 15.1 (Jones and Sall, 2011) based on the design shown in Figure 1. However, the split plot structure constituted a simplex centroid design (SCD) of four design points of mixture components and 2<sup>2</sup> factorial design with a central composite design (CCD) of the process variable.

#### 2.4 Composting Farmyard manure through the framework of Mixture design

Four agro-organic wastes commonly found in the test sites were selected for our study. The selection criteria for the required farm yard manure (FYM) obtained from livestock were based on the region's availability of material. FYM includes goat manure, poultry manure, sheep manure, and animal manure derived from the Spande farm. Compound composting was done using the pit method using the structure of the mixture design under control

$$x_1 + x_2 + x_3 + x_4 = 1,$$

Formatted: Font: 11 pt

Formatted: Font: (Default) Times New Roman

Formatted: Font: (Default) Times New Roman, Italic

Formatted: Font: (Default) Times New Roman, Italic

Formatted: Font: Italic

Formatted: Font: Italic

Formatted: Font: Italic

Formatted: Font: (Default) Times New Roman

in reference to the design in Table 1. Composting was done in line to the literature using Pit method where each pit was measuring  $3 \times 3 \times 2 \text{ m}$  (Agromisa et al., 2005, Mbau et al., 2008).

### 2.5 Treatment combinations mManure in the context of MPV within SPD

Field trials were performed on two farms. The experiment was carried out using a well randomized complete block in a split-plot arrangement with replication, as shown in Table 1. The split-plot structure comprised nine whole plots, with each field having six sub-plot treatments. Each plot's plot size was  $95.5 \text{ ft} \times 170 \text{ ft}$ , while each experimental subplot unit was  $15.5 \text{ ft} \times 50 \text{ ft}$ . Split plot treatments were applied based on the proposed design in figure 1 using composite compost manure from the 11 compost pits. They were four lime treatments (0, 1.7, 5, and 15 – ton *aglime /acre*) being applied to 9 main plots with at least twice at axial part as shown below with correspondence of soil *pPH* obtained after the application.

Table 22: showing scaled seeding rate ( $Z_1$ ), and soil *pPH* ( $Z_2$ ), according to  $2^2$  factorial design with CCD

Whole plot	Lime application (tons/acre)	Un coded $Z_1$	Un coded $Z_2$	Coded $Z_1$	Coded $Z_2$
1	15	125000	7.0	-1	1
2	1.7	225000	6.0	1	-1
3	15	225000	7.0	1	1
4	1.7	125000	6.0	-1	-1
5	5	175000	6.5	0	0
6	15	175000	7.0	0	1
7	1.7	175000	6.0	0	-1
8	0	100000	5.4	-1.414	0
9	0	275000	5.4	1.414	0

After initial testing of soil pH at the farm was 5.4, we prepared five different soils for selected plant growth at optimal pH values, as shown in Table 2. *pPH* chosen deals from the initial 5.4 pH of the soil using a control method according to the literature (De Bruin and Peterson, 2008):

The whole plots consisted of five primary seeding rates (100000, 125000, 175000, 225000, and 275000 seeds per acre) applied to sub-plot experimental units taking into account row spacing whole plot as shown in Table 2. According to the literature review, we used the seeding rate and row spacing (De Bruin and Pedersen, 2008). The *Glycine max* varieties were R 184, and Blyvoor were planted on April 24<sup>th</sup>, 2020. The seeds were first inoculated with *Bradyrhizobium Japonicum*, and each subplot was grown using row spacing specified in table 2 and 1- inch depth. Plots were harvested on August 27<sup>th</sup>, 2020. Grain yields obtained were then adjusted to 13% moisture.

### 3.0 Result and Discussion

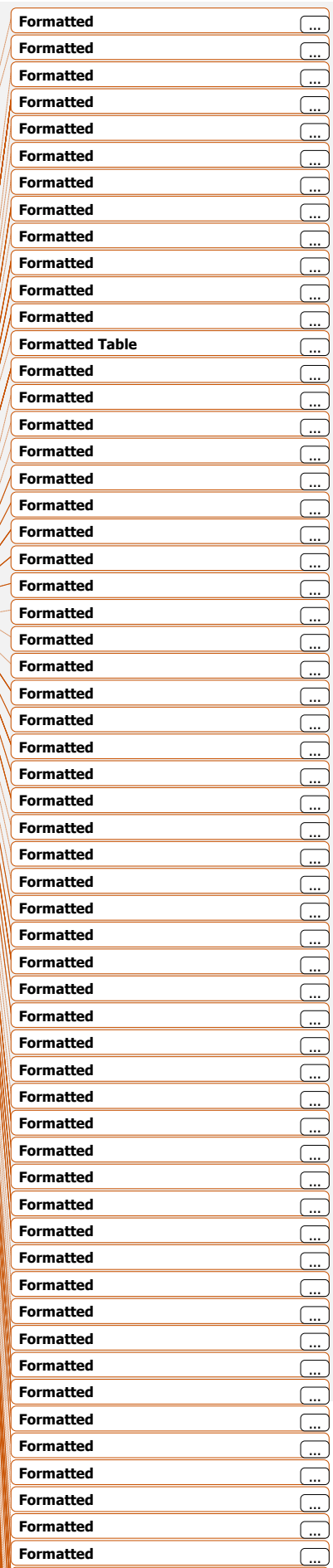



$$\hat{Y} = 21.8741x_1 + 23.3074x_2 + 23.5741x_3 + 21.54074x_4 + 39.36272x_1x_2 + 40.8294x_1x_3 + 47.5961x_1x_4 + 38.9627x_2x_3 + 41.6515x_2x_4 + 38.7299x_3x_4 + 2.9268x_1z_1 \quad (4)$$

Table 44: shows the t student test for the fitted Scheffe model for the Number of seeds per pod of *Glycine max* per plant stem using REML analysis

Term	Estimate	Standard Error	t value	p value
$x_1$	2.0597	0.03460	59.52	0.0001
$x_2$	2.0597	0.03460	59.52	0.0001
$x_3$	2.0597	0.03460	59.52	0.0001
$x_4$	2.0597	0.03460	59.52	0.0001
$x_1x_2$	1.2119	0.10790	11.23	0.0001
$x_1x_3$	1.1119	0.10790	10.30	0.0001
$x_1x_4$	1.1119	0.10790	10.30	0.0001
$x_2x_3$	1.2119	0.10790	11.23	0.0001
$x_2x_4$	1.2207	0.12058	10.12	0.0001
$x_3x_4$	1.0695	0.10491	10.19	0.0001
$x_1z_1$	0.0719	0.03396	2.12	0.0491
$x_2z_1$	0.0426	0.03473	1.23	0.2352
$x_3z_1$	0.7634	0.03400	1.86	0.0546
$x_4z_1$	0.0795	0.03429	2.32	0.0326
$x_1z_2$	0.0431	0.03511	1.23	0.2434
$x_2z_2$	0.0097	0.03581	0.27	0.7916
$x_3z_2$	0.0462	0.03505	1.32	0.2120
$x_4z_2$	0.0492	0.03545	1.39	0.1898

The estimate, standard errors, t values and p values of the fitted Scheffe model for the total number of seeds per pod of *Glycine max* per plant stem observed. The fitted Scheffe model is therefore,

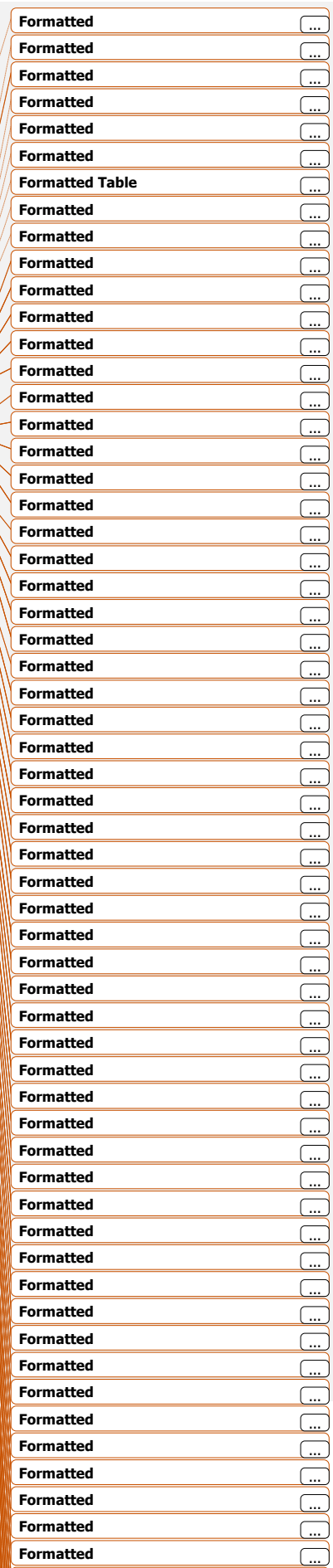

$$\hat{Y} = 2.0597x_1 + 2.0597x_2 + 2.0597x_3 + 2.0597x_4 + 1.2119x_1x_2 + 1.1119x_1x_3 + 1.1119x_1x_4 \quad (5)$$

$$+ 1.2119x_2x_3 + 1.2207x_2x_4 + 1.0695x_3x_4 + 0.0719x_1z_1 + 0.0426x_2z_1$$

$$+ 0.0634x_3z_1 + 0.0795x_4z_1 + 0.0431x_1z_2 + 0.0097x_2z_2 + 0.0462x_3z_2$$

$$+ 0.0492x_4z_2$$

Formatted ...

Formatted ...

The significant factors were  $x_1, x_2, x_3, x_4, x_1x_2, x_1x_3, x_1x_4, x_2x_3, x_3x_4, x_1z_1$  and  $x_4z_1$ , as shown in table (4). Thus, the final model is

Formatted ...

$$\hat{Y} = 2.0597x_1 + 2.0597x_2 + 2.0597x_3 + 2.0597x_4 + 1.2119x_1x_2 + 1.1119x_1x_3 + 1.1119x_1x_4 \quad (6)$$

$$+ 1.2119x_2x_3 + 1.2207x_2x_4 + 1.0695x_3x_4 + 0.0719x_1z_1 + 0.0795x_4z_1$$

Formatted: Font: 11 pt, Font color: Auto

Formatted ...

Formatted ...

The results shown in Table 3 and 4 were obtained by using a REML. The results in both tables clearly shows that  $x_1, x_2, x_3, x_4$  and all the interaction  $x_1x_2, x_1x_3$  and  $x_1x_4$  are all significant and have a great impact on the number of pods on the main stem per plant. Also, the interaction between the process variable and mixture component factor  $x_1z_1$  and  $x_4z_1$  are significant at 5%. However, we can also observe that the interaction between  $x_3z_1$  and  $x_2z_2$  are almost significant at the same level with  $p = 0.0546$  and  $0.0516$ , respectively. Further, this is indicating a possible effects of the mixture process variable interaction resulting from soil PH ( $z_2$ ) and the number of seeds used per acre ( $z_1$ ). The whole plot error variance and sub-plot error variance was found to be 0.0048252 and 0.0018023, respectively corresponding to 2.677 Variance ratio ( $d = \frac{\sigma_{\alpha}^2}{\sigma_{\epsilon}^2}$ ) with Wald  $P$  - value = 0.109. This shows that random effect resulting from MPV interaction was not significant at 5% level and therefore, restricted randomization was completely solved with SPD.

Formatted ...

Table 5: shows the summary fit of the two responses obtained using MPV setting model structure

Summary of fit	Pods per plant	Seeds per pod
Multiple $R^2$	0.9857	0.9711
Adjusted $R^2$	0.9790	0.9575
Mean response	32.30	2.331

Formatted ...

Formatted Table

Formatted: Centered, Space After: 0 pt

Formatted: Centered, Space After: 0 pt

Formatted: Centered, Space After: 0 pt

Formatted Table

Formatted: Centered, Space After: 0 pt

The averagedly adjusted  $R^2$  from table 5 shows that 96.83% of the variation in the response was explained by the model. The result shows clearly that the model fits the data well for the two responses. Also, the results indicate that the second-order MPV model (1) formulated adequately represents the growth and pod development of *Glycine max*. We can also observe that the model has a reliability of 96.83% on averagedly which can also provide some vital information regarding

germination of *Glycine max*. The result also shows that average number of pods per plant and number of seeds per pod is 32.30 and 2.331, respectively.

Table 66: Estimation of *Glycine max* yield of variety two (Blyvoor and R 184) in Bushel per acre max

Whole plot	$\eta_0$	$\eta_{1B}$	$\eta_{2B}$	$\eta_{1R}$	$\eta_{2B}$	Bushels per acre for Blyvoor	Bushels (1 bushel = 25.4 Kg) per acre for R 184
1	125000	32,2	2,4	31,2	2,3	64,4	59,8
2	225000	32,6	2,4	31,6	2,3	117,36	109,02
3	225000	37,9	2,5	36,9	2,4	142,13	132,84
4	125000	29	2,3	28	2,3	55,58	53,67
5	175000	33,2	2,4	32,2	2,3	92,96	86,4
6	175000	35,1	2,4	33,9	2,3	98,28	90,97
7	175000	30,5	2,3	29,5	2,3	81,84	79,16
8	100000	40,4	2,5	39,4	2,5	67,33	65,67
9	275000	46	2,6	45	2,7	219,27	180,53

The table 6 shows the predicted *Glycine max* yield per acre in Bushels for each variety basing on the yield obtained from each whole plot in terms  $\eta_0$ ,  $\eta_1$  and  $\eta_2$  that represents plant per acre, Pods per plant and seed per pod, respectively. On the other hand, the subscript *B* and *R* denotes the variety Blyvoor and R 184. We used the formula described in Chad Lee and Jim (2005) to estimate anticipated total yield per acre in Bushel where one bushel of *Glycine max* (L.) Merrill weighs 60 pounds. The result shown in Table 6 indicates the *Glycine max* growth and pod development increase with the application of MPV settings used. Averagely, the variety Blyvoor does well as compared to variety R 184. The result also shows that the maximum *Glycine max* yield of the two variety is directly proportional to the number of plant per acre. In addition, the result also indicates that the variety of the seed used has also the impact on the optimum yield obtained.

#### 4.0 Summary, Conclusions and Recommendations

We formulated the proposed design for a split-plot layout structure for the combined second-order mixture process variable model with CCD. We used the restricted maximum likelihood method to approximate values for *P* parameter models within the SPD. We also found the effect of mixture component at vertices of component  $x_1, x_2, x_3$  and  $x_4$  to have the highest impact on the growth and pod development of *Glycine max* together with permutation interaction of these mixture components at 5 % significance level. The two-process variable used included various seeding rate of two varieties of R 184 and Blyvoor and soil pH. The variety Blyvoor was found to perform better than variety R 184 in terms of the yield of seeds harvested and the same condition mixture setting and PH of soil as evidenced in Tables 5. The optimum total yield of *Glycine max* for variety R184 and Blyvoor in Bushel per acre was 180.53 and 219.27, respectively on the 9<sup>th</sup> whole plot with a pH of soil being 5.4. The two source errors that result

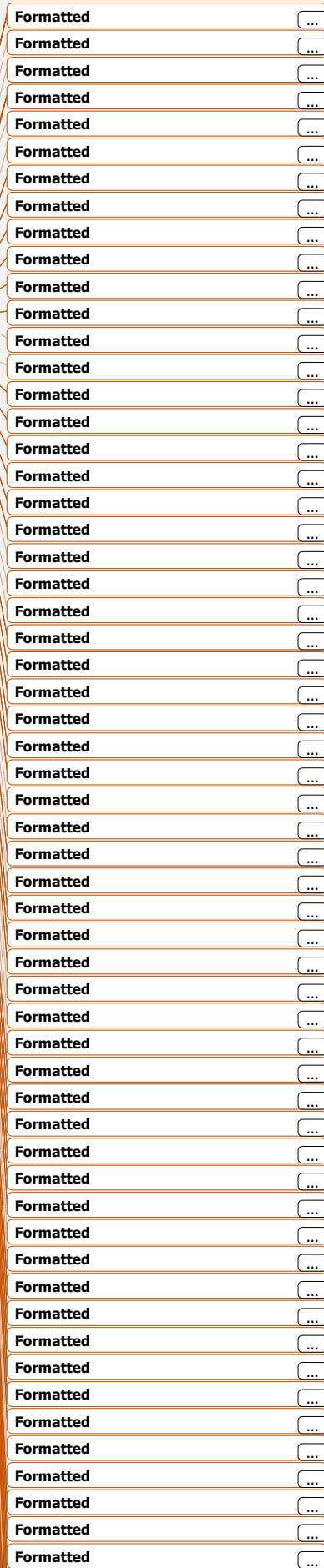

from main treatments (whole plots) and a subplot treatment for each of the two responses were measured and fitted using the same model formulated. We found the average whole plot error variance ( $\sigma_{\delta}^2$ ) and average subplot (split-plot) error variance ( $\sigma_{\varepsilon}^2$ ) to be 0.0048252 and 0.0018023, respectively corresponding to 2.677 Variance ratio ( $d = \frac{\sigma_{\delta}^2}{\sigma_{\varepsilon}^2}$ ) with Wald  $P$  - value = 0.109. Normally, the whole plot error variance larger than the split-plot (Residual) error variance, as shown by Box and Jones (1992). Therefore, this implies that the model adequately represented the mixture data collected from the field, and also, restricted randomization was completely solved with the SPD layout. The least square mean response maximum optimum yield for the total number of pods per plant stem of *Glycine max* was 41.083. We thoroughly investigated the interpretation and estimation of parameters from MPV settings in conjunction with CCD within SPD in the context of the Scheffe polynomial. We recommend using SPDs in experiments involving mixture settings formulations to measure the interaction effects of both the mixture components and the processing conditions like a pH of the soil and seeding rate.

#### REFERENCES

- [1]. Agromisa, Inckel, M., & Tersmette, T. (2005). *The preparation and use of compost* (Vol. 27).
- [2]. Althof, A. J. (2005). Human impact on flora and vegetation of Kakamega Forest, Kenya.
- [3]. Anderson-Cook, C. M., Goldfarb, H. B., Borror, C. M., Montgomery, D. C., Canter, K. G., & Twist, J. N. (2004). Mixture and mixture-process variable experiments for pharmaceutical applications. *Pharmaceutical Statistics: The Journal of Applied Statistics in the Pharmaceutical Industry*, 3(4), 247-260.
- [4]. Ayuke, F. O., Karanja, N. K., Wickama, J., Awiti, A., & Hella, J. (2007). Soil fauna community structure across land management systems of Kenya and Tanzania.
- [5]. Chad Lee and Jim Herbek. (2005). *Kentucky Estimating Soybean Yield, Grain Crops Extension, Plant and Soil Sciences*. University of Kentucky, Kentucky Agricultural Experiment Station.
- [6]. Cho, T. Y. (2010). *Mixture-process variable design experiments with control and noise variables within a split-plot structure*. Arizona State University.
- [7]. Cornell, J. A. (1988). Analyzing data from mixture experiments containing process variables: a split-plot approach. *Journal of Quality Technology*, 20(1), 2-23.
- [8]. De Bruin, J. L., & Pedersen, P. (2008). Effect of row spacing and seeding rate on soybean yield. *Agronomy journal*, 100(3), 704-710.
- [9]. Goldfarb, H. B., Borror, C. M., & Montgomery, D. C. (2003). Mixture-process variable experiments with noise variables. *Journal of Quality Technology*, 35(4), 393-405
- [10]. Goldfarb, H. B., Borror, C. M., Montgomery, D. C., & Anderson-Cook, C. M. (2004b). Three-dimensional variance dispersion graphs for mixture-process experiments. *Journal of Quality Technology*, 36(1), 109-124.
- [11]. Goos, P., & Donev, A. N. (2007). Tailor-made split-plot designs for mixture and process variables. *Journal of Quality Technology*, 39(4), 326-339
- [12]. Isaev S.Kh., Kadirov Z.Z., Khamraev K.Sh., Atamuradov B.N., Sanoev Kh.A. Scientific basis for soybean planting in the condition of grassy alluvial soil prone to salinization. *JCR*. 2020; 7(4): 354-360. [doi:10.31838/jcr.07.04.68](https://doi.org/10.31838/jcr.07.04.68)

Formatted: Font: 11 pt

Formatted: Font: 11 pt

Formatted: Font: 11 pt

Formatted: Font: 11 pt

Formatted: Font: 11 pt

Formatted: Font: 11 pt

Formatted: Font: 11 pt

Formatted: Font: 11 pt

Formatted: Font: 11 pt

Formatted: Font: 11 pt

Formatted: Font: 11 pt

Formatted: Font: 11 pt

Formatted: Font: 11 pt

Formatted: Font: 11 pt

Formatted: Font: 11 pt

Formatted: Font: 11 pt

Formatted: Font: 11 pt

Formatted: Font: 11 pt

Formatted: Font: 11 pt

Formatted: Font: Not Italic

Formatted: Font: Not Italic

Formatted: Font: Not Italic

Formatted: Font: Not Italic

Formatted: Font: Not Italic

Formatted: Font: Not Italic

Formatted: No underline, Font color: Auto

- [13]. Jaetzold, R., Schmidt, H., Hornetz, B., & Shisanya, C. (2006). Farm management handbook of Kenya Vol. II: Natural conditions and farm management information Part C East Kenya Subpart C1 Eastern Province. *Cooperation with the German Agency for Technical Cooperation (GTZ)*.
- [14]. Jones, B., & Goos, P. (2007). A candidate set free algorithm for generating D optimal splitplot designs. *Journal of the Royal Statistical Society: Series C (Applied Statistics)*, 56(3), 347-364.
- [15]. Jones, B., & Sall, J. (2011). JMP statistical discovery software. *Wiley Interdisciplinary Reviews: Computational Statistics*, 3(3), 188-194.
- [16]. Kimetu, J. M., Lehmann, J., Ngoze, S. O., Mugendi, D. N., Kinyangi, J. M., Riha, S., ... & Pell, A. N. (2008). Reversibility of soil productivity decline with organic matter of differing quality along a degradation gradient. *Ecosystems*, 11(5), 726.
- [17]. Kowalski, S. M., Cornell, J. A., & Vining, G. G. (2002). Split-plot designs and estimation methods for mixture experiments with process variables. *Technometrics*, 44(1), 72-79.
- [18]. Lee, C. D., Egli, D. B., & TeKrony, D. M. (2008). Soybean response to plant population at early and late planting dates in the MidSouth. *Agronomy Journal*, 100(4), 971-976.
- [19]. Mahasi, J. M., Mukalama, J., Mursoy, R. C., Mbehero, P., & Vanlauwe, B. (2011). A sustainable approach to increased soybean production in western Kenya. In *10th African Crop Science Conference Proceedings, Maputo, Mozambique, 10-13 October 2011*. African Crop Science Society.
- [20]. Mbatia, S. K., Karanja, N., & Ayuke, F. (2015). Short-term influence of compost application on maize yield, soil macrofauna diversity and abundance in nutrient deficient soils of Kakamega County, Kenya. *Plant and soil*, 387(1-2), 379-394.
- [21]. Njoroge, G. G., Simbauni, J. A., & Koske, J. A. (2017). An optimal split-plot design for performing a mixture-process experiment. *Science Journal of Applied Mathematics and Statistics*, 5(1), 15.
- [22]. Pedersen, P. (2004). Soil pH and plant population effects on soybean yield. *Iowa State University Research and Demonstration Farms Progress Reports*, 2003(1).
- [23]. Pender, J., Place, F., & Ehui, S. (Eds.). (2006). *Strategies for sustainable land management in the East African highlands*. Intl Food Policy Res Inst.
- [24]. Sitinjak, M. A., & Syafitri, U. D. (2019, December). A split plot design for an optimal mixture process variable design of a baking experiment. In *Journal of Physics: Conference Series* (Vol. 1417, No. 1, p. 012018). IOP Publishing.
- [25]. Tittonell, P., Vanlauwe, B., Corbeels, M., & Giller, K. E. (2008). Yield gaps, nutrient use efficiencies and response to fertilisers by maize across heterogeneous smallholder farms of western Kenya. *Plant and Soil*, 313(1-2), 19-37.
- [26]. Tsikhungu, P. W. (2016). Analysis of micronutrients and heavy metals of indigenous reed salts and soils from selected areas in Western Kenya (Doctoral dissertation, Egerton University).
- [27]. Wanyama, W. E. (2013). *Response of soybean (Glycine max L.) to application of inorganic fertilizers, cattle manure and lime in western Kenya* (Doctoral dissertation).

Formatted

Formatted

Formatted

Formatted

Formatted: No underline, Font color: Auto

Formatted

Formatted

Formatted: No underline, Font color: Auto

Formatted

Formatted

Formatted: No underline, Font color: Auto

Formatted

Formatted

Formatted

Formatted: No underline, Font color: Auto

Formatted

Formatted

Formatted

Formatted

Formatted: Font: (Default) Times New Roman