

Original Research Article

Optimization of Operational Parameters for Tractor-Operated Boom Sprayer for Field Crops

ABSTRACT

Spraying is a crucial practice in agriculture, especially for the application of chemical pesticides that play a vital role in protecting crops. However, there has been a worrisome rise in the annual consumption of pesticides, leading to significant concerns. The excessive use of these pesticides has resulted in substantial wastage, which is a cause for alarm. To address these issues and enhance the efficiency of pesticide application, a tractor-operated boom sprayer was developed to ensure uniform spraying. The study focused on evaluating and optimizing three operational factors: spacing between nozzles (30, 40, 50 cm), spray boom height (80, 90, 100 cm), and pressure (17.5, 21.0, 24.5 kg cm⁻²). A Factorial Completely Randomized Design (CRD) approach was employed, 81 experiments (3³×3) were conducted and data were analyzed statistically by using the SPSS software package to investigate the effect of operational parameters on the performance of the sprayer. The results revealed that the operational parameters were significantly influencing the swath width and percent of overlap during spraying. The optimum combination of operational parameters was obtained using the R-software, the optimum combination for obtaining maximum swath width and minimum overlap is spacing between nozzles at 50 cm, spray boom height at 90 cm, and operating pressure at 24.5 kg cm⁻² (s₃-h₂-p₃). The swath width and overlap at optimum combination were 7.77m and 43.124%, respectively. Implementing this optimal combination significantly improved the performance of the spraying activity, ensuring better coverage and reducing potential wastage.

Keywords: Boom sprayer; Factorial CRD; R-software; optimization; Swath width; Overlap.

1. INTRODUCTION

India is the most populous country in the world, where 70% of the total population depends on agriculture for their livelihood [1]. The agriculture sector's contribution to India's GDP decreased from 54% in 1950-51 to 15.4% in 2015-16 [2]. Pests, including pathogens, animals, and weeds, can cause direct yield losses ranging from 20 to 40% of global agricultural productivity [3,4]. The annual estimated production losses due to pests and diseases are \$220 billion globally and \$42.66 million in India [4,5]. Plant protection practices play a critical role in increasing food grain production. The chemical control method is the most effective method of plant protection [6]. Whereas, Excessive use of pesticides can have harmful effects on both the environment and human health [7]. So, the selection of suitable sprayer is important.

In India, knapsack sprayers have emerged as indispensable agricultural tools for small-scale farmers due to their affordability and ease of operation. However, manual spraying with backpack sprayers tends to be highly erratic, resulting in uneven distribution of the pesticide volume [8]. Whereas, the boom sprayer has a wide range of applications in field crops, including maize, soybeans, cotton, green gram, black gram, sorghum, and millets [9].

Tractor-mounted boom sprayers are commonly used in large-scale farming operations to control weeds, pests, and diseases and to fertilize crops. They are available in various sizes and configurations, with some models capable of covering several acres in a single pass. The use of boom sprayers can reduce the time and labor required for chemical application and can improve the accuracy and effectiveness of the application, leading to higher crop yields and reduced costs. Hence, the present study was undertaken to develop a tractor-operated boom sprayer. The developed sprayer has three operational parameters such as nozzle spacing (s), spray boom height (h), and operating pressure (p). Each parameter can adjust at three levels. The determination of a composite optimum combination of operational parameters was important to avoid chemical losses and to improve the performance of the sprayer [10]. In total 81 ($3^3 \times 3$) were carried out for determining the optimum combination at where the effective swath width and overlap were achieved.

2. MATERIALS AND METHODS

2.1 Development of tractor-operated boom sprayer

The tractor-operated boom sprayer was designed and constructed with a main frame that serves as the foundation for various essential components, including a chemical tank, pump, hose pipes, spray boom, and a three-point hitch system. The spray boom was designed with flexibility in mind, allowing for easy attachment and adjustment of nozzles at three different spacing options (30, 40, and 50 cm). Moreover, the main frame featured a mechanism to adjust the height of the spray boom (80, 90, and 100 cm) to suit specific crop conditions. The sprayer offered three pressure settings (17.5, 21.0, and 24.5 kg cm⁻²) to optimize the spray application process. Power for the pump, which had a capacity of 40 L min⁻¹, was supplied by the tractor PTO through a V-belt drive. For chemical storage, the sprayer was equipped with a 400 L capacity tank. To provide a clear understanding of the sprayer's design, a schematic diagram was presented in Fig. 1, while Table 1. displayed the relevant technical specifications considered in the study.

2.2 Evaluation of tractor-operated boom sprayer

In this study, operational parameters, as outlined in Table 2, were selected for evaluation. To conduct the experiments, tap water served as the testing medium for the sprayer. The statistical analysis was performed using a factorial completely randomized design facilitated by the SPSS software package, which allowed for a comprehensive assessment of the effect of the operational parameters on both the swath width and overlap of the sprayer. Additionally, the R-software was utilized to implement a three-factor factorial analysis, enabling the identification of the optimal combination of operational parameters. A total of 81 experiments ($3^3 \times 3$) were carried out to thoroughly evaluate the sprayer's performance under various configurations, with adjustments made to parameters such as nozzle spacing, spray boom height, and operating pressure.

To determine the swath width, the sprayer was operated continuously for two minutes, and the total wetted perimeter was carefully measured as shown in Fig. 1 [10]. For the assessment of overlap, only two nozzles were taken into consideration. In the initial step, one nozzle was operated while the other remained closed, and the resulting wetted perimeter was marked using a colored marker. This process was then repeated with the second nozzle while keeping the first one closed, and the wetted perimeter was again marked, Fig. 2. The area of intersection between the wetted perimeter of both nozzles and the total wetted perimeter was measured, allowing for a precise determination of the overlap.



Fig. 1. Measurement of swath width of the tractor-operated boom sprayer



Fig. 2. Measurement of a spray overlap

Table 1. Technical specifications of developed tractor-operated boom sprayer

Components	Particulars	Details
Source of power	Tractor	35 hp
Tank	HDPE chemical tank	400 L
Pump	Type	Piston-type pump
	Make and Model	Eagle HTP Spray pump
	Recommended rpm	500-1000 rpm
	Required power	2-3 kW
	Suction capacity	40 L min ⁻¹
Nozzle	Maximum pressure	40 kg cm ⁻²
	Number of nozzles	14
	Type	Hollow-cone
	Material	Brass
	Pressure required	14 kg cm ⁻²
	Spray angle	Maximum 90°
	Spray coverage	Maximum 145 cm

Table 2. Plan of experiment to study the effect of operational parameters on swath width and overlap

Variables	Levels	Details	Measured parameters
Spacing between nozzles	3	$s_1=30$; $s_2=40$; $s_3=50$ cm	a. Swath width, m b. Overlap, %
Spray boom height	3	$h_1=80$; $h_2=90$; $h_3=100$ cm	
Pressure	3	$p_1=17.5$; $p_2=21.0$; $p_3=24.5$ kg cm ⁻²	
No. of replications	3		

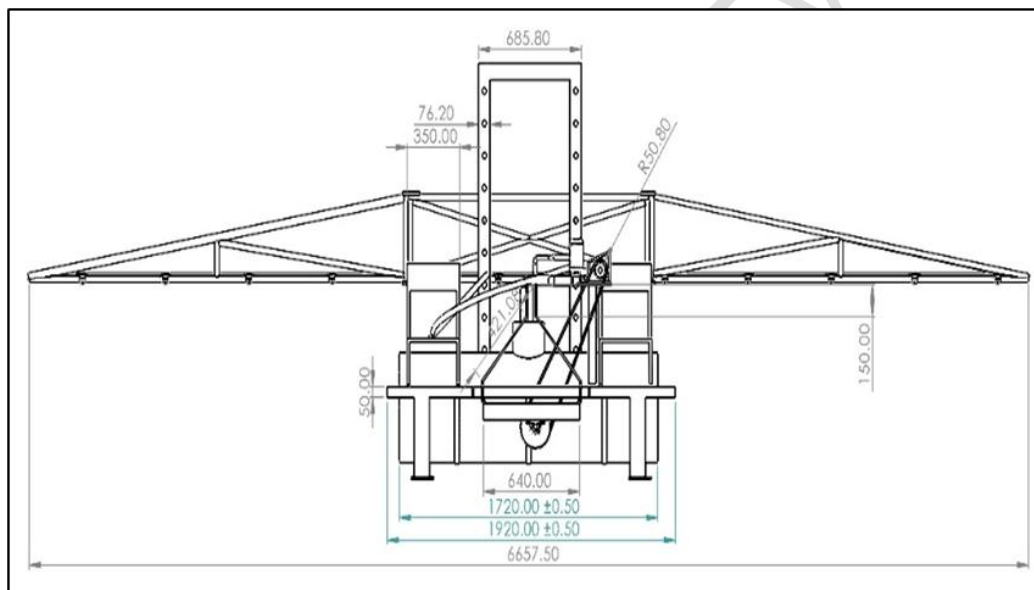

Fig. 3. Schematic diagram of the developed tractor-operated boom sprayer

3. RESULTS AND DISCUSSIONS

3.1 Effect of operating parameters on sprayer performance

The effect of operational parameters on swath width and overlap was shown in Fig. 4 and 5, respectively. The results depicted in the graphical representations unveiled that an increase in nozzle spacing led to a corresponding increase in the swath width, Fig. 4(a). Whereas, the swath width exhibited an initial increase with rising spray boom height, peaking at 90 cm, but then decreased beyond that point, Fig. 4(b). Similarly, the swath width expanded as the operating pressure increased, Fig. 4(c). It was apparent that increasing the nozzle spacing resulted in a decrease in overlap, Fig. 5(a). Similarly, the spray overlap of the sprayer diminished as the boom height increased, Fig. 5(b). However, concerning operating pressure, the overlap initially increased until reaching 21 kg cm⁻², after which it gradually decreased. Fig 5(c). Shows the effect of interaction effects on swath width and overlap.

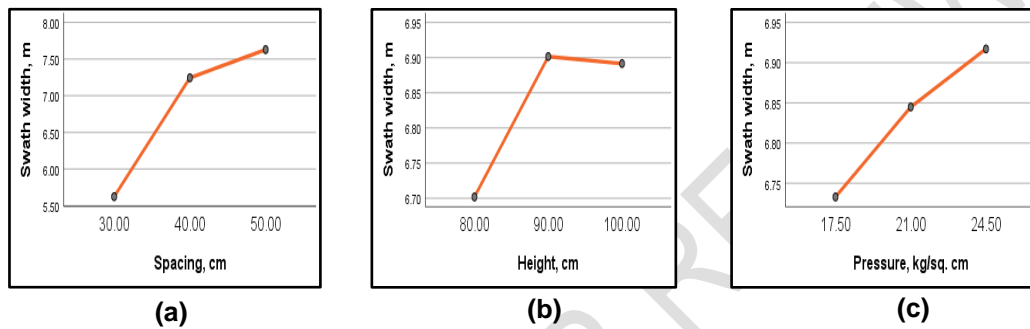

Fig. 4. Effects of operational parameters on swath width (a) Spacing, (b) Height, and (c) Pressure

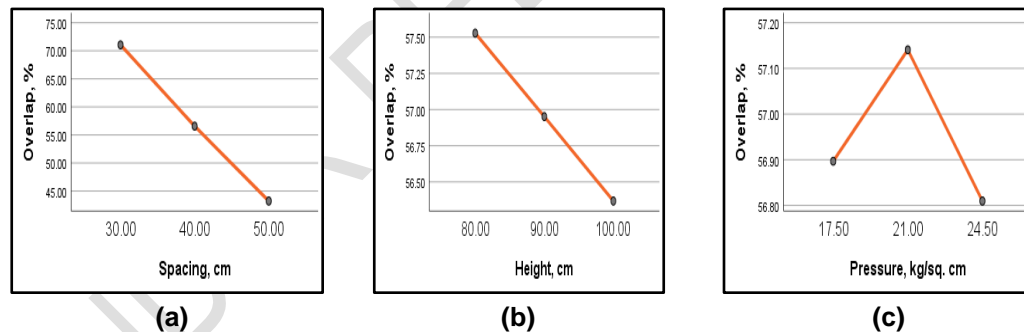

Fig. 5. Effects of operational parameters on overlap (a) Spacing, (b) Height, and (c) Pressure

3.2 Analysis of variance for swath width and overlap

Analysis of variance (ANOVA) was done with the use of SPSS-software package by considering the factorial completely randomized design. ANOVA table for swath width and overlap is presented in Table 3 and 4, respectively. The ANOVA table revealed significant effects of the individual operational parameters on the swath width of the sprayer, with a significance level of 1%. Also, the interactions among the operational parameters showed significant effects on the swath width, except for the interaction between height*pressure. Similarly, both nozzle spacing and height individually exhibited a significant impact on the overlap of the spray, as determined at a 1% level of significance. However, operating pressure did not show a significant effect on the overlap. Further analysis of the interactions

revealed that the interaction between spacing*height, as well as the interaction between spacing*pressure, had significant effects on the overlap at a 1% level of significance. However, the interaction between height*pressure did not demonstrate a significant effect on the spray overlap.

Table 3. ANOVA for the swath width of the sprayer

Source	Sum of Squares	df	Mean Square	F	Sig.
Spacing	61.231	2	30.615	16508.113	.000
Height	.683	2	.342	184.195	.000
Pressure	.464	2	.232	125.229	.000
Rep	.006	2	.003	1.678	.195
Spacing * Height	.161	4	.040	21.648	.000
Spacing * Pressure	.144	4	.036	19.443	.000
Height * Pressure	.006	4	.001	.761	.555
Error	.111	60	.002		
Total	3843.143	81			

Table 4. ANOVA for the overlap of the sprayer

Source	Sum of Squares	df	Mean Square	F	Sig.
Spacing	61.231	2	30.615	16508.113	.000
Height	.683	2	.342	184.195	.000
Pressure	.464	2	.232	125.229	.000
Rep	.006	2	.003	1.678	.195
Spacing * Height	.161	4	.040	21.648	.000
Spacing * Pressure	.144	4	.036	19.443	.000
Height * Pressure	.006	4	.001	.761	.555
Error	.111	60	.002		
Total	3843.143	81			

3.3 Determination of composite optimum combination of the operational parameters

The determination of an optimal combination of operational parameters was conducted through a statistical analysis using the R-programming language. The outcomes of this analysis are presented in Table 4. The operational combination that yielded the most favorable results in terms of swath width and overlap was identified as $s_3-h_2-p_3$, i.e., nozzle spacing of 50 cm, spray boom height of 90 cm, and operating pressure of 24.5 kg cm⁻². This particular combination demonstrated a mean swath width of 7.77 m and a mean spray overlap of 43.124%, affirming its effectiveness.

Table 5. Selection of the optimum combination of operational parameters through R-language

Combination (s_h_p)	Mean swath width (m)	Mean overlap (%)	Groups
50_90_24.5	7.770	43.124	a
50_90_21	7.783	43.931	a
50_100_21	7.697	43.130	b
50_100_24.5	7.667	42.332	bc

50_80_24.5	7.653	42.853	bc
50_80_21	7.603	43.650	cd
50_90_17.5	7.570	43.670	de
40_90_24.5	7.537	56.406	ef
40_100_24.5	7.507	56.801	ef
50_100_17.5	7.493	42.885	f
50_80_17.5	7.420	43.404	g
40_90_21	7.317	56.225	h
40_100_21	7.303	56.653	h
40_100_17.5	7.220	56.324	i
40_90_17.5	7.173	55.926	ij
40_80_24.5	7.130	57.127	j
40_80_21	7.043	56.976	k
40_80_17.5	6.967	56.646	l
30_100_24.5	5.743	70.630	m
30_100_21	5.717	70.470	mn
30_90_24.5	5.697	71.110	mno
30_100_17.5	5.677	70.688	nop
30_90_21	5.643	70.951	op
30_90_17.5	5.623	71.168	p
30_80_24.5	5.550	71.527	q
30_80_21	5.497	71.368	qr
30_80_17.5	5.453	71.585	r

4. CONCLUSION

The analysis of the experimental data revealed that both nozzle spacing and spray boom height had a considerable impact on swath width and overlap individually, with statistical significance at a 1% level of significance. Additionally, the operating pressure showed a significant effect on swath width, but it did not have a significant effect on overlap. The interactions between spacing*height and spacing*pressure demonstrated significant effects on both swath width and overlap. Whereas, the interaction between height*pressure did not exhibit any statistically significant effect on either swath width or overlap at the 1% level of significance. Among all the tested combinations, the optimal setup for achieving effective swath width and overlap was found to be $s_3-h_2-p_3$, corresponding to a nozzle spacing of 50 cm, spray boom height of 90 cm, and operating pressure of 24.5 kg cm⁻². These findings conclusively demonstrated that the identified optimal operational parameters significantly enhanced the overall performance of the spraying operation.

CONSENT

As per international standard or university standard, respondents' written consent has been collected and preserved by the author(s).

REFERENCES

1. Jeeva SRDN, Laloo RC, Mishra BP. Traditional agricultural practices in Meghalaya, North East India. *Indian J Trad Knowl*. 2006;5(1):7–18.
2. Deshpande T. State of agriculture in India. *PRS Legislative Research*. 2017;53(8):6-7.
3. Sharma S, Kooner R, Arora R. Insect pests and crop losses. In *Breeding insect resistant crops for sustainable agriculture*. Springer, Singapore. 2017;45-66.
4. Food and Agricultural Organization of United Nations. Statistical database. 2019. Accessed 24 May 2023.
Available: <https://www.fao.org/faostat/en/#home>.
5. Subash SP, Chand P, Pavithra S, Balaji SJ, Pal S. Pesticide Use in Indian Agriculture: Trends, Market Structure and Policy Issues. ICAR-NIAEP. 2017.
6. Saxena H, Bandi SM, Revanasidda. Sucking Pests of Pulse Crops. *Sucking Pests of Crops*. 2020;107-133.
7. Mahmood, I., Imadi SR, Shazadi K, Gul A, Hakeem KR. Effects of pesticides on environment. *Plant, soil and microbes: volume 1: implications in crop science*. 2016;253-269.
8. Li T, Ni Z, Zhang Y, Shi G, Zhou J. Design and Testing of an Inter-row Sprayer in a Chinese Solar Greenhouse. *Journal of Engineering Science & Technology Review*. 2020;13(3).
9. Pathak SV, Shirsat NA, Shahare PU, Pawar PS. A review study on vertical boom sprayer for orchard. *The Pharma Innovation Journal*. 2021;10(6): 57-59.
10. Srinivasarao A., Khura TK, Parray RA, Mani I, Kushwaha HL, Sarkar SK. Optimization of Operational Parameters for Tractor Operated Swinging Lance Sprayer by Using ASPEE-SPGF Spray Guns. *Current Journal of Applied Science and Technology*. 2020;39(48): 495–502.