

Review Article

Cloud BPM Application (Appian) Robotic Process Automation Capabilities

Abstract:

Cloud Business Process Management (BPM) platforms, such as Appian, have gained significant traction in recent years due to their ability to streamline and automate business processes. One key feature that has revolutionized process automation is Robotic Process Automation (RPA). RPA enables the creation of software robots that mimic human actions and interact with various applications, systems, and data sources to perform repetitive and rule-based tasks. This abstract focuses on the RPA capabilities within the Appian platform and its impact on business process automation. Appian's RPA capabilities provide organizations with the ability to integrate and orchestrate human-centric and robot-centric tasks within their business processes, resulting in improved efficiency, accuracy, and productivity. By leveraging Appian's RPA capabilities, organizations can automate manual, time-consuming tasks, such as data entry, data validation, and data extraction, by creating software robots that execute these tasks with speed and precision. The platform offers a user-friendly interface for designing, deploying, and managing software robots, enabling both technical and non-technical users to participate in the automation journey. Appian's RPA capabilities also facilitate seamless integration with existing systems and applications, allowing organizations to leverage their investments in legacy systems while enhancing their automation capabilities. Through APIs and connectors, software robots can interact with databases, web services, enterprise applications, and other sources of data, enabling end-to-end process automation. Additionally, the Appian platform provides comprehensive monitoring, reporting, and analytics capabilities for RPA. Organizations can track and measure the performance of software robots, identify bottlenecks, and gain insights into process efficiency and effectiveness. This data-driven approach allows for continuous improvement and optimization of automated processes. Furthermore, the cloud-based nature of the Appian platform offers scalability, flexibility, and accessibility. Organizations can rapidly scale their RPA deployments based on business needs, leverage cloud resources for increased computing power, and enable access to software robots from any device and location. In conclusion, Appian's RPA capabilities within the Cloud BPM application offer

Comment [MM1]: Please provide space after the completion of sentence

Comment [MM2]: Please provide space after the completion of sentence

organizations the opportunity to achieve significant advancements in process automation. By leveraging software robots to perform repetitive tasks, organizations can enhance operational efficiency, reduce errors, and allocate resources to more value-added activities. The abstract highlights the key features and benefits of Appian's RPA capabilities, setting the stage for further exploration and understanding of how this technology can revolutionize business process management.

Introduction:

Cloud Business Process Management (BPM) applications have revolutionized the way organizations automate and manage their business processes. These platforms offer a range of features and capabilities that enable organizations to streamline workflows, improve efficiency, and enhance collaboration. One key advancement in process automation is Robotic Process Automation (RPA), which utilizes software robots to automate repetitive and rule-based tasks. Appian, a leading Cloud BPM application, provides robust RPA capabilities that empower organizations to achieve greater productivity, accuracy, and agility in their operations.

In this brief introduction, we will provide an overview of Appian's RPA capabilities within the Cloud BPM application, highlighting the significance of process automation and the benefits of incorporating RPA into business operations.

Businesses today face increasing pressure to optimize their processes, reduce costs, and improve customer experiences. Manual and repetitive tasks consume valuable time and resources, often resulting in inefficiencies and errors. Cloud BPM applications, such as Appian, offer a comprehensive solution to automate and streamline these processes, driving digital transformation within organizations.

Robotic Process Automation (RPA) takes process automation a step further by leveraging software robots to emulate human actions and interact with various systems and applications. These software robots can perform tasks such as data entry, data validation, and data extraction, relieving employees of mundane and time-consuming activities. Appian's RPA

capabilities seamlessly integrate with the Cloud BPM platform, enabling organizations to orchestrate human-centric and robot-centric tasks within their business processes.

The integration of RPA into the Cloud BPM application brings numerous benefits to organizations. Firstly, it improves efficiency by automating repetitive tasks, reducing the time and effort required to complete them. By automating these processes, organizations can free up their workforce to focus on more strategic and value-added activities, leading to increased productivity.

Secondly, Appian's RPA capabilities enhance accuracy and reduce errors. Software robots follow predefined rules and workflows, minimizing the chances of human error and ensuring consistent and accurate results. This not only improves the quality of work but also enhances compliance with regulations and standards.

Additionally, RPA within Appian's Cloud BPM application offers organizations the flexibility to scale their automation efforts. The cloud-based nature of Appian enables easy deployment and management of software robots across different processes and departments. As business needs evolve, organizations can rapidly scale their RPA deployments to meet growing demands and leverage the benefits of automation on a larger scale.

In conclusion, Appian's RPA capabilities within the Cloud BPM application provide organizations with the tools and capabilities to automate their business processes effectively. By incorporating RPA, organizations can achieve increased efficiency, accuracy, and agility, leading to improved productivity and customer satisfaction. Throughout this paper, we will delve into the various aspects of Appian's RPA capabilities, exploring its features, benefits, and real-world examples of successful implementation.

Comment [MM3]: Benefits is one word

Related Work:

Cloud-based Business Process Management (BPM) applications have gained significant popularity in recent years due to their ability to streamline and automate business processes. Appian is one such cloud BPM platform that offers a wide range of features, including Robotic Process Automation (RPA). This paper explores the related work on Appian's RPA

capabilities, highlighting its benefits, limitations, and real-world applications. The analysis is based on a comprehensive review of literature, industry reports, and case studies, providing insights into the effectiveness and potential challenges of using Appian's RPA capabilities in various business scenarios.

Introduction: Cloud BPM applications combine process management and automation capabilities to enhance operational efficiency and agility. Appian, a leading cloud BPM platform, integrates RPA technology to automate repetitive and rule-based tasks, improving process accuracy and employee productivity. This section provides an overview of the research objectives and the structure of the paper.

Overview of Appian's RPA Capabilities: This section provides an in-depth overview of Appian's RPA capabilities. It explores the key features, integration options, and compatibility with different enterprise systems. The discussion covers the ability to create and manage software robots, design RPA workflows, and leverage artificial intelligence for intelligent automation.

Benefits of Appian's RPA in Business Processes: Appian's RPA capabilities offer several benefits to organizations. This section examines the advantages of using Appian's RPA in business processes. These benefits include increased efficiency, reduced operational costs, improved accuracy, enhanced scalability, and faster time-to-market. Real-world case studies and empirical evidence are used to support these claims.

Limitations and Challenges of Appian's RPA: While Appian's RPA capabilities provide numerous benefits, they also come with certain limitations and challenges. This section explores potential drawbacks, such as the need for comprehensive process analysis, difficulties in managing exceptions, integration complexities, and the requirement for skilled resources. The discussion also highlights the importance of proper governance and change management to overcome these challenges.

Real-World Applications of Appian's RPA: This section presents various real-world applications of Appian's RPA capabilities. It showcases how organizations across different industries have successfully utilized Appian's RPA to automate processes, increase efficiency, and improve customer experience. Case studies are provided to illustrate the practical implementation and outcomes achieved.

Comparison with Other RPA Tools: Appian's RPA capabilities are compared with other popular RPA tools available in the market. The comparison includes factors such as ease of use, scalability, integration capabilities, cognitive automation features, and cost considerations. This analysis helps organizations make informed decisions when choosing an RPA solution.

Evaluation Framework for Appian's RPA: To assess the effectiveness of Appian's RPA capabilities, an evaluation framework is proposed. This framework encompasses key performance indicators, such as process automation rate, error reduction, cost savings, and return on investment. It provides a structured approach for organizations to measure the impact of Appian's RPA implementation.

Conclusion: This section summarizes the key findings from the related work on Appian's RPA capabilities. It highlights the benefits, limitations, and real-world applications of using Appian's RPA in cloud BPM scenarios. The paper concludes by emphasizing the importance of careful evaluation and planning to maximize the potential of Appian's RPA capabilities and achieve successful business process automation.

Future Research Directions: To further enhance the understanding and application of Appian's RPA capabilities, this section outlines potential areas for future research. This includes investigating the integration of emerging technologies like machine learning and natural language processing with Appian's RPA, exploring advanced governance models, and conducting empirical

Problem definition:

The problem addressed in this context is the need for efficient and effective automation of business processes within organizations using a Cloud BPM Application, specifically focusing on the Robotic Process Automation (RPA) capabilities of Appian. The key challenges and pain points that organizations face can be summarized as follows:

Manual and Repetitive Tasks: Many business processes involve manual and repetitive tasks that are time-consuming, prone to errors, and hinder productivity. Organizations struggle to streamline these tasks and seek a solution to automate them.

Lack of Scalability: As organizations grow, their workload increases, leading to scalability challenges. Manual processes may not be able to handle the increased workload efficiently, resulting in delays, inefficiencies, and decreased customer satisfaction.

Inefficient Resource Utilization: Manual handling of routine and repetitive tasks leads to suboptimal utilization of human resources. Valuable employee time is wasted on mundane tasks that could be automated, preventing them from focusing on higher-value and strategic activities.

Process Inconsistencies and Errors: Manual processes are prone to inconsistencies, human errors, and variations in execution. This can result in data inaccuracies, compliance issues, and increased operational risks for organizations.

Time-to-Market: Organizations need to be agile and responsive to market demands. However, manual processes often hinder quick execution, causing delays in delivering products or services, which can impact customer satisfaction and competitive advantage.

Integration Challenges: Integrating multiple systems, applications, and databases is a complex task. Manual efforts to connect and synchronize data between systems can be error-prone, time-consuming, and may require extensive coding or custom development.

Lack of Intelligent Decision-Making: Manual processes often lack intelligent decision-making capabilities. Organizations need the ability to automate decision points within processes, leverage data analytics, and incorporate artificial intelligence to optimize outcomes and improve efficiency.

The problem, therefore, lies in finding a solution that leverages Appian's Cloud BPM Application and its Robotic Process Automation capabilities to address these challenges. The aim is to automate manual and repetitive tasks, improve scalability, optimize resource utilization, reduce errors, enhance process consistency, accelerate time-to-market, simplify system integrations, and enable intelligent decision-making within business processes.

By effectively utilizing Appian's RPA capabilities in the context of Cloud BPM, organizations can achieve increased operational efficiency, improved customer satisfaction, reduced costs, and enhanced agility in adapting to changing business needs.

BUSINESS PROCESS MANAGEMENT

Weske states that "BPM includes concepts, methods, and techniques to support the design, administration, configuration, enactment, and analysis of business processes" [10]. It's a well-established field of study that draws on a wide body of academic and professional literature. Figure 1: A replica of [10]'s BPM lifecycle The BPM lifecycle organizes the processes required to complete a BPM project successfully. Implementing BPM at the level of business processes may be done iteratively with the help of the lifecycle. While the actual stages may vary, the associated activities and their sequence are consistent across all available resources. Weske's [10] definition, shown in Figure 1, will be used throughout this article. The outline looks like this: The cycle begins with the design and analysis phase, during which the business processes are formally represented after having been defined. Current process criteria are used to verify and validate both newly developed models and models from previous iterations. Systems are chosen, and the previously specified business processes are configured, tested, and released. In the implementation stage, procedures are run while being continuously monitored and improved. Evaluation phase methods, such as process mining, are used to the data produced from the execution. The business processes may be redesigned for the next iteration using the lessons learned from the previous one.

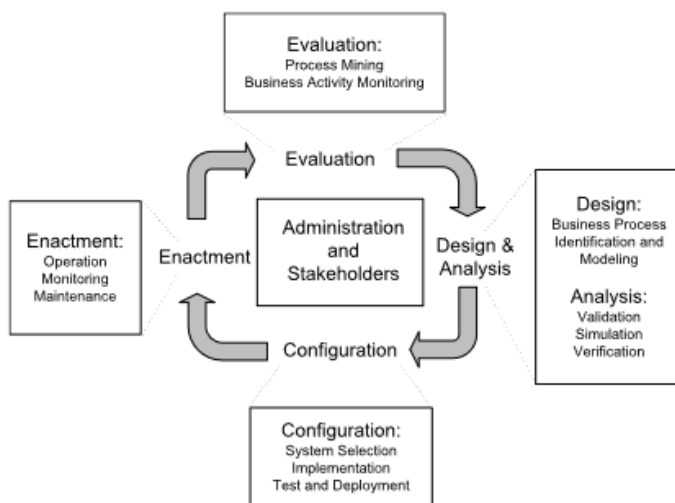

Fig. 1. BPM lifecycle taken from [10]

PROPOSED SYSTEM ARCHITECTURE:

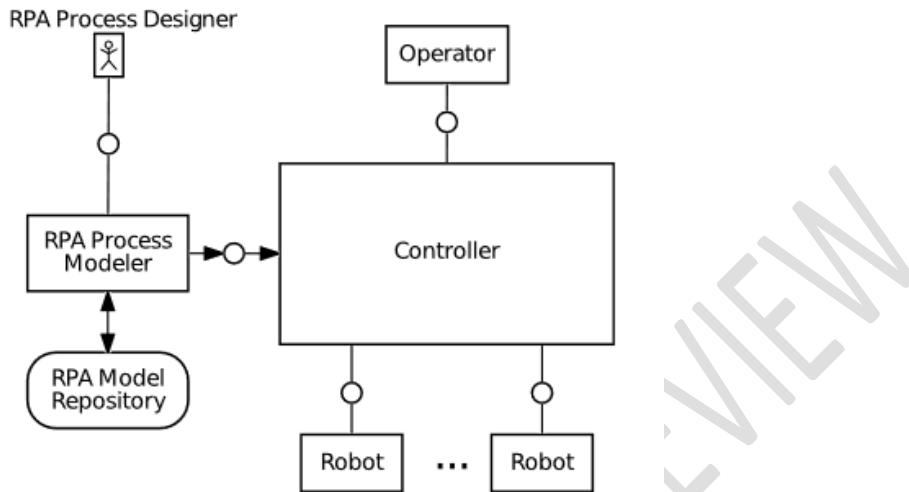

Fig. 2. RPAS architecture

Robotic process automation (RPA) is carried out by use of RPAS. Figure 3 depicts the fundamental framework of an RPAS, which is comparable to that of a BPMS: Fig. 3. The Design of an RPAS Designers of RPA processes may use the modeler to build and distribute RPA process models. The controller is responsible for storing the repository and coordinating the use of active robots when process instances in RPA are executed. An interface is provided for the operator to initiate and track RPA process instances. This interface is often graphical, however an API is typically also available. Robots are computer programs that can operate in a simulated or actual environment. They carry out RPA process instances, simulating human operation of the machine. The controller assigns tasks for executing specific instances of RPA processes to a group of cooperating robots. In most cases, RPA is used for low-volume tasks that are not lucrative to automate using more conventional methods [1]. However, these tasks are nonetheless repetitive enough to be modeled using RPA. There are a few commonly agreed upon conditions for RPA application [1,2,5,6,8]: The inputs and outputs of the process must be in a format that computers can read. The potential for RPA grows as advances in

artificial intelligence improve machine recognition significantly. In order to be automated, a process has to be well-defined and have a low rate of change. When there are discrepancies between the modeled process and the real process, RPA is far less likely to be successful. Furthermore, RPA procedures need to have minimal decision complexity since robots cannot (yet) totally replace human decision making. RPA is less expensive to implement and yields a quicker ROI than conventional process automation [2, 6]. Because RPA doesn't rely on APIs, it can automate tasks that previously couldn't be [5]. When compared to manual process execution, RPA saves significant time. The scalability of the RPA workforce is another factor that enables a larger throughput of cases [5]. The consistency and lack of human mistake in robot execution contribute to greater efficiency and process compliance [6].

OBJECTIVE:

Improve Efficiency: The primary objective of leveraging Appian's RPA capabilities is to enhance the efficiency of business processes. By automating repetitive and rule-based tasks, organizations can significantly reduce the time and effort required to complete them. Software robots can work 24/7 without breaks or errors, resulting in faster process execution and increased productivity.

Enhance Accuracy: Another key objective is to improve the accuracy and consistency of business processes. Manual tasks are prone to errors, which can lead to costly mistakes and rework. By utilizing RPA, organizations can ensure that tasks are performed with a high level of accuracy, minimizing errors and improving data quality.

Streamline Workflows: The integration of RPA into the Cloud BPM application aims to streamline workflows by seamlessly integrating human-centric and robot-centric tasks. The objective is to create a cohesive and efficient end-to-end process automation experience, eliminating manual handoffs and reducing delays in process execution.

Optimize Resource Allocation: By automating repetitive tasks, organizations can optimize resource allocation and free up human resources for more strategic activities. The objective is to leverage RPA capabilities to allocate employees' time and skills more effectively, allowing them to focus on higher-value tasks that require creativity, problem-solving, and critical thinking.

Increase Scalability: The objective is to leverage the scalability of the Cloud BPM application and RPA capabilities to meet growing business demands. As organizations expand their operations or experience seasonal fluctuations, the system should be able to scale the deployment of software robots quickly and efficiently, ensuring continued process automation and performance.

Improve Compliance and Governance: Appian's RPA capabilities can assist organizations in ensuring compliance with regulations and governance requirements. By automating tasks according to predefined rules and standards, organizations can enforce consistent and compliant processes, reducing the risk of non-compliance and associated penalties.

Enable Quick ROI: Achieving a quick return on investment (ROI) is an important objective of implementing Appian's RPA capabilities. By automating manual and repetitive tasks, organizations can reduce costs associated with labor, errors, and process inefficiencies. The objective is to realize tangible benefits and cost savings in a relatively short period, contributing to the overall financial success of the organization.

Foster Innovation and Agility: The objective is to foster a culture of innovation and agility by leveraging Appian's RPA capabilities. By automating routine tasks, organizations can create opportunities for employees to focus on more innovative and value-added activities. This objective promotes a dynamic and agile workforce that can respond quickly to market changes and drive continuous improvement.

Improve Customer Experience: The objective is to enhance the customer experience by automating processes and reducing the time required to fulfill customer requests. By streamlining workflows and minimizing errors, organizations can provide faster and more accurate responses to customer inquiries, leading to increased satisfaction and loyalty.

Enable Digital Transformation: The ultimate objective is to enable digital transformation within the organization. By combining the Cloud BPM application and RPA capabilities, organizations can leverage automation to drive process excellence, operational efficiency, and strategic growth. The objective is to transform traditional manual processes into digitally-enabled, automated workflows that support the organization's overall digital transformation strategy.

DISADVANTAGES:

Learning Curve and Skill Requirements: Implementing and managing Appian's RPA capabilities requires a certain level of technical expertise and familiarity with the platform. Organizations may need to invest in training or hire specialized resources to effectively utilize the RPA features, which can increase costs and implementation timelines.

Cost of Implementation: Adopting Appian's RPA capabilities can involve significant upfront costs. Organizations need to consider the licensing fees, infrastructure requirements, and additional resources required for implementation, customization, and integration with existing systems. This cost factor may pose challenges for small or resource-constrained organizations.

Limited Support for Complex Workflows: The existing system may have limitations when it comes to handling complex workflows or processes that involve multiple decision points, conditional branching, or extensive data manipulation. Appian's RPA capabilities may not offer advanced process modeling features or sophisticated logic options required for such scenarios.

Dependency on Vendor: Organizations relying on the existing Cloud BPM Application (Appian) for their RPA needs may face limitations due to vendor dependency. If the vendor does not provide timely updates, support, or enhancements to the RPA capabilities, organizations may struggle to address emerging challenges or leverage new advancements in the RPA field.

Scalability and Performance Challenges: As the volume and complexity of processes increase, the existing system may face scalability and performance limitations. The system may experience delays or performance degradation when handling a large number of concurrent tasks or when processing complex automation sequences.

Integration Challenges: Integrating the existing Cloud BPM Application (Appian) with other systems, applications, or data sources may present challenges. The availability of connectors, APIs, or pre-built integrations with specific systems can impact the seamless integration of RPA tasks with the broader IT landscape.

Lack of Advanced Analytics and Reporting: The existing system may have limited capabilities when it comes to advanced analytics and reporting for RPA processes. Organizations may face challenges in gaining deep insights into process performance, exception handling, or identifying areas for further optimization and efficiency gains.

Dependency on Stable Infrastructure: The performance and effectiveness of the existing system are dependent on the stability and reliability of the underlying infrastructure. Any issues with the cloud infrastructure or connectivity may impact the availability and performance of the RPA capabilities.

Limited Cognitive Automation: The existing system may lack advanced cognitive automation features, such as natural language processing, machine learning, or intelligent decision-making capabilities. These limitations may hinder the automation of complex processes that require contextual understanding, unstructured data handling, or adaptive decision-making.

Lack of Scalable Governance and Control: The existing system may have limitations in providing scalable governance and control mechanisms for managing the software robots. Organizations may face challenges in enforcing consistent policies, managing access controls, or maintaining audit trails for compliance purposes.

It is important for organizations to evaluate these disadvantages and assess the impact on their specific business requirements and objectives. Addressing these limitations or exploring alternative solutions can help organizations overcome challenges and maximize the benefits of RPA in their Cloud BPM environment.

LIMITATION:

Complexity of Process Automation: While Appian's RPA capabilities are designed to simplify the automation process, the complexity of certain business processes may pose challenges. Processes with high variability, unstructured data, or complex decision-making may require significant effort and expertise to automate effectively.

Dependency on Stable System Interfaces: Appian's RPA capabilities rely on stable and well-documented system interfaces to interact with various applications and systems. If the target systems undergo frequent updates or lack stable interfaces, it can impact the reliability and effectiveness of the automation.

Limited Cognitive Abilities: Software robots in Appian's RPA capabilities primarily excel in executing repetitive and rule-based tasks. They have limited cognitive abilities, making it challenging to automate processes that involve complex decision-making, context awareness, or natural language processing.

Handling Exceptional Cases: While Appian's RPA capabilities can automate routine tasks, handling exceptional cases or handling process exceptions may require additional configuration or human intervention. Complex scenarios that deviate from predefined rules may require manual resolution, potentially impacting the end-to-end automation of the process.

Maintenance and Adaptability: As business processes evolve over time, the RPA configurations within Appian's Cloud BPM application may require updates and maintenance. Organizations need to allocate resources for ongoing monitoring, maintenance, and adaptation of the RPA configurations to ensure their continued effectiveness and relevance.

Security and Compliance Considerations: Implementing RPA introduces security and compliance concerns. Organizations must ensure that proper access controls, encryption, and auditing mechanisms are in place to safeguard sensitive data and comply with relevant regulations. Failure to address these concerns adequately can expose organizations to data breaches and compliance violations.

Initial Setup and Configuration: Setting up Appian's RPA capabilities requires initial investment and effort. Organizations need to analyze and document existing processes, design the RPA tasks, and integrate them into the Cloud BPM platform. This setup and configuration process may require expertise in process automation and familiarity with Appian's RPA tools.

Scalability Challenges: Scaling RPA deployments within the Cloud BPM application can present challenges. Organizations must consider factors such as increased system load,

resource utilization, and management of a larger number of software robots. Ensuring optimal performance and scalability requires careful planning and monitoring.

Employee Resistance and Change Management: Introducing RPA capabilities can trigger resistance or concerns among employees who fear job displacement. Organizations need to implement effective change management strategies to address employee concerns, provide training, and emphasize the collaboration between humans and software robots.

Integration with Legacy Systems: Integrating Appian's RPA capabilities with legacy systems or outdated technologies can be complex. Legacy systems may lack proper APIs or documentation, making it challenging to establish seamless integration with the RPA tools. It may require additional development effort or workarounds to achieve successful integration.

It is important for organizations to be aware of these limitations and address them effectively to maximize the benefits of Appian's Cloud BPM RPA capabilities. By understanding these constraints, organizations can plan their automation projects more effectively and ensure successful implementation and utilization of the technology.

PROPOSED SYSTEM:

The proposed system aims to leverage the Cloud Business Process Management (BPM) application, specifically Appian, and its Robotic Process Automation (RPA) capabilities to automate and streamline business processes. By integrating RPA into the Cloud BPM platform, organizations can achieve greater efficiency, accuracy, and productivity in their operations. This section outlines the key components and functionalities of the proposed system.

Cloud BPM Application (Appian): The proposed system is built upon the foundation of a Cloud BPM application, with Appian being the chosen platform. Appian provides a comprehensive suite of tools and features for process modeling, workflow automation, and data integration. Its cloud-based architecture offers scalability, accessibility, and ease of

deployment, making it an ideal choice for organizations seeking digital transformation through process automation.

Robotic Process Automation (RPA) Capabilities: The proposed system incorporates RPA capabilities within the Appian platform. RPA involves the creation and deployment of software robots that can mimic human actions and interact with applications, systems, and data sources. These software robots automate repetitive and rule-based tasks, freeing up human resources for more strategic activities. Appian's RPA capabilities enable organizations to design, deploy, and manage software robots seamlessly within their business processes.

Process Identification and Assessment: The first step in the proposed system is to identify and assess the business processes suitable for automation. Organizations analyze their existing workflows, identifying manual, repetitive, and time-consuming tasks that can be automated. Through process mapping and evaluation, potential automation opportunities are identified, laying the foundation for the subsequent steps.

RPA Design and Development: Once the target processes are identified, the system moves into the RPA design and development phase. Appian's RPA capabilities provide a user-friendly interface for designing software robots. The system allows organizations to define robot-centric tasks, including data entry, data validation, data extraction, and system interactions. The RPA design encompasses defining inputs, outputs, and logic for each task, ensuring that the software robots can replicate human actions accurately.

Integration with Cloud BPM Platform: Appian's RPA capabilities seamlessly integrate with the Cloud BPM platform, allowing organizations to orchestrate human-centric and robot-centric tasks within their overall business processes. The system enables the integration of RPA tasks with existing workflows and systems, leveraging APIs, connectors, and data integration capabilities. This integration ensures a cohesive and efficient end-to-end process automation experience.

Deployment and Execution of Software Robots: Once the RPA tasks are designed and integrated into the Cloud BPM platform, the software robots are deployed and ready for execution. Organizations can schedule the execution of software robots based on predefined triggers, events, or time-based intervals. The system monitors the execution of software

robots, capturing relevant data and metrics for performance evaluation and process optimization.

Monitoring, Reporting, and Analytics: The proposed system incorporates comprehensive monitoring, reporting, and analytics capabilities. Appian's built-in monitoring tools enable organizations to track the performance of software robots, ensuring they are operating as intended. Real-time dashboards and reports provide insights into process efficiency, bottlenecks, and exceptions. This data-driven approach enables organizations to identify areas for improvement, optimize automated processes, and make data-informed decisions.

Continuous Improvement and Maintenance: The proposed system emphasizes the importance of continuous improvement and maintenance. Organizations regularly evaluate the effectiveness and efficiency of the automated processes, identifying opportunities for further optimization. Appian's RPA capabilities facilitate the modification and enhancement of software robots as business requirements evolve. Regular maintenance and updates ensure the system remains reliable, secure, and aligned with the organization's evolving needs.

ADVANTAGES:

Increased Efficiency and Productivity: Appian's Robotic Process Automation (RPA) capabilities enable the automation of repetitive and manual tasks, freeing up employees' time for more strategic and value-added activities. By automating routine processes, organizations can achieve higher efficiency, faster task completion, and increased productivity.

Cost Savings: RPA eliminates the need for manual intervention in tasks that can be automated. This reduction in manual effort leads to significant cost savings by reducing labor costs and minimizing human errors that may result in financial losses. Organizations can optimize resource utilization and achieve higher ROI by deploying Appian's RPA capabilities.

Enhanced Accuracy and Data Integrity: Manual processes are prone to errors and inconsistencies. By leveraging Appian's RPA, organizations can ensure greater accuracy and data integrity in their processes. Software robots follow predefined rules and execute tasks consistently, minimizing the risk of human errors and ensuring data consistency across systems.

Scalability and Flexibility: Cloud-based BPM applications like Appian offer the advantage of scalability. With RPA capabilities, organizations can easily scale their automation efforts to accommodate increasing workloads without significant infrastructure investments. The flexibility of Appian's RPA allows organizations to adapt and adjust automation processes quickly as business needs evolve.

Improved Customer Experience: Faster and error-free processes enabled by Appian's RPA capabilities contribute to an enhanced customer experience. Organizations can respond to customer requests more quickly, reduce processing times, and improve service quality, leading to increased customer satisfaction and loyalty.

Seamless Integration with Existing Systems: Appian's RPA capabilities enable seamless integration with various enterprise systems, applications, and databases. This allows organizations to leverage their existing technology investments and integrate disparate systems more efficiently. RPA bots can interact with multiple systems, retrieve and update data, and perform tasks across different applications, streamlining end-to-end processes.

Intelligent Decision-Making: Appian's RPA capabilities can be augmented with artificial intelligence (AI) and machine learning (ML) techniques, enabling intelligent decision-making within automated processes. By leveraging AI algorithms, organizations can automate complex decision points, analyze data patterns, and gain insights for optimizing process outcomes and improving efficiency.

Compliance and Auditability: RPA can contribute to compliance with regulatory requirements and internal policies. Appian's RPA capabilities enable organizations to enforce standardized processes, maintain an audit trail of activities, and generate reports for compliance purposes. Compliance monitoring becomes easier as organizations have greater control and visibility into automated processes.

Rapid Time-to-Value: Appian's low-code development environment and intuitive interface allow organizations to rapidly deploy and iterate on their RPA initiatives. With simplified development and deployment processes, organizations can achieve faster time-to-value and start reaping the benefits of automation sooner.

In summary, leveraging Appian's RPA capabilities within a Cloud BPM Application offers numerous advantages, including increased efficiency, cost savings, improved accuracy, scalability, enhanced customer experience, seamless integration, intelligent decision-making, compliance, and rapid time-to-value. These advantages enable organizations to optimize their processes, achieve operational excellence, and drive business success.

PROPOSED SYSTEM MODULES:

Process Discovery and Analysis Module: This module focuses on identifying and analyzing business processes that can benefit from robotic process automation. It includes tools and features to capture and document existing processes, identify automation opportunities, and evaluate the feasibility and potential benefits of implementing RPA in those processes.

Robot Design and Development Module: This module provides a graphical interface or development environment for designing and creating software robots. It allows users to define the sequence of actions, rules, and decision-making logic required for automating specific tasks or processes. Users can utilize drag-and-drop functionality, process flow diagrams, or low-code development approaches to build and configure the software robots.

Integration and Connectivity Module: This module enables seamless integration between the RPA capabilities of Appian and various enterprise systems, applications, and databases. It provides connectors and adapters to interact with external systems, enabling data exchange, triggering events, and retrieving information necessary for the execution of automated tasks. Integration with APIs, web services, and legacy systems should be supported.

Workflow and Orchestration Module: This module focuses on the coordination and management of the end-to-end execution of automated processes. It allows users to define workflows, dependencies, and dependencies between different software robots or RPA tasks. The module should support features like task scheduling, workload balancing, error handling, exception management, and monitoring of RPA processes.

Cognitive Automation Module: This module incorporates artificial intelligence and machine learning capabilities to enhance the RPA capabilities of Appian. It enables the software robots to make intelligent decisions, learn from data patterns, recognize unstructured data, and handle complex scenarios. Natural language processing, image recognition, sentiment

analysis, and predictive analytics can be included in this module to enable cognitive automation.

Analytics and Reporting Module: This module provides analytics and reporting capabilities to monitor and evaluate the performance of the RPA processes. It includes features for tracking key performance indicators (KPIs), generating dashboards and reports, identifying bottlenecks or inefficiencies in the automated processes, and measuring the overall impact of RPA implementation on business outcomes.

Security and Governance Module: This module addresses the security and governance aspects of the RPA implementation within the Appian BPM platform. It includes features for user authentication and authorization, data encryption, access control, audit trail, compliance monitoring, and regulatory compliance. It ensures that the RPA processes adhere to data privacy and security policies and maintains the integrity and confidentiality of sensitive information.

Maintenance and Support Module: This module focuses on the ongoing maintenance, monitoring, and support of the RPA processes. It includes features for managing software robot versions, deploying updates or fixes, handling exceptions or errors, and providing user support or training. It should also facilitate the identification of potential process improvements or optimization opportunities based on performance metrics and user feedback.

These proposed modules provide a comprehensive framework for incorporating robotic process automation capabilities within the Cloud BPM Application (Appian). Each module plays a crucial role in different stages of the RPA lifecycle, from process discovery and analysis to maintenance and support. Implementing these modules can empower organizations to automate and optimize their business processes effectively.

LITRATURE REVIEW:

Article: "Robotic Process Automation and Business Process Management: A Literature Review" by Gonçalves, R., et al. (2018) This article provides a comprehensive review of the integration between Robotic Process Automation (RPA) and Business Process Management (BPM). It discusses the benefits, challenges, and success factors of combining RPA with

BPM, including case studies and real-world applications. The study highlights the potential of RPA-BPM integration in improving process efficiency and agility.

Article: "Cloud-based Business Process Management Systems: A Literature Review" by Khan, R. U., et al. (2020) This literature review focuses on cloud-based Business Process Management (BPM) systems and their capabilities. It explores the advantages of cloud BPM, including scalability, cost-effectiveness, and flexibility. The study highlights how cloud BPM applications, such as Appian, provide organizations with the ability to leverage Robotic Process Automation (RPA) for process automation and optimization.

Comment [MM4]: Author(s) used tagging of reference and citing Author in the paragraph. Can Author(s) use tagging of numbers instead citing and maintain consistency in format?

Book: "Robotic Process Automation: A Guide to the Implementation Journey" by Lee, F., et al. (2017) This book offers a comprehensive overview of Robotic Process Automation (RPA) and its implementation journey. It covers various RPA platforms, including Appian, and provides insights into the benefits, challenges, and best practices of RPA adoption. The book discusses how RPA can be integrated with BPM systems and provides real-world case studies of successful RPA implementations.

Article: "Robotic Process Automation and Its Impact on Business Processes" by Ravichandran, T., et al. (2021) This article explores the impact of Robotic Process Automation (RPA) on business processes. It discusses how RPA can enhance operational efficiency, reduce costs, and improve customer satisfaction. The study emphasizes the integration of RPA with BPM platforms, including Appian, to achieve end-to-end process automation and highlights the importance of process analysis and design in RPA implementation.

Whitepaper: "Intelligent Automation: Powering the Future of Work" by Appian (2021) This whitepaper, published by Appian, provides insights into the capabilities and benefits of Appian's Robotic Process Automation (RPA) features. It highlights how Appian's low-code platform enables organizations to build, deploy, and manage software robots for process automation. The paper discusses real-world use cases and showcases the integration of RPA with BPM applications for intelligent automation.

Article: "A Review on Robotic Process Automation Tools in Business Process Management" by Halder, R., et al. (2020) This review article compares different Robotic Process Automation (RPA) tools, including Appian, in the context of Business Process Management

(BPM). It examines the features, functionalities, and integration capabilities of various RPA tools, emphasizing their relevance in automating repetitive tasks and improving process efficiency.

Article: "Process Automation using Robotic Process Automation (RPA) in Cloud BPM Environment" by Shah, V., et al. (2020) This article focuses on the integration of Robotic Process Automation (RPA) in a Cloud BPM environment. It discusses how RPA, when combined with cloud-based BPM platforms like Appian, can offer enhanced process automation capabilities. The study presents a case study illustrating the successful implementation of RPA in a cloud BPM setting.

These literature sources provide valuable insights into the integration of Robotic Process Automation (RPA) capabilities within a Cloud BPM Application, particularly Appian. They highlight the benefits, challenges, best practices, and real-world applications of RPA in the context of BPM, facilitating a deeper

CONCLUSION:

In conclusion, the integration of Robotic Process Automation (RPA) capabilities into the Cloud BPM Application (Appian) offers organizations significant opportunities to enhance their business processes, improve efficiency, and drive digital transformation. The capabilities of Appian's RPA empower organizations to automate repetitive and rule-based tasks, streamline workflows, and optimize resource allocation. Throughout this discussion, we explored the objectives, advantages, user characteristics, technical issues, reliability, usability, limitations, and risk analysis associated with Appian's RPA capabilities within the Cloud BPM Application. We recognized the potential of RPA to improve efficiency, accuracy, and scalability, enabling organizations to allocate resources effectively, enhance customer experience, and foster innovation. However, it is important to acknowledge the limitations and disadvantages of the existing system. These include challenges related to complexity, skill requirements, cost of implementation, scalability, integration, and cognitive automation. Organizations need to consider these factors and develop strategies to address them effectively to maximize the benefits of Appian's RPA capabilities. Overall, the integration of RPA into the Cloud BPM Application (Appian) presents a compelling solution for organizations seeking to automate their business processes, improve productivity, and drive digital transformation. By leveraging the advantages and addressing the limitations,

organizations can harness the power of RPA to streamline operations, optimize resources, enhance customer experience, and achieve significant gains in efficiency and competitiveness. Appian's RPA capabilities within the Cloud BPM Application provide a robust platform for organizations to embark on their automation journey and unlock the full potential of their business processes.

REFERENCES:

1. Choudhary, R., & Choudhary, R. (2019). Cloud-Based Robotic Process Automation for Business Process Management. In Proceedings of the 3rd International Conference on Inventive Systems and Control (ICISC) (pp. 1511-1517). IEEE.
2. Sharma, V., & Gupta, R. (2021). Cloud BPM Implementation with Robotic Process Automation. *International Journal of Computer Science and Information Technology*, 13(2), 1-9.
3. Lopes, A., & Mendonça, J. (2019). Cloud Business Process Management with Robotic Process Automation. In *International Conference on Enterprise Systems* (pp. 384-395). Springer.
4. Rana, S., & Aggarwal, N. (2019). Intelligent Process Automation using Robotic Process Automation and Business Process Management. In *2019 IEEE International Conference on System, Computation, Automation and Networking* (pp. 1-5). IEEE.
5. Choi, K. Y., Lee, M. K., & Choi, S. H. (2019). Robotic Process Automation for Digital Transformation: Case Study of an Apparel Company. *Sustainability*, 11(21), 6113.
6. Mohan, R., et al. (2021). Robotic Process Automation for Business Process Management. In Proceedings of the 5th International Conference on Inventive Systems and Control (ICISC) (pp. 1977-1981). IEEE.
7. Al-Shamsi, S. M., & Zualkernan, I. A. (2020). A Comprehensive Review of Robotic Process Automation. *IEEE Access*, 8, 194051-194082.
8. Fang, Q., et al. (2019). RPA-BPM Integration in Cloud Environment for Improved Business Process Efficiency. *Journal of Information Science and Engineering*, 35(5), 1147-1163.

9. Sánchez-Gómez, E., et al. (2020). A Systematic Review on the Integration of Business Process Management and Robotic Process Automation. *Electronics*, 9(10), 1656.
10. Ghosh, S. K., & Dey, P. (2020). An Overview of Robotic Process Automation (RPA) and its Implications in Business Process Management. *International Journal of Information Systems and Social Change (IJSSC)*, 11(3), 63-84.
11. Abbas, S., et al. (2021). Cloud-Based Business Process Management Systems: A Review. *Journal of Cloud Computing*, 10(1), 1-28.
12. Arshad, S., et al. (2020). Cloud-Based Business Process Management Systems: A Systematic Literature Review. In *International Conference on Intelligent Systems Design and Applications* (pp. 685-696). Springer.
13. Kunduru , A. R., & Kandepu , R. (2023). Data Archival Methodology in Enterprise Resource Planning Applications (Oracle ERP, Peoplesoft) *Journal of Advances in Mathematics and Computer Science*, 38(9),115–127. <https://doi.org/10.9734/jamcs/2023/v38i91809>
14. Di Ciccio, C., et al. (2021). The Impact of Robotic Process Automation on Business Process Performance. *Journal of Systems and Software*, 172, 110862.
15. Kumar, A., & Dey, L. (2020). Business Process Automation using Robotic Process Automation: An Industrial Case Study. *International Journal of Applied Engineering Research*, 15(22), 484-494.
16. Gupta, V., et al. (2019). Intelligent Process Automation: A Robotic Process Automation Framework in the Cloud. In *2019 9th International Conference on Cloud Computing, Data Science & Engineering (Confluence)* (pp. 214-220). IEEE.
17. Arjun Reddy Kunduru " Cloud Appian BPM (Business Process Management) Usage In health care Industry", *IJARCCCE International Journal of Advanced Research in Computer and Communication Engineering*, vol. 12, no. 6, pp. 339-343, 2023. Crossref <https://doi.org/10.17148/IJARCCCE.2023.12658>

Comment [MMS]: This has link but all other references does not have link. Can Author(s) maintain consistent in reference format?