

Original Research Article

Design and Fabrication of Vapour Compression Refrigeration Cycle Based On Storage Type Domestic Water Heater

Comment [U1]: The grammar used throughout is below average. Proof reading by an expert is highly recommended

Abstract

In present scenario, generally VCR (Vapour Compression Refrigeration) cycle is used for heating and cooling. The adverse effect of release of refrigerant like global warming and ozone depletion in the atmosphere is known to all. Electric heaters use electricity which is obtained from thermal power plant run on fossil fuels. The aim of the project is to demonstrate the economic benefit of using heat rejected in the condenser of Vapour Compression Refrigeration (VCR) system and to check the feasibility of the apparatus for mass production. The main aim of the project is to develop economically viable VCR cycle based domestic water heater (Heat pump) which has a good payback period and low energy consumption compare to electric-resistance heater. To develop storage type water heater, helical coil shaped condenser brazed inside the water storage tank has been designed. Since the capacity of the VCR system is less, capillary tube has been used as an expansion device. The VCR cycle based DWH has been tested extensively and heating capacity of about 725 W has been obtained. This may be due to under sizing of evaporator or condenser or may be due to larger capillary length. The VCR cycle based DWH can save up to Rs. 4770 compared to electric resistance water heater. The simple payback period for DWH is 3 year and 1 month.

Comment [U2]: Revise the abstract to show what was done, How it was done, What was found out and the implication(s) of the findings

Key words: Vapour Compression Refrigeration, water heater, heating and cooling.

Introduction

This study intends to develop an economically viable Vapour Compression Refrigeration (VCR) cycle based storage type domestic water heater (DWH) and to demonstrate the energy saving compared to resistance heating. With fast depleting fuel resources, it is necessary to explore other sources of energy. At the same time, it is also necessary to use the available energy judiciously. During the cycle, a substance called the refrigerant circulates continuously through four stages. The first stage is called Evaporation and it is here that the refrigerant cools the enclosed space by absorbing heat. Next, during the Compression stage, the pressure of the refrigerant is increased, which raises the temperature above that of the surroundings. As this hot refrigerant moves through the next stage, Condensation, the natural direction of heat flow allows the release of energy into the surrounding air. Finally, during the Expansion phase, the refrigerant temperature is lowered by throttling. This cold refrigerant then begins the Evaporation stage again, removing more heat from the enclosed space figure-1 shows the different components of the Vapour Compression Refrigeration (VCR) cycle.

Comment [U3]: The introduction is too lopsided in that it just described basically the VCR without referring to any previous work(s). This should be updated.

Only one reference was cited in your introduction. That is not appropriate

Compressor

A compressor is a mechanical device that increases the pressure of a gas by reducing its volume. An air compressor is a specific type of gas compressor. The low pressure and temperature vapour refrigerant from evaporator is drawn into the compressor through the inlet or suction valve A, where it is compressed to a high pressure and temperature. This high pressure and temperature vapour refrigerant is discharged into the condenser through the delivery or discharge valve B. The purpose of the compressor is to circulate the refrigerant in the system under pressure, this concentrates the heat it contains. At the compressor, the low pressure gas is changed to high pressure gas. Input Current: 2.2 Amps, Voltage Range: 118-260 V, Weight: 11.8 Kg, Suction ID: 8 mm, Discharge ID: 6.5 mm, Length of Compressor: 253 mm, Height of Compressor: 212 mm.

Condenser

Condensers can be made according to numerous designs, and come in many sizes ranging from rather small (hand-held) to very large (industrial-scale units used in plant processes). For example, a refrigerator uses a condenser to get rid of heat extracted from the interior of the unit to the outside air. Condensers are used in air conditioning, industrial chemical processes such as distillation, steam power plants and other heat-exchange systems. Use of cooling water or surrounding air as the coolant is common in many condensers. Makavana et al. (2022) vapour is naturally conveyed from the top of the reactor to the condenser through a 10 cm dia. x 45 cm long duct pipe, band, flange etc. The condenser is a column type cylindrical chamber having 15 cm dia. and 70 cm long vertical pipe with conical bottom and valve as shown in Figure . This pipe and bottom is further covered by another pipe having 20 cm dia. which provided 2.5 cm annular space to the pipe and bottom for water circulation.

Expansion Valve

The expansion valve removes pressure from the liquid refrigerant to allow expansion or change of state from a liquid to a vapor in the evaporator. The high-pressure liquid refrigerant entering the expansion valve is quite warm.

Evaporator

Evaporator is to absorb heat into the refrigeration system. The term evaporator explains what happens inside the coil. Refrigerant is changed from a liquid to a vapor. This is called evaporation. An evaporator consists of coils of pipe in which the liquid-vapour. Refrigerant at low pressure and temperature is evaporated and changed into vapour refrigerant at low pressure and temperature. In evaporating, the liquid vapour refrigerant absorbs its latent heat of vaporization from the medium (air, water or brine) which is to be cooled. Makavana et al. (2020) density was increased by 3.91 times and calorific value was increased by 1.19 times.



Compressor



Condenser



Expansion Valve



Evaporator

Fig1 : Components of Vapour Compression Refrigeration (VCR) cycle

Material and method

In this type of condenser design condenser is separated from the tank of water heater. So pump used to circulate tank water through the condenser or side arm heat exchanger with natural circulation. In this design, the heat pump is completely separated from the water tank but it has a drawback that it requires a water pump. Shown fig.(a) Condenser outside the water tank and (b) Condenser tube wrapped around the water tank this design has condenser tube/coil soldered or brazed to the exterior surface of a water tank of water heater. It has an advantage that there is no need of water pump because water flow due to natural flow of water. It has disadvantage that condenser and tank must be replaced as a one unit together. Shown fig.(c) Condenser inside the water tank in this design of condenser, condenser coil is immersed in to the water. There is a good heat transfer coefficient in this design. The only drawback is Water side of condenser becomes coated with sludge.

Comment [U4]: Materials and Methods
You need to expatiate on your methodology so that it can be adopted by other researchers

Comment [U5]: Fig. 2(a)

Comment [U6]: ???

Comment [U7]: Fig. 2(c)

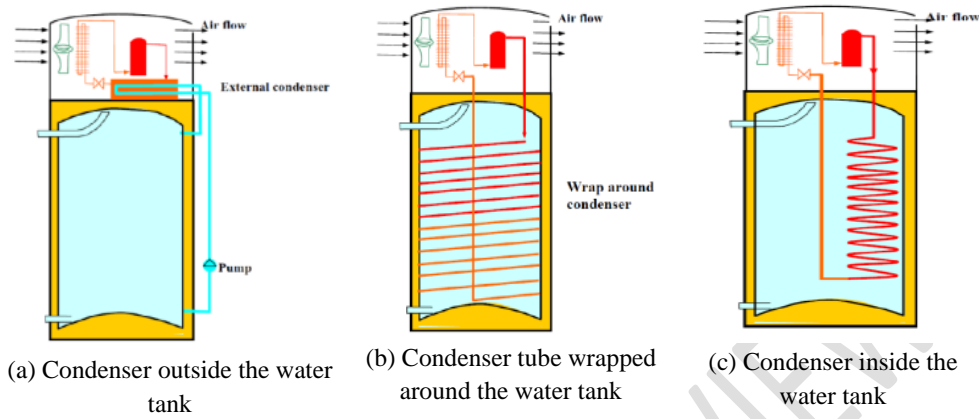

Fig 2. Drawing of Condenser's dimensions

Condenser design dimensions which are calculated given in following Table1. From Condenser's dimensions prepared drawing of it which is given in Figure 2.

Table 1: Condenser design output

Parameter	Dimension
Inner dia. Of tube	6 mm
Length	38 feet
Overall diameter of condenser	17 Cm
Number of turn	12
Pitch size between tube	2.20 Cm
Overall height of condenser	26.5 Cm

Comment [U8]: Use SI units or be consistent

Comment [U9]: cm

Effect the same adjustment for the others

The line Diagram of the front view of Domestic Water Heater Unit is given below. All the parts of this unit (DWH) are arranged so that it occupies Minimum space at installation space. To make this unit compact the evaporator is placed in helical shape around the water storage tank.

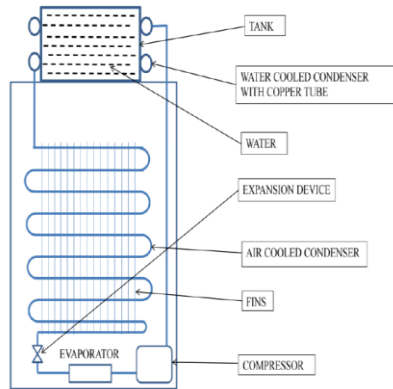

Fig 3: Line diagram of modified refrigerator



Fig 4 : Final experimental setup

Results and Discussion

Evaluate the performance improvement of Domestic Refrigerator with water cooled condenser, initially it was tested without modification. Various parameters like power consumption and temperatures at salient points were measured at regular interval. Different temperatures measured at an interval of time were compressor outlet temperature (air cooled condenser inlet temperature) (T1) freezer air temperature (T2), ambient temperature (T3). Observations of the above parameters are tabulated from Table-2 and Table-3.

Comment [U10]: State the interval of time

Comment [U11]: All of this is part of your methods and not results

Table-2: Observations of parameters of domestic refrigerator without modification and no load condition

Time duration	T1 (k)	T2 (k)	T3 (k)	$\Delta T = T2 - T1$ (k)	COP (Theoretical)
9:45 am	299	297	295	2	
10:00 am	325.4	260.5	295	64.9	2.26
10:15 am	334.6	256.3	295	78.3	1.77
10:30 am	342	255.7	295	86.3	1.35
11:00 am	347.7	255.4	295	92.3	1.25
11:30 am	352.9	254.4	295	98.5	1.21
12:00 pm	353.6	254.8	295	98.8	1.18

Table-3: Observations of parameters of domestic refrigerator without modification and with load condition

Time duration	T1 (k)	T2 (k)	T3 (k)	$\Delta T = T2 - T1$ (k)	COP (Theoretical)
4:15 pm	300	295	295	5	
4:30 pm	323.4	261.4	295	62	2.24
4:45 pm	328.6	258.8	295	69.8	2.61

5:00 pm	331.3	257.3	295	74	2.58
5:15 pm	331.7	257.1	295	74.6	2.54
5:30 pm	334.5	256.9	295	77.6	2.51
6:00 pm	335.6	256.2	295	79.4	2.47

Testing of Domestic Refrigerator with modification

To evaluate the performance improvement of Domestic Refrigerator with water cooled condenser, initially it was tested with modification. Various parameters like power consumption and temperatures at salient points were measured at regular interval. Different temperatures measured at an interval of time were compressor outlet temperature (air cooled condenser inlet temperature) (T1) freezer air temperature (T2), water tank temperature (T3). Observations of the above parameters are tabulated from Table-4 and Table-5.

Comment [U12]: Methods not Results

Table-4: Observations of parameters of domestic refrigerator with modification and no load condition

Time duration	T1 (k)	T2 (k)	T3 (k)	$\Delta T = T2 - T1$ (k)	COP (Theoretical)
2:40 pm	299.7	295.5	297.8	4.2	-
2:55 pm	327.4	254.7	303.9	72.7	2.29
3:10 pm	336.8	251.9	305.1	84.9	1.86
3:25 pm	340.5	251.5	307.5	89	1.54
3:40 pm	340.2	250.6	308.2	89.6	1.43
4:10 pm	341.1	250	310.4	91.1	1.31
4:40 pm	342.6	250.6	315.3	92.4	1.33

Table-5: Observations of parameters of domestic refrigerator with modification and with load condition

Time duration	T1 (k)	T2 (k)	T3 (k)	$\Delta T = T2 - T1$ (k)	COP (Theoretical)
10:00 am	324.6	276.9	310.4	47.7	-
10:15 am	329.7	256	310.8	73.7	1.53
10:30 am	338.2	253.1	312.1	85.1	1.51
10:45 am	340.4	252.8	313.1	87.6	1.48
11:00 am	341.5	253.4	315.1	88.1	1.45
12:00 pm	344.7	255.1	319.9	89.6	1.35
2:30 pm	357.9	262.6	331.3	93.3	1.25

Calculation of COP

The efficiency of a refrigerator or heat pump is given parameter called the coefficient of performance (COP).

COP of refrigerator is given by bellow equation

Comment [U13]: The presentations of the details of your calculations is not appropriate

You may decide to present the procedure in flowcharts or simply state the equations you used

$$COP = \frac{h_1 - h_{f3}}{h_2 - h_1}$$

Where, h_1 = Enthalpy of vapour refrigerant at temperature T_1 , (kJ/kg)

h_2 = Enthalpy of vapour refrigerant at temperature T_2 , (kJ/kg)

h_{f3} = Sensible heat at temperature T_3 , (kJ/kg)

Comment [U14]: kJ/kg

Apply wherever necessary

(1) Theoretical COP of no load condition:

Here at 3:10 am and different temperature $T_1 = 336.8$ k and $T_2 = 251.9$ k from p-h diagram, we get $h_1 = 390$ kJ/kg, $h_2 = 442$ kJ/kg and $h_{f3} = 293$ kJ/kg.

$$COP = \frac{h_1 - h_{f3}}{h_2 - h_1}$$

$$COP = \frac{390 - 293}{442 - 390}$$

$$COP = 1.86$$

(2) Theoretical COP of with load condition:

Here at 10:30am and different temperature $T_1 = 338.2$ k and $T_2 = 253.1$ k from p-h diagram, we get $h_1 = 385$ kJ/kg, $h_2 = 442$ kJ/kg and $h_{f3} = 295$ kJ/kg.

$$COP = \frac{h_1 - h_{f3}}{h_2 - h_1}$$

$$COP = \frac{385 - 295}{442 - 385}$$

$$COP = 1.51$$

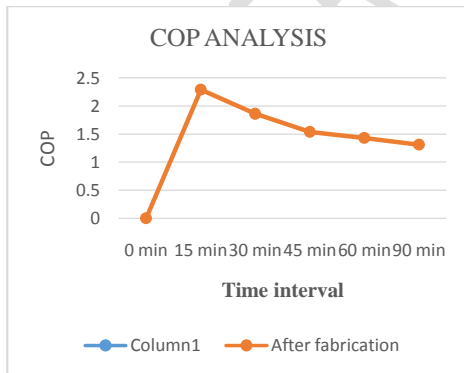

Fig 5: Time vs cop (After fabrication)

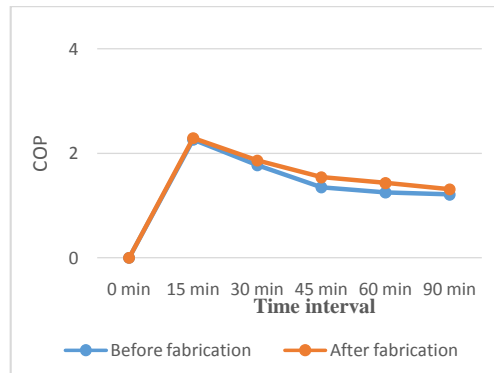

Fig 6 : Time vs. COP (comparison between data's of before fabrication and after fabrication)

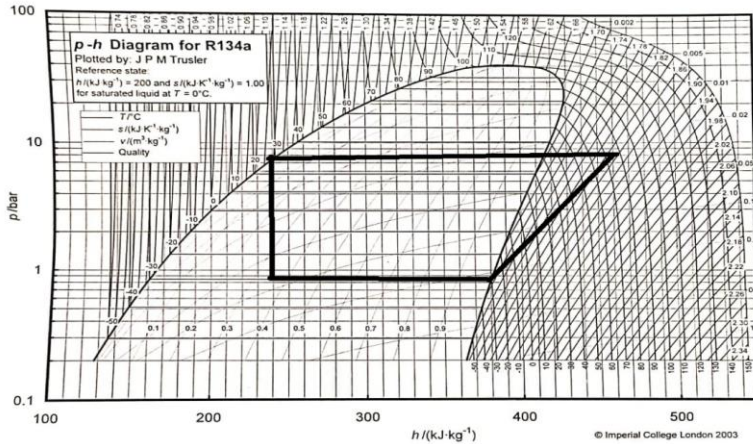

Fig 7: p-h diagram

Energy Consumption:-

Here, Water is heated from 24.3°C to 58.3°C. So required Heat is calculated by,

$$Q = mC\Delta T$$

Where, m = mass of water, (kg)

$$C = \text{latent heat of vaporization, (kJ/kg}^\circ\text{C)}$$

$$= 4.218 \text{ kJ/kg}^\circ\text{C}$$

ΔT = temperature difference.

$$\text{So, } Q = 11.58 * 4.218 * (58.3 - 24.3)$$

$$Q = 1660.71 \text{ kJ}$$

Now, Normal gas stove efficiency is 68% and calorific value of LPG is 46.1 MJ/kg.

Therefore, Required LPG for same energy generation Gas required is 'x' kg.

$$1660.71 = 0.68 * x * 46.1 * 1000$$

$$X = 0.05297 \text{ kg}$$

$$X = 53 \text{ gms (per day)}$$

PaybackPeriod:-

LPG gas price = Rs. 737 / cylinder

Weight of LPG gas in cylinder = 14.2

Price of LPG per kg = Rs. 51.90 /-

$$\text{Now for one year gas require for heat water is costing} = 365 * 0.053 * 51.90$$

$$= \text{Rs. } 1005 / \text{year}$$

So, Capital investment is Rs. 4000/-

$$\text{Payback period} = 4000 / 1005$$

$$= 3.98 \text{ years.}$$

This VCRS based Domestic Water heater saves Rs. 1005/- per every year for one time use water in day.

Conclusion

Comment [U15]: 24.3°C to 58.3°C

Comment [U16]: kJ/kg°C
Apply revision wherever appropriate

Comment [U17]: kJ

Comment [U18]: Recast the conclusion to only emphasize your findings/results

In recent **year** scientific and public awareness on environmental and energy issues has brought in major interest to the research of waste heat recovery in various thermal applications. **In present thesis** focus is on recovery of waste heat of condenser of domestic refrigerator. Hot water is required for various domestic purposes like cleaning of kitchen utensil, bathing, cloth washing etc. The objective of the project is to recovery the waste heat of condenser by incorporating a water cooled condenser with domestic refrigerator. 104 liters of hot water per day at a 45°C can be produced by recovering condenser heat of domestic refrigerator of 165 liters capacity. It was intended to extract the hot water 8 times in a day and hence a storage type water cooled condenser of 13 liters capacity has been designed, fabricated and incorporated with 165 liters domestic refrigerator. To evaluate the performance improvement, the domestic refrigerator was tested with and without modification. Lower power consumption was expected after incorporating water cooled condenser. However, same power consumption was achieved. This may be due to higher ambient temperature while testing the domestic refrigerator with modification. Lower freezer air temperature was achieved with modification compare to without modification. Thus it can be seen that domestic refrigerator cum water heater can produced hot water of about 104 liters per day at free of cost while maintaining the same freezing temperature. This yield to saving of 1660.71 kJ energy per 13 liters of hot water and save Rs. 1005 per year by single heating in a day.

Comment [U19]: years

Comment [U20]: In this present study

References

Son, C. H., & Lee, H. S. (2009). Condensation heat transfer characteristics of R-22, R-134a and R-410A in small diameter tubes. *Heat and mass transfer*, 45, 1153-1166.

Dobson, M. K., Chato, J. C., Wang, S. P., Hinde, D. K., & Gaibel, J. A. (1993). Initial condensation comparison of R-22 with R-134a and R-32/R-125. University of Illinois at Urbana-Champaign (1993b) ACRC TR-41.

Vera-García, F., García-Cascales, J. R., Corberán-Salvador, J. M., González-Maciá, J., & Fuentes-Díaz, D. (2007). Assessment of condensation heat transfer correlations in the modelling of fin and tube heat exchangers. *International journal of refrigeration*, 30(6), 1018-1028.

Aydın, O., & Guessous, L. (2001). Fundamental correlations for laminar and turbulent free convection from a uniformly heated vertical plate. *International journal of heat and mass transfer*, 44(24), 4605-4611.

Chang, Y. S., Kim, M. S., & Ro, S. T. (2000). Performance and heat transfer characteristics of hydrocarbon refrigerants in a heat pump system. *International journal of refrigeration*, 23(3), 232-242.

Makavana, J. M., P. R. Balas, T. L. Dharsenda, U. D. Dobariya, and P. M. Chauhan (2022). "Develop small capacity fixed bed pyrolyser for bio-char production." *Recent Advances in Agricultural Science and Technology for Sustainable India-Part-I*, Pg. 356-366.

Comment [U21]: Only one of the references was cited. Appropriately cite the references.

Update references to include more recent ones.
Only 2 of the references are more recent than 2013

Changhong, P., Yun, G., Suizheng, Q., Dounan, J., &Changhua, N. (2005). Two-phase flow and boiling heat transfer in two vertical narrow annuli. *Nuclear Engineering and Design*, 235(16), 1737-1747.

Kandlikar, S. G. (1990). A general correlation for saturated two-phase flow boiling heat transfer inside horizontal and vertical tubes. Technical report, Mechanical Engineering Department, Rochester.

García-Cascales, J. R., Vera-García, F., Corberán-Salvador, J. M., González-Maciá, J., & Fuentes-Díaz, D. (2007). Assessment of boiling heat transfer correlations in the modelling of fin and tube heat exchangers. *International Journal of Refrigeration*, 30(6), 1004-1017.

Makavana, J. M., Sarsavadia, P. N., & Chauhan, P. M. (2020). Effect of pyrolysis temperature and residence time on bio-char obtained from pyrolysis of shredded cotton stalk. *International Research Journal of Pure and Applied Chemistry*, 21(13), 10-28.

UNDER PEER REVIEW