

Original Research Article

Cosmic Ray Detector Using Geiger Tubes and Coincident Pulses

Abstract: Cosmic Rays (CRs) are extreme strength particles resigning from outside the Earth and transported through space. These atoms can considerably impact human fitness, aviation and photo electric suppliers. A high energy radiation from space indicator is a tool that detects and measures the force of limitless beams. In this project, one can build a high energy radiation from space indicator utilizing two Geiger Muller tubes, Lead sheets, a stiff frame, a Microcontroller and a Protractor to regulate the frame at certain angle. At different altitudes, at different temperatures, at different humidities, we can identify and record CRs. A portable Muon Detector project that incorporates two Geiger Tubes enclosed within a lead sheet for detecting CRs. The system utilizes a coincidence circuit login to enhance the detection accuracy and reduce false positive rates. Additionally, the device is equipped with sensors to collect data on Temperature, Humidity, Latitude, Longitude and Atmospheric Pressure. The combination of these features provides a comprehensive and versatile solution for studying Muons and their interactions with the surrounding environment. Key words: Cosmic Rays, Geiger Muller tubes, Lead sheets, Microcontroller, Protractor.

Introduction

CRs give one of our many direct samples of matter from outside the solar system. They are high energy particles that travel through atmosphere at nearly the velocity of light. Utmost CRs are infinitesimal capitals stripped of their titles with protons (Hydrogen capitals) being the most abundant type that capitals of rudiments as heavy as lead have been measured. Within CRs still we also find other sub-atomic particles like neutrons, electrons and neutrinos.

Since the CRs are charged – appreciatively charged protons or capitals or negatively charged electrons, their paths through space

can be veered by glamorous fields (except for loftiest energy CRs). On their trip to Earth, the glamorous fields of the world, the solar system, and Earth scramble their flight paths so much that one can no longer know exactly where they are originating from. That means that we have to determine where CRs come from by circular means.

One way one can learn about CRs is by studying their composition. About 90% of CRs are Hydrogen (Protons), 9% are Helium and all the rest of the rudiments make up only 1%. Indeed, in this one percent there are veritably rare rudiments and isotopes.

Even if we cannot trace CRs directly to a source they can still tell us about Cosmic objects from outer space. Utmost galactic CRs are presumably accelerated in the blast swells of winner remnants. The remnants of the explosions expanding shadows of gases and glamorous field, can last for thousands of times, and this is where CRs are accelerated. Bouncing back and forth in the glamorous field of the remnant aimlessly lets some of the patches gain energy and come CRs. Ultimately, they make up enough speed that the remnant can no longer contain them, and they escape into the world.

Procedure

This project aims to build a cosmic ray detector that can detect and measure the intensity of cosmic rays using two Geiger muller tubes, lead sheets, a wooden frame, a microcontroller, and a protractor. The detector will be designed to be portable and easy to use, making it suitable for both indoor and outdoor use.

The following components will be used to build the cosmic ray detector:

1. Two Geiger muller tubes: These will be used to detect the presence of cosmic rays.
2. Lead sheets: These will be used to reduce the background radiation and improve the detector's accuracy.
3. Wooden frame: The frame will hold the Geiger muller tubes and lead sheets in place.
4. Microcontroller: The microcontroller will control the detector's operation and display the readings.
5. Protractor: The protractor will adjust the frame at any angle.
6. Power Supply: This powers the entire circuit with 5V supply.

The primary object of this project is to design and develop a portable Muon Detector that can accurately measure and record cosmic rays' events. To achieve this, two Geiger Tubes are strategically positioned within a lead sheet enclosure. The lead sheet acts as a shielding material to minimize the interference from background radiation sources, thus enhancing the device's sensitivity to CRs.

The coincidence circuit logic implemented in the detector plays a crucial role in minimizing

false positives. By requiring both Geiger Tubes to detect a particle simultaneously, the system effectively filters out spurious signals and focuses solely on genuine CR interactions. This logic significantly improves the accuracy and reliability of the detectors' measurements.

Furthermore, the portable Muon Detector is equipped with a suit of environmental sensors to collect auxiliary data. These sensors include Temperature, Longitude, Humidity, atmospheric pressure and Latitude sensors. By integrating these measurements into the device, researchers can correlate Muon detection with the prevailing environmental conditions. This information contributes to a better understanding of how CR events are influenced by various factors such as weather patterns, altitudes and geographical location.

The collected data from the Muon Detector and environmental sensors are stored in an onboard memory module. The device is designed with a user-friendly interface that allows for easy retrieval and analysis of recorded data. Researchers can extract information about muon flux, event rates, and environmental parameters for further investigation and scientific exploration.

Design

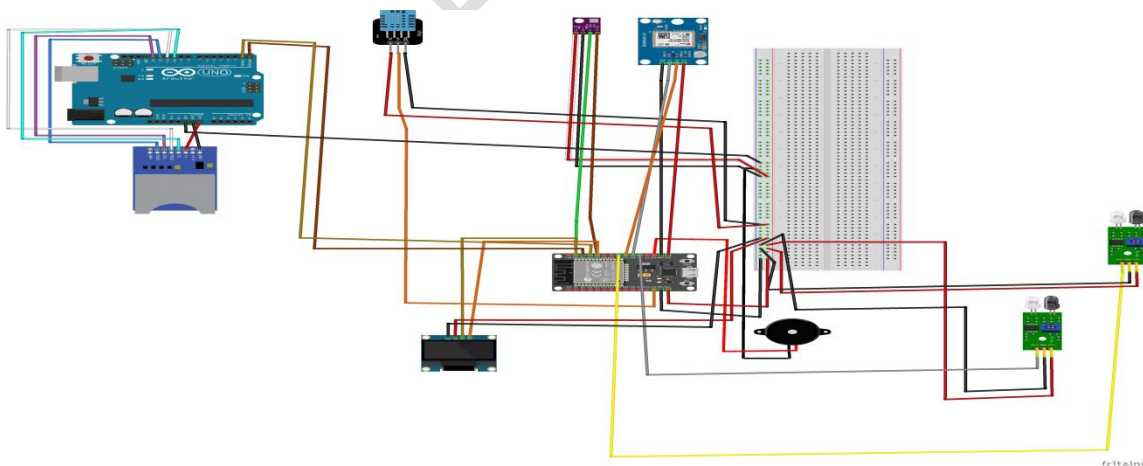

Figure 1: Circuit design for CR Detector

The cosmic ray detector will consist of two Geiger muller tubes mounted on a wooden frame. The tubes will be placed at an angle to each other to enable the detection of cosmic rays from different directions. The frame will

also have lead sheets attached to reduce background radiation. The microcontroller will be connected to the Geiger muller tubes and will read the pulses generated by the tubes when they detect cosmic rays. The microcontroller will then display the readings

on an OLED display. The protractor will adjust the frame at any angle to enable the user to detect cosmic rays from different directions. The wooden frame will also be designed to be

portable and easy to assemble, making it suitable for use in various locations.

A portable Muon Detector project that incorporates two Geiger tubes enclosed within a lead sheet for detecting Cosmic Rays.



Figure 2: Radiation Detector (CRs) Circuit

The Geiger tube can be integrated with one of the following to detect the pulses. To simultaneously detect the pulses, an AND Gate IC is used to make sure that both the tubes detect the pulse simultaneously, giving us an accurate value to ensure that it is a cosmic ray. The research on the difference between M4011 and SBM 20 can be found below

http://www.ggelectronicsllc.com/forum/topic.asp?TOPIC_ID=4571&SearchTerms=ullix,sbm20,m4011

As SBM20 is unavailable in India, and as both have similar sensitivity, we went for M4011 Geiger tubes, two of them.

LEAD Sheets of 1.00mm and 1.5mm are available in India, in various sizes.

A 2sqft sheet of LEAD of both thicknesses is to be tested separately to check which shields the radiation the best.

GPS Neo6M will be installed to get the exact latitude and longitude of the cosmic rays

A digital compass sensor based on magnetometer and accelerometer will be installed to tell the orientation and direction of the cosmic rays

A Digital protractor using accelerometer and gyroscope will be prototyped to check the accuracy of the tilt angle of the cosmic ray detector.

An OLED display is ordered online, which helps in displaying the above parameters, measurements and also the pulse coincidence from both the Geiger tubes.

A microcontroller is necessary to read the pulses and send the trigger to the coincidence circuit. We have ordered an Arduino UNO, ESP8266 and ESP32 to enable these with either wifi or through serial port communication to the OLED display.

What was understood from this is that the Geiger counter circuits are sending pulses that are giving units in CPM (Counts per minute) into Digital Pins 2 and 3 on Arduino

But what we would like to do in this for the coincidence circuit is just detect the interrupts from both pins, and check how they detect the pulse at the same instance.

Before coding with interrupts on the PINS 2 and 3, Arduino UNO is flashed with basic C++ Code used to collect the three parameters from two Geiger tubes, CPM, NSV, USVH

The following program indicates that the detection of CRs from the above said materials.

```
/*!
  @file geiger.ino
  @brief Detect CPM radiation
  intensity, the readings may have a
  large deviation at first, and the
  data tends to be stable after 3
  times
  @copyright Copyright (c) 2010
  DFRobot Co.Ltd
  (http://www.dfrobot.com)
  @licence The MIT License (MIT)
  @author [fengli](li.feng@dfrobot.com)
  @version V1.0
  @date 2021-9-17
  @get from https://www.dfrobot.com

  @https://github.com/DFRobot/DFRobot_
  Geiger

  */

#include <DFRobot_Geiger.h>
#if defined ESP32
#define detect_pin1 D3
#define detect_pin2 D2
#else
```

```
#define detect_pin1 3
#define detect_pin2 2
#endif
#define CosmicPin 7
#include <TinyGPS++.h>
#include <SoftwareSerial.h>
/* Create object named bt of the
class SoftwareSerial */
SoftwareSerial GPS_SoftSerial(4,
3);/* (Rx, Tx) */
/* Create an object named gps of the
class TinyGPSPlus */
TinyGPSPlus gps;

/*!
  @brief Constructor
  @param pin External interrupt pin
  */
DFRobot_Geiger
geiger1(detect_pin1);
DFRobot_Geiger
geiger2(detect_pin2);
void setup()
{
  Serial.begin(115200);
  //Start counting, enable external
  interrupt
  geiger1.start();
  geiger2.start();
  pinMode(CosmicPin, INPUT);
}
void loop() {

  //Start counting, enable external
  interrupt
  //geiger.start();
  delay(3000);
  Serial.print("Cosmic Ray is ");

  Serial.println(digitalRead(CosmicPin
));
```



Figure 3: A Geiger tube with assembled Geiger counter circuit

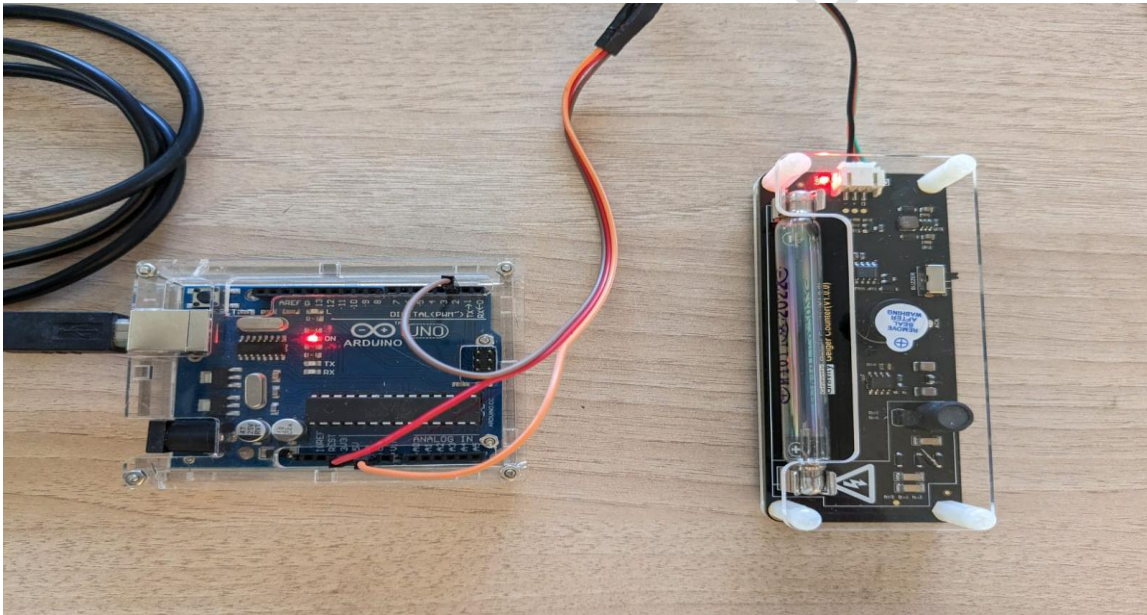

Figure 4: Circuit connection to interrupt PIN 3 on Arduino UNO

```

Coding with two Geiger Tube counters
const int ledPin = 13;    // LED connected to
digital pin 13
const int buzzerPin = 9;  // Buzzer connected
to digital pin 9
const int interruptPin2 = 2; // Interrupt pin 2
const int interruptPin3 = 3; // Interrupt pin 3
volatile unsigned long time2 = 0; // Time of
last interrupt on pin 2
volatile unsigned long time3 = 0; // Time of
last interrupt on pin 3
volatile boolean flag2 = false; // Flag to
indicate pin 2 has interrupted

```

```

volatile boolean flag3 = false; // Flag to
indicate pin 3 has interrupted
void setup() {
  pinMode(ledPin, OUTPUT);    // set the
LED pin mode
  pinMode(buzzerPin, OUTPUT); // set the
Buzzer pin mode
  pinMode(interruptPin2, INPUT); // set pin 2
as input
  pinMode(interruptPin3, INPUT); // set pin 3
as input

  attachInterrupt(digitalPinToInterrupt(interrupt

```

```
Pin2), interrupt2, RISING); // interrupt on pin 2
```

```
attachInterrupt(digitalPinToInterrupt(interruptPin3), interrupt3, RISING); // interrupt on pin 3
Serial.begin(9600); // initialize serial communication
}
void loop() {
  if (flag2 && flag3 && (time2 == time3)) { // check if both interrupts have occurred and happened at the same time
    digitalWrite(ledPin, HIGH); // turn on LED
    tone(buzzerPin, 1000, 500); // play buzzer at 1 kHz for 500 ms
    Serial.println("Interrupts occurred at the same time!");
    flag2 = false; // reset flags
    flag3 = false;
  }
}
void interrupt2() {
  time2 = micros(); // record the time of the interrupt
  flag2 = true; // set flag to indicate that an interrupt on pin 2 occurred
}
void interrupt3() {
  time3 = micros(); // record the time of the interrupt
  flag3 = true; // set flag to indicate that an interrupt on pin 3 occurred
}
```

This code uses the Tiny GPS++ library to communicate with the NEO-6M GPS module, the Adafruit GFX and Adafruit_SSD1306 libraries to communicate with the OLED display, and the SD library to communicate with the microSD card reader and microSD module. The setup function initializes the GPS module, OLED display, and microSD card, and creates a new file to store the GPS data. The loop function continuously reads GPS data, updates the OLED display with the latitude, longitude, and altitude, and writes the data to the microSD card file.

Here's a code that lights up an LED and plays a buzzer when a digital interrupt from PINS 2 and 3 occur at the exact same timing in microseconds on an Arduino UNO:

arduino

Copy code

```
const int ledPin = 13; // LED connected to digital pin 13
const int buzzerPin = 9; // Buzzer connected to digital pin 9
const int interruptPin2 = 2; // Interrupt pin 2
const int interruptPin3 = 3; // Interrupt pin 3
volatile unsigned long time2 = 0; // Time of last interrupt on pin 2
volatile unsigned long time3 = 0; // Time of last interrupt on pin 3
volatile boolean flag2 = false; // Flag to indicate pin 2 has interrupted
volatile boolean flag3 = false; // Flag to indicate pin 3 has interrupted
void setup() {
  pinMode(ledPin, OUTPUT); // set the LED pin mode
  pinMode(buzzerPin, OUTPUT); // set the Buzzer pin mode
  pinMode(interruptPin2, INPUT); // set pin 2 as input
  pinMode(interruptPin3, INPUT); // set pin 3 as input
  attachInterrupt(digitalPinToInterrupt(interruptPin2), interrupt2, RISING); // interrupt on pin 2
  attachInterrupt(digitalPinToInterrupt(interruptPin3), interrupt3, RISING); // interrupt on pin 3
  Serial.begin(9600); // initialize serial communication
}
void loop() {
  if (flag2 && flag3 && (time2 == time3)) { // check if both interrupts have occurred and happened at the same time
    digitalWrite(ledPin, HIGH); // turn on LED
    tone(buzzerPin, 1000, 500); // play buzzer at 1 kHz for 500 ms
    Serial.println("Interrupts occurred at the same time!");
    flag2 = false; // reset flags
    flag3 = false;
  }
}
void interrupt2() {
  time2 = micros(); // record the time of the interrupt
  flag2 = true; // set flag to indicate that an interrupt on pin 2 occurred
}
```

```

void interrupt3() {
  time3 = micros(); // record the time of the
interrupt
  flag3 = true;    // set flag to indicate that an
interrupt on pin 3 occurred
}

```

In this code, we declare the pins that we are going to use and initialize them in the setup function. We then attach interrupts to pins 2 and 3 using the attach Interrupt function. These interrupts are set to trigger on the rising edge of the input signal.

The interrupt2 and interrupt3 functions are called when the interrupts occur on pins 2 and 3, respectively. These functions record the current time in microseconds using the micros () function and set the corresponding flag to indicate that an interrupt has occurred.

In the loop function, we check if both flags have been set and if the interrupts occurred at the same time. If so, we turn on the LED and play the buzzer for 500 milliseconds using the tone () function.

Finally, we reset the flags to prepare for the next set of interrupts.

Note that we also print a message to the serial monitor to indicate when the interrupts occurred at the same time. This is useful for debugging and verifying that the code is working as expected.

Applications

The portability of the Muon Detector makes it an invaluable tool for researchers in various fields, including Astrophysics, Atmospheric Sciences and Particle Physics. Its compact size and robust construction allow for fieldwork, enabling measurements to be taken in diverse locations and conditions. The real-time monitoring of CR events and environmental parameters offers researchers to observe the dynamic nature of muon flux and its correlation with atmospheric conditions.

Results and Conclusion

By considering the Time and Humidity, most of the CRs are detected at high Humidity i.e., from 50 to 75. The less no. of CRs detected at low Humidity in 24 hours. By considering Time and Temperature, most of the CRs detected at moderate temperature. If temperature increases the detection of Cosmic Rays are also increases.

At high altitude, the detection of CRs is very high due to high ionization of gases. Hence Vector Hess found the CRs using balloons at high altitudes. It is possible to find the Cosmic Rays at normal atmosphere depend on different factors altitude, humidity, temperature etc.,

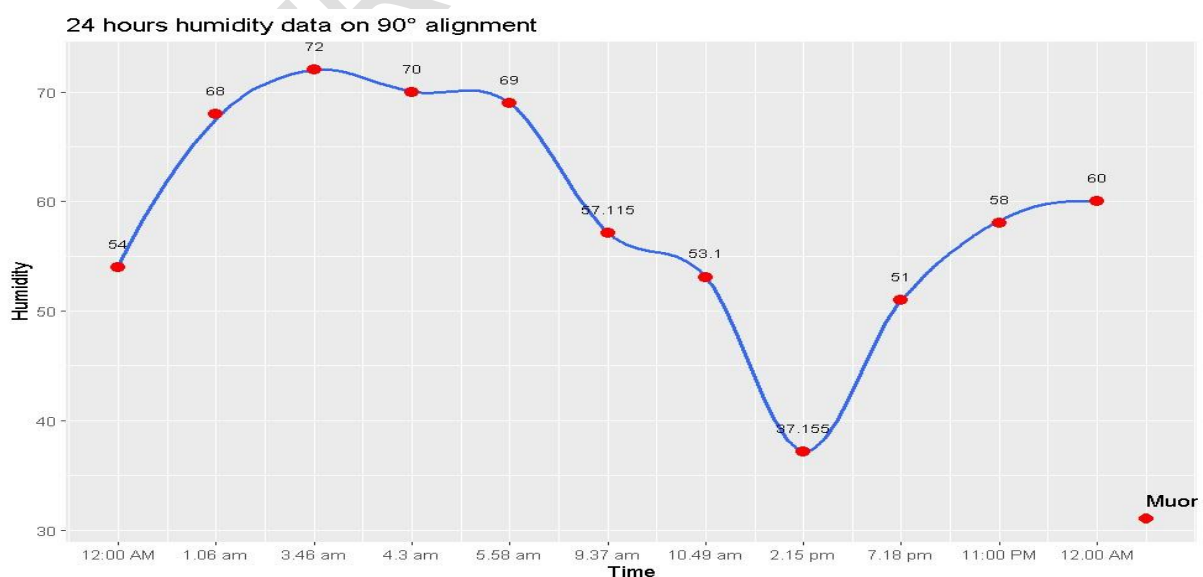

Graph 1 : 24 hours Humidity data on 90⁰ alignment

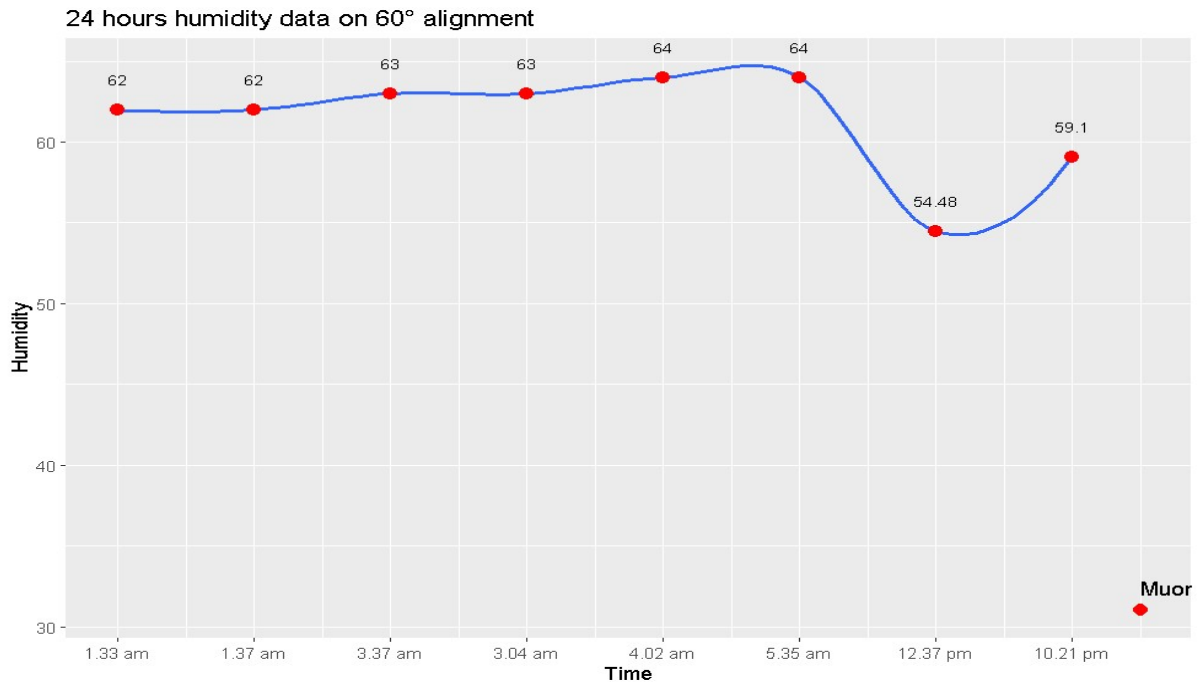

Graph 2: 24 hours Humidity data on 60° alignments

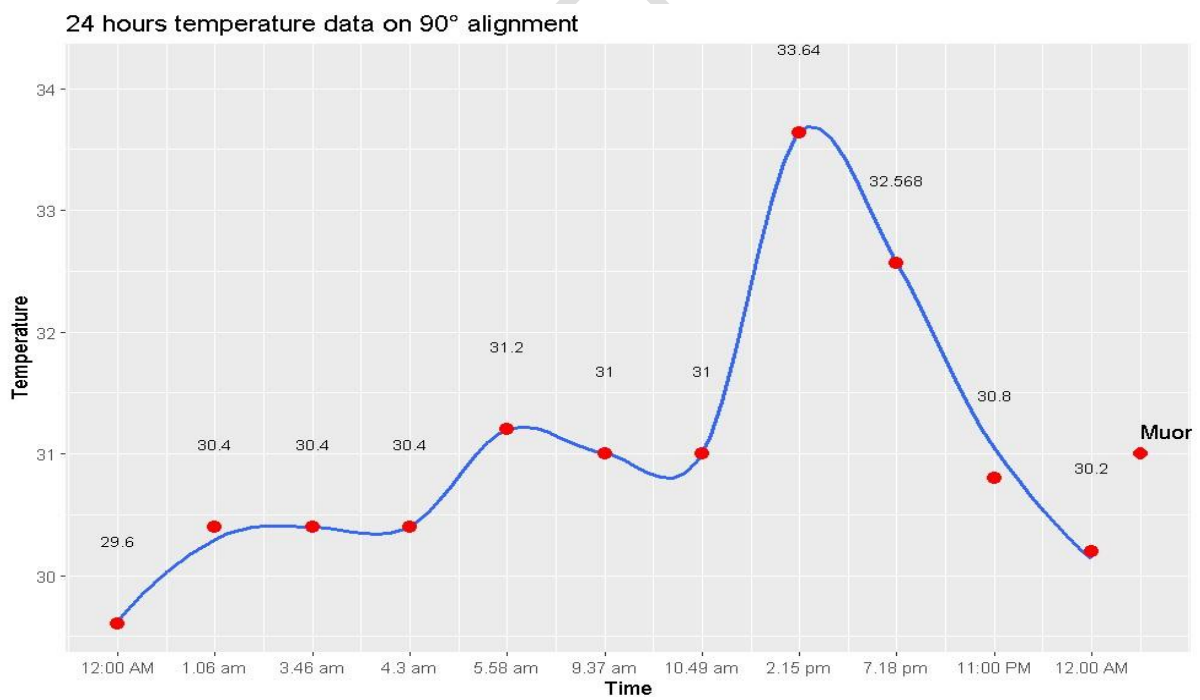

Graph 3: 24 hours temperature dat on 90° alignment

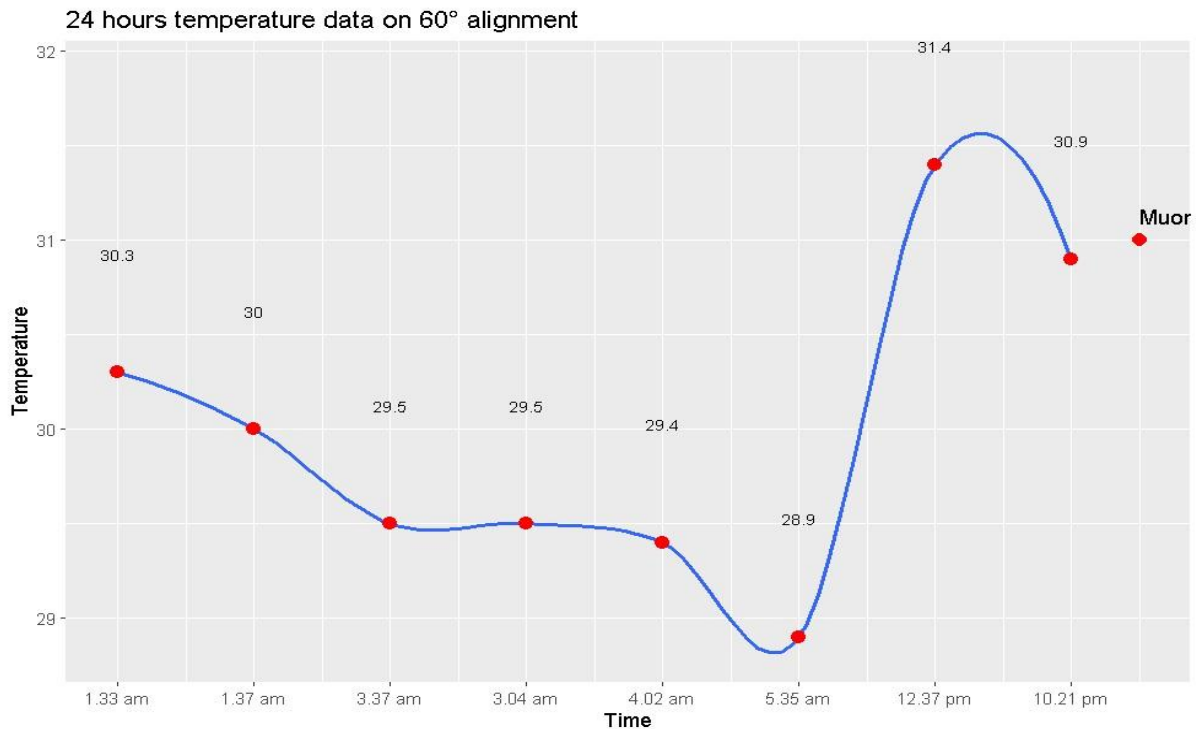

Graph 4: 24 hours temperature data on 60° alignment

In conclusion, the portable Muon Detector project described in this abstract offers a comprehensive solution for studying Muons and their interactions with the environment. By utilizing two Geiger tubes covered by a lead sheet and employing coincidence circuit logic, the system ensures accurate detection and minimizes false positives. The inclusion of temperature, Humidity, Latitude, Longitude and Atmospheric Pressure sensors enables researches to gather valuable environmental data. The devices' portability further enhances its versatility, allowing for fieldwork and real-time monitoring. This project presents an invaluable tool for advancing our understanding of CR phenomena and their relationship with the surrounding world.

References

- [https://www.semanticscholar.org/paper/Cosmic-Ray-Muon-Detection-Boulicaut/eb9446fcc3e00e0d53516b972e407654b4074fda](https://www.semanticscholar.org/paper/ Cosmic-Ray-Muon-Detection-Boulicaut/eb9446fcc3e00e0d53516b972e407654b4074fda)
- <https://www.mdpi.com/2073-8994/14/3/500>
- https://www.researchgate.net/publication/308202163_AMD5_an_educational_cosmic_ray_detector
- <https://arxiv.org/pdf/physics/0701015>
- <https://physicsopenlab.org/2016/01/02/cosmic-rays-coincidence/>
- <https://www.elektormagazine.com/labs/dual-geiger-muller-tube-radiation-sensor-for-arduino>
- <https://timeline.web.cern.ch/geiger-muller-counters-and-coincidence-technique>
- <https://www.hardhack.org.au/book/export/html/52>
- <https://www.giangrandi.org/electronics/twin-tube-geiger/twin-tube-geiger.shtml>
- <http://hyperphysics.phy-astr.gsu.edu/hbase/Astro/cosmic.html>
- <https://forum.arduino.cc/t/using-multiple-geiger-counters-at-once/1081804/3>
- <https://hackaday.io/project/16568/logs?sort=oldest&page=3>

- [13] Elise Le Boulicaut, Cosmic Ray Muon Detection, Gustavus Adolphus College May 29, 2018
- [14] Tadeusz Wibig and Michał Karbowski, CREDO-Maze Cosmic Ray Mini-Array for Educational Purposes, MDPI, <https://doi.org/10.3390/sym14030500>, 28 February 2022
- [15] Axani S.N., Conrad J.M., and Kirby C. The Desktop Muon Detector: A simple, physics motivated machine and electronics shop project for university students. Massachusetts Institute of Technology. <http://studylib.net/doc/18745059/axiv-1606.01196v3--physics.ed-ph--25-aug-2016>
- [16] Beer's law. <https://www.britannica.com/science/Beers-law>
- [17] Beringer J. et al. (Particle Data Group). Passage of particles through matter. Phys. Rev. D 86, 2012.
- [18] Carlson, P. and Watson, A. A. Erich Regener and the ionisation maximum of the atmosphere. Hist. Geo Space Sc 5, 2014.
- [19] Cosmic Rays. The Great Soviet Encyclopedia, 3rd Edition, 1979.
- [20] Density of air. https://en.wikipedia.org/wiki/Density_of_air
- [21] Easwar, N. and MacIntire, D.A. Study of the Effect of Relativistic Time Dilation on Cosmic Ray Muon Flux - An undergraduate modern physics experiment. Am. J. Phys 59 (7), 1991.
- [22] Gaussian distributed random numbers. <https://www.mathworks.com/matlabcentral>
- [23] Ho C.Y.E. Cosmic Ray Muon Detection using NaI Detectors and Plastic Scintillators. University of Virginia. <http://home.fnal.gov/group/WORK/muonDetection.pdf>
- [24] LeCroy Corporation data sheets. <http://teledynelecroy.com/lrs/dsheets/365a1.htm>
- [25] McNichols A.T. Variable Altitude Muon Detection and Energy Dependence of Cosmic Ray Muons. University of Hawai'i. <http://www.spacegrant.hawaii.edu/reports/23SUM14-SP14/AMcNicholsS14.pdf>
- [26] Muon basics. <http://www2.fisica.unlp.edu.ar/veiga/experiments.html>