

*Original Research Article*  
**Under-Voltage Protection of Power Transmission  
Lines**

---

**ABSTRACT**

The continuous monitoring of the protection relay of the transmission line is desirable to ensure the system disturbance such as fault inception is detected in the transmission line. Therefore, the fault on the transmission line needs to be detected, classified, and located accurately to maintain the stability of the system. This paper presents design enhancement and development under voltage relay in power system protection using MATLAB/Simulink. The contacts of the under-voltage relay operate when voltage drops below a set voltage. It is used for protection against voltage drops to detect the short circuit. This work is carried out for all types of faults which only related to one of the parallel transmission lines. In overall operation conditions, the sample data were generated for the system by varying the different fault types and fault locations. This design system proposes the use of the MATLAB/Simulink-based method for fault classification and location of various types of faults.

*Keywords:* Transmission line protection, Under-voltage relay, Fault types.

## 1. INTRODUCTION

The power system continuity is of essential importance in electrical power systems. The parameters that define the quality of a power system are voltage and frequency. Moreover, an upper limit on the current flowing through a power system is also vital to maintain. The operating conditions of a power system and connected loads are not necessarily always predictable, which causes the power system to deviate from its standard operating values. One of many factors greatly affecting the voltage, frequency, and current flow of the power system is the development of faults. The defect in the transmission line that can cause the current to stop flowing through that system is known as fault [1]. Its occurrence can be due to separate conductors, carrying different potentials, coming into contact with one another. Usually, in the cases of faults, an unintended flow of current is established between at least two phases or at least one phase and the ground. As such, a fault that affects every phase similarly is termed as a "symmetrical fault". In the case, where some phases remain unaffected, the fault termed as an "asymmetrical fault", proves difficult in its analysis [2, 3].

One integral component of power systems is the transmission line as it forms an important link to the generating station. The probability of encountering faults is greater in a transmission line, so it's essential to promptly and accurately classify them [4, 5]. Many approaches use a mathematical tool like MATLAB/Simulink, PSIM, and many more to design the under-voltage relay. Furthermore, it also summarizes several past works based on other methods used to classify fault type and designing the under-voltage relay which is related to this work [6-9]. In a circuit transmission line, the fault can damage or disrupt the power system in several ways as fault gives rise to abnormal operating conditions, becomes an unstable system, and can cause the equipment to operate improperly. Within an interconnected power network system, if any type of short-circuit fault occurs both current and voltage deviate from their normal values. So both, the current and voltage can be used to identify the fault and to operate the circuit breaker. Normally, transmission lines have some voltage drop so even in normal conditions, the voltage supplied is slightly less than the normal value. Under voltage, the relay is used for protection to detect the fault location through the distance with the accurate fault type [10-17]. The design system in this paper proposes the use of Matlab/Simulink-based method to design enhancement and development of the under-voltage relay in the power system protection for fast and reliable fault classification and location of various types of fault. The MATLAB/ Simulink software is used to simulate the power system model for the output and input mapping methods. This simulation is covered with several of the fault-types which are line-to-ground (LG), line-to-line (LL) and three-line (LLL) faults, double-line-to-ground (LLG), and three-line-to-ground (LLLG) faults that function at their specific location.

## 2. METHOD

Design backup protection by using an under-voltage relay as shown in Figure 1. Furthermore, analyze the effect of various types of faults at their specific location based on the load voltage profile. The work was implemented by MATLAB/Simulink.

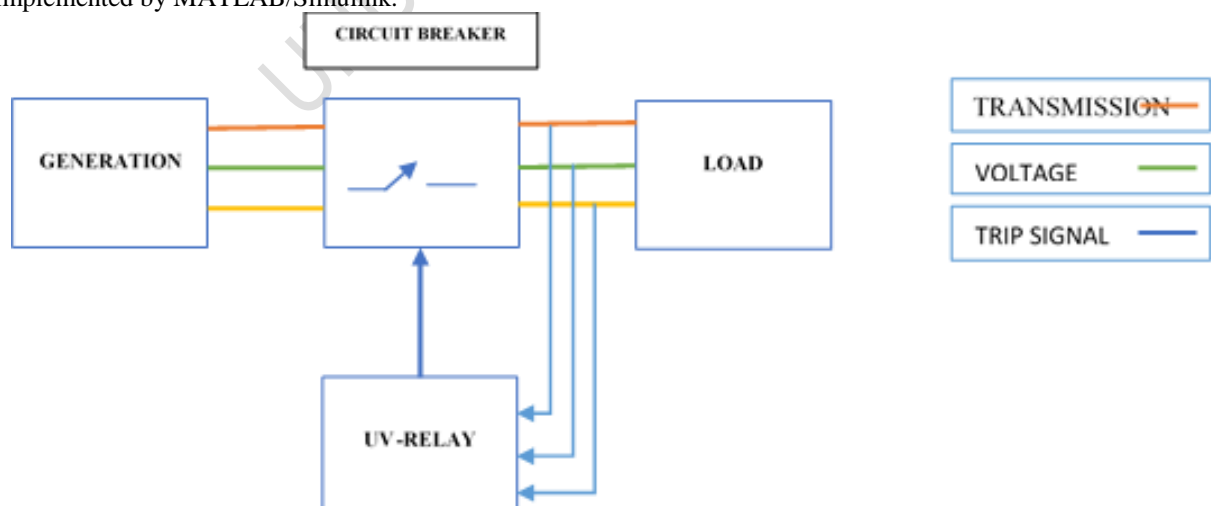

**Fig. 1. Block diagram of the protected system**

Figure 2 provides a general view of different protection system phases that is conducted sequentially to make sure that the protection system achieves its purposes. The power system protection was beginning from generation to load.

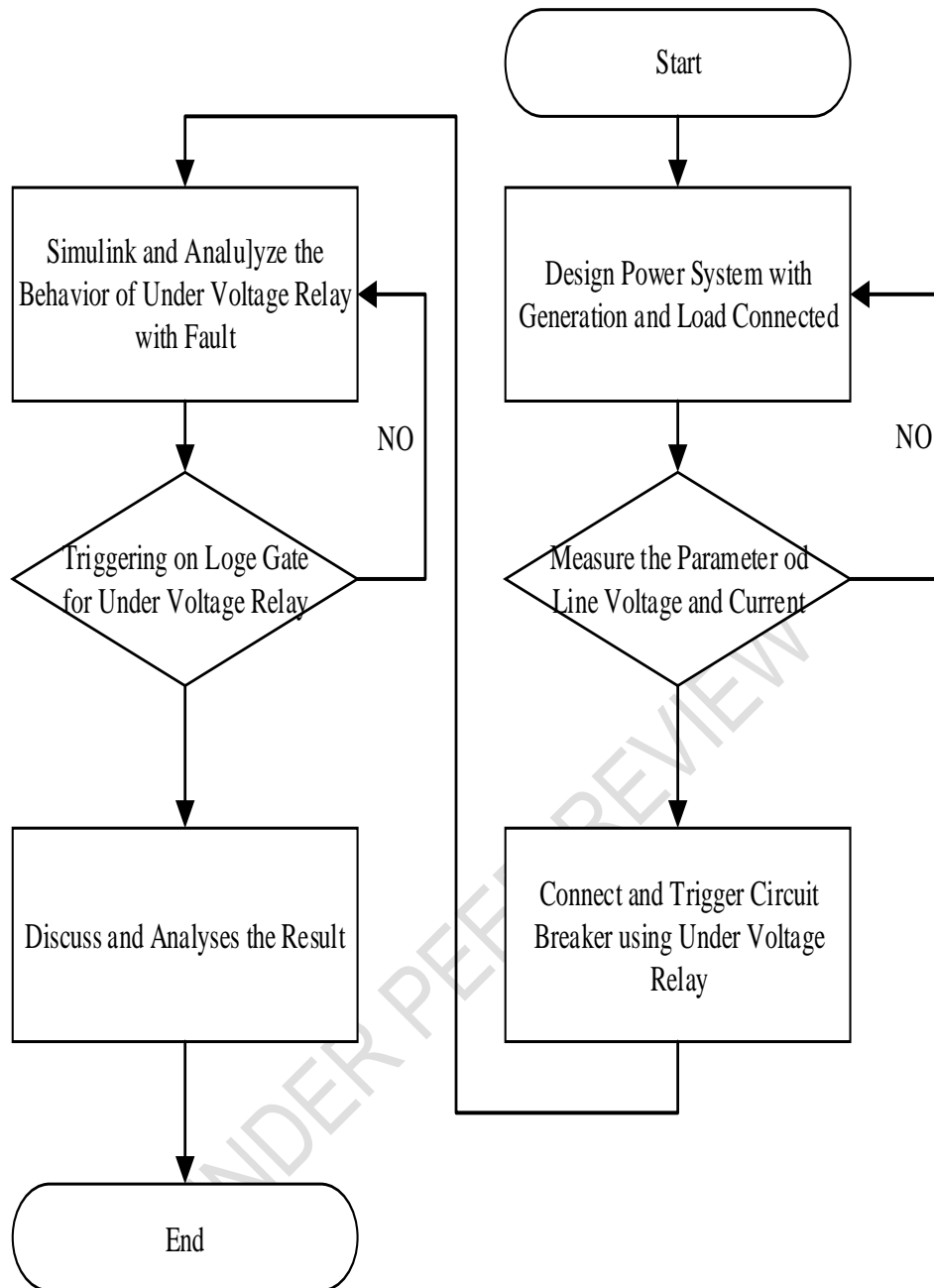

**Fig. 2. General flowchart of protection system design**

The under-voltage relay is designed using logic gates. The flowchart of this algorithm is described in figure 3. The basic algorithm behind its work is explained as:

1. Measure the RMS value of the transmission line.
2. Compare this RMS value with the minimum set value of voltage.
3. If the RMS value is less than the set value for 3ms then trigger the breaker to open state and jump to step 5.
4. If not then keep the breaker in a close state and go back to step 1 for some fault scenario.
5. Then wait for a reset signal to reset the relay back to its original state.
6. Go back to step 1 to repeat this process for some fault cases.

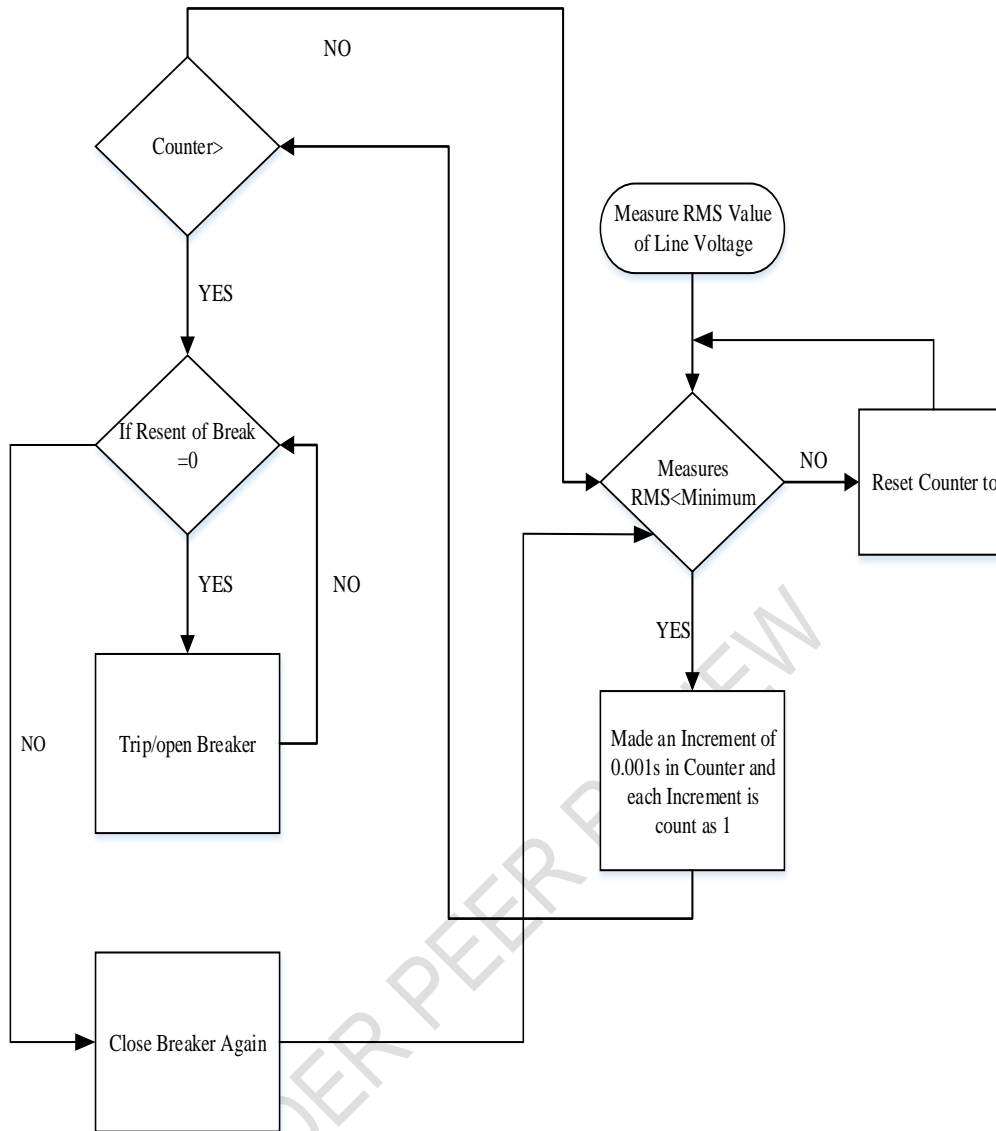

**Fig. 3. Dynamical operation of under voltage relay**

The algorithm explained above is implemented in MATLAB as discussed below:

- Measure the voltage of the transmission line of each phase and convert it into an RMS value.
- Then, RMS voltage is compared with the minimum voltage level set for tripping, which is 100V. The output is inverted.
- The fault that occurred is confirmed by introducing the delay in tripping time. So, a delay of 3ms is introduced using a delay block.
- The output delay is fed into an S-R flip-flop which will decide whether the system should continue to work or stop. At this stage, the output of the delay unit and reset button decided the turning-on status of the relay.

### 3. RESULTS AND DISCUSSION

The simulation can cover all types of fault, but the famous types of fault, which are continuously occurring in the actual electrical power system are single phase to ground fault and three-phase to ground fault.

#### 3.1. Single-Phase-to-ground fault

Single-phase to ground faults occurs when a single phase from the three-phase electrical system comes into contact with the ground causing short-circuit. Figure 4 illustrates the wave-form exhibited by a phase-to-ground fault on a 400V three-phase system, where it can be observed that the A-phase (faulted phase) shows a lower voltage. Additionally, figure 4 represents the stages of the voltage wave-form. The initial two cycles show the pre-fault voltage, the following four cycles show the voltage during the fault, and the last cycle is the post-fault voltage.

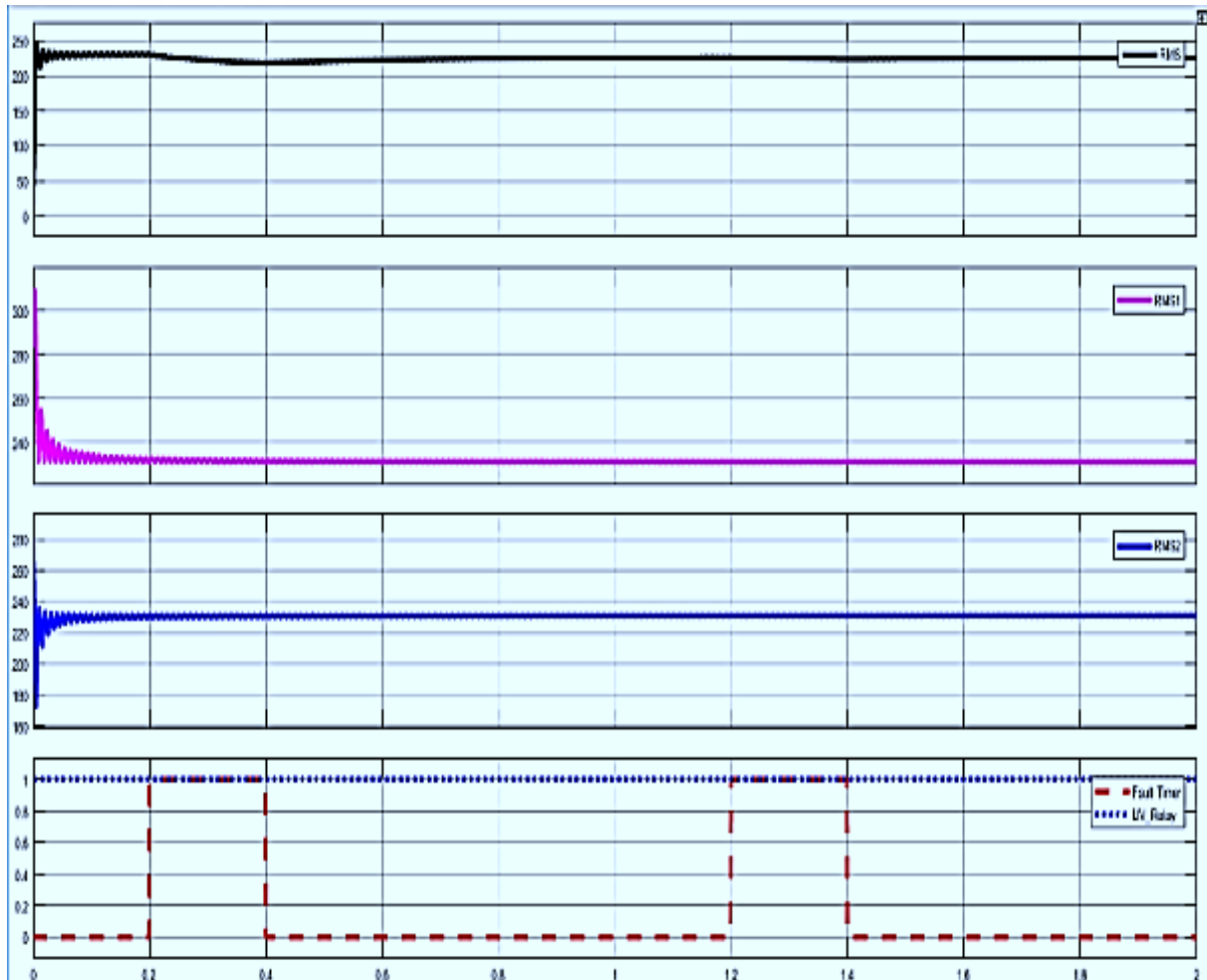

**Fig. 4. Turn-ON phase to ground fault in phase A .**

### **3.2. Three-phase to ground fault**

Figure 5 illustrates the voltage waveforms for a three-phase fault in a 230V electrical system, with the three phases labeled as “A”, “B”, and “C”. The two initial cycles of the diagram show the pre-fault voltage, the following four cycles illustrate the voltage during the fault, and the last cycle shows the post-fault voltage. The peak voltage, marked on the y-axis of the graph that denotes the voltage readings, is found to be 325V ( $230V \times \sqrt{2}$ ) for this system. Likewise, the period of a single cycle, denoted by the x-axis in degrees, is calculated to be 16.7 msec. (1 cycle = 360 degrees). Using satellite clocks the data that may help to analyze the fault is time-stamped, along with the corresponding root-mean-square value of the voltage. The voltage is restored while the current is disrupted in the case the fault is corrected. On the condition that the position of the fault is near the terminals of the transformer, the voltage on all three phases would be negligible throughout the period the fault remains active.

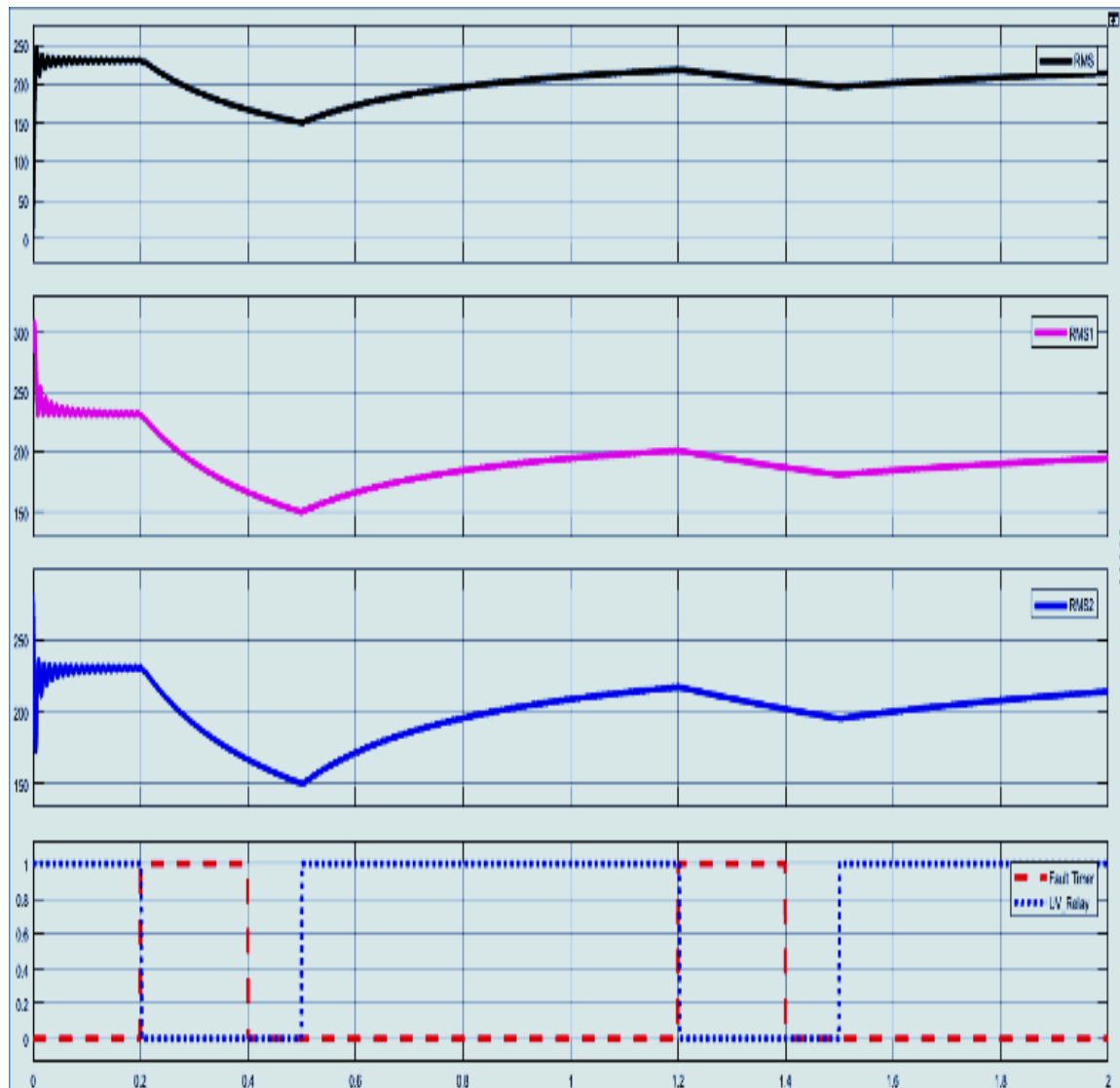

Fig. 5. Turn-ON three-phase to ground faults in phases A, B, and C.

## 5. CONCLUSIONS

The electrical power transmission line is a very important part of the power system, different types of faults have different effects on power system parameters. Therefore, a protection system is greatly required, which monitors the different portions of a power transmission line for different parameters. To analyze the effect of various types of faults (phase to ground fault, phase to phase fault, three-phase fault, double phase to ground fault, and three-phase to a ground fault) at their specific location based on the load voltage profile. The power system under voltage is to design enhancement and development under voltage relay protection using MATLAB/Simulink software. Simulink is a visual simulation tool of MATLAB/Simulink, incorporates power system or algorithm models and export simulation results to MATLAB/Simulink for further analysis

In the circuit of transmission line, the fault can damage or disrupt the power system in several ways such as fault giving rise to abnormal operating conditions becoming an unstable system and can cause the equipment to operate improperly. Under voltage, the relay is used for protection to detect the fault location through the distance with the accurate fault type. This design system proposes the use of the MATLAB/Simulink-based method for fast and reliable fault classification and location for various types of faults.

Identification of faults in power systems can be a challenging task. Usually, phase to ground faults is anticipated as restricted types of faults. The primary focus in categorizing faults in terms of phases and ground is for the calculation of set-points for protective relays, as well as research concerning the transient stability and coordination of these devices. In general, phase-related faults are coupled with phase relays and ground-related faults are coupled with ground relays. Research regarding the transient stability of these relays is directed

towards reducing the time taken to resolve faults or at the very least reducing them to single-line to ground faults, to allow generators both nearby and those at a greater distance to keep synchronization with one another.

## REFERENCE

1. Qingchao Z, Yao Z, Wennand S, and Dazhong F, "Transmission line fault location for a single-phase-to-earth fault on nondirect-ground neutral system," IEEE Trans. Power Delivery, 2008; 13(4): pp. 1086–1092, Oct. DOI: [10.1109/61.714460](https://doi.org/10.1109/61.714460)
2. Kothari DP, Nagrath IJ, Moden, . Power System Analysis. Tata McGraw-Hill.. 694 Pages, ISBN 1259082334, 9781259082337, 2006.
3. Campbell Drive, "What is Undervoltage? How can I protect my equipment?", Available [Online]: <https://www.macromatic.com/blog/relays/what-is-undervoltage>.
4. Narendra KG, Sood VK, Khorasani K, and Patel R, "Application of a radial basis function (RBF) neural network for fault diagnosis in HVDC systems," IEEE Trans. on Power Systems, 2004;13(1): pp.177–183. DOI: [10.1049/ip-gtd:20040098](https://doi.org/10.1049/ip-gtd:20040098).
5. Girgis AA, Hart DG, and Peterson, WL, "A new fault location for two-and-three-terminal lines," IEEE Trans. Power Delivery, 2008;7(1): pp. 98–105. DOI:[10.1109/61.108895](https://doi.org/10.1109/61.108895).
6. Fault location on distribution systems: An update on EPRI and DOE research", IEEE Distribution Subcommittee presentation, Orlando, FL, Jan. 10, 2007. DOI: <http://dx.doi.org/10.15446/ing.investig.v35n1Sup.53673>
7. Circuit globe, "Types of faults in power system", Available [Online]: <http://www.circuitglobe.com>.
8. Oyetunji Samson A., "Real-Time Evaluation of System Dynamics to Improve Network Performance in Akure Electric Power Distribution System in Nigeria",2013. doi:10.5923/j.eee.20130306.03
9. Chen S, Cowan CN, Grant PM, "Orthogonal least squares learning algorithm for training multi-output radial basis function networks," in IEE Proceedings-F., 2012;139(6): pp. 378–384, Dec. 2012. DOI: 10.1109/72.80341.
10. Cheng-Ting Hsu, "Under-voltage relay settings for the tie-lines tripping in an upgrading cogeneration plant" in IEEE Region 10 Conference TENCON, Vol 3, pp.264-267, 2004. DOI: 10.1109/TENCON.2004.1414757.
11. Omer OG, Semra O, and Korhan K, "Performance of an Over/Under Voltage Relay at Non-sinusoidal Conditions" IEEMelecon,2006. DOI:[10.1109/MELCON.2006.1653292](https://doi.org/10.1109/MELCON.2006.1653292)
12. Chen CS, Lee YD, and Hsu CT, "Design of under voltage relay settings for an industrial plant with cogeneration units",2007. DOI:[10.1109/ICPS.2007.4292094](https://doi.org/10.1109/ICPS.2007.4292094)
13. Sharma V. Kolluri R. Ramamurthy, "relay-based Under voltage Load Shedding Scheme for Entergy's Western Region",2015. DOI: [10.1109/PESGM.2015.7285651](https://doi.org/10.1109/PESGM.2015.7285651).
14. Pan J, Xu R, Guo C, and Zhang J, "Design of a High Precision Under voltage Protection Circuit Based on High Voltage BCD Technology," 2020 IEEE 3rd International Conference on Electronics Technology (ICET), 2020, pp. 137-141, DOI: 10.1109/ICET49382.2020.9119559.
15. Ahsan I, Ayesha A, Asad W, Azhar U, Muhammad Z, and Syed H, . Voltage stability enhancement in grid-connected micro-grid using enhanced dynamic voltage restorer (EDVR) [J]. AIMS Energy, 2021;9(1): pp150-177. DOI: 10.3934/energy.2021009.
16. Thamizh TM, and et al., " Implementation of protection circuit for over voltage and under voltage protection", Materials Today:Proceedings, 2021;45(2): pp 2460-2464. <https://doi.org/10.1016/j.matpr.2020.11.022>.
17. Choong-koo C, " Adaptive undervoltage protection scheme for safety bus in nuclear power plants", Journal of Nuclear Engineering and Technology, 2022;54(6): pp 2055-2061. <https://doi.org/10.1016/j.net.2022.01.003>.