

Original Research Article

Synthesis of $\text{Cu}_{2-x}\text{Ni}_{0.05}\text{S}$ ($x = 0.05, 0.25, 0.30$) compounds and study of single crystals

ABSTRACT

In the article, considering the research studies of many scientists and also on the basis of practical applications, the distribution diagram of copper and sulfur atoms in the phase lattice of the Cu_2S crystal, the structure transformation diagram, the elemental lattice hexagonal Cu_2S and $\text{Cu}_{1.96}\text{S}$ crystallographic data were examined and important results were obtained. Analysis of the studies performed shows that some conflicting results in roentgenographic studies on these compounds are related to obtaining these samples by different methods. During the research, it was found that it is possible to buy single crystals of $\text{Cu}_{2-x}\text{Ni}_{0.05}\text{S}$ ($x = 0.05, 0.25, 0.30$) compounds based on the analysis of existing methods and selection of the optimal method. As a result of the research, the suitable lauegrams of the single crystals obtained by the Bridgman method and the microstructures of the samples were determined and the possibilities of application were determined.

Keywords: Crystal lattice, synthesis, combination, microstructure, debaygram, modification.

1. Introduction

Investigation of the crystal structure of Cu_2S : As far as we know, for the first time, N. Alsen showed that Cu_2S crystallizes in a rhombic lattice and the lattice parameters are $a = 11.80 \text{ \AA}, b = 27.20 \text{ \AA}, c = 22.70 \text{ \AA}$ [1,5]. Since it is very difficult to orient the crystal along the c-axis, various values have been obtained for the crystal and therefore these values have been viewed with skepticism. Later, as a result of X-ray studies conducted by M. Burger, he determined that chalcocite really has a rhombic structure. The lattice parameters of Cu_2S according to Burger are as follows: $a = 11.90 \text{ \AA}, b = 27.28 \text{ \AA}, c = 13.41 \text{ \AA}$, space group $A_{bm} 2, z = 96$ Cu_2S [2].

Although many researchers have tried to reveal the crystal structure of Cu_2S , it has not been possible. However, the general result of the conducted research was that S atoms in the structure form a solid framework and Cu atoms are located in the voids. The crystal structure of the low-temperature phase of Cu_2S , was fully determined by N. Evans [3]. He showed that at room temperature Cu_2S , crystallizes in a monoclinic structure and its lattice parameters are $a = 15.246 \text{ \AA}, b = 11.884 \text{ \AA}, c = 13.494 \text{ \AA}$ and $\beta = 116^\circ 35'$. Space group

$$P2_{1/n}, z = 48 \text{ is } \text{Cu}_2\text{S}.$$

The basis of the structure is a hexagonal close-packed framework formed by sulfur atoms. Of the 24 copper atoms, 21 form trigonal Cu_2S groups, and each of the remaining atoms is located at the center of a distorted CuS_4 tetrahedron. Fig.1 shows the distribution scheme of copper and sulfur atoms in the low-temperature phase lattice of Cu_2S along the b axis.

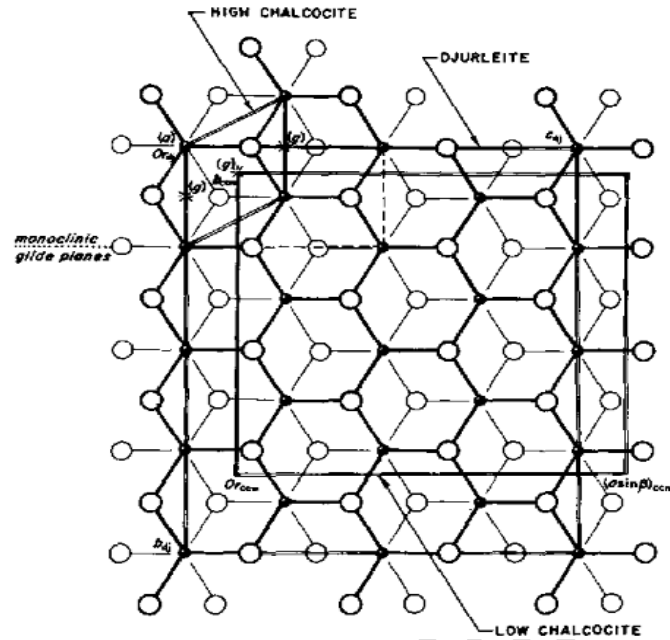

Fig. 1. Distribution scheme of copper and sulfur atoms in the phase lattice

In the structure of the low-temperature phase of Cu_2S , there is only one type of layer of sulfur atoms. However, the fact that copper atoms can easily move between these layers leads to non-stoichiometry and instability of the crystal lattice. Therefore, as a result of a slight temperature change, i.e. at $T = 378 \text{ K}$, the monoclinic lattice is dismantled and a hexagonal lattice is formed. The parameters of this lattice are $a = 3.90 \text{ \AA}$, $c = 6.69 \text{ \AA}$, space group $P6_3/mmm$ $z = 2$, Cu_2S . Based on these results, academician N. Belov discovered the structure of hexagonal Cu_2S [4, 6-9]. Fig.2 shows the elementary lattice of hexagonal Cu_2S .

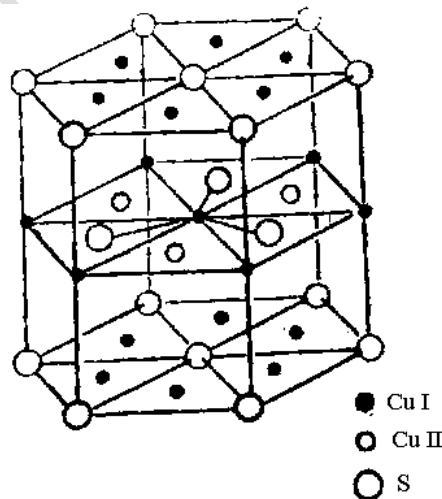

Fig. 2. Unit of hexagonal Cu_2S

The sulfur atoms form a slightly stretched hexagonal close-packed, while the active copper atoms are statistically distributed in three different positions. And Cu^{1+} is located in the center of the tetrahedron. The rest of the copper atoms are localized in the three faces of the tetrahedron formed by the sulfur atoms, statistically connecting one atom in each layer with three atoms in the neighboring layer.

Thus, $a = 3.961 \text{ \AA}$, $c = 6.672 \text{ \AA}$, space group $P6_3/mmc$ was determined for the hexagonal lattice of Cu_2S .

At $T_{\text{trans}} = 738 \text{ K}$, the hexagonal lattice transforms into a face-centered cubic lattice. The parameter of this lattice is $a = 3.961 \text{ \AA}$, space group F_{m3m} , $z = 4$. The crystal lattice is defined as the antiureite type. Here, Ca atoms are replaced by S, and fluorine (F) atoms are replaced by copper (Cu) atoms [10, 11-14].

Thus, from what we have noted, it is clear that two structural transformations occur in Cu_2S crystals from room temperature to melting temperature, and the scheme of these transformations is as follows Fig.3.

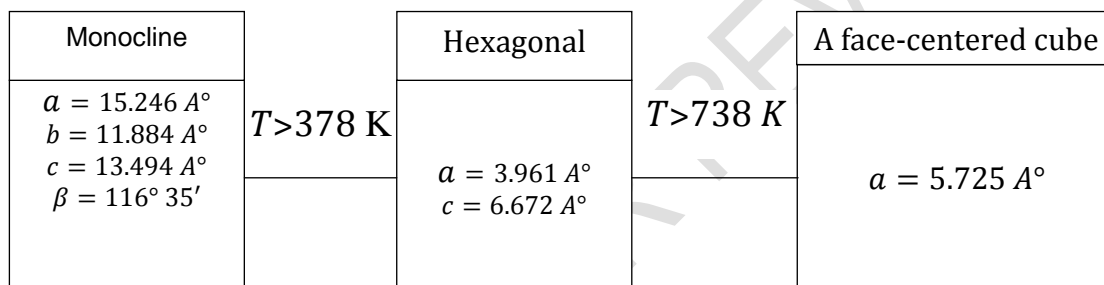

Fig. 3. Scheme of structural transformation of Cu_2S crystal

2. Investigation of the crystal structure of $\text{Cu}_{1.96}\text{S}$

In the future, we noted that there is a compound that exists as an individual non-stoichiometric phase in the Cu – S system, and this fact was confirmed by the X-ray method. An example of this is yurlite ($\text{Cu}_{1.96}\text{S}$). It was determined that the phase of that compound at room temperature had low symmetry, and at the temperature of 377 K it turns into cubic symmetry. At the same time, it was determined that there is a tetragonal phase between the lower and upper temperature phases of yurlite, which can remain metastable for a long time at room temperature.

Later, the idea of a mixture of two phases of yurlite was put forward. For the lattice parameters of the tetragonal phase, $a = 4.008 \text{ \AA}$, $c = 11.268 \text{ \AA}$ were obtained. The unit cell has $z = 4$ ($\text{Cu}_{1.96}\text{S}$) and is in the cubic phase. It is a face-centered cube, the lattice parameter is $a = 5.707 \text{ \AA}$ and $A_{\text{tetr}} = a_{\text{kub}} \sqrt{2}$, $c_{\text{tetr}} = 2a_{\text{kub}}$. Crystallographic data of $\text{Cu}_{1.96}\text{S}$ are given in table 1.

A rhombic structure was also determined for the low temperature phase of yurlite. For the parameters of this lattice $a = 26.92 \text{ \AA}$, $b = 15.71 \text{ \AA}$, $c = 13.56 \text{ \AA}$ phase group $P4_12_12$ was obtained.

Although a group of researchers proposed rhombic syngonia for the low-temperature phase of yurlite, they did not give up on the idea of it having monoclinic syngonia. According to those authors, the space group of this syngonia should be $P2_{1/n}$. Indeed, it was experimentally confirmed and it was shown that yurlite crystallizes in monoclinic syngonia

with space group $P2_1/n$ and lattice parameters $a = 26.89 \text{ \AA}$, $b = 15.745 \text{ \AA}$, $c = 13.565 \text{ \AA}$, $\beta = 90^\circ 13'$, $z = 8$.

Table 1. Crystallographic data of $\text{Cu}_{1.96}\text{S}$.

N	Low temperature phase syngonia	Elementary lattice parameters			Transition temperature T, K	Crystal syngonia of the high temperature phase	Elementary lattice parameters
		$a, \text{ \AA}$	$b, \text{ \AA}$	$c, \text{ \AA}$			
1	Tetragonal	4.008			373	A face-centered cube	5.707
2	Tetragonal	3.996			--	--	
3	Rhombic	Not assigned			364-368	Tetragonal	
4	Rhombic	26.92	15.71	13.56	Not found	Not assigned	
5	Rhombic	Not assigned			366	Not assigned	
6	Rhombic	Not assigned			366	Tetragonal	Not assigned

The distribution of atoms in the crystal structure of the low-temperature modification of yurlite is given in figure 4. As can be seen from the picture, in the crystal structure of yurlite, the layers of sulfur atoms along the b axis form a hexagonal dense assembly. Copper atoms are distributed among these layers in three ways. 51 copper atoms are located in distorted triangles, 9 in tetrahedral space, and one in double coordination.

The coverage of copper atoms in the crystal lattices of the considered compounds is almost the same. Therefore, these cages have many similarities. However, when these cages are carefully examined, it is found that there are enough differences.

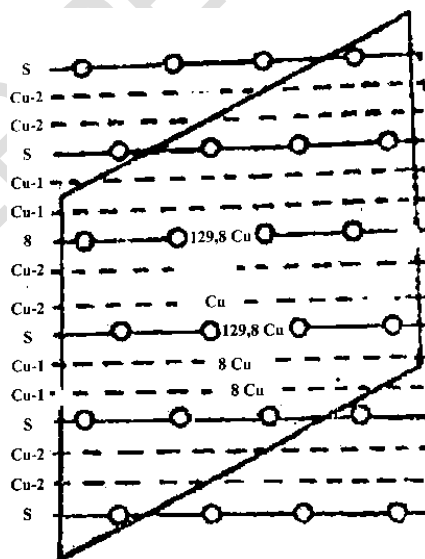

Fig. 4. Distribution of atoms in the crystal structure of low temperature modification of yurlite

3. Synthesis of $\text{Cu}_{2-x}\text{Ni}_{0.05}\text{S}$ ($x = 0.05, 0.25, 0.30$) and obtaining single crystals.

A single method for the synthesis of non-stoichiometric compounds of the $Cu - S$ system has not been proposed in the literature. One group of researchers has used natural crystals, while others have thermally processed the components by mixing them in the form of rubs to obtain the desired phases of different compositions. In some cases, ampoules with appropriate components were heated at $593 - 743 K$ for 7 days, and in other cases, Cu and S components were selected in required percentages and heated to $773 - 873 K$ for 24 hours. Otherwise, Cu and S were stored in a $723 K$ treps ampoule for 7 days.

In another experiment, a pressed mixture of Cu_2S and CuS was placed in an open glass ampoule and heated at $363 K$ for 12 hours. Some authors obtained non-stoichiometric compounds of the $Cu - S$ system by careless cooling.

In order to obtain homogeneous samples, direct synthesis, i.e. chemical interaction of primary components, is more convenient. At this time, quartz ampoules are used as reactors. These ampoules have an inner diameter of $1.5 cm$, a length of $10 cm$, and are heat resistant. Electrolytic Cu , "O4" brand S , "X4" brand Ni are introduced into the required amount of ampoules and the air of the ampoules is sucked up to $10 - 5 mm Hg$.

Ampoules with the appropriate ingredients are inserted into the stable zone of the oven. The temperature of the furnace is raised to the melting temperature of sulfur ($393 K$) and kept at that temperature for 3 hours. This melting allows the sulfur to fully interact with the copper and nickel and at the same time prevents the ampoule from exploding. Then the furnace temperature is raised to the melting temperature of Cu_2S ($1403 K$) at 500 per hour. The sample is kept at this temperature for 2 hours, then it is cooled down to approximately $373 K$, and it is heated at that temperature for 300 hours.

The defectivity of the non-stoichiometric combination of $Cu_{2-x}Ni_{0.05}S$ required the application of a combination of experimentally determined Bridgman and neglect cooling methods to obtain their single crystals.

The various synthesized compositions of $Cu_{2-x}Ni_{0.05}S$ were inserted into a quartz tube $10 cm$ long and $1 cm$ inner diameter specially prepared for the Bridgman method, and the air was blown up to $10 - 5 mm Hg$. The ampoule is inserted into the oven (Fig.5.), where the required temperature is regulated by a thermostat. The temperature of the main furnace is raised above the melting temperature of Cu_2S and after the sample is kept at that temperature for 3 hours, the electric motor is connected and the ampoule is lowered into the electrofurnace at a speed of $6 mm/h$ and baked there at a temperature of $573 K$ for 3 weeks. This temperature corresponds to the temperature of the lower zone of the furnace.

The various synthesized compositions of $Cu_{2-x}Ni_{0.05}S$ were inserted into a quartz tube $10 cm$ long and $1 cm$ inner diameter specially prepared for the Bridgman method, and the air was blown up to $10 - 5 mm Hg$. The ampoule is inserted into the oven (Fig.5.), where the required temperature is regulated by a thermostat. The temperature of the main furnace is raised above the melting temperature of Cu_2S and after the sample is kept at that temperature for 3 hours, the electric motor is connected and the ampoule is lowered into the electrofurnace at a speed of $6 mm/h$ and baked there at a temperature of $573 K$ for 3 weeks. This temperature corresponds to the temperature of the lower zone of the furnace.

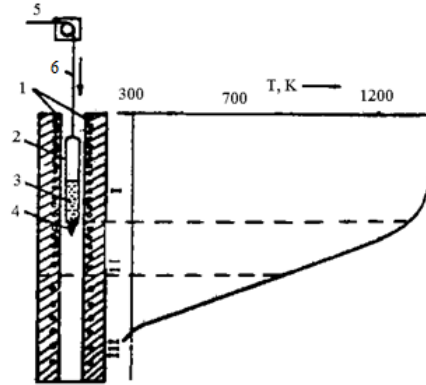
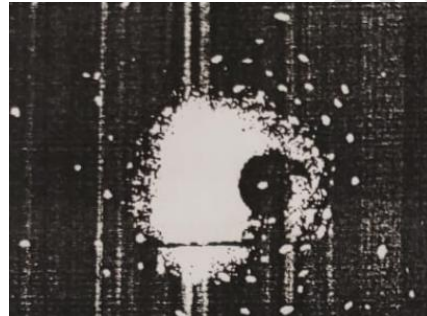
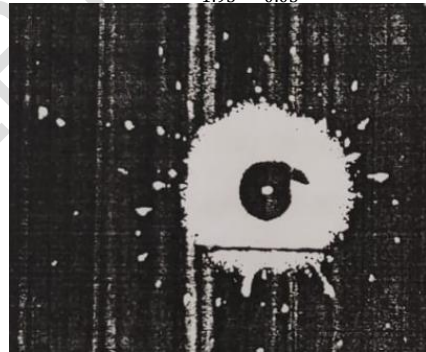

Fig. 5. 1-furnace, 2-ampoule, 3-alloy, 4-tip of the ampoule, 5-electric motor, 6-wire.

Thus, with the help of the method described below, single crystals can be obtained. Figure 6 shows the lauegrams of $\text{Cu}_{2-x}\text{Ni}_{0.05}\text{S}$ ($x = 0.05, 0.25, 0.30$) crystals taken at room temperature. It can be seen from those lauegrams that the obtained samples are monocrystalline.



1 - $\text{Cu}_{1.95}\text{Ni}_{0.05}\text{S}$



2 - $\text{Cu}_{1.75}\text{Ni}_{0.05}\text{S}$

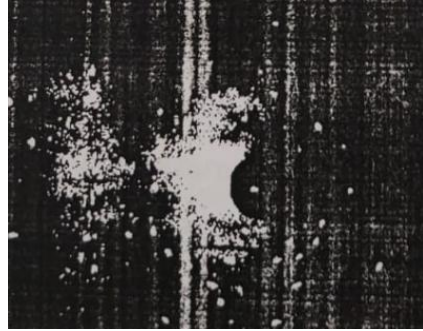

3 – $\text{Cu}_{1.70}\text{Ni}_{0.05}\text{S}$

Fig. 6. Single crystals and their corresponding lauegrams.

4. Microstructures of samples

In order to conduct the microstructural analysis of the received samples, samples are prepared from the synthesized components. After grinding and polishing those samples, their surfaces are washed with ethyl alcohol and dried. Experimentally, 50% HNO_3 + 50% H_2O is selected as an abrasive and 5% acetic acid is added to it. The purpose of making this addition is to prevent oxidation. Figure 7 shows the microstructure of $\text{Cu}_{1.95}\text{Ni}_{0.05}\text{S}$, $\text{Cu}_{1.75}\text{Ni}_{0.05}\text{S}$, $\text{Cu}_{1.70}\text{Ni}_{0.05}\text{S}$ compounds. Debyeograms taken from those samples show that all of them are single-phase at room temperature and have a monoclinic lattice. The parameters of that lattice are $a = 26.897 \text{ \AA}$, $b = 15.745 \text{ \AA}$, $c = 13.565 \text{ \AA}$, $\beta = 90^\circ 30'$, space group $\text{P2}_{1/n}$.

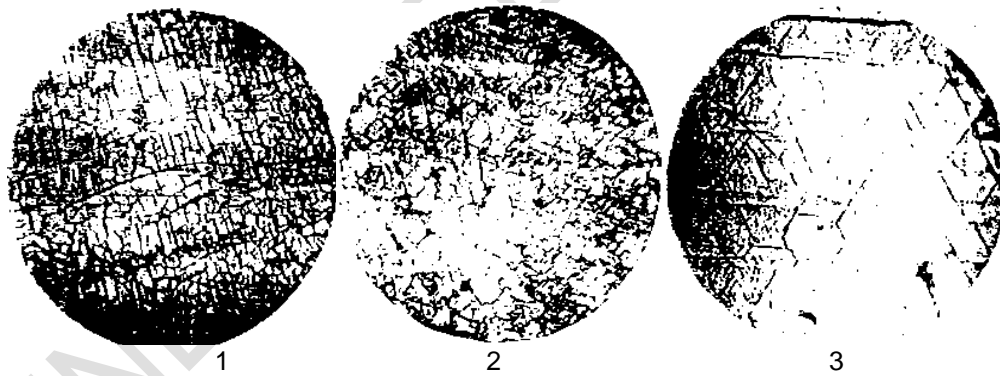

Fig. 7. Microstructure of $\text{Cu}_{2-x}\text{Ni}_{0.05}\text{S}$ compounds (debyeograms)

1 – $\text{Cu}_{1.95}\text{Ni}_{0.05}\text{S}$, 2 – $\text{Cu}_{1.75}\text{Ni}_{0.05}\text{S}$, 3 – $\text{Cu}_{1.70}\text{Ni}_{0.05}\text{S}$

5. CONCLUSION

1. $\text{Cu}_{1.95}\text{Ni}_{0.05}\text{S}$, $\text{Cu}_{1.75}\text{Ni}_{0.05}\text{S}$, $\text{Cu}_{1.70}\text{Ni}_{0.05}\text{S}$ samples were obtained by Bridgeman method.
2. Lauegrams of $\text{Cu}_{2-x}\text{Ni}_{0.05}\text{S}$ ($x = 0.05, 0.25, 0.30$) crystals were taken at room temperature, and those Lauegrams give us the reason that the samples are single crystals.
3. The microstructure analysis of the obtained samples was carried out and it can be seen from the debyeograms that $\text{Cu}_{1.75}\text{Ni}_{0.05}\text{S}$, $\text{Cu}_{1.70}\text{Ni}_{0.05}\text{S}$ compounds are single-phase at room temperature and have a monoclinic lattice. At the transition temperature in $\text{Cu}_{1.70}\text{Ni}_{0.05}\text{S}$, the monoclinic lattice transforms into a face-centered cubic lattice ($a = 5.596 \text{ \AA}$, space group

Fm3m). In the other two samples, the monoclinic lattice changes to a hexagonal lattice ($\text{Cu}_{1.95}\text{Ni}_{0.05}\text{S}$) and a tetragonal lattice ($\text{Cu}_{1.75}\text{Ni}_{0.05}\text{S}$) and becomes a face-centered cubic lattice.

REFERENCES

1. Alsen, Ueber die kristallstruktur von covellin (CuS) und kupferglanz (Cu_2S) Geol. for. Stockholm, v53, 1931, pp. 111-120.
2. N. Burger. X-ray evidence of the existence of mineral digenite, Cu_9S_5 -Am.Miner., v27, 1942, p712-716.
3. H. Evans, Zt. Krist, The crystal structures of low chalcocite and dyscolite, 3d 150, h 1-4, 1970, p299-320.
4. N. V. Belov and V. A. Butuzov, Sekulek of high-temperature chalcocite Cu_2S . DAN USSR, 54, 8, 1964, pp. 717-721.
5. Kh. Kh. Hashimov. Investigation of crystal structure and polymorphic transformations of Cu-S system compounds. V International Scientific and Practical Conference «Modern science: actual problems», Manchester, 2023, p56-60.
6. Islamov I.J., Shukurov N.M. Abdullayev, R.Sh. Hashimov, Kh.Kh. Khalilov, A.I.: Diffraction of electromagnetic waves of rectangular waveguides with a longitudinal. In: IEEE Conferences 2020 Wave Electronics and its Application in Information and Telecommunication.
7. Systems (WECONF), INSPEC Accession Number: 19806145 (2020).
8. I. J. Islamov, E. A. Mammadov, A. R. Rustamov, Kh. Kh. Hashimov, H. Sh. Nabiyev A.I.: Simulation of an Antenna Device with Frequency Scanning International Symposium for Production Research, SCOPUS, Science Citation Index Expanded, IEEE, Springer Antalya 2022, pp. 594-606.
9. A. F. Gochuyeva, Kh. Kh. Hashimov, I. Y. Bayramov, Photoelectret effect in polymer-AIBVI (CdS , ZnS) composites of photosensitive semiconductors / Chalcogenide Letters, vol.20, No.4, pp. 285-291, 2023. <https://doi.org/10.15251/CL.2023.204.285>
10. Kh. Kh. Hashimov, Investigation of crystal structure and polymorphic transformations of Cu-S system compounds/ V International Scientific and Practical Conference «Modern science: actual problems», May 16-17, 2023, Manchester. UK. 66 p. pp. 56-60, 2023, ISBN 978-91-65423-19-0 DOI <https://doi.org/10.5281/zenodo.7950997>.
11. E. Roseboom, An investigation of the system Cu-S and some natural copper sulfides between 25 degrees and 700 degrees C, Geol, 61, №4, pp. 641-672, 1996.
12. Mehdiyeva A.M., Quliyeva S.V. Mathematical model for estimation the characteristics of the noise immunity. Journal of Physics: Conference Series, Volume 2094, Cybernetics and IT. 2022. Ser. 2094 032060.
13. Mehdiyeva A.M., Bakhtiyarov İ.N., Quliyeva S.V. Determination of bandwidth indicators of corporate multiservice networks Proceedings of the XII International Scientific and Practical Conference "Actual priorities of modern science, education and practice". Paris, France. March 29 – April 01, 2022, pp.801-807.
14. Mehdiyeva A.M., Aliyeva L.A., Quliyeva S.V. Development of model for calculating the noise immunity indicators of transmission system information. The 8th International Conference on Control and Optimization with Industrial Applications. 24-26 August, 2022. Baku, Azerbaijan. pp. 324-326.