

# A Dual-Band T-Slot Microstrip Patch Antenna for Sub-6GHz 5G Application

---

## ABSTRACT

This paper presents a proposed a Dual-Band T-Slot Microstrip Patch Antenna for sub-6GHz 5G application. The proposed antenna is designed to operate at two frequency bands of 5.923 GHz and 7.444 GHz respectively. The size and feed technique are determined by design formulas. The simulation results show a good return loss (reflection coefficient) of -33.696 dB and -18.464 dB respectively which is way below the benchmark of 10dB. The gain and VSWR results are 5.45dB and 1.049 at 5.933GHz; 4.158dB and 1.272 at 7.443GHz respectively. The designed antenna is a good candidate of 6GHz 5G antenna application.

*Keywords: Dual-Band, T-Slot, ROGERS Substrate, Microstrip Patch, sub-6GHz*

## 1. INTRODUCTION

The wireless mobile industry has advanced significantly in the last ten years. It has progressed from fourth generation (4G) LTE systems to the highest data rate of the fifth generation (5G). Many countries have 4G wireless communication systems in place. However, 4G does not solve some problems, such as high data rates, congested spectrum, and high energy consumption [1]. The frequency range used in 5G technology is 600 MHz to 86 GHz. 5G technology is divided into two bands. The first band uses 600MHz to 6 GHz for LTE applications, while the millimeter wave band ranges from 24 GHz to 86 GHz. Different patch antenna shapes are proposed to reduce patch antenna size, refers to the use of novel geometries for patch antennas in order to reduce their physical size while maintaining good electrical performance [2]. Various substrate materials, such as ROGERS, FR4, Duroid, and Homey Comb [3], are available for designing wide-band antennas. It is critical to select the proper substrate material when designing an antenna. The cost of an antenna is directly proportional to the permittivity of the substrate [4].

Due to their low profile, light weight, and ease of integration with other electronic components, microstrip antennas are widely used in modern wireless communication systems. The structure of a microstrip slot antenna is straightforward. It is made up of a microstrip feed that couples electromagnetic waves through the slot above and radiates them through the slot. When compared to a microstrip fed microstrip antenna, a microstrip fed microstrip antenna provides better isolation between the feed and the material under measurement. They have greater integration flexibility with other active and passive devices in a hybrid MIC and MMIC design [5]. A substrate with a low dielectric constant and a high thickness provides a wide bandwidth, better radiation, and higher gain. It has the potential to be used in 5G applications. T-slot microstrip antennas are a type of microstrip antenna in which the radiating patch has a slot or gap. According to [6], T-slot causes an unbalanced current distribution on the patch, which can improve the bandwidth and radiation characteristics of the antenna. With an ever-increasing demand for dependable wireless communication, the need for efficient electromagnetic spectrum use is increasing.

T-slot microstrip patch antennas for multi-band operation have been proposed and studied in recent years. For example, in order to achieve dual-band operation in the 2.4 GHz and 5.8 GHz frequency bands for wireless local area networks (WLANs), a T-shaped slot with a rectangular patch was introduced [7]. To achieve tri-band operation for Wi-Fi, Bluetooth, and 5G systems, [8] proposed a T-slot microstrip patch antenna with a fork-shaped feeding structure. For wireless communication, the authors proposed a dual-band T-shaped microstrip patch antenna in [9]. The antenna is designed to operate in two frequency bands: WLAN (2.4-2.484 GHz) and WiMAX (3.1-3.8 GHz). The T-shaped slot on the patch is used to achieve dual-band operation. The proposed antenna has good characteristics in terms of return loss, radiation pattern, and gain. The authors also compare the proposed antenna's performance to that of other antennas, demonstrating that their antenna outperforms in terms of bandwidth and gain. Its small size and straightforward design make it ideal for practical applications. [10] proposed a small dual-band T-slot microstrip patch antenna for WLAN and WiMAX applications. The antenna is built on an inexpensive FR-4 substrate with a dielectric constant of 4.4 and a thickness of 1.6 mm. To achieve dual-band operation, the patch includes a T-slot. The proposed antenna is 30 x 30 mm<sup>2</sup> in size and has two resonance frequencies of 2.4 GHz and 3.5 GHz, with bandwidths of 4.16% and 3.43%, respectively. According to the simulation results, the antenna has good impedance matching, stable radiation patterns, and reasonable gains in both bands. Because of its dual-band operation, compact size, and simple structure, the proposed antenna is suitable for WLAN and WiMAX applications.

We propose a T-slot microstrip patch antenna that operates at two frequency bands suitable for sub-6GHz 5G applications in this paper. The patch antenna's dual-band operation is accomplished by incorporating a T-shaped slot. The antenna's small size (44mm x 41mm) makes it suitable for a wide range of 5G applications, including smartphones, laptops, and IoT devices. The performance of the proposed antenna is evaluated in terms of return loss, radiation pattern, and antenna gain.

## 2. ANTENNA DESIGN

The proposed antenna is a dual-band T-slot microstrip patch antenna designed for 5G applications operating at sub-6GHz. The antenna was created with the help of Computer Simulation Technology (CST) Microwave Studio software, which is widely used in the industry for electromagnetic simulation and design. The proposed antenna geometry is designed on a ROGERS RO4450B substrate with a thickness of 1.6mm and a dielectric constant of 3.7, with resonant frequencies of 5.923GHz and 7.444GHz. The simulation setup entailed creating a 3D model of the antenna geometry and adjusting parameters such as substrate properties, feeding mechanism, and other design specifications.

To achieve dual-band resonance in a compact size, the T-slot structure was used, and the patch size was optimized to achieve the desired resonance frequencies. The T-shaped slot was designed to be 13 mm wide and half the length of the patch and ground plane, which were 44 mm and 41 mm, respectively. To optimize the design, various parameters were changed using the CST Microwave Studio software, and simulations were run to see how they affected the performance of the antenna. The width and length of the T-slot, the length and width of the patch, and the location of the feed point are among the parameters that have been optimized. The goal of the optimization process was to achieve a compact design with a wide bandwidth and high gain for both frequency bands.

### 2.1 Design Equations

The design equations are presented in the following steps to obtain the dimensions:  
The width of the microstrip patch antenna is given by

$$W = \frac{\lambda_0}{f_0 \sqrt{(\epsilon_r + 1)/2}} \quad (1)$$

Calculation for the effective dielectric constant  $\epsilon_{reff}$

$$\epsilon_{reff} = \frac{\epsilon_r + 1}{2} + \frac{\epsilon_r - 1}{2} \left(1 + \frac{12h}{W}\right)^{-1} \quad (2)$$

Calculation for the length extension  $\Delta L$

$$\frac{\Delta L}{h} = 0.142 \frac{(\epsilon_{reff} + 0.3) \left(\frac{W}{h} + 0.264\right)}{(\epsilon_{reff} - 0.259) \left(\frac{W}{h} + 0.9\right)} \quad (3)$$

Calculation for the Length of the Patch

$$L = \frac{c_0}{2f_r \sqrt{\epsilon_{reff}}} - 2\Delta L \quad (4)$$

Where the effective length of the patch  $L_{eff}$

$$L_{eff} = \frac{\lambda_0}{f_0 \sqrt{\epsilon_{reff}}} \quad (5)$$

Calculation for the Ground Dimensions

$$L_g = 6h + L \quad (6)$$

$$W_g = 6h + W \quad (7)$$

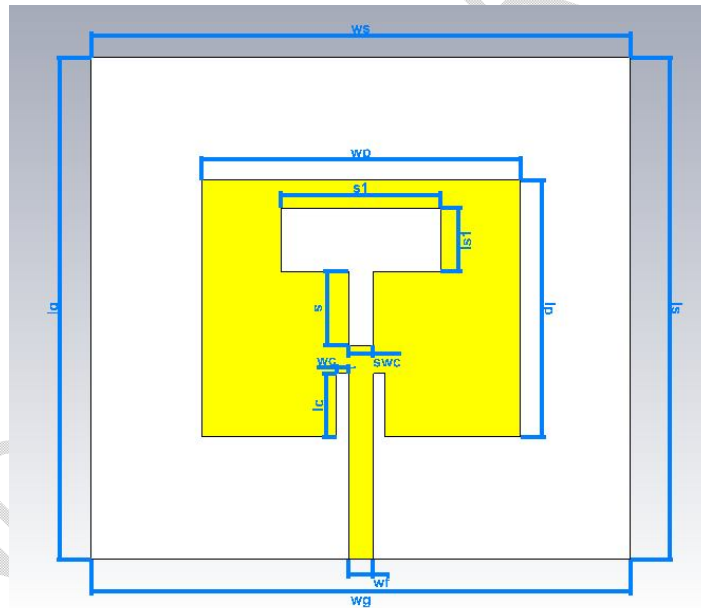
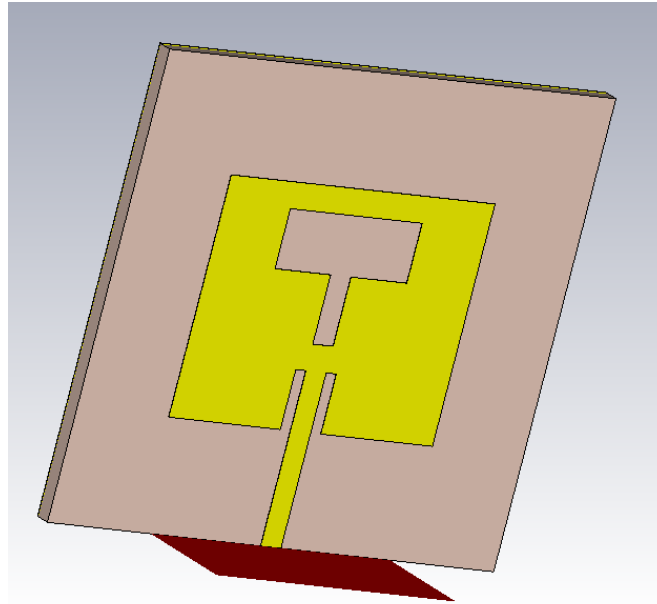

Fig. 1. Proposed Antenna Dimensions

Table 1. Simulation Parameters

S/N	Parameters	Description	Values
1	WP	Width of Patch	26 mm
2	LP	Length of Patch	21 mm
3	HP	Height of Patch	2 mm

4	WS	Width of Substrate	44 mm
5	LS	Length of Substrate	41 mm
6	HS	Height of Substrate	1.6 mm
7	WG	Width of Ground	60 mm
8	LG	Length of Ground	56 mm
9	WF	Width of Feed	6 mm
10	LF	Length of Feed	18 mm

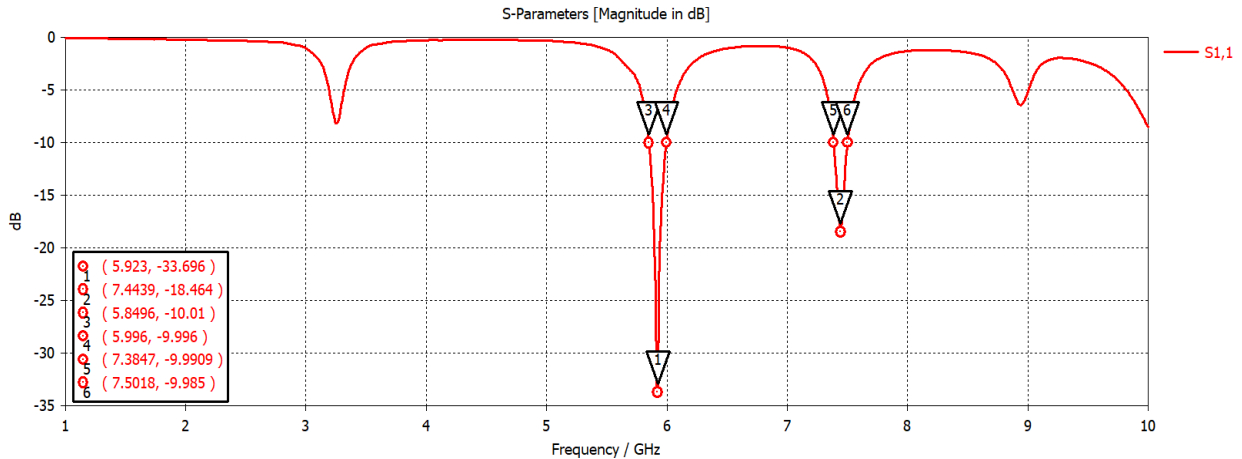

**Fig. 2. Proposed Antenna Perspective view**

### **3. RESULTS AND DISCUSSION**

#### **3.1 Return Loss**

Return loss is an important antenna parameter; it is the difference in dB between forward and reflected power. For the antenna to work efficiently, the return loss must be less than -10dB. Figure 4 depicts the proposed antenna's simulated return loss v/s frequency plot. At 5.923GHz, the proposed antenna had a return loss of -33.696dB and at 7.444GHz, it had a return loss of -18.464dB.



**Fig. 3. Return Loss (S11-parameters)**

### 3.2 VSWR

The VSWR is an impedance mismatch measurement between the feed line and the antenna. The mismatch raises the VSWR value. For perfect impedance matching, the minimum VSWR is one and the maximum VSWR is two. Figure depicts the proposed antenna's simulated VSWR v/s frequency plot. The proposed antenna has a VSWR value of 1.20 at 5.44GHz and a VSWR value of less than 2 for the frequency range of 3.89 to 6.80GHz.

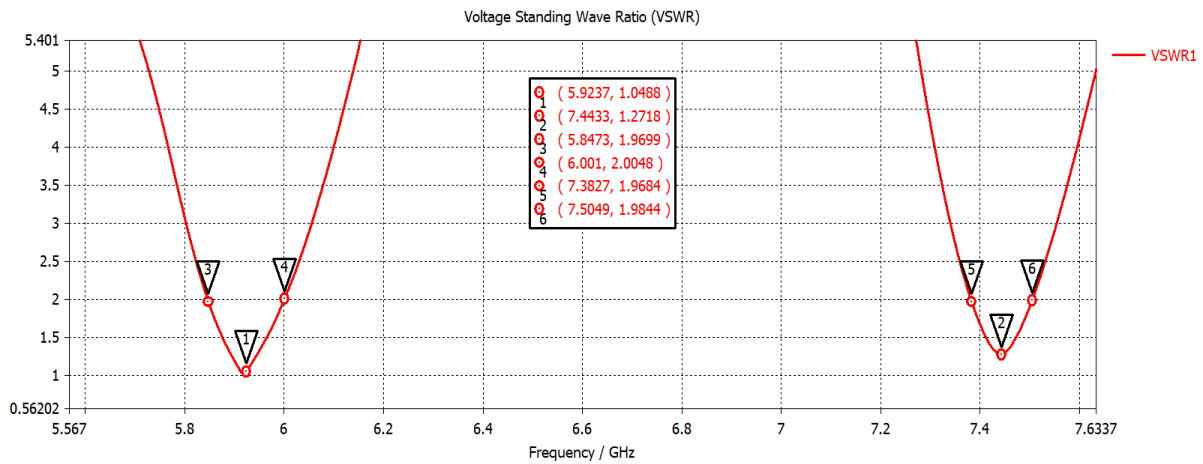

**Fig. 4. VSWR**

### 3.3 Gain

The gain of an antenna describes its efficiency and directional capabilities. For the antenna to function properly, the gain value should be greater than 3dB. The gain of the proposed antenna is 5.45dB at 5.933GHz and 4.158dB at 7.443GHz. Figure xx depicts the gain plot of the proposed antenna.

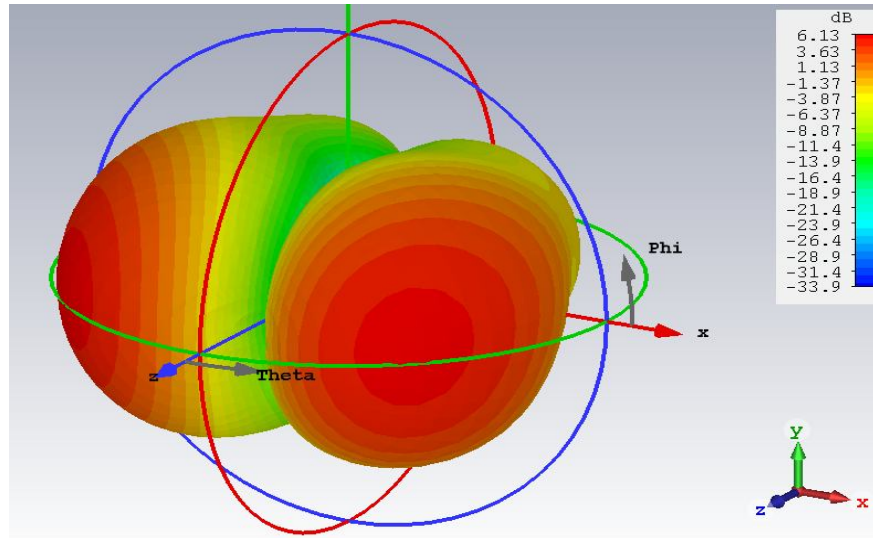

Fig. 5. Antenna Gain at 5.923GHz

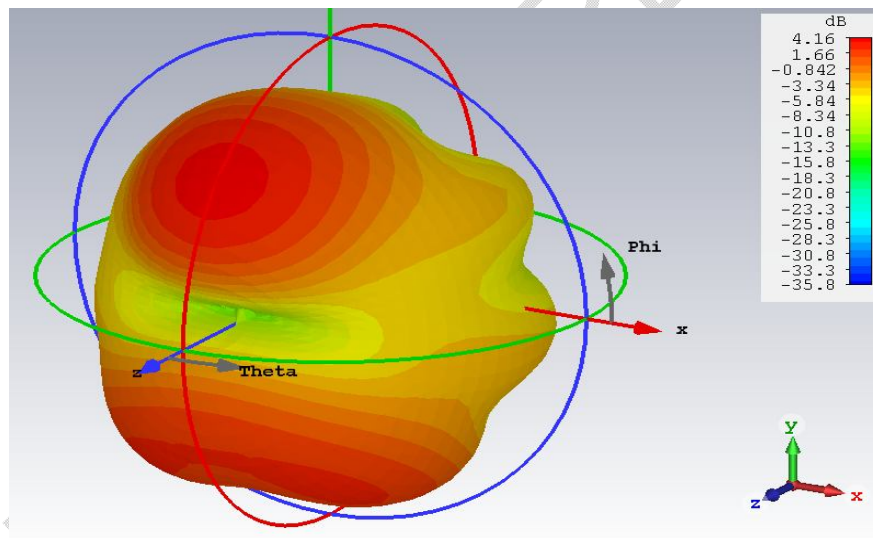

Fig. 6. Antenna Gain at 7.449GHz

#### 4.0. CONCLUSION

This paper describes the design of a T-shape slot antenna for wireless communication and analyzes its various parameters. The antenna is built on a ROGERS RO4450B substrate, and it is excited by a microstrip line feed. The results show that the return loss of the designed antenna is at -33.696 dB and -18.464 dB respectively which is less than the threshold value of -10 dB indicating that the losses are minimal during transmission. The antenna has a good gain of 6.131 dB, especially at 5.923 GHz. The designed antenna can be used for a variety of wireless applications, including WLAN and 5G communication.

## REFERENCES

1. Wang, C. X., Haider, F., Gao, X., You, X. H., Yang, Y., Yuan, D., Aggoune, H., Haas, H., Fletcher, S., & Hepsaydir, E. (2014). Cellular architecture and key technologies for 5G wireless communication networks. *IEEE Communications Magazine*, 52(2), 22- 130.
2. Agrawal, S. S., & Dubey, S. K. (2013). A Fractal Circular Patch Antenna for Multiband Wireless Applications" *IEEE Transactions on Antennas and Propagation*, 61(8), 4139-4143.
3. Alisha S., & Sachin, K. (2020). Design of Star Shaped Antenna. *8th International Conference on Reliability, Infocom Technologies and Optimization (Trends and Future Directions) (ICRITO)*.
4. Zhou, L., Rodrigues, J. J. P. C., Wang, H., Martini, M., & Leung, V. C. M. (2018). 5G Multimedia Communications: Theory, Technology, and Application. *IEEE computer society Guest editorial*.
5. Outerelo, D. A., Alejos, A. V., Sanchez, M. G., & Isasa, M. V. (2015). Microstrip Antenna for 5G Broadband Communications: Overview of Design Issues. *IEEE International Symposium on Antennas and Propagation & USNC/URSI National Radio Science Meeting*.
6. Ali, M. S. M., Islam, M. T., Misran, N., & Mandeep, J. S. (2013). A Review on T-Slot Microstrip Antennas. *Progress in Electromagnetics Research B*, 47, 205-231.
7. Abbosh, A. M. (2014). Dual-band T-shaped slot antenna for WLAN/WiMAX applications. *Progress In Electromagnetics Research C*, 47, 1-8.
8. Zhu, X., Xie, Z., & Liu, Y. (2019). Tri-band T-slot microstrip patch antenna for WLAN and Bluetooth. *Microwave and Optical Technology Letters*, 61(6), 1536-1540.
9. Sahoo, S., Dwari, S., & Behera, S. K. (2018). A dual-band T-shaped microstrip patch antenna for wireless communication. *International Journal of Microwave and Optical Technology*, 13(1), 68-72.
10. Hoque, M. A., & Islam, M. T. (2016). Design and simulation of a dual-band T-slot microstrip patch antenna for WLAN and WiMAX applications. *International Journal of Microwave and Optical Technology*, 11(3), 203-208.