

Method Article

Research on formwork construction technology of railway bridge

ABSTRACT

With the continuous development of railway bridge construction, the application of new technology, new technology and new materials is becoming more and more extensive, which puts forward higher requirements for the design and construction of formwork. In this paper, the railway bridge formwork is taken as the research object. In view of the technical problems in the construction of the short-line method segmental prefabricated bridge formwork, combined with the current Zhengzhou-Xuchang urban railway viaduct project under construction, the type of formwork, the design and construction technology of formwork are introduced. Combined with engineering examples, the characteristics of formwork design and construction are explained, which provides a theoretical basis for the design and construction of bridge formwork.

Keywords: Railway bridge; segmental prefabrication; template design; formwork construction

1. INTRODUCTION

With the development of China's economy, the development speed of China's bridge construction field has also been greatly improved. Various new processes, new materials and new technologies have been continuously proposed and applied in bridge engineering, which greatly improves the construction difficulty of bridge engineering. With the improvement of construction difficulty, the quality of bridge construction has also been improved^[1]. In bridge construction, formwork technology has been greatly developed and improved, and bridge formwork plays an important role. The design, manufacture and installation of the formwork are closely related to the construction quality. Only when all aspects of the formwork are well done, the quality of the bridge can be guaranteed^[2]. If there are problems in the design, manufacture and installation of the formwork, it will bring great hidden dangers and losses to the bridge, which will adversely affect the durability of the bridge^[3]. With the continuous improvement of construction technology, a new way of formwork production has been opened up through hydraulic technology, and the concept of 'steel instead of wood' has emerged. Bridge workers have developed combined steel formwork and large steel formwork, improved the construction technology of bridge formwork, and promoted the improvement of social and economic benefits^[4].

At present, the beam formwork of bridges in China is mostly assembled. The advantages of assembled formwork are convenient design and manufacture, and low cost^[5]. However, there are also many shortcomings, such as time-consuming and labor-intensive assembly and disassembly. When dismantling the formwork, it is difficult to dismantle due to the limitation of the internal space of the segmental beam, and the internal mold handling is also difficult due to the small cavity of the end partition wall. The stiffness of assembled formwork is small and easy to deform, and the quality of precast beam is difficult to guarantee^[6]. In order to improve the speed of beam making, reduce labor intensity, improve the degree of mechanization and engineering quality, the integral steel formwork is gradually popularized in the construction of precast beams. The scattered internal mold has the disadvantages of

many mold plates, small stiffness, easy deformation, large assembly and disassembly workload, and long working cycle. It is of great significance to speed up the precast speed of box girder and ensure the quality of box girder by using full hydraulic integral steel formwork^[7]. The full hydraulic integral steel formwork consists of bottom formwork, outer formwork, hydraulic inner formwork system and end formwork. The surface finish of the beam made of this template is good, which can ensure the dimensional accuracy of the beam. Moreover, it has enough strength, stiffness and stability to ensure the correct size of each part in the construction process. In addition, repeated use will not affect the shape of the beam^[8].

2. BRIDGE TEMPLATE CONSTRUCTION TECHNOLOGY OVERVIEW

At present, the bridge formwork construction technology has entered a new era. With the in-depth study of bridge formwork structure design, system research and manufacturing process, there have been three forms of formwork engineering, such as combined, permanent and instrumental^[9]. Nowadays, China has divided the bridge formwork into several major systems through research, including composite steel formwork, large formwork, sliding formwork, climbing formwork, self-elevating and turning formwork, cantilever casting hanging basket formwork, highway small box girder and T-beam formwork^[10]. Among them, the composite steel formwork system is mainly composed of composite steel formwork and its accessories. It has simple structure, convenient disassembly and assembly, and good surface flatness after disassembly, which is conducive to on-site civilized construction and safe production. The system is suitable for the auxiliary structure, floor and foundation construction of general bridges. It is convenient for manual operation, flexible assembly and strong versatility^[11].

Compared with the composite steel formwork system, the segmental precast formwork system has the advantages of high overall stiffness, good surface quality of concrete forming and high construction efficiency^[12]. In recent years, the sliding formwork system has been widely used. It can effectively improve the construction efficiency of the pier, save a lot of construction materials and manpower, effectively improve the overall cost of the project, and bring higher economic benefits to the enterprise^[13]. In addition, the sliding formwork system also has good construction quality and construction civilization. The integral formwork hydraulic climbing formwork is a new construction technology which combines sliding mode and traditional formwork technology. The process adopts the internal and external wall formwork to climb up as a whole at the same time. When construction needs, it can also climb up in sections and sections. Hydraulic internal model system consists of template system, frame system and hydraulic system^[14]. Among them, the formwork system includes four parts, the lower formwork of the side formwork, the middle formwork, the edge formwork and the top formwork. The variable cross-section and the orifice section adopt large composite steel formwork. The frame system includes frame truss, running support bracket and other parts^[15].

3. PROJECT OVERVIEW

Zhengzhou-Xuzhou Intercity Railway is an inter-city railway connecting Zhengzhou and Xuchang, which reduces the commuting passenger flow between cities and towns and relieves the traffic pressure. It is of great significance to promote regional development and improve the railway network system. The total length of Zhengzhou-Xuzhou Railway is 67.13km, of which Zhengzhou section is 33.43km and Xuchang section is 33.78km. The viaduct section of Xuchang section occupies 27.57km. In order to ensure the quality and construction progress of the project, the viaduct section mainly adopts the segmental prefabricated assembly bridge of short-line method. There are a total of 736 beam sections and 8640 segmental beams in the bridge with segmental precast assembly technology. The bridge section form is shown in Figure 1. When dividing the segment, the beam end segment is at both ends of the span, the transition segment is adjacent to the beam end segment, and the rest is the standard segment. The length of the beam end section is 2.45m, the length of the transition section and the standard section is 2.5m, the width of the

top surface of the section is 10.6m, the width of the bottom surface is 4.4m, the height of the beam is 1.8m, and the center distance of the transverse bridge to the bearing is 3.6m. The thickness of the roof of the segment beam end is 40cm, the thickness of the web and the bottom plate is 60cm, the thickness of the roof of the transition segment and the standard segment is 25cm, the thickness of the web is 36cm, and the thickness of the bottom plate is 28cm. The bridge is poured with C50 concrete. The weight of the beam end section is 49.4t, the weight of the transition section is 40.5t, and the weight of the standard section is 37.8t. In order to reduce the stress concentration, the key teeth are in the form of multiple keys.

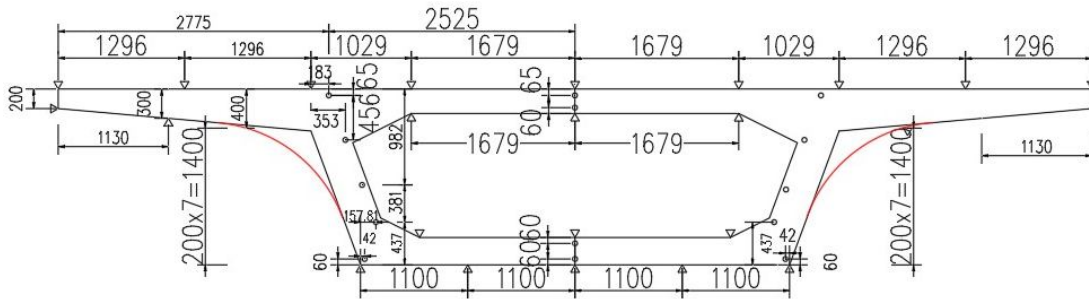

Fig.1 Standard segment cross section (unit : mm)

4. BRIDGE TEMPLATE STRUCTURE

According to the installation sequence, the formwork system includes fixed end mold, movable end mold, side mold, bottom mold and internal mold^[16] (Including standard section, transition section and end section). The internal mold can be telescopic, through the hydraulic lifting and contraction cylinder. The driving uses a hydraulic motor to drive the bottom mold trolley. The adjustment of the bottom mold elevation is realized by a horizontal cylinder and a jacking cylinder. The bottom mold trolley is driven by a hydraulic motor. The shrinkage of the side die is realized by the shrink cylinder, and the translation of the side die is realized by the hydraulic pushing cylinder.

4.1 End mould

The end formwork of the bridge includes fixed end formwork and movable end formwork. The fixed end mold is made of a panel, which is stiffened and connected to a support anchor bracket fixed to the ground, as shown in Figure 2. The bracket is composed of steel and channel steel, and is welded and fixed with the embedded parts embedded on the base of the pedestal. There are shear keys on the fixed end formwork. Due to the different positions of the precast beam sections, the number of shear keys will also be different. In the whole template system, the precision of the fixed end mold is the highest. When installing the fixed end formwork, it is necessary to ensure that the die surface of the end formwork is perpendicular to the central axis of the beam section to be poured and is kept vertical. The upper flange of the die should be elevation tested to ensure its levelness. The end die support must be firm, and the template itself has sufficient stiffness. The movable end formwork is mainly used for the initial beam end and the last section pouring. The movable end mold is made of a panel and is fixed to the side mold after stiffening, as shown in Figure 3.

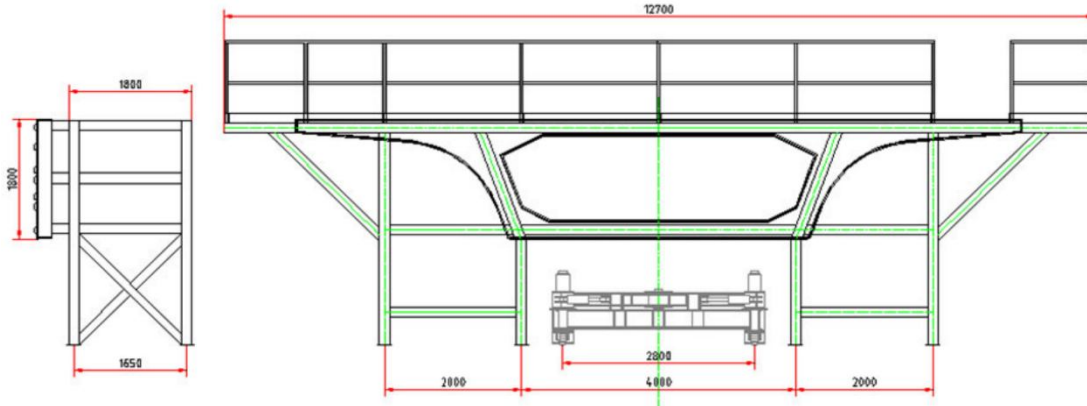

Fig.2 Fixed-end template diagram

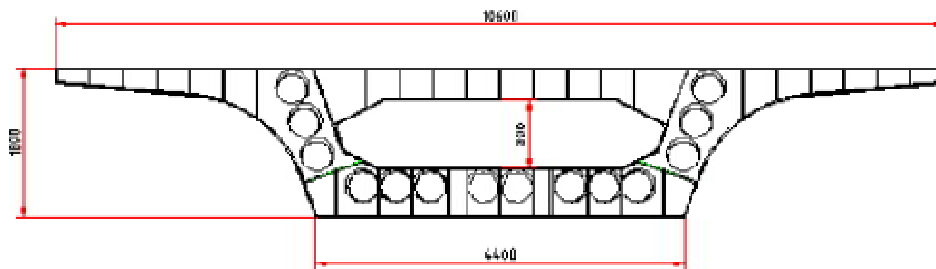

Fig.3 Activity end module diagram

4.2. Bottom mold and bottom mold car

The bottom formwork panel adopts thick steel plate, the back rib adopts channel steel, and the stiffener is set horizontally and vertically. The leg is composed of square steel, square steel and channel steel. Four hydraulic cylinders are installed vertically and horizontally, which can be used for three-dimensional position adjustment of the bottom die and the matching beam section. The walking of bottom die trolley is completed by hydraulic motor. When the segmental beam is prefabricated, the positioning of the matching beam is adjusted by the forward and backward movement of the bottom die trolley. When the matching beam is coarsely adjusted, the adjustment distance is large and is not affected ; when doing fine adjustment, the adjustment distance is millimeter level, and the walking button of the moving trolley needs to be clicked back and forth. Because the trolley is completed by the hydraulic system, it is difficult to install the brake device on the tire of the trolley, so it can only be adjusted by clicking the walking button to achieve position positioning. The operation is relatively time-consuming, and a little inattention will collide with the template, which is easy to cause template deformation. When the matching beam is coarsely adjusted, the hydraulic system is used to complete the walking ; when doing fine adjustment, an oblique screw screw is installed at the rear of the bottom die trolley. One end is equipped with movable plugs, and the other end is equipped with rail clamps and installed on the track. By adjusting the rotating screw for fine adjustment, the linear monitoring and measurement efficiency is accelerated, the working time is reduced, the collision between the segment beam and the template is avoided, and the segment beam matching is completed with high efficiency and high quality.

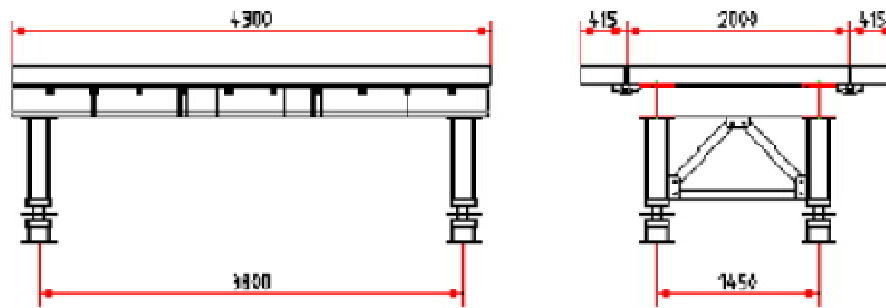

Fig.4 Bottom mold template diagram

4.3. Side modes

The side formwork is made of high-quality steel plate, the back rib is channel steel, the support is channel steel, the bottom bracket is composed of steel, and the support is composed of steel, as shown in figure 5. The support is equipped with a hydraulic cylinder and a screw adjustment system, which can be adjusted horizontally and vertically. The bracket is welded and fixed with the embedded parts embedded in the foundation. The side die is moved and adjusted by the screw adjustment device on the support of the bracket. After the adjustment is completed, it is reliably connected with the prefabricated seat plate by the finishing rolling thread steel bar. In the installation process, it is necessary to pay attention to the machining accuracy of the joint between the side die and the bottom arc section and the straight section to ensure smooth transition and tight joints. In addition, the joint between the side formwork and the fixed end formwork and the matching beam also needs to be strict, and the slurry stopping device should be set between the joint and the matching beam.

The oblique leg of the side die adds a hydraulic system and movable plugs. When the side mold needs to be adjusted, the movable plug can be pulled out, the hydraulic system can be opened and the lifting or contraction action can be performed. When lifting or shrinking to a certain position, the original screw screw can be used for fine-tuning until the adjustment is completed. The hydraulic system and movable plug can improve the adjustment speed of the template and reduce the utilization rate of the screw. This can save the time of adjusting the template, reduce the utilization rate of the screw, and effectively increase the service life of the template. In addition, the activity plug can also reduce the workload of workers and improve work efficiency.

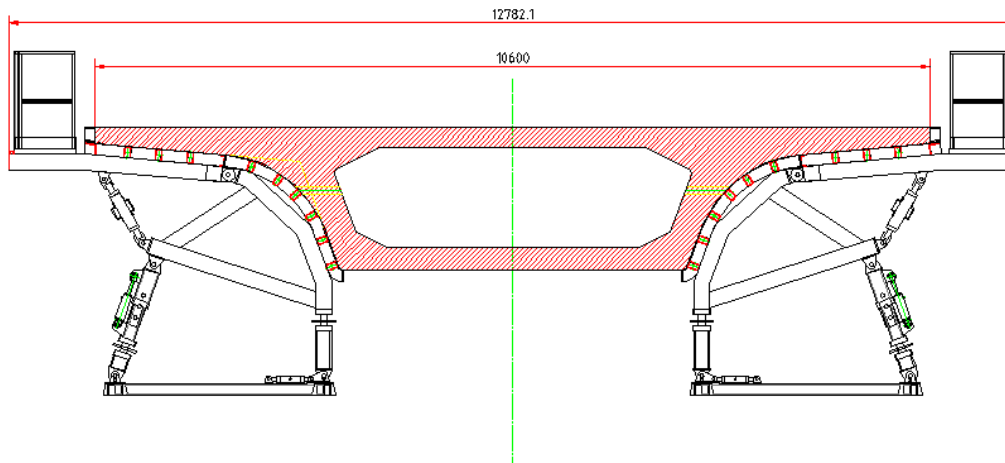

Fig.5 Side template diagram

4.4 Internal model

The segmental beam is composed of three segments : end formwork segment, transition segment and standard segment, and the cavity form of each segment is different. The size of the beam end cavity gradually evolved from the end-mold segment and the transition segment to the standard segment section form. The standard segment internal formwork panel is made of steel plate, the standard segment roof transverse rib is composed of I-beam, and the internal formwork support is composed of I-beam. The standard segment internal model uses a hydraulic cylinder for expansion and extension, and a hydraulic cylinder is also set at the head of the internal model and the tail of the internal model support for jacking. The orientation of the standard segment is from the fixed end mode to the matching segment.

The prefabricated direction of the beam is prefabricated from one end of the beam to the other end. The positioning direction of the internal mold is from the fixed end to the matching end, but when prefabricated to the last two segments, the transition segment and the end mold segment, the internal box section size of the two segments from the fixed end to the matching end is from small to large, and the change range is large, so the internal mold cannot be positioned from the fixed end to the matching end. At this time, the internal model can only walk from the matching end to the fixed end, which is a problem to be considered when designing the template.

5. TEMPLATE DESIGN

5.1 Template design principles and basis

The template design should follow the general principle of meeting the process, simple structure, safe and reliable, convenient construction, economical and reasonable^[17]. The internal mold should meet the needs of the longitudinal and transverse sections of the inner cavity of the segmental beam, adopt the hydraulic automatic scaling structure, adapt to the changing section structure requirements, and can be installed and removed at one time. In order to improve production efficiency, the contraction and expansion of the internal mold must be fast and safe. The internal mold should be able to cooperate with the rapid pouring of concrete, without deformation due to the use of external vibration, and without displacement greater than the design error due to the lateral pressure and buoyancy generated by concrete pouring. The template should have sufficient strength, stiffness and stability, and the structure should be able to adapt to repeated use without deformation. The plate surface should be easily cleaned quickly and reused in a short time.

The design of the formwork is based on the structural form, design span, construction organization design, load size, foundation soil type and related design and construction specifications^[18]. When designing the formwork, it is necessary to calculate according to the following loads : the vertical load includes the gravity of the formwork itself, the gravity of the newly poured concrete, the gravity of the construction personnel and the equipment, the gravity of the steel bar and the load generated when vibrating the concrete ; the horizontal load includes the lateral pressure of the newly poured concrete on the formwork and the horizontal load caused by vibration when pouring into the concrete. When calculating the strength and stability of formwork, bracket, etc., the wind force acting on it should be considered. When designing the formwork of prestressed concrete members, it is necessary to consider the interaction between the prestressed members and the formwork and the support, such as the elastic compression, creep, arching of the beam and the displacement of the bearing bolts or embedded parts. In the design of formwork assembly, in addition to various loads, the lifting and dismantling loads after assembly should be considered, and the fulcrum and lifting point position should be indicated. The lifting ring must be determined by calculation.

5.2.Template installation and removal

Firstly, the bottom die is installed and placed on the prefabricated strip pedestal, then the bottom die is lifted to the strip pedestal for leveling, and the flatness of the bottom die is measured and qualified. Then the outer mold can be installed. When installing the outer mold, the trolley is placed in a predetermined position, and the screw jack is placed. The adjusted side mold is lifted to the design position by the door machine, and the connecting bolt between the bottom mold and the side mold is worn. According to this process, all side dies are assembled. After ensuring that the outer mold alignment is consistent with the beam alignment through measurement, the internal mold trolley is placed on the internal mold pre-assembled pedestal in order. Then the roof is lifted to the keel beam of the internal mold trolley, and the hydraulic system is installed according to the design. When installing the end die, the end die is first assembled on the ground, and then the whole is hoisted to the assembled outer die and the bottom die by the gantry bridge erecting machine, and the end die and the side die are connected by bolts. After installing one end die, install the other end. The position of the fixed end die is fixed. Each time the template is installed, it is only necessary to measure and check its plane position, horizontality and verticality. After the end mold, bottom mold and side mold are adjusted in place, the gantry crane is hoisted into the steel skeleton and positioned. The internal mold trolley is used to move the internal mold into the inner cavity of the steel skeleton, and the internal mold is expanded by the hydraulic system installed on the sliding beam to form the prefabricated internal mold of the box girder, and then the adjustable support rod is adjusted to support and fix the internal mold.

The segmental beam must be demoulded after the concrete compressive strength reaches 75%, and must wait until the concrete strength reaches 90% of the design strength before moving. The order of removing the formwork is as follows: first remove the internal formwork, then remove the external formwork, then move the matching beam section to the position of the new casting beam section, and finally move the new casting beam section to the position of the matching beam. After the matching beam completes the matching function, the test block of the same condition needs to be tested. When the concrete strength reaches 90 % of the design strength, it can be lifted. In the process of moving the beam, the bottom die car must not be evacuated, and can only be evacuated after lifting. After lifting the matching beam section, the bottom formwork trolley is moved to the new casting beam section, and the new casting beam section is moved to the matching beam position according to the way of removing the matching beam, which is used as the prefabricated matching beam of the next beam section. After removing the template assembly, it must be cleaned immediately and smeared with special release agent, and then lifted to the template yard for classification and neat stacking to reduce the deformation during the template stacking.

6. CONCLUSION

In a word, bridge formwork construction is very important in the whole bridge construction, which directly affects the overall quality, progress and cost of bridge construction. In bridge construction, formwork engineering is an important part of reinforced concrete engineering and an important guarantee for ensuring concrete quality. At the same time, the template project is also a link that must be strictly implemented in safety production. The formwork project directly determines the appearance and internal quality of the bridge project. Therefore, in the construction of the bridge template project, only the good template and the advanced and reliable installation process can complete the high-quality bridge project. With the development of formwork engineering, the formwork has developed to a more advanced level, but there is still much room for development, which requires us to continuously study new processes and methods.

REFERENCES

- [1] Zhang Liqing. Summary of bridge construction technology by segmental precast assembly method[J]. Railway standard design, 2014,58(12): 63-66.
- [2] Sun Dong. Quality control of bridge construction formwork[J]. Northern Traffic, 2012,35(6): 142-144.
- [3] Zhang Likun. Application research on bridge formwork construction technology[J]. China Standardization, 2018,61(10): 140-141.
- [4] Yang Sheng and YANG Wei. Research on key technology control of short-term segmental precast assembly of urban bridges[J]. Chinese and foreign highways, 2019,39(4): 89-96.
- [5] Wei Ming. Study on the applicable conditions and some key technologies of segmental precast assembled bridges[D]. [Master's degree thesis]. Nanjing: Southeast University, 2016.
- [6] Geng Zhibing. Application of integral hydraulic walking formwork in box girder prefabrication[J]. Heilongjiang Transportation Science and Technology, 2019,42(3): 109-111.
- [7] Wang Guidong, Cheng Xingfeng, Li Lei. 70 m precast box girder full hydraulic formwork construction technology[J]. Railway construction technology, 2006,44(2): 41-43.
- [8] Shi Zhengxin. Research on the application of bridge formwork construction technology[J]. Engineering construction and design, 2020,68(2): 152-153.
- [9] Podolny W. An overview of precast prestressed segmental bridges[J]. PCI Journal, 1979, 24(1): 56-87.
- [10] Peng P, Wang B Q. Simulation analysis of construction of main girder of Bali Lake Bridge[J]. Bridge Construction, 2013, 43(2): 76-80.
- [11] Brockmann C, Ing. D, Rogenhofer H. Bang Na Expressway, Bangkok, Thailand - world's longest bridge and largest precasting operation[J]. PCI Journal, 2000, 45(1): 26-39.
- [12] Mendorf P E. Design-construction of precast segmental elevated metro line for Monterrey, Nuevo, Mexico[J]. Pci Journal, 1993, 38(2): 42-56.
- [13] Russell. H, Ralls M, Tang B. Part 3: Concrete Bridges: Prefabricated bridge elements and systems in Japan and Europe[J]. Transportation Research Record Journal of the Transportation Research Board, 2005, 78(8): 101-109.
- [14] Podolny W, Jr, Muller J M. Construction and design of prestressed concrete segmental bridges [M]. Wiley, 1982.
- [15] Brockmann C, Ing. D, Rogenhofer H. Bang Na Expressway, Bangkok, Thailand - world's longest bridge and largest precasting operation[J]. PCI Journal, 2000, 45(1): 26-39.
- [16] Palmer A M. Fundamentals of launching a precast concrete segmental operation for bridge construction projects[J]. PCI Journal, 2006, 51(3): 32-44.

[17] Dai X H, Wu X F, Zhang T K. Research on the precision control technology of short-line segmental prefabricated assembly bridge[J]. IOP Conference Series: Earth and Environmental Science, 2018, 128(1): 1-6.

[18] Russell H, Ralls M, Tang B. Part 3: Concrete Bridges: Prefabricated Bridge Elements and Systems in Japan and Europe[J]. Transportation Research Record Journal of the Transportation Research Board, 2005,1928:101-109.

UNDER PEER REVIEW