

Comparison of organic fertilizers on the optimization of growth and yield parameters of lettuce (*Lactuca sativa* L.) in the city of Daloa

ABSTRACT

The objective of the study was to evaluate the fertilizing potential of two plants available in the locality, namely *Tithonia diversifolia* and *Thevetia neriifolia*, on the growth and yield parameters of lettuce (*Lactuca sativa* L.). The device applied was in Fisher blocks, completely randomized with four treatments and four repetitions. The treatments applied significantly influenced the results obtained on all the growth and yield parameters considered. The liquid treatments (*Tithonia* and *Thevetia*) gave the best results on the height, number of leaves, leaf width, leaf length and wingspan of lettuce plants. Yield was better with treatments based on *Tithonia diversifolia*, both fresh and The use of *Tithonia diversifolia* and *Thevetia neriifolia* in lettuce cultivation could constitute an alternative to the decline in fertility soils of vegetable plots due to their overexploitation in urban areas.

Keywords: Market gardening; *Lactuca sativa*; biofertilizers; *Tithonia diversifolia*; Yield.

1. INTRODUCTION

The number of people living on the planet is expected to grow by 2 billion by 2050, from 7.7 to 9.7 billion. This global population is expected to become increasingly urban [10]. However, the practice of urban and peri-urban agriculture, especially market gardening in Africa, involves increasingly reduced spaces due to strong demographic pressure and the growing demand for building land [2]. The consequence of this pressure is the degradation of market garden soils leading to their decline in fertility and productivity [4]. The use of chemical fertilizers, due to their immediate action on crop productivity, has been considered as one of the solutions to compensate for the loss of fertilizing elements removed by harvests [1].

However, the high cost of these chemical fertilizers makes them almost inaccessible to small farmers [13]. In addition, the long-term effects of these chemical fertilizers on the quality of the environment are detrimental [6]. To this end, it seems interesting to promote the use of organic fertilizers in order to sustainably intensify market gardening. Indeed, these organic fertilizers are less expensive, easily accessible and less dangerous for the environment. Among these organic fertilizers, amendments based on *Tithonia diversifolia* [9] and *Thevetia neriifolia* offer new prospects for reversing the trend of a significant decline in the fertility of market garden soils and the excessive use of chemical fertilizers.

While many studies have been carried out on the use of *Tithonia diversifolia* in soil fertilization for certain crops, the same is not true for *Thevetia neriifolia*. However, these two plants have been little or almost not valued as fertilizer in agriculture in Côte d'Ivoire [11]. In addition, they are abundant in the locality of the study, especially in the rainy season for *Tithonia diversifolia* and in all seasons even for *Thevetia neriifolia*. This study was undertaken in order to valorize waste from clearing and pruning of living hedges, which are

respectively *Tithonia diversifolia* and *Thevetia neriifolia*, in order to improve the fertility of market garden soils. These plant materials are available in the locality of Daloa.

2. MATERIAL AND METHODS

2.1 Material

2.1.1 Experimental environment

The trial was conducted on an experimental plot located on the site of the Jean Lorougnon Guédé University (UJLoG) in Daloa. Daloa is a city in the center-west of Côte d'Ivoire. It is the capital of the Haut-Sassandra department and region (Figure 1), located 141 km from Yamoussoukro (political capital of the country) and 383 km from Abidjan (economic capital). The department of Daloa is bordered to the north by that of Vavoua, to the south by that of Issia, to the east by that of Zuénoula and Bouaflé and to the west by the department of Duékoué [3].

The vegetation of the area was originally dense semi-deciduous forest. The soils are ferralitic. They have good agricultural aptitudes for all types of crops [14]. The climate, of the humid tropical type, has four seasons: a long rainy season with stormy inter-seasons (April to mid-July), a short dry season (mid-July to mid-September), a short rainy season (mid-September to November) and a long dry season from December to March (Ouattara, 2018).

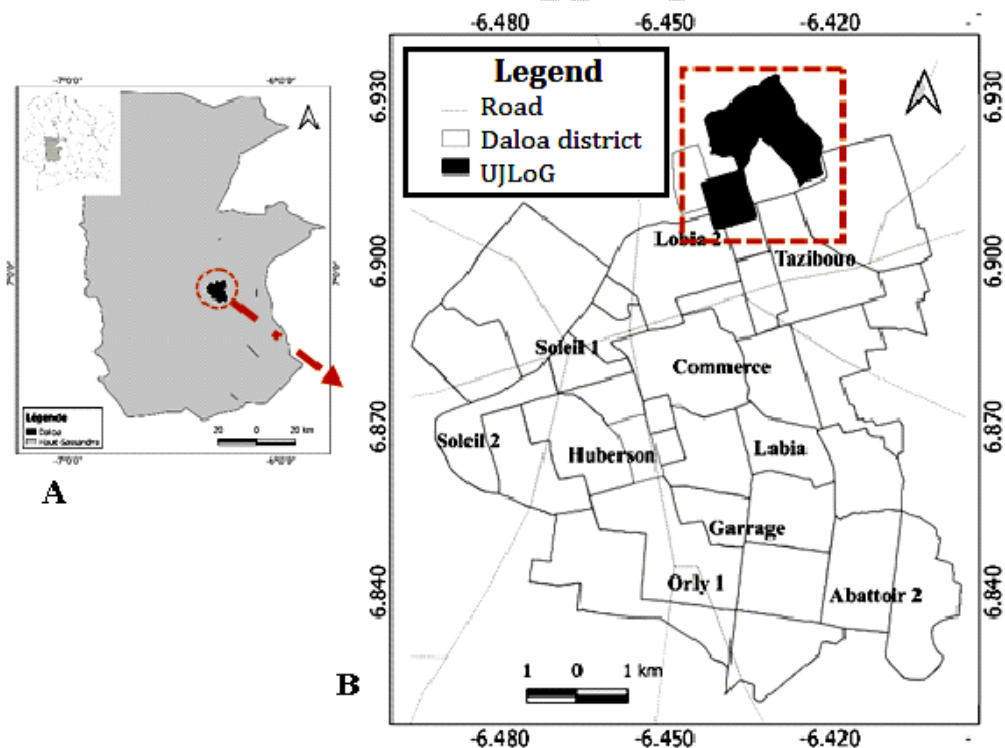

Figure 1. Location of the study area and site (A: Haut-Sassandra region; B: City of Daloa)

2.1.2 Plant material

Lettuce plants from industrial variety seeds (Specify the commercial name of the variety) purchased commercially and aged 4 weeks after sowing constituted the speculation which was used to test the fertilizers produced.

2.1.3 Fertilizing material

The fertilizers were obtained from the leaves of *Tithonia diversifolia* and *Thevetia neriifolia* (Figure 2).

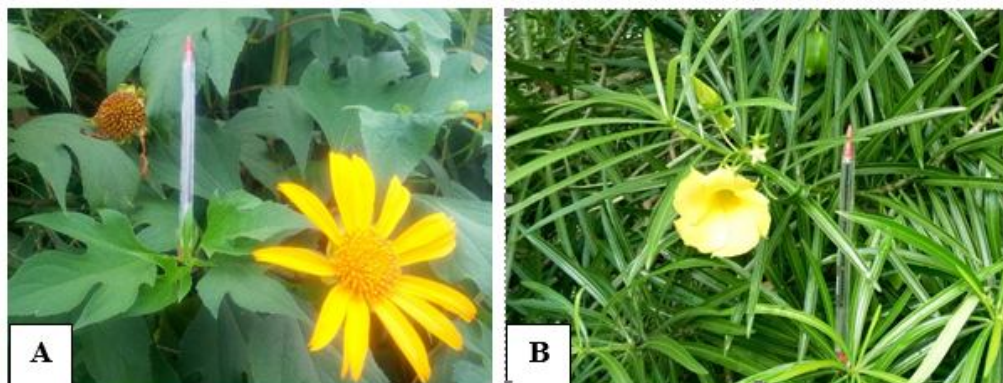

Figure 2. Leafy and flowering branches of *Tithonia diversifolia* (A) and *Thevetia neriifolia* (B)

The leaves of *Tithonia diversifolia* have been used in two forms: liquid (slurry) and solid (fresh chopped leaves). Those of *Thevetia neriifolia* were used in a single form: liquid (slurry):

- For the preparation of fresh Tithonia, the fresh leaves of *Tithonia diversifolia* were harvested then chopped into a thin strip and incorporated directly into the soil of the beds concerned by this treatment.
- The production of liquid Tithonia first consisted of harvesting the fresh leaves of *Tithonia diversifolia*, then cutting them up (chopping). The chopped leaves were then put in a container due to 1 kg per 10 liters of water. The mixture was closed and left to decompose for ten days protected from light.
- The preparation of liquid Thevetia (slurry) from the leaves of *Thevetia neriifolia* followed the same process as that of liquid Tithonia.

2.2 Methods

2.1.1 Establishment

Before transplanting, the lettuce seeds remained for four (4) weeks in the nursery. Seedlings with 3 to 5 well-opened and vigorous leaves were picked and transplanted on beds for 6 to 8 weeks. The transplanting due to 24 plants per bed was carried out in the evening. At the end of transplanting, the transplanted plants were suitably watered before transplanting.

The contribution of organic fertilizers was made before and after transplanting the seedlings according to the experimental device in blocks of Fisher.

2.1.2 Experimental apparatus

A completely randomized Fisher block device with 4 treatments and 4 repetitions (i.e. 16 boards) was used (Figure 3). The treatments applied are presented as follows:

- W0 : control treatment (without adding fertilizer to the soil);
- FTd: contribution to the soil of fresh chopped leaves of *Tithonia diversifolia*;
- TdL: supply of liquid manure based on *Tithonia diversifolia* leaves;
- TnL: supply of liquid manure based on *Thevetia nerifolia* leaves.

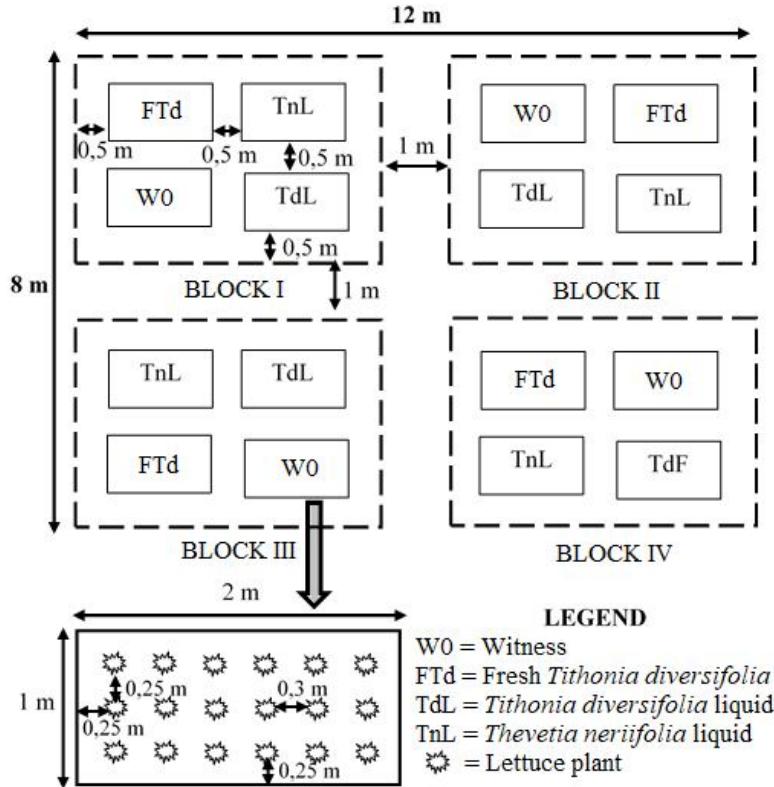

Figure 3. Experimental device

2.1.3 Cultivation maintenance

Each biofertilizer was added three times during lettuce cultivation. The first additions were made one week before transplanting in basal fertilization. The other two contributions were made as a cover after transplanting. The quantities and periods of application of fertilizers to crops are recorded in Table 1 below.

Table 1. Fertilization program and quantity of biofertilizers provided per treatment

| Treatments | Contribution of biofertilizers | | |
|-----------------------|--------------------------------|-----------------------------|-----------------------------|
| | 1 week before transplanting | 2 weeks after transplanting | 4 weeks after transplanting |
| Fresh Tithonia (FTd) | 3 kg/m ² | 3 kg/m ² | 1,5 kg/m ² |
| Liquid Tithonia (TdL) | 0,6 L/m ² | 0,6 L/m ² | 0,3 L/m ² |
| Liquid Thevetia (TnL) | 0,6 L/m ² | 0,6 L/m ² | 0,3 L/m ² |

The beds were watered twice a day from transplanting (morning and evening). The hoeing and weeding of the alleys were carried out once a month throughout the crop cycle. This made it possible to effectively control weeds and loosen the soil for good aeration and water infiltration.

2.1.4 Collection of data

The growth parameters, on which the observations focused, are the height of the plants, the width of the leaf, the number of leaves per plant and the wingspan of the plant [12]. These parameters were measured during the dry season maintaining, for each measurement, an interval of seven days (one week) from the second week after transplanting. The measurements were taken on fifteen (15) choice lettuce plants in the center of the plot at random at the start per bed and per treatment (i.e. 45 plants considered per treatment).

Seven (7) weeks after transplanting, 8 plants were harvested randomly per bed (i.e. 32 plants/treatment) then weighed using a precision electronic scale. The mass obtained was used to calculate the yield as follows:

2.1.5 Statistical analyzes of data

The data during the present study were encoded using the Excel 2016 spreadsheet. Subsequently, the statistical analyzes were carried out using the STATISTICA 7.1 software. and the differences were considered significant at the level of $\alpha = 0.05$ ($p < 0.05$) for all tests performed. All the variables were first subjected to the Shapiro-Wilk and Levene tests in order to check respectively the normality and the homogeneity of the variances of each variable. The Kruskal-Wallis test was applied to the data which did not follow the normal distribution (Shapiro-Wilk test, $p > 0.05$) to assess the significance of the effect of the treatments applied on the growth parameters of the plants. . When this is significant ($p < 0.05$), the Mann-Whitney rank comparison test is then performed to determine the specific differences between the variables taken two by two. The analysis of variances with one classification criterion (ANOVA 1) was applied to the variables which followed the normal law to estimate the significance of their variations. Finally, the ANOVA was accompanied by Fisher's LSD test to test the significance of the means of each variable.

3. RESULTS AND DISCUSSION

3.1 Results

3.1.1 Average plant height of Lettuce in Cultivation

The average height of the lettuce plants was evaluated and recorded in Table II. The values obtained varied between 9.89 cm for the FTd treatment and 12.96 cm for the TnL treatment. The analysis of variance at the 5% threshold ($p = 0.06$) indicates that there is no significant difference between the treatments applied.

Table 2. Average values of average plant height per treatment

| Treatments | Average plant height (cm) |
|------------|-----------------------------|
| W0 | 10,25 ± 6,71 ^a |
| FTd | 9,89 ± 6,79 ^a |
| TdL | 11,75 ± 7,9776 ^a |

| | |
|-----|----------------------------|
| TnL | 12,96 ± 29,32 ^a |
| p | 0,06 |

W0 = Control; FTd = Tithoniafresh; TdL = Liquid Tithonia; TnL= Liquid Thevetia; p = significance level

3.1.2 Lettuce leaf length of Lettuce in Cultivation

Figure 4 shows the average lengths obtained with the different treatments. These averages varied from 7.01 cm to 8.10 cm. A highly significant difference ($p=0.003$) was observed between the treatments. The LSD test carried out at the 5% threshold made it possible to discriminate between the treatments in two distinct classes. According to this discrimination, the FTd treatment with a numerical value of 7.01 cm had the lowest average leaf length. On the other hand, the TdL treatment presented the high mean value (8.10 cm) of leaf length.

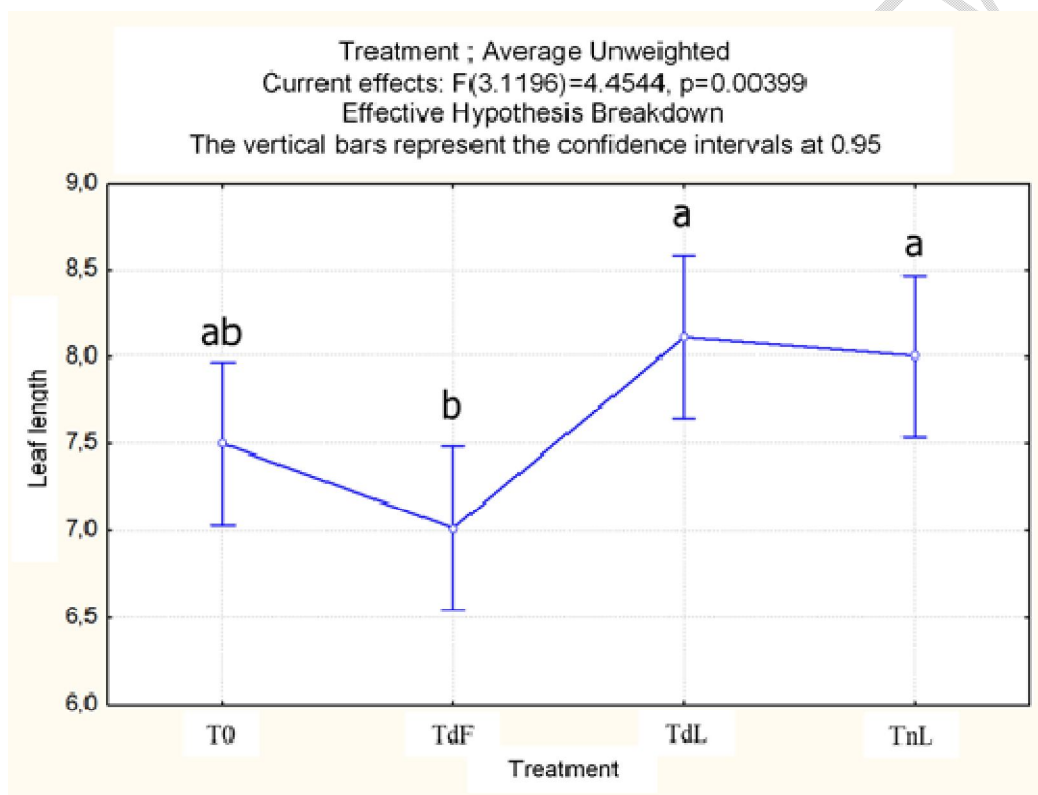

Figure 4. Average length of lettuce plants according to treatment

W0 = Control; FTd = fresh Tithonia; TdL = Liquid Tithonia; TnL = liquid Thevetia; p = significance level

3.1.3 Leaf width of Lettuce in Cultivation

Data analysis made it possible to obtain, at the 5% threshold, average leaf widths of lettuce plants per treatment (Figure 5). There were significant differences ($p = 0.01$) between the treatments in terms of lettuce leaf width. The highest leaf width values were obtained with the TdL (5.79cm) and TnL (5.70cm) treatments and the lowest with the W0 (5.15cm) and FTd (5.14cm) treatments.

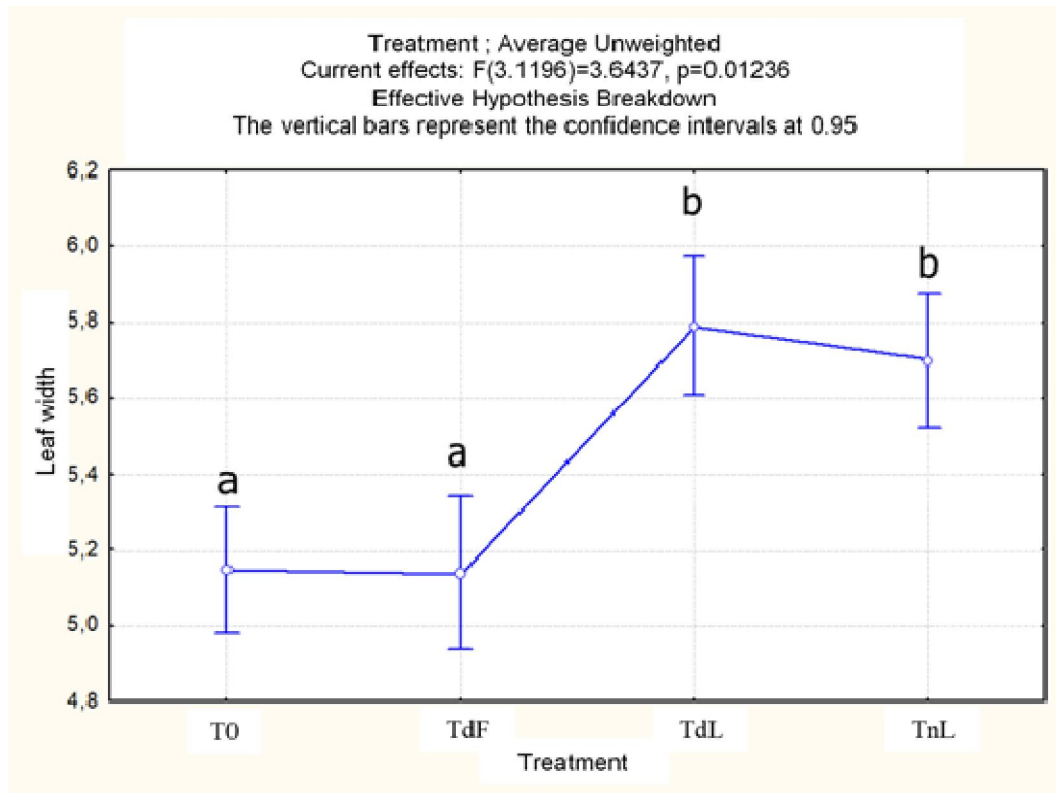

Figure 5. Average width of lettuce plants according to treatments

W0 = Control; FTd = fresh Tithonia; TdL = Liquid Tithonia; TnL = liquid Thevetia; p = significance level

3.1.4 Number of leave of Lettuce in Cultivation

The average number of leaves was determined as part of the study of the effects of different fertilizers (Figure 6). ANOVA (at the 5% threshold) revealed a significant difference ($p = 0.0001$) across all treatments. The TdL and TnL treatments produced the highest leaf counts, with averages of 5.88 and 5.62 leaves, respectively. On the other hand, the lowest average value in number of leaves was obtained with the FTd treatment (4.66 leaves).

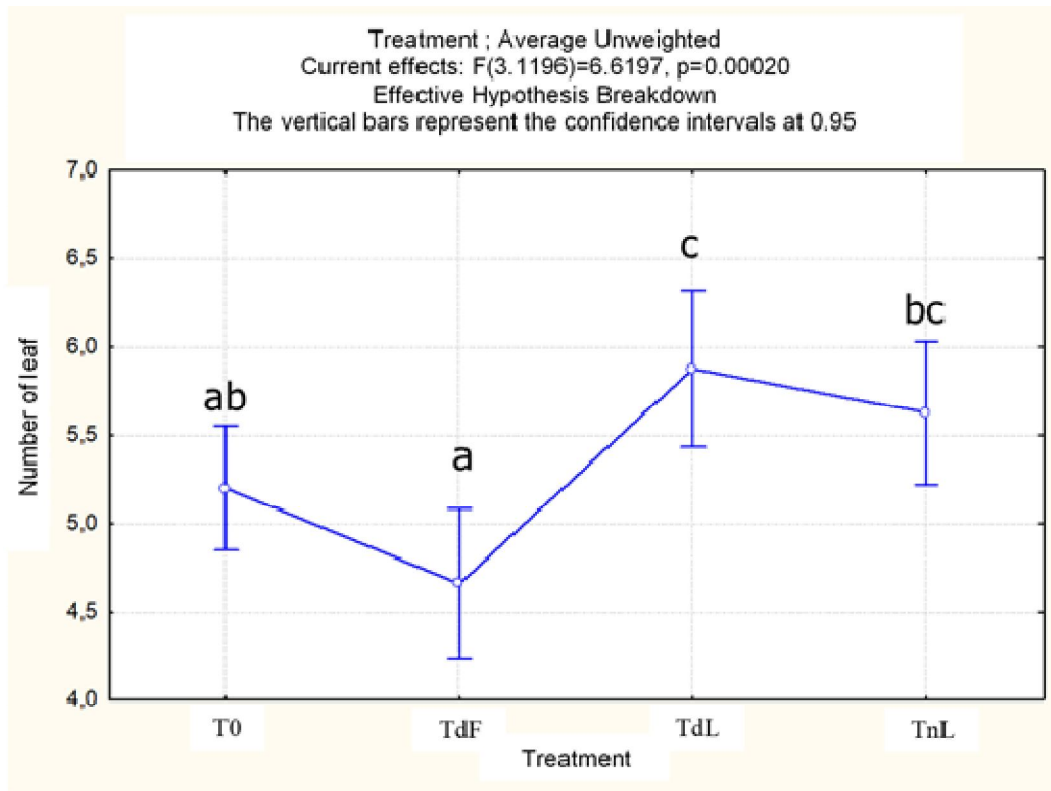

Figure 6. Average number of leaves of lettuce plants according to the treatments
W0 = Control; FTd = fresh Tithonia; TdL = Liquid Tithonia; TnL = liquid Thevetia; p = significance level

3.1.5 Plant wingspan of Lettuce in Cultivation

Figure 7 shows the results of the average span values recorded with the applied biofertilizer treatments. Statistical analysis showed a highly significant effect ($p = 0.0002$) of biofertilizers. The three biofertilizer formulations tested made it possible to obtain larger measurements; 11.15 cm for TdL, 10.55 cm for TnL and 9.49 cm for FTd. The lowest wingspan measurement was obtained by the control treatment (W0) with an average of 9.10 cm.

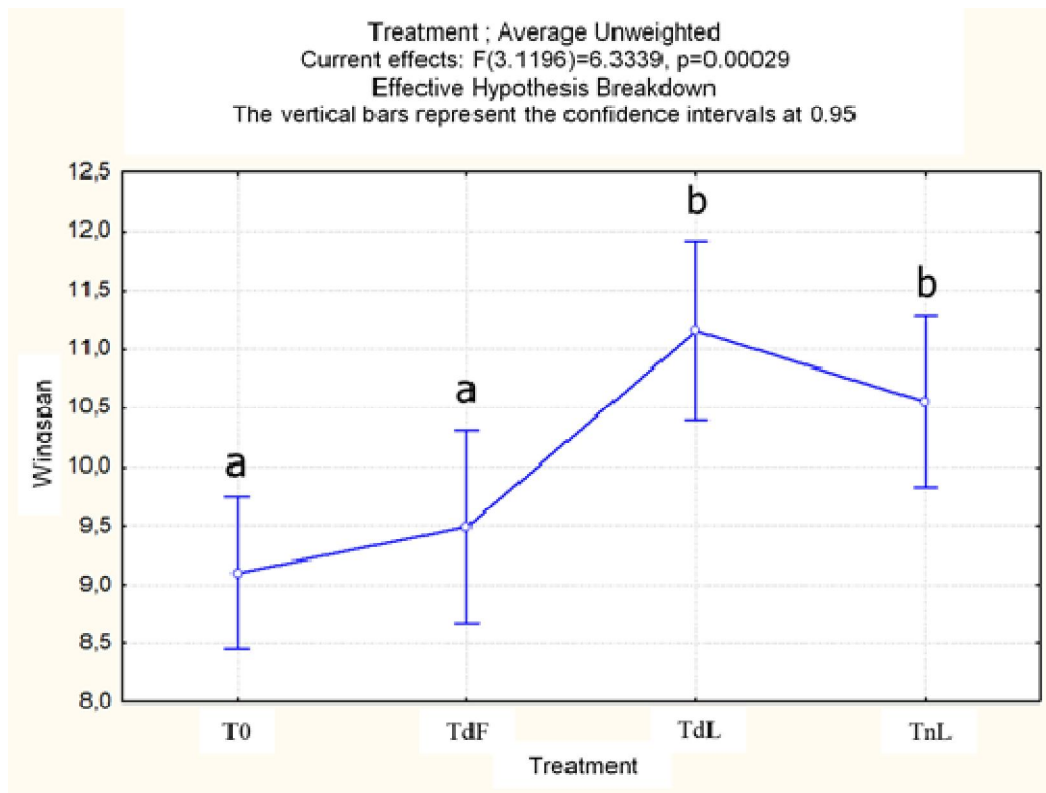

Figure 7. Average size of lettuce plants according to treatment

W0 = Control; FTd = fresh Tithonia; TdL = Liquid Tithonia; TnL = liquid Thevetia; p = significance level

3.1.6 Yield of lettuce at harvest

The effect of treatments on lettuce yield was determined and is shown in Figure 8. Statistical analysis at the 5% threshold revealed no significant difference ($p > 0.05$) between treatments. The best yields were recorded with the TdL (20.00 t/ha) and FTd (20.00 t/ha) treatments. On the other hand, the lowest yield (15.00 t/ha) was obtained from the control treatment W0.

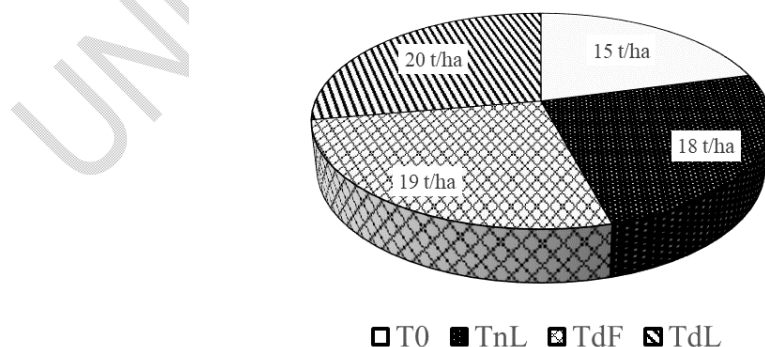

Figure 8: Lettuce yield per treatment

W0 = Control; FTd = fresh Tithonia; TdL=Liquid Tithonia; TnL = liquid Thevetia; p = significance level

3.2 Discussion

3.2.1 Vegetative growth of lettuce

The fertilizers used in this study improved overall all the parameters considered. All vegetative parameters; i.e. plant height, leaf length, leaf width, leaf number and wingspan of lettuce treated with *Tithonia* and *Thevetia* liquid were higher than those of control and fresh *Tithonia* during this trial. Statistical analyzes revealed a significant difference between the treatments. The results of the present work agree with those of [8]. These authors obtained control plants whose size is much lower than that of the fertilized plants, following the application of organic amendments to the potato. The liquid form obtained from the manure of *Tithonia diversifolia* and *Thevetia neriifolia*, would promote the decomposition of the leaves and the release of the mineral elements necessary for the plant [5].

The low average values obtained for all the growth parameters with the fresh leaves of *T. diversifolia*, would be due beforehand to the time necessary for a decomposition of the leaves incorporated in the soil followed by a progressive release of the minerals before their assimilation [11]. These results suggest that the two fertilizers of plant origin could have the same mineral elements available and improve the physico-chemical properties of the soil necessary for the good growth and development of plants. However, the natural decay time would not be favorable to the vegetative phase of short cycle plants, such as lettuce.

3.2.2 Lettuce yield

This trial demonstrated the ability of *Tithonia diversifolia* and *Thevetia neriifolia* to improve lettuce yield. The highest yields were obtained with treatments based on *T. diversifolia* (liquid and solid). These results are similar to those of [5] on maize cultivation in Cameroon and those of [7] on soy in D.R. Congo. These authors obtained high yields using fresh *T. diversifolia* as fertilizer in their respective crops. The high concentration of nitrogen (3.55%), phosphorus (0.40%), potassium (4.34%), calcium (2.81%) and magnesium (0.46%), could explain these results. Moreover, the degradation time of *Tithonia diversifolia* seems to be favorable to the reproductive phase of lettuce.

4. CONCLUSION

The present study showed that treatments based on *Tithonia diversifolia* and *Thevetia neriifolia* significantly improved lettuce growth and yield parameters. However, the treatments with liquid *Tithonia* and *Thevetia* gave the highest average values, considering their accelerated decomposition into manure. Although their effectiveness has not been compared to that of synthetic fertilizers as a reference, the results obtained thanks to these treatments constitute a good alternative for future studies, in particular, in the field of market gardening.

REFERENCES

1. Dupriez H. & Lenneer D. Tropical agriculture in an African peasant environment. Edition Terre et vie, News, 1998. English
2. Guezere A. The obsession with living in one's own house in Lomé: what impact on spatial dynamics. The Overseas Notebooks, 2011;256:565-590. French
- 3.INS. General Population and Housing Census. Implementation report and presentation of the main results. 2014. English

4. Jama B, Palm CA, Buresh RJ, Niang AI, Gachengo C & Nziguheba G. Tithonia as a green manure for soil fertility improvement in Western Kenya: a review. *Agroforestry Systems*, 2000;49:201-221.
5. Kaho F, Yemefack M, Feujio-Teguefouet P & Tchanchaoung JC. Combined effect of *Tithonia diversifolia* leaves and inorganic fertilizers on maize yields and properties of ferralitic soil in central Cameroon. *Tropicultura*, 2011;29(1):39-45. French
6. Kakai HF, Kakai AG & Tehouegnon AG. Urban agriculture and waste recovery in Benin: a sustainable development approach. *Vertigo*, 2010;10(2):1-36
7. Kasongo LME, Mwamba MT, Tshipoya MP, Mukalay MJ, Useni SY, Mazinga KM & Nyembo KL. Response of the soybean crop (*Glycine max* L. (Merril) to the contribution of green biomasses of *Tithonia diversifolia* (Hemsley) A. Gray as organic manure on a Ferralsol in Lubumbashi, R.D. Congo. *Journal of Applied Biosciences*, 2013;63 :4727-4735.English
8. Ngoyi AN, Masanga GK, Bila HM, Yashima AY, Milambo MM, Ndjibu LN. & Baboy L.L. Effect of organic amendments on the growth and yield of potato (*Solanum tuberosum*) grown on degraded soil in the Kabinda region, Democratic Republic of Congo. *International Journal of Biological and Chemical Sciences*, 2020;14(5):1812-1819. French
9. Nguo BP, World G & Seburiri ST. Effect of different organic fertilizers on eggplant cultivation in Saké (R.D. Congo). *Annals of UNIGOM*, 2016. English
10. UN 2020. Let's shape our future together.2020. Accessed 29 August 2022.
Available: <https://www.un.org/en/un75/shifting-demographics> English
11. Salla M, Abobi AHD, Coulibaly S. Traore K, Messamé Moussa Traore MM. Effects of biofertilizers based on *Tithonia diversifolia* and *Thevetia neriifolia* on lettuce production in Daloa. Center-West of Ivory Coast. *Moroccan Review of Agronomic and Veterinary Sciences*. 2022;10(3):336-340. French
12. Tchaniley L., Ayisah KD, Dewa Kassa KA. Effect of the combination of organic and mineral fertilizers (NPK 15-15-15 and urea) on the yield of lettuce (*Lactuca sativa* L.) in southern Togo. *Journal of Applied Biosciences*, 2020;151:15540-15549. French
13. Useni SY, Chukiyabo KM, Tshomba KJ, Muyambo ME, Kapalanga KP, Ntumba NF, Kasangij KP, Kyungu KA, Baboy LL, Nyembo KL, & Mpundu MM. Use of recycled human waste to increase maize (*Zea mays* L.) production on a ferral soil in southeastern DR Congo. *Journal of Applied Biosciences*, 2013;(66):5070-50811. French
14. Zro Bi GF, Guéi AM, Nangah KY, Soro D & Bakayoko S. Statistical approach to the analysis of the variability and fertility of vegetable soils of Daloa (Côte d'Ivoire). *African Journal of Soil Science*, 2016;4(4):328-338.