

MODELLING AND OPTIMIZATION OF NATURAL GAS DEHYDRATION SYSTEM USING TRIETHYLENE GLYCOL

Abstract

The problem with water vapour in natural gas stream, threaten the process facilities if the dew point temperature is not properly managed. Hydrate formation is inevitable at temperatures below the dew point. It becomes very important to reduce the water content in the gas stream to below or within the acceptable limit of 6-7lb/MMSCFD. There are many methods that can be used to reduce the water content in the natural gas stream of which adsorption and absorption are one of them, in this work absorption was employed. Natural gas composition analysis was carried out and Industrial data of a natural gas dehydrating plant was obtained and simulated using Aspen Hysys software. Process conditions of 72.6 barg and 38°C and gas flow rate of 10 lb/mm scfd, were inputted into the software and simulated. Different TEG flow rates were used for the simulation. Results obtained show that for a TEG of 3.5m³/h (0.1480 kgmole/h), the water content in the dry gas was 6.6333 lb/MMSCF which is within the acceptable water limit and when the TEG flow rate was increased up to 15.7m³/h (0.6640kgmole/h) the water content in the dry gas was further reduced to 1.0930 lb/MMSCF from an initial value of 19.84lb/MMSCF. For the first simulation, a reboiled still column was used and 88% of TEG was recovered and 12% was lost with water vapour at the top of the still column but after the second simulation where a recovery separator, still column with reboiler and reflux condenser were used, 99.98% of the TEG was recovered which was compared with other methods in the industry. This implies that for a higher purity of TEG to be achieved, a recovery separator and a reflux still column needs to be used because increasing the reflux reduces glycol loss. The sum of the total capital cost and glycol loss per year is 3,873,590 USD for simulation 1, while there is a negligible TEG loss in simulation 2 so the total capital cost is 3,863,380 USD and the two simulations have the same energy consumption of 114,300KJ/h.

Keywords: Gas Dehydration; TEG; Natural gas; Absorption; Hydrate; Industrial data; Feed; Product.

Introduction

Dehydration is an important process in offshore gas processing. The gas is dehydrated offshore to avoid dangers associated with pipeline transport and processing of wet gas. The problems include corrosion, water condensation and plugs created by ice or gas hydrates ^[1].

Thermodynamic simulation of gas dehydration is difficult due to the interaction between water and glycol. The interaction is due to non-ideal liquid behavior of water and glycol mixture. The interaction is impossible to simulate with the normally used thermodynamic equations of state like Peng-Robinson. The glycol dehydration process is an example of a process that provides absorption

dehydration, and in the process, a liquid desiccant provides the means to absorb water from the gas stream. Ethylene glycol ($\text{HOCH}_2\text{CH}_2\text{OH}$) was, initially, the principal chemical agent in this process, which has a very strong affinity for water and when the glycol is in contact with a stream of water-wet natural gas, the ethylene glycol absorbs the water from the gas stream. Initially, the process used ethylene glycol as the absorbent but, with the advancement of the technology, glycol dehydration now involves the use of an aqueous solution of a glycol derivative in which the glycol is either diethylene glycol (DEG) or triethylene glycol (TEG), which is brought into contact with the water-wet gas stream in a contactor [1].

The glycol solution will absorb water from the wet gas and, once absorbed, the glycol sinks to the bottom of the contactor while the natural gas, stripped of most of the water content, is then transported out of the dehydrator. The glycol solution, bearing all of the water stripped from the natural gas, is put through a specialized boiler designed to vaporize only the water out of the solution where the boiling point differential facilitates removal of the water which makes it relatively easy to remove water from the glycol solution after which the glycol is recycled to the contactor [2].

Water vapour in natural gas stream, poses threat to process facilities if the dew point temperature is not properly controlled which will result in huge loss of money as condensate

will be formed along the process line. Hydrate formation is imminent at temperatures below the dew point. It becomes very important to reduce the water content in the gas stream to below or within the tolerated limit of 6-7lb/MMSCFD [3]. Also, loss of glycol constitute one of the most important operating problems of gas dehydration units. Most of this loss occurs as carry-over of solution with the product gas, although small amount of glycol is lost by vaporization into the gas stream. A small amount is always lost through mechanical leakage, and some may be lost with the vapors leaving the regenerator [4]. We aim to improve the plant efficiency and account for the amount of water removed and glycol regenerated. Since a pure glycol (up to 99.9%) is required in order to be sent back to the contactor column again for reuse without having to feed in a fresh Triethylene Glycol so as to reduce cost.

Methodology

Glycols used for dehydration

Glycol is a common name for diols; with the two alcohols these substances have a high affinity for water. In dehydration 1,2-ethandiol also known as Monoethylene glycol (MEG) and the small polymers of MEG (diethylene glycol (DEG), triethylene glycol (TEG) and tetraethylene glycol (TREG)) are the most commonly used for absorbents. Higher polymers than TREG is usually not used for dehydration because they become too viscous compared to the smaller polymers [1]

Properties for MEG, DEG, TEG, TREG and water are compared in Table 1 ^[1]

Table 1 Properties for MEG, DEG, TEG, TREG and water

	MEG	DEG	TEG	TREG	Water
Formula	C ₂ H ₆ O ₂	C ₄ H ₁₀ O ₃	C ₆ H ₁₄ O ₄	C ₈ H ₁₈ O ₅	H ₂ O
Molar mass [kg/kmol]	62.07	106.12	150.17	194.23	18.015
Normal boiling point [°C]	197.1	245.3	288.0	329.7	100.0
Vapor pressure @ 25 °C [Pa]	12.24	0.27	0.05	0.007	3170
Density @ 25 °C [kg/m ³]	1110	1115	1122	1122	55.56
Viscosity @ 25 °C [cP]	17.71	30.21	36.73	42.71	0.894
Viscosity @ 60 °C [cP]	5.22	7.87	9.89	10.63	0.469
Maximum recommended regeneration Temperature [°C]	163	177	204	224	-
Onset of decomposition [°C]	-	240	240	240	-

In Table 1, the important values are the normal boiling point, vapor pressure, viscosity, maximum recommended regeneration temperature and the onset of decomposition ^[1].

The normal boiling point and vapor pressure has an influence in the distillation. The greater the difference for these properties between the top and bottom product, the easier it is to separate the components. The separation between glycol and water is important because the water contents in the lean glycol determine the amount of water the glycol can remove from the gas.

The decomposition temperature is the point where DEG, TEG and TREG begin to react with the water and decompose into MEG. These temperatures are just below and above the maximum recommended regeneration temperature of 204 °C (400 °F). This indicates that some TEG will decompose at 204 °C. At this temperature there will be some hot-spots in the boiler where the temperature will exceed 207 °C. When TEG decomposes it becomes MEG and DEG, therefore it will not influence the dehydration process, only give a slightly larger glycol loss because MEG and DEG are more volatile than TEG ^[1].

Table 2 Compositions of raw natural gas ^[5].

Compositions	Chemical Formula	Percentage
Methane	CH ₄	70-90%
Ethane	C ₂ H ₆	
Propane	C ₃ H ₈	0-20%
Butane	C ₄ H ₁₀	
Carbon Dioxide	CO ₂	0-8%
Oxygen	O ₂	0-0.2%
Nitrogen	N ₂	0-5%
Hydrogen sulphide	H ₂ S	0-5%
Rare gases	Ar, He, Ne, Xe	trace

Table 3 Process Conditions

Process Conditions	Value
Temperature	38 °C
Pressure	72.6 barg
Flow rate	10 MMSCFD

Water Composition and Condition ^[7]

Parameters	Values
Temperature	30 °C
Pressure	92 bar
Mole Fraction	1.000
Flow rate	0.5 kgmole/h
Fluid Package	Glycol Package

TEG flow rates are: 3.5m³/h, 4.2m³/h, 4.5m³/h, 5.4m³/h, 15.7m³/h, 25.0m³/h, 30.0m³/h, 50.0m³/h and 60.0m³/h

Process description

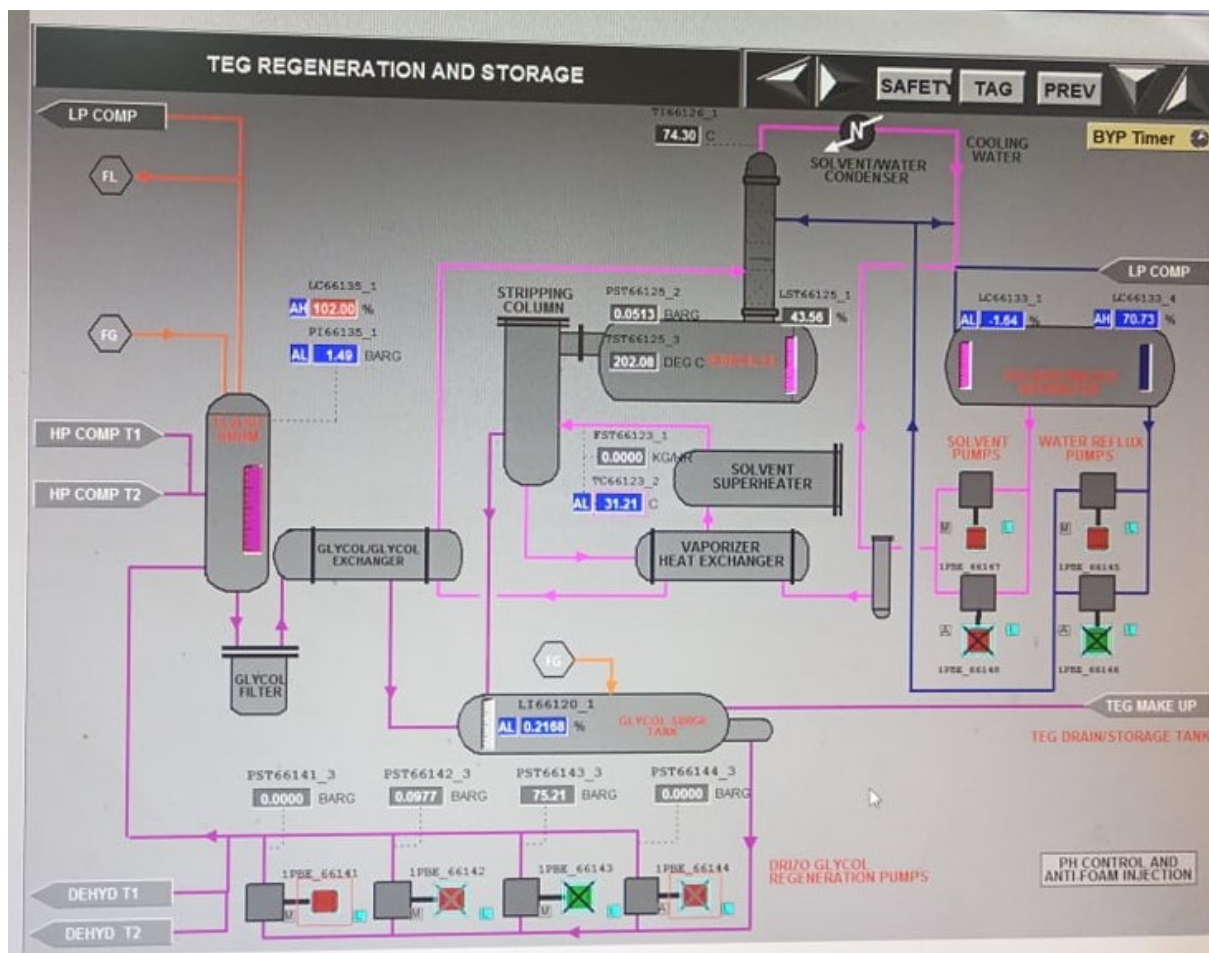

Figure 1: Natural Gas Dehydration System flow sheet

Industrial Standard Operating Procedure (SOP) [7].

Figure 1 above shows the industrial process flow diagram (PFD) of the natural gas dehydration unit and natural gas processing unit which will be used to validate the model developed by the researcher. The natural gas and water is fed to a mixer where there is a partial mixing, the wet gas is passed through a

valve into the contactor for easy flow control. In the absorber (contactor), the wet gas is fed at the bottom at 38°C and 72.6 barg and the lean glycol is fed at 38°C and 2 barg at the top for a thorough mixing. After mixing, the glycol will absorb the water in the wet gas and move to the bottom of the contactor and the dry gas will move to the top of the contactor and leave the system for other processes. Figure 2 shows the complete process flow diagram.

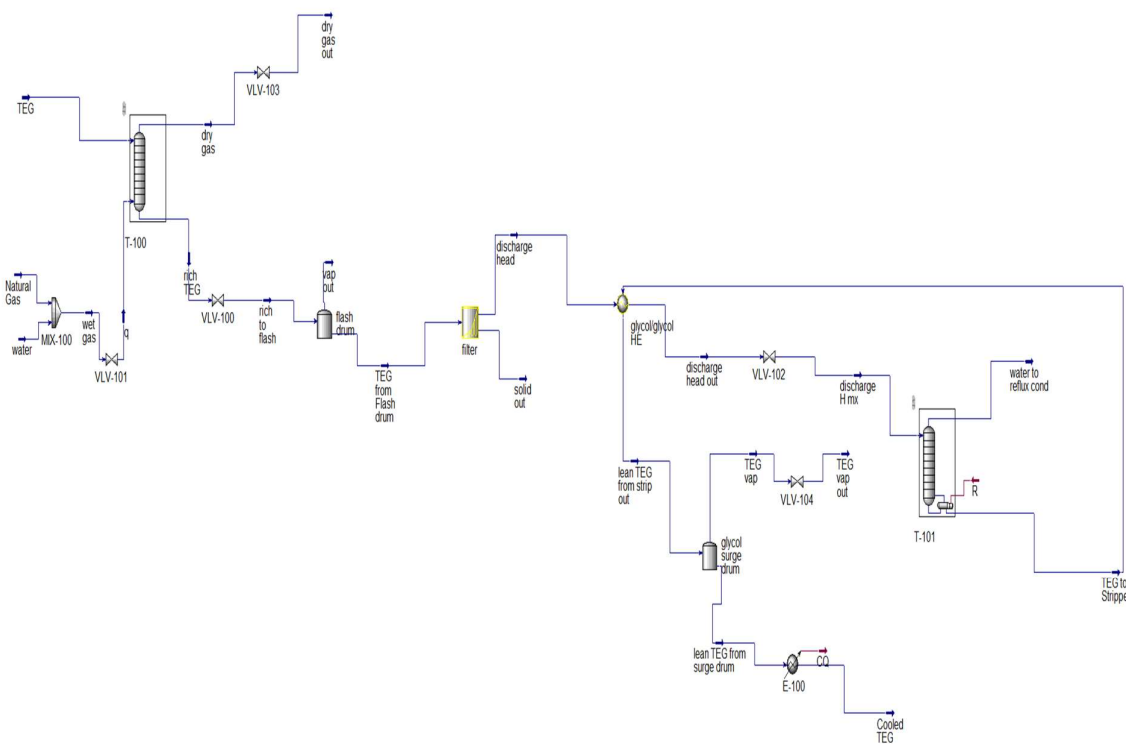

Figure 2 The dehydration unit

Rich TEG, which has absorbed water from the gas stream, flows out of the dehydrator column at 37.8 °C and 72.6 barg, to the regeneration package. It first enters the vertical glycol flash drum operating at 2 barg. The large pressure drop from the dehydrator column via the rich glycol level control valve allows the release of hydrocarbon gases dissolved in the glycol. The rich glycol from the glycol flash drum is filtered to remove any contaminants to prevent these solids from fouling the heat transfer surfaces within the glycol regeneration package. The rich glycol from the filter is heated by the lean glycol exiting the still column via the solvent vaporizer heat exchanger. The glycol/glycol heat exchanger is a tubular heat exchanger using hot lean glycol from the

stripping column as heating medium (shell side). Rich glycol (tube side), enters at 38°C and leaves the glycol/glycol heat exchanger at 171°C.

The glycol regeneration section includes the glycol reboiler, the glycol still column and the stripping column. The purpose of this section is to remove the water contained in the rich glycol. The glycol in the glycol reboiler is heated to 204°C. The generated vapors pass up the rich glycol still column along with any volatile material not released at the flash drum and are contacted with liquid traveling down the column. The still column is packed with random packing to ensure good contact between vapor and liquid phases. The glycol is sent to the

surge drum, the glycol surge drum provides a buffer volume for the circulating glycol. The lean glycol enters in the vessel from the glycol/glycol heat exchanger at a temperature of approximately 72°C. The lean glycol will be cooled again with a trim cooler before being fed back into the absorber. This trim cooler can either be a cross-exchanger with the dry gas leaving the absorber or an air-cooled exchanger.

Modification of the Process for optimisation.

Figure 3 shows a modified process flow diagram, where the same industrial parameters are used but a slight change in SOP as new equipment are added to improve the process in order to minimize the proposed TEG loss.

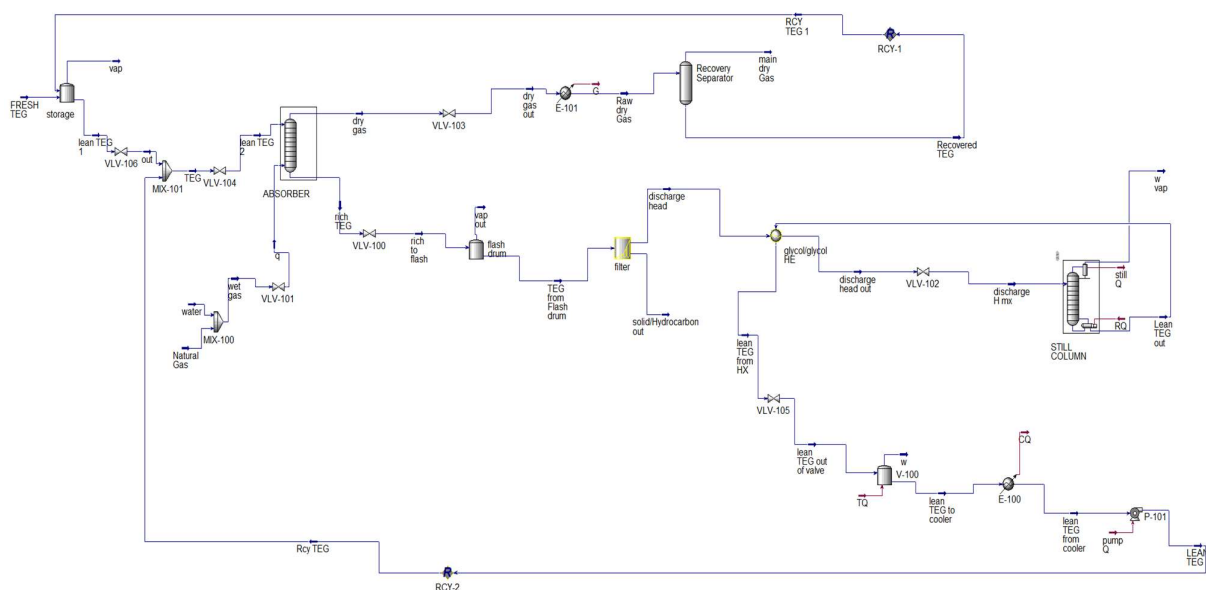

Figure 3 Modified process flow diagram

In the absorber (contactor), the wet gas is fed at the bottom at 38°C and 72.6 barg and the lean glycol is fed at 38°C and 2 barg at the top for a thorough mixing. After mixing, the glycol will absorb the water in the wet gas and move to the bottom of the contactor and the dry gas will move to the top of the contactor where it passes through a heat exchanger and is sent to a separator so that any TEG that might have escaped with the gas will be collected and

returned back to the storage tank as reflux so as to make up for TEG loss and also improve the contactor operation.

The glycol regeneration section includes the glycol reboiler, the reflux condenser, the glycol still column and the stripping column. The reflux condenser is added so that it can condense the water vapor leaving the still column and recover any trace of TEG leaving with the water vapor.

Results

Gas Dehydration (Water Removal)

Different flow rate of TEG was used for the simulation with initial water flow rate of 0.5kgmole/hr which resulted to different amount of water removal out of the wet gas. When the flow rate of the used TEG was 3.5m³/hr (0.1480kgmole/hr), 0.3328kgmole/h water was removed while 0.1672kgmole/h (6.6333 lb/mm scf) water was still remaining in the dry gas which is within the standard acceptable water content limit and 97.26% (0.9726 mole fraction) of methane was achieved

The TEG flow rate was raise to 4.2m³/hr (0.1776kgmole/h) and 0.3547kgmole/h water was removed while 0.1453kgmole/h (5.765 lb/mm scf) was remaining in the dry gas, which yield no change in the methane content from the previous flow rate.

For the TEG flow rate of 4.5m³/hr (0.1903kgmole/h), 0.3628kgmole/h was removed and 0.1372kgmole/h (5.444 lb/mm scf) was still remaining in the dry gas and there was still no change in the methane content of the dry natural gas.

For a TEG flow rate 5.4m³/hr (0.2284kgmole/h), 0.3837kgmole/h was removed and 0.1163kgmole/h (4.616 lb/mm scf) was still remaining in the dry gas and there was a small fraction of change in the methane content of the dry natural gas.

Since a fraction change in methane content was noticed from the last flow rate used; therefore, the flow rate was raise significantly to 15.7m³/hr (0.6640kgmole/h) to check if more methane can be recovered and there was a corresponding reduction of water content in the

dry gas from 0.1163kgmole/h of TEG flow rate of 5.4m³/hr to 0.0275kgmole/h (1.0930 lb/mm scf) thereby removing 0.4725kgmole/h of water from the wet gas and also there was a change in the mole fraction of methane in the natural gas from 0.9726 to 0.9728.

In other to keep recovering more of the methane, the TEG flow rate was increased to 25.0m³/hr (1.057kgmole/h) and it was observed that all of the methane (0.9729) was recovered. Also there was a corresponding reduction in water content in the dry gas to 0.0111kgmole/h (0.1992m³/h, 0.4388 lb/mm scf), showing that 0.4889 kgmole/h quantity of water was removed.

To further reduce the water content, TEG flow rate of 30m³/hr was simulated and 0.4926kgmole/h water was removed from the wet gas thereby leaving the dry gas with only 0.0074kgmole/h (0.2938 lb/mm scf) of water which is shown in Table 4 below. Further increase in flow rate of TEG above 30.0m³/hr (such as 50.0m³/hr and 60.0m³/hr below) yielded negligible change in the water content of the dry gas and will not yield any further increase in the methane content since it has already been achieved with a flow rate of 25.0m³/hr.

Table 4: TEG Rate and Water Content

TEG Rate (m ³ /hr)	Water content (lb/MMSCF)
3.5	6.6333
4.2	5.7650
4.5	5.4440
5.4	4.6160
15.7	1.0930
25.0	0.4388
30.0	0.2938
50.0	0.0392
60.0	0.0544

From the Table 4 above, it can be observed that the amount of water content in the natural gas reduces as TEG flow rate increases.

Figure 4: Plots of TEG Rate and Water Content

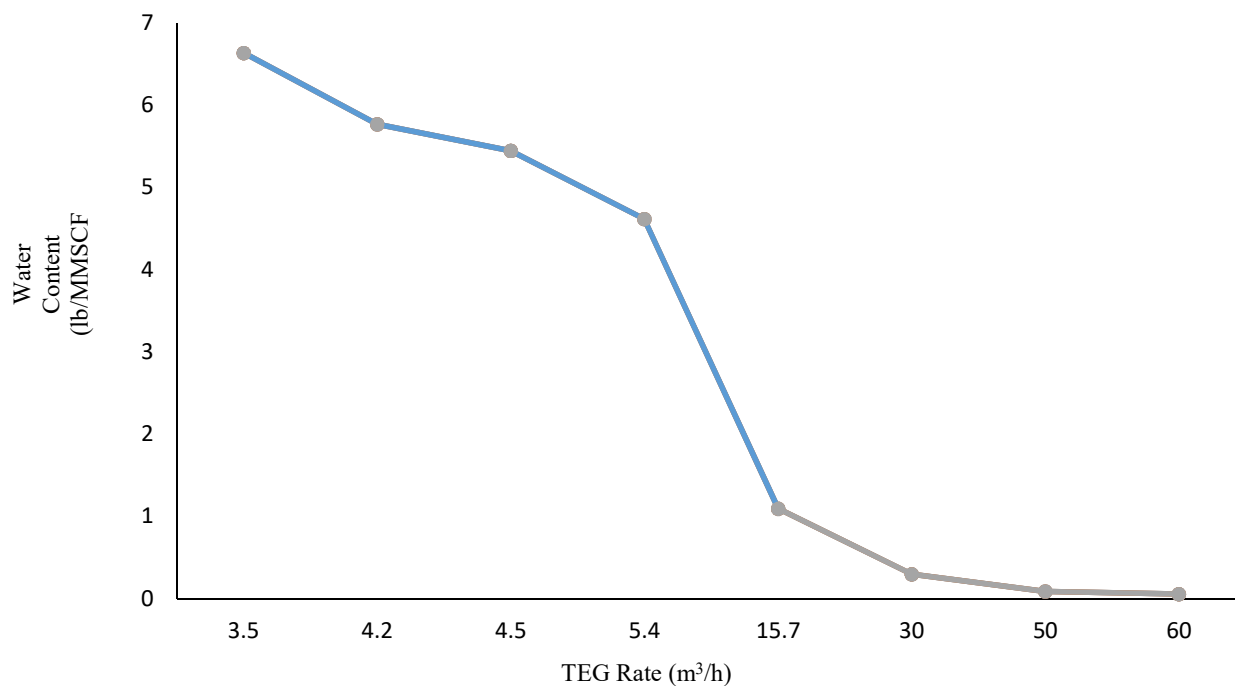

The curve shows an inverse relationship between the TEG rate and the water content. As it is expected, high flow rate of TEG will absorb more of the water present in the natural gas stream and low flow rate will absorb less water from the gas stream.

TEG Regeneration

Industrial result

To maintain the water content of the natural gas within the standard limit of 6-7lb/mmscf; 3.5m³/hr (0.1480 kgmole/h) flow rate of TEG is used, which yielded water content in the dry natural gas to be 6.6333 lb/mmscf (0.1672 kgmole/h). Also after absorbing some of the water content in the wet gas, the rich TEG was now sent for regeneration in the still column where the solution is heated

up to 204°C to yield all its water content and after which 0.1303 kgmole/h TEG was recovered meaning that 12% of TEG was lost in the process.

Table 5. shows the process result of the simulation indicating that 0.1480 kgmole/h (3.5m³/hr) was inputted and 0.1303kgmole/h (3.08m³/h) was regenerated as cooled TEG from the still column.

Table 5: Process Result

	<i>Unit</i>	Natural Gas	water	wet gas	TEG	dry gas
Vapour Fraction		1.0000	0.0000	1.0000	0.0000	1.0000
Temperature	<i>C</i>	38.0000	38.0000	37.0702	38.0000	37.7099
Pressure	<i>kPa</i>	7361.3250	7361.3250	7361.3250	7401.3250	7361.3250
Molar Flow	<i>kgmole/h</i>	498.0708	0.5000	498.5708	0.1480	498.2365
Mass Flow	<i>kg/h</i>	8269.4672	9.0076	8278.4748	22.2267	8272.4640
Liquid Volume Flow	<i>m3/h</i>	26.8709	0.0090	26.8800	0.0197	26.8739
Heat Flow	<i>kJ/h</i>	-38950572.5514	-142387.4902	39092960.0416	120369.9410	-38997609.1105
		rich TEG	q	rich to flash	vap out	TEG from Flash drum
Vapour Fraction		0.0000	1.0000	0.0028	1.0000	0.0000
Temperature	<i>C</i>	37.3598	37.0702	39.1285	39.1285	39.1285
Pressure	<i>kPa</i>	7361.3250	7361.3250	361.3250	361.3250	361.3250
Molar Flow	<i>kgmole/h</i>	0.4823	498.5708	0.4823	0.0013	0.4810
Mass Flow	<i>kg/h</i>	28.2374	8278.4748	28.2374	0.0252	28.2123
Liquid Volume Flow	<i>m3/h</i>	0.0258	26.8800	0.0258	0.0001	0.0257
Heat Flow	<i>kJ/h</i>	-215740.2478	39092960.0416	-215740.2478	-133.7328	-215606.5150
		discharge head	solid out	lean TEG from strip out	discharge head out	dry gas out
Vapour Fraction		0.0000	0.0000	0.0000	0.5638	1.0000
Temperature	<i>C</i>	39.1285	39.1285	72.0000	171.0000	37.7099
Pressure	<i>kPa</i>	361.3250	361.3250	131.3250	201.3250	7361.3250
Molar Flow	<i>kgmole/h</i>	0.4810	0.0000	0.1303	0.4810	498.2365
Mass Flow	<i>kg/h</i>	28.2123	0.0000	19.4204	28.2123	8272.4640
Liquid Volume Flow	<i>m3/h</i>	0.0257	0.0000	0.0172	0.0257	26.8739
Heat Flow	<i>kJ/h</i>	-215606.5150	0.0000	-103524.8912	192849.8351	-38997609.1105
		discharge H mx	TEG to Stripper	water to reflux cond	lean TEG from surge drum	TEG vap
Vapour Fraction		0.5638	0.0000	1.0000	0.0000	1.0000
Temperature	<i>C</i>	171.0000	286.1163	200.5435	72.0000	72.0000
Pressure	<i>kPa</i>	201.3250	131.3250	131.3250	131.3250	131.3250
Molar Flow	<i>kgmole/h</i>	0.4810	0.1303	0.3508	0.1303	0.0000
Mass Flow	<i>kg/h</i>	28.2123	19.4204	8.7919	19.4204	0.0000
Liquid Volume Flow	<i>m3/h</i>	0.0257	0.0172	0.0085	0.0172	0.0000

Heat Flow	<i>kJ/h</i>	-192849.8351	-90481.1074	-90885.8854	-	103524.8912	0.0000
		TEG vap out	Cooled TEG				
Vapour Fraction		0.0000	0.0000				
Temperature	<i>C</i>	252.8953	38.0000				
Pressure	<i>kPa</i>	131.3250	131.3250				
Molar Flow	<i>kgmole/h</i>	0.0000	0.1303				
Mass Flow	<i>kg/h</i>	0.0000	19.4204				
Liquid Volume Flow	<i>m3/h</i>	0.0000	0.0172				
Heat Flow	<i>kJ/h</i>	0.0000	-105496.2909				

Modification of the Process

The process above was unable to achieve 100% TEG recovery; therefore, process was modified by changing the simple still column used at the regeneration stage to full reflux still column, and adding a recovery separator to the contactor unit so as to recover any TEG that may be carried over by the process gas as a result of high vapor pressure or high level of TEG in the absorber, so that the

separator will help to recover it and return it to the storage tank for makeup.

After the simulation, 100% (0.6640 kgmole/h) of TEG was recovered from the initial TEG of 0.6640 kgmole/h used (i.e no loss).

Table 6 shows that 100% (0.6640kgmole/h) of TEG was recovered from the initial TEG of 0.6640 kgmole/h used (i.e no loss).

Table 6: Modified Process Result

	<i>Unit</i>	Natural Gas	water	wet gas	FRESH TEG	dry gas
Vapour Fraction		1.0000	0.0000	1.0000	0.0000	1.0000
Temperature	<i>C</i>	38.0000	38.0000	37.0702	38.0000	38.2501
Pressure	<i>kPa</i>	7361.3250	7361.3250	7361.3250	71595.0424	7361.3250
Molar Flow	<i>kgmole/h</i>	498.0708	0.5000	498.5708	0.6640	498.0902
Mass Flow	<i>kg/h</i>	8269.4672	9.0076	8278.4748	99.7122	8269.7955
Liquid Volume Flow	<i>m3/h</i>	26.8709	0.0090	26.8800	0.0884	26.8710
Heat Flow	<i>kJ/h</i>	-38950572.5514	-142387.4902	-39092960.0416	-534175.0686	-38950787.3838
		rich TEG	q	rich to flash	vap out	TEG from Flash drum
Vapour Fraction		0.0000	1.0000	0.0059	1.0000	0.0000
Temperature	<i>C</i>	37.6863	37.0702	39.5940	39.5940	39.5940
Pressure	<i>kPa</i>	7361.3250	7361.3250	361.3250	361.3250	361.3250
Molar Flow	<i>kgmole/h</i>	1.1446	498.5708	1.1446	0.0068	1.1379
Mass Flow	<i>kg/h</i>	108.3915	8278.4748	108.3915	0.1289	108.2626
Liquid Volume Flow	<i>m3/h</i>	0.0973	26.8800	0.0973	0.0004	0.0970
Heat Flow	<i>kJ/h</i>	-676424.6602	-39092960.0416	-676424.6602	-680.1055	-675744.5546

		lean TEG from HX	discharge head out	dry gas out	discharge H mx	lean TEG from cooler
Vapour Fraction		0.0000	0.1642	1.0000	0.1642	0.0000
Temperature	<i>C</i>	72.0000	171.0000	38.2501	171.0000	56.5231
Pressure	<i>kPa</i>	131.3250	201.3250	7361.3250	201.3250	131.3250
Molar Flow	<i>kgmole/h</i>	0.6639	1.1379	498.0902	1.1379	0.6639
Mass Flow	<i>kg/h</i>	99.6747	108.2626	8269.7955	108.2626	99.6747
Liquid Volume Flow	<i>m3/h</i>	0.0883	0.0970	26.8710	0.0970	0.0883
Heat Flow	<i>kJ/h</i>	-530336.4128	-624323.6882	-38950787.3838	-624323.6882	-534920.2333
		Lean TEG out	lean TEG out of valve	w	lean TEG to cooler	LEAN TEG
Vapour Fraction		0.0000	0.0000	1.0000	0.0000	0.0000
Temperature	<i>C</i>	300.4766	72.0000	91.5231	91.5231	57.3592
Pressure	<i>kPa</i>	131.3250	131.3250	131.3250	131.3250	7591.3250
Molar Flow	<i>kgmole/h</i>	0.6639	0.6639	0.0000	0.6639	0.6639
Mass Flow	<i>kg/h</i>	99.6747	99.6747	0.0000	99.6747	99.6747
Liquid Volume Flow	<i>m3/h</i>	0.0883	0.0883	0.0000	0.0883	0.0883
Heat Flow	<i>kJ/h</i>	-458399.5620	-530336.4128	0.0000	-524572.4128	-534014.5456
		w vap	Raw dry Gas	main dry Gas	Recovered TEG	RCY TEG 1
Vapour Fraction		1.0000	1.0000	1.0000	0.0000	0.0000
Temperature	<i>C</i>	201.3646	38.2496	38.2496	38.2496	38.2496
Pressure	<i>kPa</i>	1601.3250	7361.2250	7361.2250	7361.2250	7361.2250
Molar Flow	<i>kgmole/h</i>	0.4740	498.0902	498.0902	0.0000	0.0000
Mass Flow	<i>kg/h</i>	8.5878	8269.7955	8269.7955	0.0000	0.0000
Liquid Volume Flow	<i>m3/h</i>	0.0087	26.8710	26.8710	0.0000	0.0000
Heat Flow	<i>kJ/h</i>	-112127.9030	-38950788.3838	-38950788.3838	0.0000	0.0000
		Rcy TEG	lean TEG 1	vap	lean TEG 2	TEG
Vapour Fraction		0.0000	0.0000	1.0000	0.0000	0.0000
Temperature	<i>C</i>	57.3592	57.4887	57.4887	57.4887	57.4887
Pressure	<i>kPa</i>	7591.3250	7361.2250	7361.2250	7361.2250	7361.2250
Molar Flow	<i>kgmole/h</i>	0.6639	0.6640	0.0000	0.6640	0.6640
Mass Flow	<i>kg/h</i>	99.6747	99.7122	0.0000	99.7122	99.7122
Liquid Volume Flow	<i>m3/h</i>	0.0883	0.0884	0.0000	0.0884	0.0884
Heat Flow	<i>kJ/h</i>	-534014.7028	-534175.0686	0.0000	-534175.0686	-534175.0686
		out				
Vapour Fraction		0.0000				
Temperature	<i>C</i>	57.4887				
Pressure	<i>kPa</i>	7361.2250				
Molar Flow	<i>kgmole/h</i>	0.6640				
Mass Flow	<i>kg/h</i>	99.7122				
Liquid Volume Flow	<i>m3/h</i>	0.0884				
Heat Flow	<i>kJ/h</i>	-534175.0686				

From Figure 5 below, the composition shows that there are some traces of TEG that left with the gas stream at the top of the absorber which was recovered using the recovery

separator and recycled back to the storage tank to make up for the TEG need, and to minimize loss.

The screenshot shows the 'Material Stream: RCY TEG 1' window in Aspen Hysys. The 'Worksheet' tab is active, displaying a table of mole fractions and liquid phase compositions for various components. The total mole fraction is 1.00000.

	Mole Fractions	Liquid Phase
Methane	0.0279	0.0279
Ethane	0.0009	0.0009
Propane	0.0002	0.0002
i-Butane	0.0007	0.0007
n-Butane	0.0001	0.0001
i-Pentane	0.0005	0.0005
Nitrogen	0.0000	0.0000
H2S	0.0002	0.0002
CO2	0.0029	0.0029
H2O	0.0387	0.0387
TEGlycol	0.9278	0.9278
n-Pentane	0.0000	0.0000
Total	1.00000	

Figure 5 Recycled composition

Economic Analysis

Aspen Hysys Ver.11 software estimated the economic analysis of the two processes.

Table 7 shows the cost values and the desired rate of return of the Simulations 1 and 2:

Simulation 1 is the dehydration unit without a recovery separator

Simulation 2 is the modified process flow with a recovery separator

Table 7: Summary of Cost Analysis for Simulation 1 and 2

Cost	Simulation 1	Simulation 2
Total Project Capital Cost (USD)	3748790	3863380
Glycol loss per year (USD)	124800	0
Total Operating Cost (USD)	1334920	1337710
Total Utilities Cost (USD)	69836.3	69836.3
Equipment Cost (USD)	175800	221800
Energy Consumption (KJ/h)	114,300	114,300
Desired Rate of Return (Percent/Year)	20	20
Total Installed Cost (USD)	681400	909700

Discussion

The discussion is divided into these Sections

- Water removal
- Industrial dehydration system
- Modification of the dehydration system

Water removal

At TEG rate of 3.5m³/hr, the water content is 6.6333lb/MMSCF, which is within the water content limit in natural gas. Therefore,

using a flow rate as high as 15m³/hr and above may not add significant financial value to the revenue derived from the sales of the gas, but it will remove more water condensate from the gas which will help to get a purer natural gas free of condensate to make further processes easier, other than having condensates still in the natural gas which will lead to further condensate removal processes on the side of the end-users (clients) because this condensate are not needed in their processes.

Table 8: Results

	Flow Rate (m³/hr)	Water Content MMSCF	Methane (Kgmole/h)
Industry	3.5	6.6333	484.5719
Researcher	3.5	6.6333	484.5719

The condensate removed from an assumed dry natural gas as a result of poor dehydration is drained, this is a lost to the company as this condensate will either be returned to the Gas Company for compensation or be burnt out. Therefore, more condensate needs to be removed before sales.

However, it is important for the process engineer to know the minimum tolerated limit of water in the gas stream and what flow rate of TEG to use in order to obtain this tolerable limit, so as not to flood the contactor with TEG (which can cause liquid carryover) and still not add any significant financial value to the processed gas [3].

Industrial Dehydration System

The system is design to represent what is obtainable in the industry with TEG flow rate of 3.5m³/hr and operating procedures. After simulating, it was observed that a total amount

of water removed was 0.3508 kgmole/h and 12% of glycol was lost in the process which was assume to be at the top of the absorber and also at the regeneration stage.

Modification of the Process

The system is redesign to modify what is obtainable in the industry so that there will be no loss of glycol in the system and this was achieved by introducing a recovery separator at the absorption column which can serve as a reflux drum to recover any glycol that might have vaporized with the dry natural gas as a result of high vapor pressure of the gas or high level of TEG in the column which will cause an overflow and return it back to the storage tank as recycle, this is done to make up for the glycol need for the process without having to feed in fresh glycol and it was observed that 99.98% of TEG was recovered. Also using a reflux drum at the regeneration section will also help to recover

any glycol which might vaporized with water vapor as well.

Economic Analysis

The simulated data (total capital cost, total operating cost, total utility cost, equipment cost and total installed cost) obtained for the economic analysis of the first simulation (simulation 1) are shown in Table 7. The costs are 3,748,790 USD, 1,334,920 USD, 69,836.3 USD, 175, 800 USD and 681,400 USD respectively. The sum of the total capital cost and glycol loss per year is 3,873,590 USD.

The simulated data (total capital cost, total operating cost, total utility cost, equipment cost and total installed cost) obtained for the economic analysis of the second simulation (simulation 2) are shown in Table 8. The costs are 3,863,380 USD, 1,337,710 USD, 69,836.3 USD, 221,800 USD and 909,700 USD respectively. There is n TEG loss so the total capital cost is 3,863,380 USD.

The total capital cost for simulation 2 is higher than that of simulation 1 as a result of new equipment added but when the cost of TEG lost per year was added, that of simulation 1 became higher and both the two simulations have the same energy consumption of

References

- 1) Christensen, D. L. (2009). Gas Dehydration: Thermodynamic Simulation of Water/Glycol Mixture. Aalborg University Esbjerg, Page 1-15
- 2) James, G. and Speight, A. (2017). Deep Shale Oil and Gas. Published by Gulf Professional. Page 492, ISBN 9780128030981
- 3) Anyadiegwu, C., Kerunwa, A. and Oviawe, P. (2014). Natural Gas

1.143×10^5 KJ/h which shows that the new equipment added does not affect the energy consumption.

Conclusion

The following conclusion can be drawn from this work:

1. The concentration of TEG used for dehydration can affect its absorption efficiency.
2. The flow rate of the TEG used can affect the water content in the dry gas therefore affecting its transportation ability to region of temperature not below the hydrate formation temperature.
3. The pressure of TEG to wet gas can also affect the absorption efficiency i.e the pressure of TEG must be greater or equal to the wet gas for effective absorption.
4. Comparing the results obtained from the two simulations, it shows that using a recovery separator, still column with reboiler and reflux condenser will help achieve more pure TEG than using a still column with only a reboiler.
5. Increasing the reflux also reduces glycol loss but increases the duty of the reboiler and the traffic loads in the still column.

Dehydration Using Triethylene Glycol (Teg), Department of Petroleum Engineering, Federal University of Technology, Owerri, Nigeria, Published by Petroleum and Coal ISSN 1337-7027 Available online at www.vurup.sk/petroleum-coal

- 4) Kohl A., Arthur L., Fred C. (1985). Gas Purification (4th edition), Gulf Publishing Company, Houston, London

- 5) Ahmad, S. and Mohamad, B. (2009). "Natural Gas Dehydration using Triethylene Glycol (TEG)", Publication of the University of Malaysia Pahang, April.
- 6) Guo and Ghalambor (2005); "Natural Gas Engineering Handbook", Gulf Publishing Company, Houston Texas, USA.
- 7) Guo, B., Lyons, W.C., and Ghalambor, A. (2007): "Petroleum Production Engineering: A computer Assisted Approach" Elsevier Science & Technology Books.
- 8) H.K Abdel Aal, Mohamed Eggour and M. A. Fahim (2003); "Petroleum and gas field processing", Marcel Dekker Inc., New York, Basel.
- 9) Siti, N. and Abdul G. (2012). Simulation of Typical Natural Gas Dehydration Unit using Glycol Solutions. Engineering Reports 8 (2): 27-31
- 10) Offshore Book (2008). An introduction to the offshore industry; Offshore Center Danmark Publication Page 12-14.
- 11) <https://www.sciencedirect.com/topics/engineering/glycol-dehydration-process>. Accessed 23rd August 2021
- 12) <https://www.croftsystems.net/oil-gas-blog/why-should-you-dehydrate-natural-gas>. Accessed 24th August 2021.
- 13) <https://www.google.com/search?q=wet+gas+composition>. Accessed 26th August 2021