

Noninductive Control of Permanent Magnet Synchronous Motor Based on Improved Synovial Observer

ABSTRACT

In the non-inductive control of permanent magnet synchronous motor, the rotor position information of the motor is usually estimated by the synovial film observer. Synovial observer has the advantages of simple control structure and short response time. The switch function of the control process of the synovial observer is usually the sign function. The back electromotive force signal is extracted by the filter, and then the rotor position information is estimated by the inverse tangent method. However, the traditional switching process of sign function contains a large number of high order harmonics, which will cause the problems of phase difference and amplitude attenuation after the signal is filtered by the filter, and the estimation error of arctangent method is large. Based on the above problems, the traditional switching function is improved in this paper. Continuous sigmoid function is used as the switching function, which can effectively solve the problem of excessive vibration during the operation of the motor. In addition, phase-locked loop technology is introduced to replace the traditional inverse tangential method for rotor position estimation, which further improves the estimation accuracy of the system.

Keywords: Permanent magnet synchronous motor; synovial control; sigmoid function; phase locked loop.

1. INTRODUCTION

Permanent magnet synchronous (PMSM) motor has the advantages of small volume, large overload capacity and high efficiency [1-2], and has been widely used in various high-tech and daily life products. The control strategy of the motor is the key factor to improve the performance of the motor [3]. At present, the most important control mode of permanent magnet synchronous motor is vector control [4], which makes the motor output stable and efficient torque by precisely controlling the direction and size of the motor magnetic field [5]. In the vector control process of PMSM, the position and speed information of the motor rotor needs to be measured in real time, and various mechanical position sensors are usually used to collect relevant information [6]. However, the use of traditional mechanical position sensor will bring many problems, such as the system cost greatly increased, reliability reduced, precision decreased [7-8]. Based on these problems, the sensorless control technology of permanent magnet synchronous motor emerges as The Times require. By designing the motor controller

and power electronics, it can directly measure the motor winding current, electromotive force and other physical quantities, thus obtaining the rotor position and speed information and directly avoiding the use of traditional mechanical position sensors [9-10]. At present, there are various non-inductive control strategies and methods for permanent magnet synchronous motors. The sliding mode observer has become a popular non-inductive control method for permanent magnet synchronous motors due to its simple algorithm, easy implementation and strong robustness [11-12].

2. TRADITIONAL SYNOVIAL OBSERVER ALGORITHM

2.1 Design of Traditional Synovial Observer

Traditional synoval control is mostly designed based on mathematical model in coordinate system [13]. This paper focuses on the study of built-in permanent magnet synchronous motor, whose inductance of equivalent direct axis and

alternating axis is not equal [14], and its voltage equation in coordinate system can be given as follows:

$$\begin{bmatrix} u_\alpha \\ u_\beta \end{bmatrix} = \begin{bmatrix} R + \rho L_d & \omega(L_d - L_q) \\ \omega(L_d - L_q) & R + \rho L_d \end{bmatrix} \begin{bmatrix} i_\alpha \\ i_\beta \end{bmatrix} + \begin{bmatrix} E_\alpha \\ E_\beta \end{bmatrix} \quad (1)$$

When the switch function is a sign function, the values of the back electromotive force E_α and E_β of the traditional synovial algorithm are:

$$\begin{bmatrix} E_\alpha \\ E_\beta \end{bmatrix} = \begin{bmatrix} e_\alpha \\ e_\beta \end{bmatrix} = K \begin{bmatrix} \text{sgn}(\tilde{i}_\alpha) \\ \text{sgn}(\tilde{i}_\beta) \end{bmatrix} \quad (2)$$

2.2 Traditional Synovial Rotor Position and Velocity Estimation

After obtaining the back electromotive force value of the motor through the synovial observer, since the traditional sign function is a discontinuous high frequency switching signal, it is necessary to use a low-pass filter to process the estimated back electromotive force value:

$$\begin{bmatrix} \hat{E}_\alpha \\ \hat{E}_\beta \end{bmatrix} = \frac{\omega_0}{s + \omega_0} \begin{bmatrix} E_\alpha \\ E_\beta \end{bmatrix} \quad (3)$$

Where, ω_0 , \hat{E}_α and \hat{E}_β are the estimated cut off frequency and $\alpha\beta$ component of back electromotive force of the low-pass filter respectively.

After the filter processing, the arctangent method is usually used to extract the rotor position information, and the estimation process is as follows:

$$\hat{\theta}_e = -\arctan \frac{\hat{E}_\alpha}{\hat{E}_\beta} + \arctan \left(\frac{\hat{\omega}_e}{\omega_0} \right) \quad (4)$$

Where, $\hat{\theta}_e$ is the estimated angular velocity; $\hat{\omega}_e$ is the estimated angular velocity. The second half of the formula is composed of position compensation for phase delay caused by the use of a low-pass filter [15].

3. IMPROVE THE SYNOVIAL OBSERVER ALGORITHM

3.1 Improvement of Switching Function

The switching function used in the traditional synovial observer is the sign function of the symbol mutation, and its value jumps back and

forth between ± 1 . There are a large number of high harmonics in the system, and the synovial control generates large jitter. In order to reduce the serious problem of bucket vibration in the system, a continuous function $\text{sigmoid}(s)$ is introduced as a switching function, and its expression is as follows:

$$\text{sigmoid}(s) = \frac{2}{1 + \exp(-as)} - 1 \quad (5)$$

$\text{sigmoid}(s)$ is a continuous function, and its curve change is related to its value. The larger the value, the closer the function image will be to the sign function, and the smaller the value, the smoother the function image will be. In this case, the smaller the system shake matrix will be.

3.2 Phase-locked Loop Method Replaces Arc-tangent Method

In the traditional synovium control, filtering the back electromotive force with low pass filter will cause the phase difference and amplitude attenuation of the system, and then the inverse tangent method will further increase the error, because of the strong buffeting of the motor system.

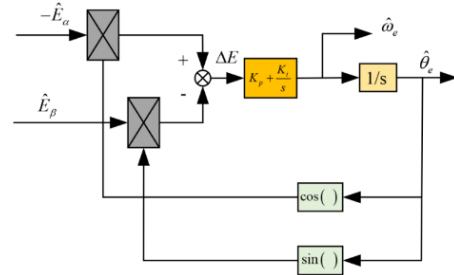

Fig. 1. Traditional PLL structure

When the error of $\hat{\theta}_e$ and θ_e is small enough, $\sin(\theta_e - \hat{\theta}_e) = \theta_e - \hat{\theta}_e$ can be considered. At this time, it can be inferred from the figure above:

$$\begin{aligned} \Delta E &= \hat{E}_\alpha \cos \hat{\theta}_e - \hat{E}_\beta \sin \hat{\theta}_e \\ &\approx k(\theta_e - \hat{\theta}_e) \end{aligned} \quad (6)$$

Where $k = (L_d - L_q)(\omega_e i_d - \rho i_\alpha) + \hat{\omega}_e \psi_f$. In this case, the equivalent of the phase-locked loop is:

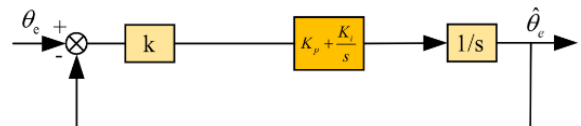

Fig. 2. Equivalent block diagram of phase-locked loop

4. ESTABLISHMENT OF SYSTEM SIMULATION MODEL AND ANALYSIS OF SIMULATION RESULTS

According to the above theories, the $i_d = 0$ vector control simulation model of the built-in permanent magnet synchronous motor based on the synovial control is built by Matlab/Simulink platform. The simulation model is shown in Fig. 1.

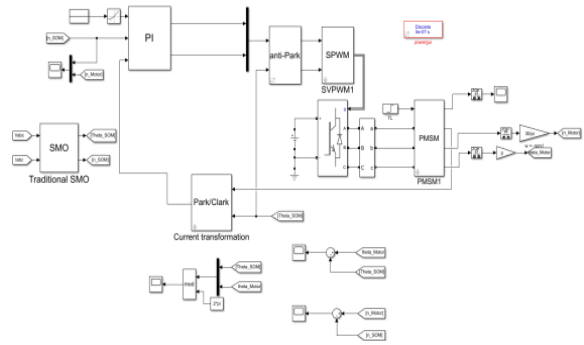

Fig. 3. Simulation model

The motor speed controlled by traditional synovial film and improved synovial film are shown in Fig. 4 and Fig. 5.

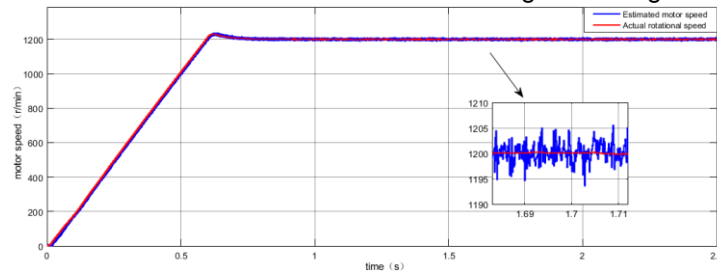

Fig. 4. Traditional synovial motorspeed diagram

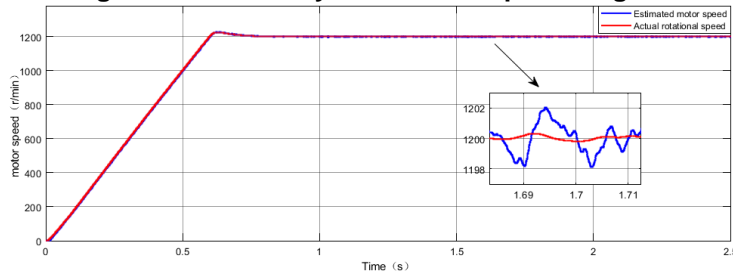

Fig. 5. Speed diagram of improved synovial motor

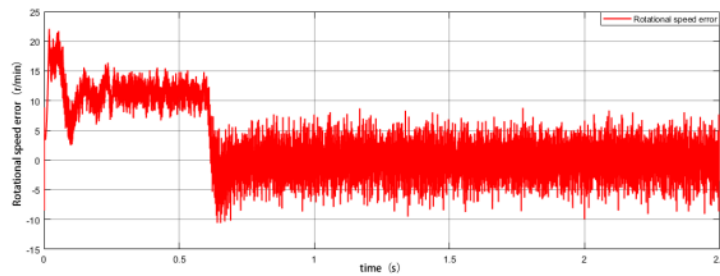

Fig. 6. Traditional synovial speed error

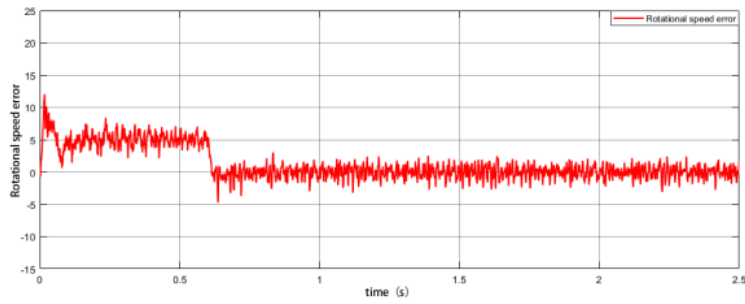

Fig. 7. Improved synovial speed error

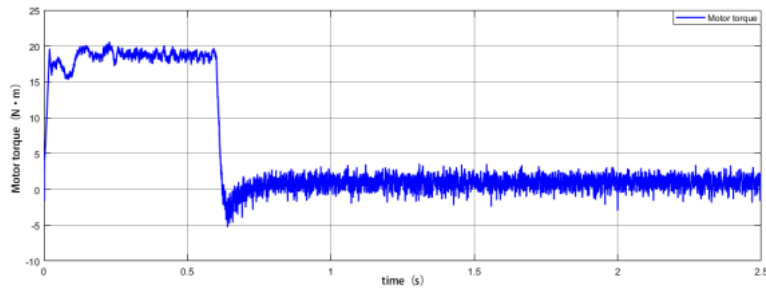

Fig. 8. Traditional synovial torque diagram

The motor speed errors controlled by traditional synovial film and improved synovial film are shown in Fig. 6 and Fig. 7.

Motor torques controlled by conventional and improved synovium are shown in Fig. 8 and Fig. 9.

The rotor positions of the motor controlled by conventional and improved synovium are shown in Fig. 10 and Fig. 11.

As can be seen from the motor speed diagram in Fig. 4 and Fig. 5, the motor speed controlled by traditional synovial film fluctuates greatly in the steady-state operation stage of the motor, ranging from 1195rpm to 1205rpm, while the motor speed controlled by improved synovial film fluctuates less, ranging from 1198rpm to 1203rpm. As can be seen from the speed error diagram in Fig. 6 and Fig. 7, the error of the motor in the starting stage of the traditional

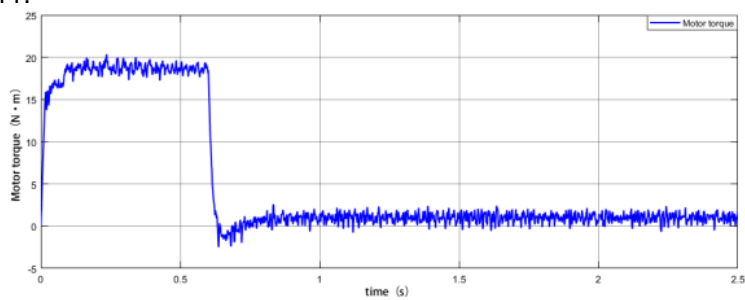

Fig. 9. Improved synovial torque

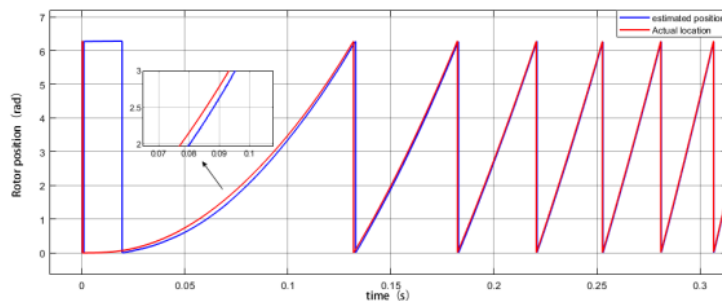

Fig. 10. Position of conventional synovial rotor

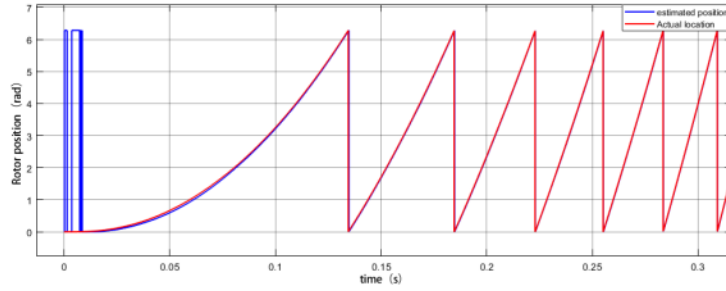

Fig. 11. Position of improved synovial rotor

synovial film is about 23rpm, and the error of the motor in the stable operation is about ± 7 rpm, while the error of the motor in the starting stage of the improved synovial film is about 13rpm. After stable operation of the motor, the error is between ± 2.5 rpm. As can be seen from the motor torque diagram in Fig. 8 and Fig. 9, the chattering of the motor is effectively reduced by the improved synovial film. The traditional synovial film is unstable in the starting stage, which is reflected in the large fluctuation of the motor torque, while the motor torque rises steadily in the starting stage of the improved synovial film. In the motor stability stage, the torque pattern of the improved synovial film is smaller and more stable than that of the traditional synovial film. It can be seen from the motor rotor position diagram in Fig. 10 and Fig. 11 that the two algorithms estimate the rotor position accurately with minimal error, and the improved synovial film can track the motor rotor position more quickly and accurately in the early stage.

To sum up, the overall control effect of the improved synovial film is better, and the position and speed information of the rotor can be estimated better, so as to achieve good control of the motor.

5. CONCLUSION

In this paper, by improving the Traditional synovial observer, sigmoid function was adopted as the switching function instead of sign function, and phase-locked loop technology was introduced to replace the traditional arctangent method to estimate the rotor position of the motor. Finally, the model of the two algorithms was built on the Matlab/Simulink simulation platform, and the simulation results were compared and analyzed. The results show that the chattering problem of the system can be

effectively reduced by the improved synovium control, the accuracy of position estimation of the motor rotor is improved, and the improved synovium has better performance.

COMPETING INTERESTS

Author has declared that no competing interests exist.

REFERENCES

1. Jin Baolong. Research on energy saving control system of permanent magnet synchronous motor [D]. Jiangnan University; 2017.
2. Bai Jianyong, Liu Yujia. PMSM Sensorless model predictive current control based on MRAS observer [J]. New Industrialization. 2015;5(09):52-58.
3. Xie Yuchun. Research on control strategy of AC permanent magnet synchronous motor servo system [D]. Harbin Institute of Technology; 2011.
4. Wang Fangkaiwen. Sensorless permanent magnet synchronous motor speed range with compound control strategy research [D]. Jiangxi University of Science and Technology; 2022.
5. Li Zhigang, Guo Hang, Zhu Yuehua. Application of low speed and high torque permanent magnet direct drive system in ball mill in thermal power plant [J]. Shanxi Electric Power. 2018(01):52-57.
6. The king of qin yu. No beat permanent magnet synchronous motor vector control research [D]. Hebei University of Engineering; 2020.
7. Li Tianyang, Zeng Yongjie, Zeng Xiaohua, Tian Yanrong, Chen Hongxu. All-digital fuzzy sensorless control system based on UKF study [J]. Journal of New Industrialization. 2021;(7): 211-215.

8. Yang Jianwei. Research on fault diagnosis and sensorless control of five-phase permanent magnet synchronous motor under the influence of interturn Short Circuit [D]. Northwestern Polytechnical University; 2018.
9. Tang Chunmao. Research on permanent magnet synchronous motor vector control system based on position estimation of sliding mode observer [D]. Chongqing University of Posts and Telecommunications; 2018.
10. Zhang Hongpeng. Research on sensorless control strategy of permanent magnet motor based on pseudo-random pulse injection [D]. Harbin Industrial University; 2020.
11. Tian Yaan, Xia Kun. Research on model predictive current control of permanent magnet synchronous motor based on sliding mode observer [J]. Mechanical and Electrical Engineering. 2017;34(10):1162-1167.
12. Peng Qiuming. Application of active disturbance rejection control technology in permanent magnet synchronous motor speed control system [D]. University of Science and Technology of China; 2018.
13. Bai A Wei, Jiang Chunxia. Sensorless control of permanent magnet synchronous motor based on sliding mode observer [J]. Science & Technology Innovation and Application. 2019(26):69-70. (in Chinese)
14. He Xianzhang. Weak magnetic speed permanent magnet synchronous motor control research [D]. Tianjin University of Science and Technology.
15. Dong Bowen. Built-in permanent magnet synchronous motor speed domain sensorless control strategy research [D]. China Mining University; 2022.