Fast-slow Dynamical Analysis in Harmonic Gear Transmission System with Non-smooth Gear Clearance Condition

ABSTRACT

Harmonic gear reducer is a new type of mechanical transmission device, which has the advantages of simple structure, small size, high precision, large transmission ratio, and high transmission efficiency, which cannot be realized by ordinary gear transmission devices. Due to the presence of various nonlinear factors in the harmonic gear reducer system, it often exhibits relatively complex dynamical behaviors, which has an adverse effect on the transmission accuracy and transmission efficiency of the system. There are many non-smooth factors in the transmission system, and gear clearance, as one of the common non-smooth factors in the harmonic gear transmission system, has made it difficult to control the relationship between the output angular displacement and the input angular displacement of the system, which reduces the stability and transmission accuracy. Therefore, we establish the dynamics model of the non-smooth harmonic gear transmission system, based on the fast-slow dynamical knowledge and numerical simulation, and analyze the dynamical behaviors of the system under this non-smooth factor. The research shows that when the value of the gear clearance is in a definite zone, the change of the value of the gear clearance will only quantitatively change the dynamic characteristics of the system, but not fundamentally change the motion characteristics of the system. When a smaller torsional stiffness coefficient is adopted, the vibration frequency of the dynamic error response of the system increases obviously, but the corresponding vibration amplitude does not change to a significant extent, which shows that the appropriate torsional stiffness can improve the dynamic response of the system and enhance the ability of the system to absorb external disturbances and resist shocks. In order to make the harmonic reducer satisfy more application situations, the evolution of the dynamical behavior of the system under different external excitations is investigated. When the system is under a light load, it works as a bilateral shock condition. And when it is in the heavy load state, the system switches to the unilateral shock state, and the larger load moment leads to multiple vibration responses in the dynamic error trajectory of the system, which may lead to the phenomenon of speed

fluctuation at the output of the system.

Keywords: Harmonic gear reducer; Fast-slow dynamics; Gear Clearance; The non-smooth factor

UNDER PEER REVIEW

1. INTRODUCTION

Harmonic gear reducer, as a mechanical transmission device, is a new type of transmission technology invented due to the rapid development of aerospace technology^[1], and it is a major innovative application in the field of mechanical transmission^[2]. The harmonic gear reducer has the incomparable advantages of other reducers, such as compact size, small volume, lightweight, low noise, smooth movement, small meshing clearance, high transmission precision, and high transmission efficiency^[3], especially for torque transmission to narrow and closed spaces and power^[4], so harmonic gear transmission technology has attracted great attention from various countries since its birth^[5].

The dynamic characteristics of the harmonic gear reducer system are very complex, and there are many nonlinear factors and multi-scale coupling effects^[6]. Meanwhile, the working conditions of the harmonic gear reducer are complex and changeable in the process of operation and the stability of each component is very important for the safe and efficient operation of the whole equipment^[7]. However, the current mainstream research focuses on the source analysis, basic properties, and their influence on the transmission performance of the specific nonlinear factors in the harmonic gear transmission system, and establishes the model of the specific factors^[8]. Using the knowledge of nonlinear dynamics to solve the problem of anti-vibration and noise reduction in the process of gear transmission has become an important topic that scholars at home and abroad have generally paid attention to. Some scholars have used the multi-scale method to analyze the single-degree-of-freedom gear vibration model and analyzed the dynamic response of the gear-tooth system under different conditions^[9]. But there are multiple coupling effects on different time scales in the harmonic gear transmission system, and there are few reports on the dynamics of the harmonic gear transmission system from the perspective of multi-scale. Therefore, the mathematical model established to analyze the harmonic gear transmission system must fully consider the scale effect under the actual background conditions, conduct qualitative and quantitative descriptions from a multi-scale perspective, establish a reasonable dynamic model, and more accurately reveal the mystery of the real model.

The non-smooth factor is an important nonlinear factor in the mechanical transmission system, and the harmonic gear transmission system is no exception^[10]. Non-smooth dynamic systems cover most of the models in the engineering field^[11]. Because these factors do not have continuous smoothness in the

mathematical sense, smooth dynamics cannot be used to solve problems in non-smooth systems, and special theoretical knowledge needs to be utilized and developed^[12]. Non-smooth factors may cause speed fluctuations and instantaneous transmission ratio imbalances in the harmonic gear transmission system, which hinders the accuracy and stability of the system^[13]. In recent years, with the development of the field of linear science, a large number of scholars have carried out a lot of research on the dynamical system with non-smooth factors from engineering applications and combined non-smooth factors with dynamics to reveal its dynamical mechanism^[14]. Therefore, it is very important to use the theory of non-smooth subjects to study the harmonic gear transmission system, which has important guiding significance for manufacturing and dynamic optimization design, and solving problems such as system stability, durability, and noise reduction^[15].

As one of the common non-smooth factors in the harmonic gear transmission system, the gear clearance will cause the relationship between the angular displacement of the output end and the angular displacement of the input end of the harmonic gear transmission system to be nonlinear, which seriously affects the transmission accuracy of the system^[16]. Due to the unique structure and complex transmission principle of the harmonic gear reducer itself, there are non-smooth factors that cannot be ignored^[17]. These factors will not only reduce the ideal transmission accuracy of harmonic gears but also affect the service life and operating quality of the final product^[18]. Therefore, the research on the non-smooth characteristics has extremely high research value, which can provide some theoretical basis for the design and application of harmonic gear reducers^[19].

At present, there are relatively few studies on the non-smooth multi-scale coupling effect in the harmonic gear transmission system, so the analysis of the fast and slow oscillation behavior in the system has important significance for the theoretical framework of non-smooth multi-scale dynamics and practical engineering applications^[20]. Based on the theory of non-smooth dynamics, this paper introduces a non-linear segmented gear clearance nonlinear function to study the influence of gear clearance in the process of harmonic gear transmission. First, we establish the dynamical equations of the non-smooth harmonic gear reducer system. Under the external periodic stimulation, we study the complex dynamic behavior in the harmonic gear reducer system under different gear clearance conditions, and select appropriate parameters to reveal the system dynamical evolution process and its changing law.

2. Dynamical Modeling of Non-smooth Harmonic Gear Reducer System

2.1 Definition of Gear Clearance in Harmonic Gear

Since the transmission principle of the harmonic gear reducer is different from other gear systems, when performing the motion and torque transmitted from the motor end to the load output end, it is necessary to comprehensively consider how nonlinear factors including gear clearance affect the dynamical behavior of the system. In order to ensure the stability of the transmission performance, gear clearance must be reserved in the harmonic gear reducer system. If the gear clearance is too large, it will cause vibration and noise in the system, and in severe cases, the system will collapse; if the gear clearance is too small, it is easy to cause the gear teeth to be stuck and excessive wear, which will affect the service life. The definition and source of gear clearance in the harmonic gear system have been introduced above. Considering different loading conditions and actual scenarios, the model selection of gear clearance is also different.

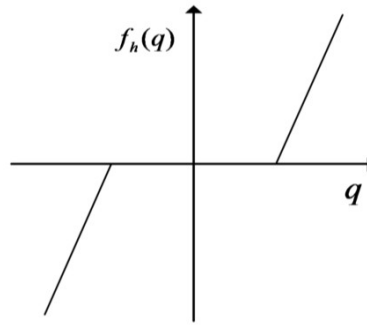

Fig. 1 Non-linear segmented functions of the gear gap clearance $f_h(q)$.

In order to facilitate the calculation and have the non-smooth characteristics of the gear clearance, this paper adopts the gear gap clearance model shown in Fig. 1. Let the gear clearance in the harmonic gear reducer be $2\varphi_i$, which is represented by a non-linear segmented gear clearance nonlinear function $f_h(\theta)$. The specific equation is as follows:

$$f_h(\theta) = \begin{cases} \theta - \varphi_i & \theta > \varphi_i \\ 0 & -\varphi_i < \theta < \varphi_i \\ \theta + \varphi_i & \theta < -\varphi_i \end{cases} \quad (1)$$

Where φ_i is the gear gap clearance. It can be measured experimentally: $\theta = \theta_o - \theta_i / N$, where θ_o is the output axis angular displacement and θ_i is the input axis angular displacement.

2.2 Dynamical model of harmonic gear reducer

The various behaviors of the gear transmission process in practical engineering applications are extremely complex. We assume that the gears, transmission shafts and constraints are rigid in the axial direction without deformation, and establish the harmonic gear transmission system model including nonlinear factors such as transmission error, stiffness, damping, and gearclearance, as shown in Fig. 2. In Fig. 2, J_i and J_o are the moment of inertia of the input end and the load end respectively, θ_i and θ_o are the angular displacement of the motor input end and the output end of the load end respectively, T_{im} is the static average moment of the input shaft, T_{om} is the harmonic gear flexspline output torque, N is the reduction ratio, $K(\theta)$ is the nonlinear torsional stiffness, and C_{eq} is the equivalent damping coefficient of the system.

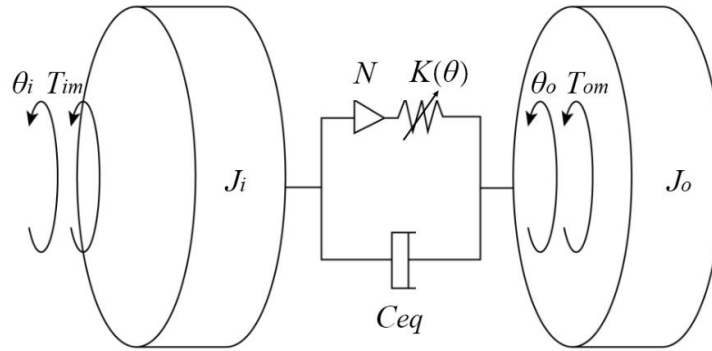

Fig. 2 Simplified model of the harmonic gear system.

According to the mechanical relationship of the harmonic gear transmission system, the following differential equation of motion can be obtained:

$$\begin{aligned} J_o \ddot{\theta}_o + C_{eq} (\dot{\theta}_o - \dot{\theta}_i / N) + K(\theta) f(\theta) &= T_{om} \\ J_i \ddot{\theta}_i - C_{eq} (\dot{\theta}_o - \dot{\theta}_i / N) / N - K(\theta) f(\theta) / N &= -T_{im} / N \end{aligned} \quad (2)$$

The friction behavior in the harmonic gear transmission system is very complex. For the convenience of analysis, here we use the equivalent damping coefficient C_{eq} to approximate the friction factors in the system, namely:

$$C_{eq} = 2\xi \sqrt{J_{eq} K_{HD}} \quad (3)$$

Where ξ is the damping ratio, $J_{eq} = N^2 J_i J_o / (N^2 J_i + J_o)$ is the equivalent torsional inertia of the system, and K_{HD} is the average stiffness of the gear mesh.

The nonlinear stiffness $K(\theta)$ is an important nonlinear factor of the system, which is affected by gear meshing and flexible bearings. In this paper, the nonlinear stiffness form given in [6] is adopted, as follows:

$$K(\theta) = k_1 + k_2\theta^2 \quad (4)$$

Among them, k_1 and k_2 are torsional stiffness coefficients, $\theta = \theta_o - \theta_i / N$ is the relative twist angle, and the meanings of θ_i , θ_o and N are the same as above.

In this paper, it is assumed that the output torque T_{om} of the harmonic gear flexspline is affected by the periodic slow disturbance, which can be expressed in the form of $T_{om} = T_{fs} + T_{am} \sin(\omega t)$, where $T_{fs} = T_{im}$, $0 < \omega \ll 1$. Therefore, the original four-dimensional nonlinear system (2) can be simplified into a two-dimensional nonlinear system (5):

$$J_{eq} \ddot{\theta} + C_{eq} \dot{\theta} + K(\theta) f_h(\theta) = T_m + J_{eq} T_{am} \sin(\omega t_0) / J_o \quad (5)$$

Carry out dimensionless processing on system (5), set the system to solve from zero, then $x = (\theta - \theta_r) / \theta_s$, $D = \varphi / \theta_s$, $t = t_0 / t_s$, and the dimensionless dynamical model can be obtained:

$$\ddot{x} + \dot{x} + x^2 f(x) + Af(x) = B + C \sin(\omega_o t) \quad (6)$$

Where $A = k_1 k_2 J_{eq}^2 / C_{eq}^4$, $B = k_2 J_{eq}^2 T_m / C_{eq}^4$, $C = k_2 J_{eq}^3 T_{am} / C_{eq}^4 J_o$, $\omega_o = \omega J_{eq} / C_{eq}$. The dimensionless gear clearance function in the formula is

$$f(x) = \begin{cases} x - D & x > D \\ 0 & -D < x < D \\ x + D & x < -D \end{cases} \quad (7)$$

Equation (6) contains differential equations of motion for piecewise non-smooth gear backlash (1) and time-varying torsional stiffness (4), and the non-smooth gear clearance with two interfaces divides the whole system into three subregions S_1 , S_2 and S_3 .

3. Fast-slow Dynamical Analysis of Harmonic Gear Reducer System

When the external excitation response frequency ω and the internal natural frequency of the autonomous system involve a magnitude difference in the frequency domain, the system will have a multi-scale coupling effect, which may produce complex dynamical behaviors, and usually manifest as fast-slow oscillations that alternately evolve from small-amplitude oscillations to large-amplitude

oscillations. In the following, we analyze the dynamical characteristics of the system with different system parameters as variables.

3.1 Changes in Gear Gap Clearance

The vibration behavior of the harmonic gear reducer system is affected by the gear clearance between the internal teeth of the flex spline and the external teeth of the rigid spline, and the dynamical characteristics of the system also change with the change of the gear clearance. As shown in Fig. 3, we fixed the other parameters of the system as $J_i = 6.8 \times 10^{-4}$, $J_o = 2.4 \times 10^{-2}$, $N = 100$, $\xi = 0.05$, $K_{HD} = 7200$, $k_1 = 3000$, $k_2 = 21000$, $\varphi = 1.75 \times 10^{-2}$, $T_m = 10$ and $T_{om} = 15$, and set the values of the dimensionless gear clearance to $D = 0.1$, $D = 0.25$, $D = 0.5$ respectively to analyze the evolution of the dynamical characteristics of the system.

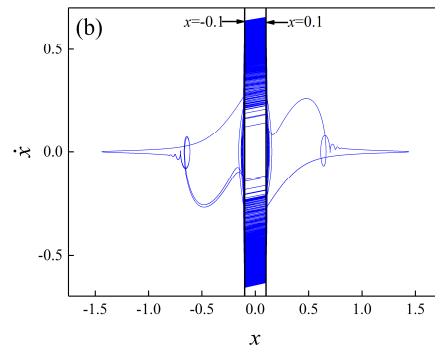
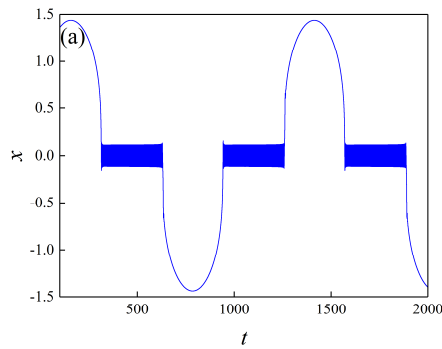

$D = 0.1$

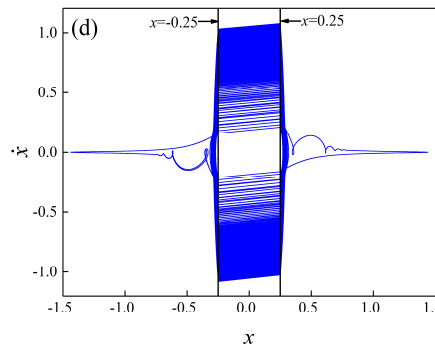
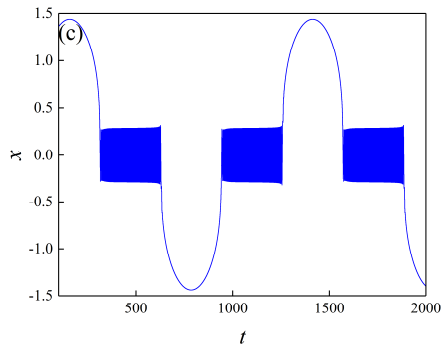

$D = 0.25$

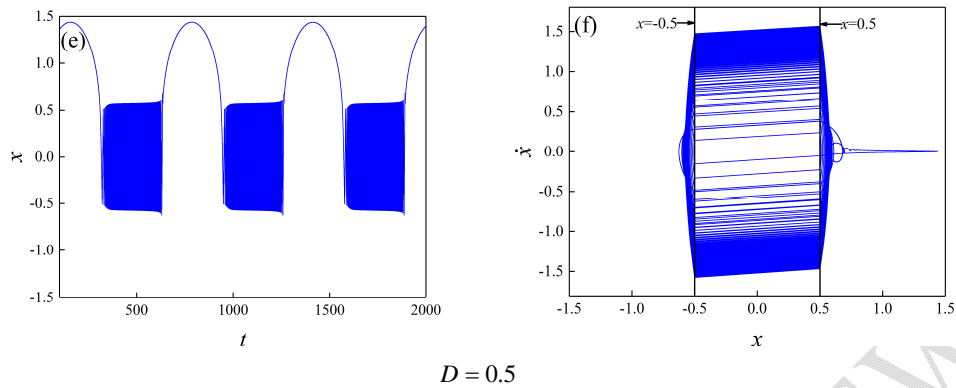

Fig. 3 The dynamical oscillations of the system when there are different gap clearances.

Through the time series diagram, it can be found that when the gear clearance of the system increases from 0.1 to 0.5, the harmonic gear reducer system will show obvious non-smooth characteristics and nonlinear characteristics, which means that the system has complex dynamical behaviors at this time. When the gear clearance is at $D = 0.1$ or $D = 0.25$, it can be observed from the time series diagram that the gear teeth of the harmonic gear reducer system are in the motion state of bilateral impact. And when the gear clearance is at $D = 0.5$, the gear teeth of the system are transformed into a state of unilateral impact, and the corresponding phase diagram is asymmetric at this time. Continue to increase the gear clearance, but the overall dynamical characteristics of the system will not change qualitatively, and the gear teeth will always be in the form of unilateral impact.

The impact of the change of the gear clearance value on the system is mainly manifested in the transition of the motion state of the gear teeth between the unilateral impact state and the bilateral impact state. Therefore, when the gear clearance value of the system is within a reasonable range, the dynamical characteristics of the harmonic gear reducer system will not change fundamentally, and the magnitude of the corresponding response change will not be too large.

3.2 Changes in Torsional Stiffness

The torsional stiffness curve expression of the harmonic gear reducer system in the forward loading process is system (4). This section focuses on the torsional stiffness coefficient related to the physical characteristics of the system itself and explores the influence of changes in the torsional stiffness coefficient on the system's dynamic behavior. Next, we fix the gear clearance of the system to

$D = 0.1$, while keeping other parameters in the system constant except torsional stiffness, only changing the torsional stiffness of the system.

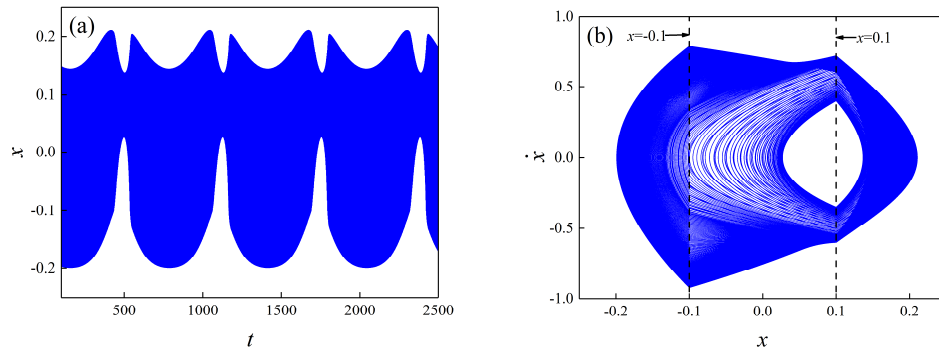

$k_1 = 1000$

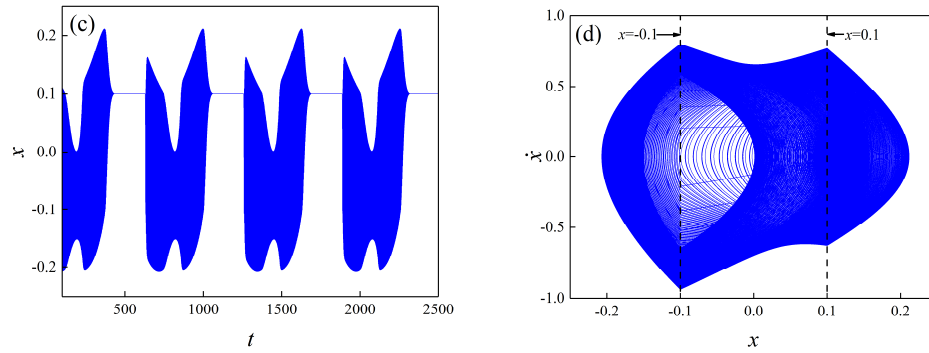

$k_1 = 3000$

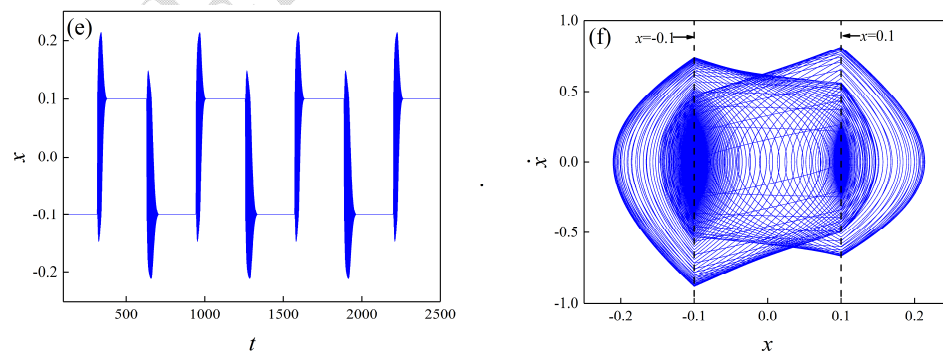

$k_1 = 7000$

Fig. 4 The dynamical oscillations of the system when there are different torsional stiffness coefficients.

Fig. 4 shows the time series diagram and related phase diagram of the corresponding harmonic gear reducer system when the corresponding torsional stiffness coefficient values are $k_1 = 1000$, $k_1 = 3000$, and $k_1 = 7000$. When the value of the torsional stiffness coefficient is smaller, the vibration frequency of the dynamical error of the system is faster, and the corresponding vibration amplitude changes little. Therefore, the change in the torsional stiffness coefficient will lead to a large change in the dynamic error response of the system, which will have a greater impact on the system, and a larger torsional stiffness coefficient can significantly improve the dynamical response of the system, enhance the system's ability to absorb external disturbances and resist impact capability.

3.3 Changes in External Excitation Response

In the actual engineering application background, the harmonic gear reducer system will bear different external load excitation responses to meet the needs of different scenarios. We fix other parameters in the system and set the response components of the external load excitation of the harmonic gear reducer system to $T_{am} = 10Nm$, $T_{am} = 50Nm$, and $T_{am} = 100Nm$ respectively, and the corresponding time series diagram and phase diagram of the system are shown in Fig.5.

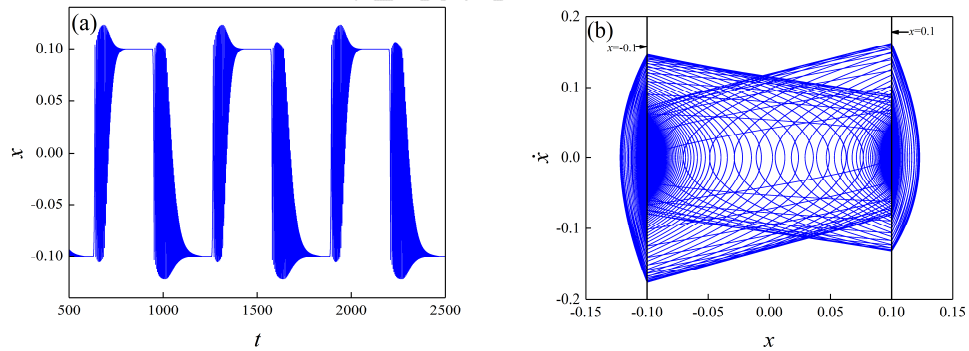

$$T_{am} = 10Nm$$

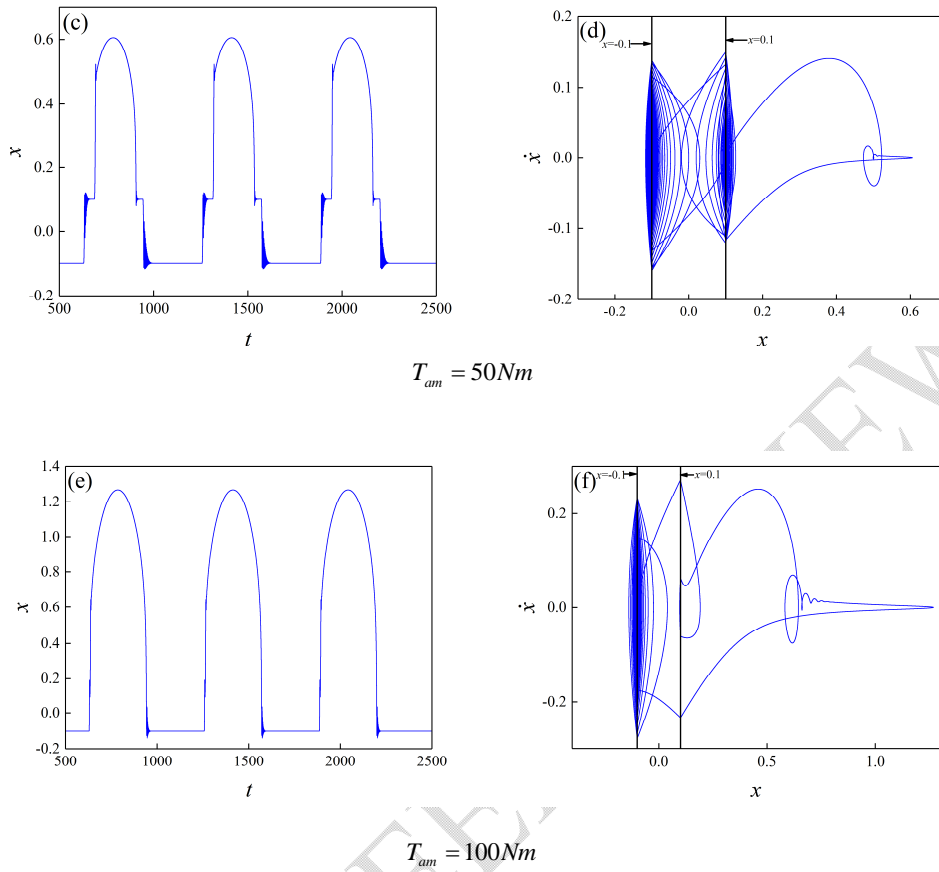

Fig. 5 The dynamical oscillations of the system when there are different external excitation responses.

When the external load excitation response component $T_{am} = 10Nm$, the output of the harmonic gear reducer system bears a relatively small load and is in a light load state, while the gear teeth are in a bilateral impact state. When $T_{am} = 50Nm$ and $T_{am} = 100Nm$, the system is in a heavy load state. At this time, the output end of the flexible spline is driving a large load end torque, and its external teeth and the internal teeth of the rigid spline are always in a meshing state, and the system switches to a single-side impact state. It is worth noting that when $T_{am} = 100Nm$, a high-frequency vibration response appears in the dynamical error response curve of the system.

Due to the increase of the external load excitation response component, the response amplitude of the system's dynamical error also increases, because the external disturbance component causes the error component amplitude to increase. At the same time, there will be speed fluctuations at the output end of the system, which will reduce the stability and accuracy of the output end of the system.

4. CONCLUSIONS

This article introduces the non-smooth factors of gear clearance in the harmonic gear reducer system and establishes a non-smooth harmonic gear dynamics model with two interfaces. Based on vibration theory and nonlinear dynamics theory, combined with time series diagram and phase diagram, the effects of different nonlinear factors on the dynamical behavior evolution process of the harmonic gear reducer system are studied.

When the gear clearance of the harmonic gear reducer system is within a small range, the corresponding operating state is a bilateral impact state, and the meshing state of the gear is about to be detached. As the size of the gear clearance increases, the system's motion state changes to a unilateral impact state. When the gear clearance value is in a reasonable and safe range, the change in the numerical value of the gear clearance only changes the dynamic characteristics of the system in quantity, without fundamentally changing the system's motion characteristics. When a smaller torsional stiffness coefficient is adopted, the vibration frequency of the dynamical error response of the system significantly increases while the amplitude of the vibration changes little. This indicates that appropriate torsional stiffness can significantly improve the dynamical response of the system, and increase the system's ability to absorb external interference and its shock resistance. Observing the dynamic behavior evolution of the system corresponding to different external load excitations in other usage scenarios of the harmonic gear reducer, it is found that the system is in a bilateral impact state under light-load conditions, and it switches to a unilateral impact state when under heavy-load conditions. A large negative load torque will result in multi-vibration responses of the dynamical error curve, which may cause a speed fluctuation phenomenon in the output end of the system.

The research results of this paper can provide ideas for the application of fast-slow dynamical analysis methods to solve the dynamic problems in the harmonic gear reducer system. On the other hand, it can provide a certain theoretical reference for improving the transmission accuracy and stability of the harmonic gear reducer.

REFERENCES

- [1] Ueura K, Slatter R. Development of the harmonic drive gear for space applications. European Space Agency-Publications-Esa SP, 1999, 438: 259-264.
- [2] Han Su Jeon, Se Hoon Oh. A study on stress and vibration analysis of a steel and hybrid flexspline

-
- for harmonic drive. *Composite Structures*, 1999, 47(1-4): 827-833.
- [3] Awasthi S K, Satankar R K. Analysis of Flexspline in the Harmonic Drive System: A Review. *International Journal of Engineering Sciences & Research Technology*, 2014, 3(6): 886-890.
- [4] Eugenia Minca and Adrian Filipescu and Alina Voda. Modelling and control of an assembly/disassembly mechatronics line served by mobile robot with manipulator. *Control Engineering Practice*, 2014, 31: 50-62.
- [5] Legnani G, Faglia R. Harmonic drive transmissions: the effects of their elasticity, clearance and irregularity on the dynamic behaviour of an actual SCARA robot. *Robotica*, 1992, 10(4): 369-375.
- [6] Godler I, Horiuchi M, Hashimoto M, et al. Accuracy improvement of built-in torque sensing for harmonic drives. *Mechatronics, IEEE/ASME Transactions on*, 2000, 5(4): 360-366.
- [7] Kennedy C W, Desai J P. Modeling and control of the Mitsubishi PA-10 robot arm harmonic drive system. *Mechatronics, IEEE/ASME Transactions on*, 2005, 10(3): 263-274.
- [8] Peles S, Wiesenfeld K. Synchronization law for a Van der Pol array. *Physical Review E*, 2003, 68(2): 026220.
- [9] Hei Mo, Zhou Qingkun, Liao Hongbo, et al. Modeling of harmonic drive system with low-frequency resonance[J]. *Key Engineering Materials*. 2014, 620: 424-430.
- [10] Dhaouadi R, Ghorbel F H, Gandhi P S. A new dynamic model of hysteresis in harmonic drives. *Transactions on Industrial Electronics*, 2003, 50(6): 1165-1171.
- [11] Rhéaume F., Champliaud H, Liu Z. Understanding and modelling the torsional stiffness of harmonic drives through finite-element method. *Mechanical Engineering Science*, 2009, 223(210): 515-524.
- [12] Zhang H, Ahmad S, Liu G. Modeling of Torsional Compliance and Hysteresis Behaviors in Harmonic Drives. *Transactions on Mechatronics*, 2015, 20(1): 178-185.
- [13] Vola D, Raous M, Martins J. A. C. Friction and instability of steady sliding: squeal of a rubber/glass contact. *International Journal for Numerical Methods in Engineering*, 1999, 46(10): 1699-1720.
- [14] Fathi H, Friedhelm A. On the kinematic Error in Harmonic Drive Gears. *Transactions of the ASME*, 2001, 123(1): 90-97.
- [15] Wei Li, Lian Jing Hao. Study on the degradation law of harmonic gear drive backlash with wear and assembly errors[J]. *Engineering Failure Analysis*, 2022, 140: 106614.
- [16] Rezaei M, Talebitooti R. Investigating the performance of tri-stable magneto piezoelectric absorber in simultaneous energy harvesting and vibration isolation. *Applied Mathematical Modelling*, 2022, 102: 661-693.
- [17] Lessard J, Bigras P, Liu Z, et al. Characterization, modeling and vibration control of a flexible joint for a robotic system. *Journal of Vibration & Control*, 2012, 20(6): 943-960.
- [18] Shi X L, Han Y, Wu J H, et al. An FFT-based Method for Analysis, Modeling and Identification of Kinematic Error in Harmonic Drives. *Intelligent Robotics and Applications 2019*, 11744: 191-202.
- [19] Yu Y, Wang Q Q, Bi Q S, et al. Multiple-S-Shaped Critical Manifold and Jump Phenomena in Low Frequency Forced Vibration with Amplitude Modulation. *International Journal of Bifurcation and*

Chaos, 2019, 29(5): 1930012.

- [20] Rinzel J, Lee Y S. Dissection of a model for neuronal parabolic bursting. *Journal of Mathematical Biology*, 1987, 25(6): 653-675.

UNDER PEER REVIEW