

THE SYSTEM OF MOTOR VEHICLE ENGINE RACING LIMIT CONTROL SYSTEM
BASED ON OIL CONDITION LEVEL BASED ON ATmega328 MICROCONTROLLER

ABSTRACT

Received:

Accepted:

Keywords:

Mikrokontroler

ATMega328,

Oil.

Research has been carried out for the manufacture of a motor vehicle engine speed limit controller based on the level of oil condition based on the ATmega328 microcontroller. The method used is to read the pressure at different temperatures and certain rotations, if the pressure is too low then the program will determine that the oil condition is bad or it is time to change it, when the oil or lubricant has been determined that the condition is bad then the indicator light will light up. and the maximum engine speed limit will be cut to 6000 rpm so that the engine will not be able to be used for rotations above 6000 rpm. Cutting the engine speed limit has the aim of preventing the engine from being forced to work at too high a speed when the oil is in bad condition so that the engine components will last longer, besides that the indicator also serves as a reminder that it is time for the vehicle to need an oil change.

1.INTRODUCTION

The importance of the role of transportation in providing access to goods and services that are essential for a person's life is getting more attention in the study of transportation. The general solution to improve public accessibility is to provide public transportation services, but in conditions of low public transportation services, private vehicle ownership is an unavoidable solution. In the use of motorized vehicles, it is necessary to carry out routine maintenance such as engine oil changes that must be done so that the motor vehicle engine works properly [11].

In terms of efficiency and effectiveness of motor vehicle engine performance, it is strongly influenced by the condition of the lubricant or oil used [5]. Oil that has been used at a certain time (based on mileage or working time) must also be replaced because the viscosity of the oil has generally changed (increasingly dilute) and over time the oil is used, the color of the oil will change [8].

In the description above, it is known that regular oil changes are needed because the worse the condition of the oil will have an impact on the wear of the engine components of the vehicle, but most people often forget to check or monitor the condition of the oil or lubricant in the motor vehicle used. This prompted the author to create a tool that can monitor the condition of the oil by giving a warning in the form of an LED, In addition to providing a reminder indicator for oil change times, this tool can also lower the engine speed limit so that the engine does not run at too high a speed so that the engine does not experience excessive friction when the oil or lubricant is in poor condition.

1.1 Engine Oil or Lubricants

Lubricant or oil is a chemical substance that has the general form of a liquid, which is given between two moving objects to reduce friction. This substance is a fraction of petroleum distillation which has a temperature of 105-135 degrees Celsius. Oil is also used in motor vehicles because the engine of a motorized vehicle always experiences friction in each of its components, the heavier the motor load the lower the value of the viscosity (thickness or internal friction) of the lubricant. One of the functions of lubricating oil is to lubricate moving parts of the engine to prevent wear and tear due to friction between two objects. Lubricating oil forms an oil film inside two moving objects so as to prevent friction or direct contact between the two rubbing objects [4].

1.2 Arduino Uno

Arduino is a microcontroller board based on the ATmega328 [16]. Arduino UNO contains everything needed to support the microcontroller, it's easy to connect it to a computer with a USB cable or supply it with an AC to DC adapter or use a battery to get started [12]. The ATmega328 on the Arduino Uno comes with a bootloader that allows to upload new code to the ATmega328 without using an external hardware programmer [13].

Arduino has 14 input/output pins of which 6 can be used as PWM outputs [6], 6 analog inputs, a 16 MHz crystal oscillator, a USB connection, a power jack, an ICSP header, and a reset button [2]. To change analog pins to digital, simply change the pin configuration in the program [14][9][17]. In this project, Arduino serves as a logic program operator that has been determined based on data that has been obtained through research. The arduino can be seen in Figure 1.



Figure 1 Drawing of Arduino uno.

1.3 RTD Thermocouple

RTD (Resistance Temperature Detector) is a temperature sensor whose measurement uses the principle of changes in resistance or metal electrical resistance which is affected by changes in temperature. The RTD is one of the most widely used temperature sensors in automation and process control.

The wire-wound element or standard type is usually made of corrosion-resistant wire wrapped around a ceramic or glass material, then covered with a probe casing as a protector. Between the RTD wire and the sheath there is also a ceramic (porcelain insulator) to prevent short circuits between the platinum wire and the protective sheath. The RTD temperature sensor that will be used can be seen in the following figure 2 [10].



figure 2 Thermocouple RDT PT100.

1.4 Pressure Sensor

This sensor has a transducer that measures wire tension, which converts the mechanical stress into an electrical signal. The basis of sensing is the change in the resistance of the conductor (transducer) which changes due to changes in the length and cross-sectional area [1].

1.5 Proximity Sensor

The proximity sensor is a sensor or switch that detects the presence of a target (type of metal) without physical contact. This sensor can be applied to sensing conditions on objects that are considered too small/soft to actuate a mechanical switch. The characteristics of this sensor is to detect objects at a fairly close distance, proximity sensors are classified into two types, namely Inductive Proximity Sensors and Capacitive Proximity Sensors.

Inductive Proximity Sensor or Inductive Proximity Sensor is a sensors used to detect the presence of metal, both ferrous and non-ferrous metals. These sensors can be used for detecting the presence

(presence or absence of metal objects), counting metal objects and positioning applications. For inductive proximity, it can be seen in Figure 3 [7].

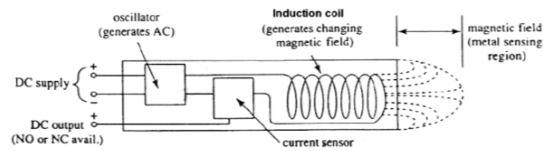

Figure 3 Drawing of Poximity Inductive Sensor Circuit.

Capacitive Proximity Sensor or **Capacitive Proximity Sensor is a sensor to detect motion**, chemical composition, level and composition of liquids and pressures. For capacitive proximity, it can be seen in Figure 4 [7].

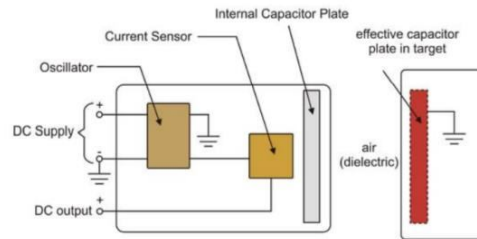

Figure 4 Image of Poximity Capacitive Sensor Circuit.

1.6 Relay

Relay is a switch which is controlled by electric current. Relays have a low-voltage coil wound around a core. Relays are needed in electronic circuits as executors as well as interfaces between loads and electronic control systems with different power supply systems. Physically, the switch or contactor with the relay electromagnet is separate, so that the load and control system are separate [18].

2. CIRCUIT

From the data and programs that have been made, the design of the tool can be carried out in accordance with the command program that has been given, the overall design of the tool starts from sensors, Arduino, indicators, and relays as engine speed limit cutter switches which can be seen in Figure 5.

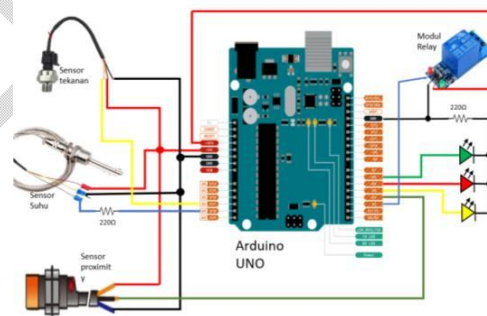

Figure 5 Arduino Circuit

In addition to the Arduino circuit, an adapter circuit is also needed so that a short circuit does not occur if there is a power surge from the voltage source. The adapter circuit can be seen in Figure 6.



Figure 6 Circuit adapter or power supply

3. RESULT AND DISCUSSION

3.1 Result

From the data that has been obtained through research regarding the difference in pressure conditions between new oil and oil that is time to be replaced based on different temperatures and engine speeds, Examples of pressure data that have been obtained at rotations of less than 2000 rpm can be seen in the table 1.

Table 1. oil pressure data 1

Engine Rotation Speed < 2000 rpm			
No.	temperature (°C)	Old Oil Pressure (Pa)	New Oil Pressure (Pa)
1	27,56	77800	141133
2	28,89	77800	141133
3	30,21	64466	124466
4	31,54	64466	121133
5	32,87	64466	112800
6	34,2	52800	104466
7	35,52	44466	97800
8	36,85	44466	94466
9	38,18	44466	86133
10	39,51	42800	82800
11	40,83	42800	81133
12	42,16	41133	77800
13	43,49	41133	77800
14	44,82	39466	71133
15	46,14	37800	66133
16	47,47	37800	64466
17	48,8	37800	62800
18	50,13	37800	61133
19	51,45	36133	59466
20	52,78	36133	59466
21	54,11	36133	56133
22	55,44	36133	54466
23	56,76	36133	49466
24	58,09	36133	49466
25	59,42	36133	49466
26	60,75	32800	47800
27	62,07	32800	46133
28	63,4	31133	41133
29	64,73	31133	41133
30	66,06	31133	41133
31	67,38	31133	41133
32	68,71	31133	39466
33	70,04	29466	39466
34	71,37	29466	37800

35	72,69	27800	37800
36	74,02	26133	36133
37	75,38	26133	36133
38	76,68	24466	34466
39	78	24466	31133
40	79,33	22800	31133
41	80,66	22800	31133

From the data above it can be said that the new oil pressure is always higher or different from the oil being replaced, this is because the oil to be replaced will have a lower viscosity value. The placement of the programmed tools can be seen in Figure 7 and positioning from the sensor can be seen in figure 8 to 10.



Figure 7 Electronic circuit placement



Figure 8 Potitioning of Thermocouple

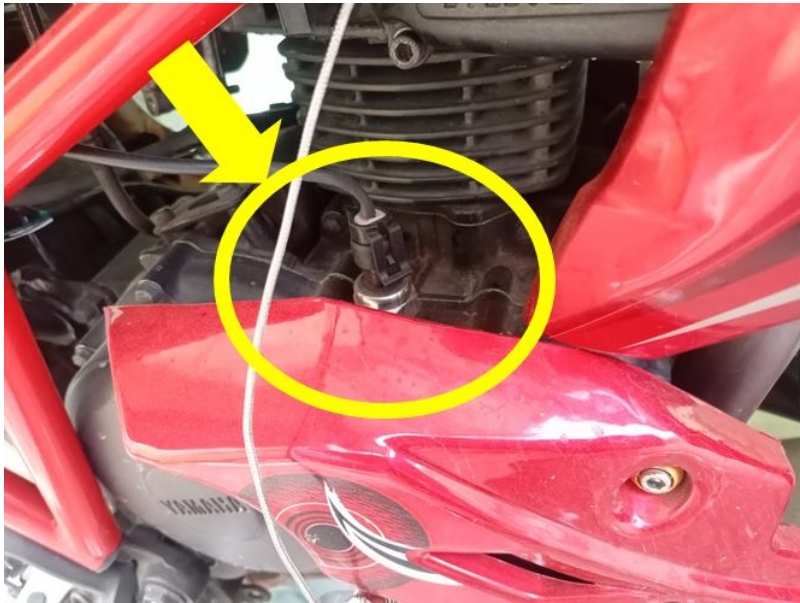

Figure 9 Potitioning of the Pressure Sensor

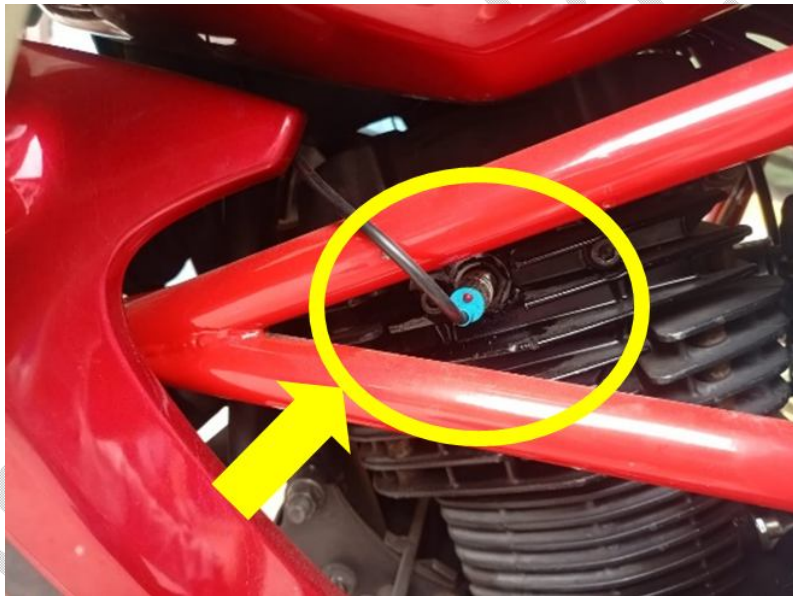

Figure 10 Potitioning of Proximity sensor

3.2 Discussion

The control program made has the logic that if the pressure at a certain speed and temperature is less than or equal to the pressure value recorded as oil which is time to be replaced, Arduino will instruct the relay to cut the engine speed limit so that it will make the engine unable to rotate with the rotation at the top speed. above 6000 rpm, this is intended so that the engine does not experience extreme friction when the oil is in bad condition.

In addition to cutting the engine speed limit, the system has been designed will display some information to the driver in the form of three indicator lights that have their respective meanings. The first indicator is a flashing amber light which means a warning that the temperature is still too low or the motor is not ready to be forced to an engine speed that is too high, so it is better to use the motor at a reasonable engine speed. The second indicator is that the yellow light is on continuously, which means the engine temperature is too hot so the motor is also better not to be forced to be at high engine speed because it will have an impact on engine component wear. The third indicator is a red light which means it's time to change the oil and limiting the engine speed limit is done so that the driver will not be able to force the engine to spin at high speeds, while the last indicator is a green light which means that everything is fine includes the ideal oil temperature and the condition of the oil is still good.

4. CONCLUSION

Oil that is bad or is about to be changed has a lower pressure than fresh oil. The pressure after the oil is used at a distance of 1000 km is the viscosity (viscosity) is decreasing and it can be shown by evidence that the pressure is reduced, because at the same flow velocity a liquid with a lower viscosity will exert a lower pressure than the liquid with higher viscosity.

This engine speed limit control system works by comparing the sensor readings with the recorded data, if the pressure at the engine speed and temperature is the same as the data but the pressure is below the bad oil data, Arduino will automatically cut the maximum engine speed from 10,000 rpm to 6,000 rpm.

References

- [1] Ahmad, F. 2018. Design of Air Pressure Measuring Instruments Using the MPX5700 Gauge Sensor Based on the ATmega328 (Arduino uno) microcontroller module. Final Project Report II, D-III Metrology and Instrumentation Study Program, FMIPA University of North Sumatra.
- [2] Akbar B., Alfian. 2017. Water Temperature Controller Using DS18B20 Sensor Based on ATmega328 (Arduino uno) microcontroller module. Final Project, D-III Physics Study Program, Faculty of Mathematics and Natural Sciences, University of North Sumatra.
- [3] Andawiyah, R. 2021. <https://warstek.com/akurasi-dan-presisi/>. [Accessed on the 13th November 2021].
- [4] Arisandi, M., Darmanto., Priangkoso, T. 2012. Analysis of the Effect of Lubricant Base Ingredients Against Lubricant Viscosity and Fuel Consumption. Momentum Journal. Vol. 8, No. 1:56-61.
- [5] Arnoldi, D. 2009. Selection of Lubricating Oil / Motor Vehicle Oil. Austenite Journal. Vol. 1, No. 2:26-30
- [6] Artawan, M, D., Gunawan, A. A. N., Sumadiyasa, M, 2018, Use of Short Message Service (SMS) Based ATmega328 Microcontroller and SIM800L Modules as on/off Control Electronic Equipments, Advances in Applied Physics, Vol.6 No. 1: 19-24.
- [7] Asrul, Sahidin, S., Alam, S., 2021, Automatic Hand Washing Machine Using Proximity Sensor and Mini Dfplayer Based on ATmega328 (Arduino uno) microcontroller module. Mosfet Journal, Vol. 1, No. 1:2775-5274.

- . Analysis of Lubricating Oil Quality Decline in Motor Vehicles Based on Viscosity Value, Color and Amount of Impurities. *Journal of Theory and Application of Physics*. Vol. 3, No. 2: 171-178.
- [9] Hanan, Gunawan, A. A. N., Sumadiyasa, M, 2019, Water Level Detection System Based on Ultrasonic Sensors HC-SR04 and ESP8266-12 Modules with Telegram and Buzzer Communication Media, *Instrumentation Measure Metrologie*, Vol. 18 No. 3: 305-309.
- [10] Hendarto, D., Taufik, F. I. 2015. Implementation of 4-20 mA Signal as a Variable Regulator Frequency Drive (VFD) Sensor Based RTD PT100. *Journal of Electrical Engineering and Science*. Vol. 2 No. 1: 1-7.
- [11] Herwangi, Yori., Sabri, I., Kustiwan, I. 2015. The Role and Pattern of Motorcycle Use in Low-Income Communities in Yogyakarta Urban Area. *Journal of Urban and Regional Planning*. Vol. 26, No. 3: 166-176.
- [12] Ichwan, M., Husada, M. G., Rasyid, A. M. I. Development of Control System Prototypes Electrical Equipment on the Android Platform. *Journal of Informatics*. Vol. 4, No. 1: 13-25.
- [13] Khaery, M, Gunawan, A. A. N., Paramarta, I. B. Alit, 2020, Water Flow Control System by Online Based on ATmega328P Microcontroller, *Contemporary Engineering Sciences*, Vol. 13 No. 1: 303-314.
- [14] Kunthi, Mahendy R., Gunawan, A. A. N., Ratini, N, 2020, Making Monitoring Device of Infusion Liquid Using Proximity Photodiode as a Sensor Based on ATmega328 (Arduino uno) microcontroller module, *Contemporary Engineering Sciences*, Vol. 13 No. 1: 315-321.
- [15] Maryani, Y. 2011. Calibration and Validation of Sensors as Co2 Gas Measuring Instruments Produced in the Photocatalysis Process of Active Detergent Compounds, *Journal of Chemical Engineering*. Vol. 7 No. 2:102-144.
- [16] Mirayanti, N. K. R., Gunawan, A. A. N., Sutapa, I. G. Ngurah, 2018, Humidity Monitoring System for Oyster Mushroom Cultivation Room by Web Based AVR Atmega328P-PU, *Advances in Applied Physics*, Vol. 6 No. 1: 9-13
- [17] Suarsana, K. B., Gunawan, A. A. N., Ratini, N., 2018, LPG Leakage Control Using SMS through SIM800L with MQ-2 Sensor and Stepper Motor Based on ATmega328 microcontroller module (Arduino uno), *Advances in Applied Physics*, Vol. 6 No. 1: 15-18.
- [18] Turang, D. A. O. 2015. Development of Control and Saving Relay Systems Mobile Based Lamp Usage. *SEMNASIVE Journal*. Vol. 1, No. 1:75-85.